

TEXAS DEPARTMENT OF LICENSING AND REGULATION ARCHITECTURAL
BARRIERS PROJECT REGISTRATION NUMBER
TABS2022009071

CLIFTON RIVERSIDE APARTMENTS

2406 EAST BELKNAP FORT WORTH, TEXAS

94 Apartments
HUD Project No. 113-35989

	SIGNATURE	DATE
OWNER		
ARCHITECT		
CONTRACTOR		
BONDING AGENT		
LENDER		

APPLICABLE CODES
2015 INTERNATIONAL BUILDING CODE
2015 INTERNATIONAL MECHANICAL CODE
2015 INTERNATIONAL PLUMBING CODE
2020 NATIONAL ELECTRICAL CODE
2015 INTERNATIONAL FIRE CODE
2015 INTERNATIONAL ENERGY CONSERVATION CODE
FAIR HOUSING ACT DESIGN MANUAL
2010 ADA STANDARDS for ACCESSIBLE DESIGN
2009 ICC A117.1 ACCESSIBLE & USABLE BUILDINGS and FACILITIES

DESIGN CONCEPTS & RENDERINGS

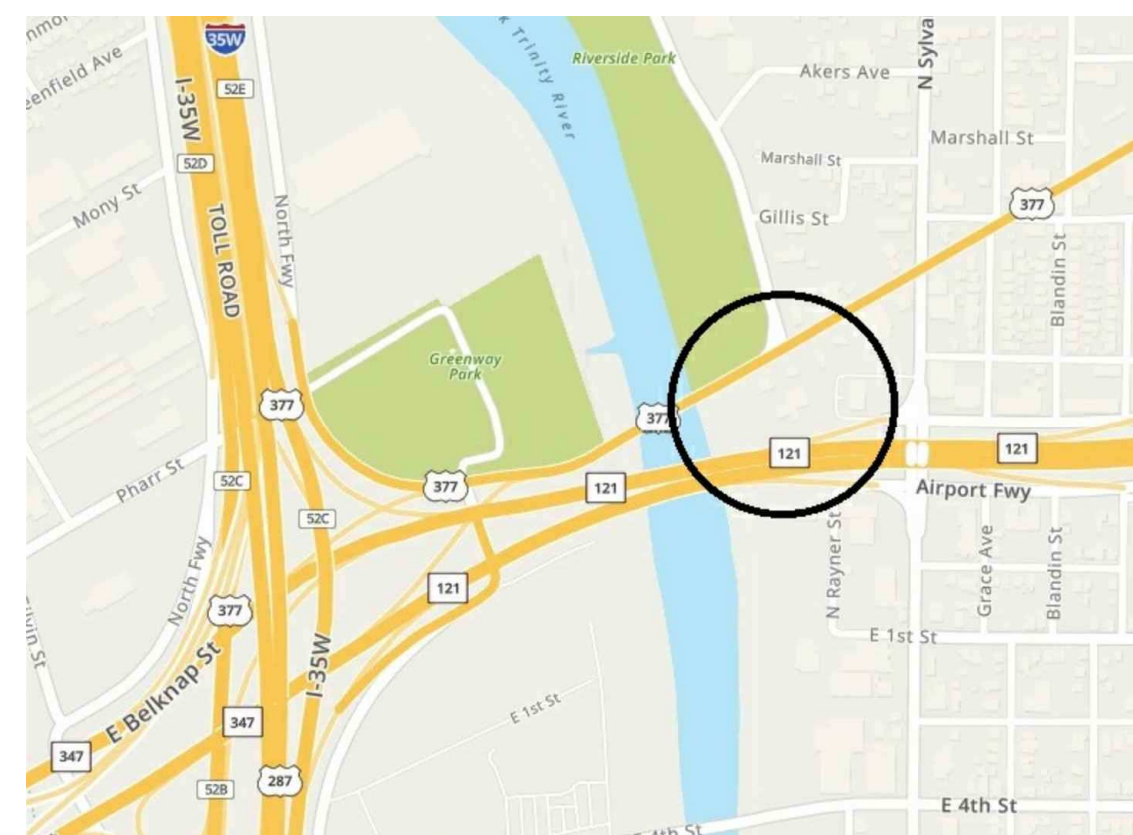
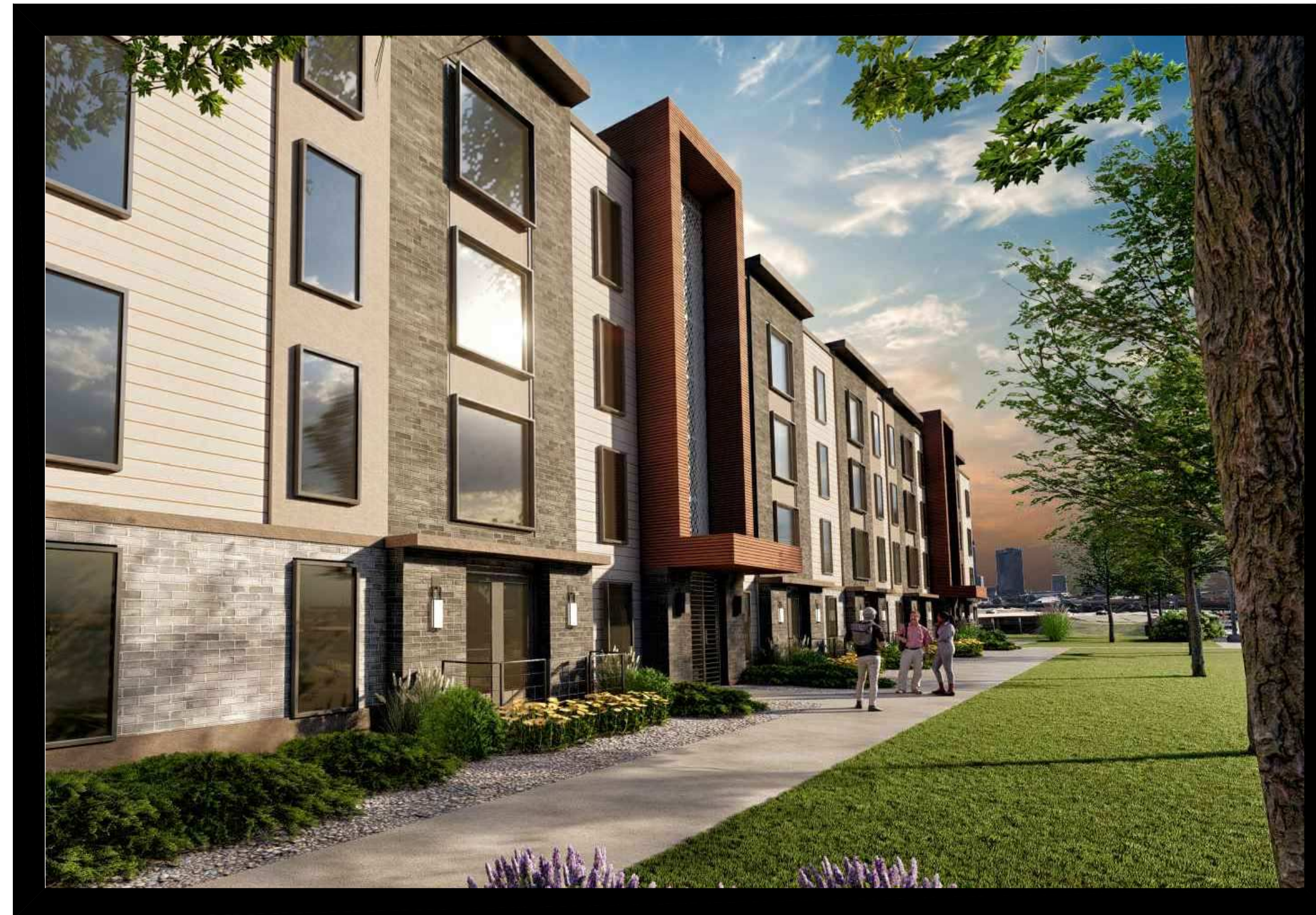

 VICINITY PLAN

**PERMIT SET
1-28-2022**

Owner/Developer

OVERLAND
PROPERTY GROUP

**OPG Clifton
Riverside Partners, LLC**
254 N SANTA FE AVE, STE A
Salina, KS 67401
PH 913.396.6310; FAX 913.396.6312
www.overlandpg.com

Architect

**Jones Gillam Renz
Architects, INC.**
730 N. Ninth St.
Salina, KS 67401
PH 785.827.0386
www.jgrarchitects.com

Contractor

ARCO
NATIONAL CONSTRUCTION

**ARCO
National Construction**
900 N Rock Hill Rd.
St. Louis, MO 63119
PH 314.963.0715 FAX 314.963.7114
www.arconational.com/

Civil Engineer

 **m|ma**

civil engineering surveying landscape architecture planning
tspels registration number: 1 - 2759
tspels registration/license number: 10088000

MMA Engineering
519 East Border
Arlington, TX 76010
PH 817.469.1671; FAX 817.274.8757
www.mmatexas.com

MEP Engineer

 **LST**

LST Consulting Engineers, PA
4809 Vue Du Lac Place, Suite 301
Manhattan, KS 66503
785.587.8042; FAX 785.587.8039
mail@LSTengineers.com

Structural Engineer

 **BDC**











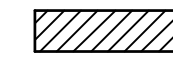

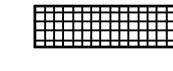
Bob D. Campbell & Co., Inc.
4338 Belleview
Kansas City, MO 64111
816.531.4144; FAX 816.531.8572
info@bdc-engrs.com

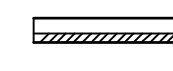
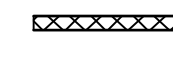
Interior Designer

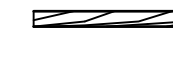
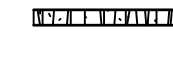
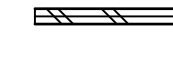
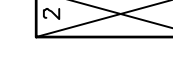

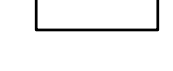
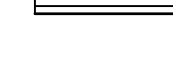
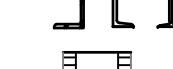



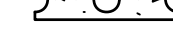

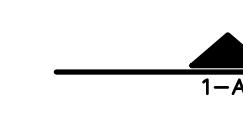
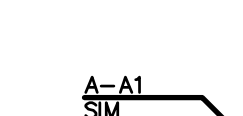

strut

Strut Interiors
Patricia Tram, RID
Dallas, TX
PH 214.629.1679
www.strut-interiors.com

MATERIAL LEGEND

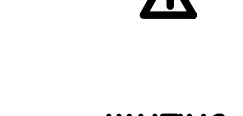
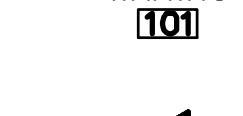
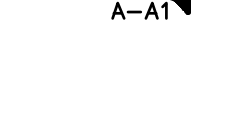
	BATT INSULATION
	BRICK MASONRY
	COMPACTED EARTH
	RIGID INSULATION
	POURED CONCRETE
	WALL W/ BRICK VENEER
	METAL STUD WALL
	CONCRETE WALL
	WOOD STUD WALL
	C.M.U. WALL
	PLYWOOD
	ROUGH WOOD
	FINISH WOOD
	METAL STUD
	GLASS LARGE SCALE
	STRUCTURAL STEEL
	CONC. MASONRY UNIT SECTION
	MTL JOIST
	MTL FURRING
	PRECAST CONC. SLAB

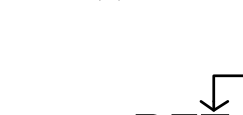
REFERENCE LEGEND

	DETAIL REFERENCE REF # - SHT. #
	DETAIL REFERENCE REF # - SHT #
	ELEVATION DESIGNATION
	DOOR MARK
	WINDOW MARK
	CUT LINE
	REVISIONS
	ROOM NAME & NUMBER
	PROJECTED VIEW OF PHOTOGRAPH REF # - SHT. #
	PROJECT NORTH
	TRUE NORTH
	DRAWING NAME
	DRAWING SCALE
	DRAWING REF #

ABBREVIATIONS

&	AND	Mas.	Masonry
∠	Angle	Max.	Maximum
⊕	At	M.C.	Medicine Cabinet
⊖	Centerline	Mech.	Mechanical
⊙	Diameter or Round	Memb.	Membrane
#	Pound or Number	Met.	Metal
Acous.	Acoustical	Mfr.	Manufacturer
Adj.	Adjustable	Mh.	Manhole
A.F.F.	Above Finished Floor	Min.	Minimum
Aggr.	Aggregate	Mir.	Mirror
Al.	Aluminum	Misc.	Miscellaneous
Apprx.	Approximate	M.O.	Masonry Opening
Arch.	Architect or Architectural	Mtd.	Mounted
Asb.	Asbestos	N.	North
Asph.	Asphalt	N.I.C.	Not in Contract
A.V.	Audio Visual	No. or #	Number
Bd.	Board	Nom.	Nominal
Bldg.	Building	N.T.S.	Not To Scale
Blk.	Block	O/	On or Over
Blkg.	Blocking	Obs.	Obscure
Bm.	Beam	O.C.	On Center
Bot.	Bottom	O.D.	Outside Diameter
BO	BY OWNER	Off.	Office
Brg.	Bearing	Opp.	Opposite
Brk.	Brick	P	Paint
Cab.	Cabinet	Pi.	Plate
Cig.	Ceiling	P.Lam.	Plastic Laminate
Cir.	Clear	Plas.	Plaster
Cntr.	Counter	Plywd.	Plywood
Col.	Column	Pr.	Pair
Conc.	Concrete	Pt.	Point
C.T.	Ceramic Tile	P.T.D.	Paper Towel Dispenser
CMU	Concrete Masonry Unit	Ptn.	Partition
Ctr.	Center	P.T.R.	Paper Towel Receptacle
Dbl.	Double	Q.T.	Quarry Tile
Det.	Detail	R	Riser
D.F.	Drinking Fountain	R.ad.	Radius
Dia.	Diameter	R.D.	Roof Drain
Dim.	Dimension	Ref.	Reference
Dn.	Down	Reinf.	Reinforced
Dr.	Door	Req'd	Required
Ds.	Downspout	Resil.	Resilient
Dwg.	Drawing	Rm.	Room
Dwr.	Drawer	R.O.	Rough Opening
(E)	Existing	S	South
Ext.	Exterior	S.B.	Splash Block
Exp.	Expansion	S.C.	Solid Core
Exp.	Expansion	Sched.	Schedule
Exp.	Expansion	S.D.	Soap Dispenser
Exp.	Expansion	Spec.	Specification
Ext.	Exterior	Spec.	Specification
F.A.	Fire Alarm	Sq.	Square
F.D.	Fire Alarm	Std.	Standard
Fdn.	Foundation	Stl.	Steel
F.E.	Fire Extinguisher	Str.	Structural
F.E.C.	F.E. Cabinet	Strg.	Storage
Fl.	Floor	Susp.	Suspended
Flash.	Flashing	Sym.	Symmetrical
Fl.	Flow line	Tex.	Texture
Ft.	Foot or feet	T.B.	Towel Bar
Ftg.	Footing	T.Bd.	Tack Board
Furr.	Furring	Temp.	Tempered
Fut.	Future	T.&G.	Tongue & Groove
Ga.	Gauge	Thk.	Thick
Galv.	Galvanized	T.O.M.	Top Of Masonry
G.B.	Grab Bar	T.O.S.	Top Of Steel
Gl.	Glass	T.P.	Top Of Pavement
Gnd.	Ground	T.P.D.	Toilet Paper Dispenser
Gr.	Grade	T.V.	Television
Gyp.	Gypsum	T.W.	Tackwall
H.B.	Hose Bibb	Typ.	Typical
H.C.	Hollow Core	Trd.	Tread
Hdwd.	Hardwood	U.O.N.	Unless Otherwise Noted
H.M.	Hollow Metal	Ur.	Urinal
Horiz.	Horizontal	V.C.T.	Vinyl Composition Tile
Hr.	Hour	V.T.	Vinyl Tile
Hgt.	Height	V.B.	Vapor Barrier
I.D.	Inside Diameter	Vert.	Vertical
Insul.	Insulation	Vest.	Vestibule
Int.	Interior	Vyl.	Vinyl
Jan	Janitor	W.	West
Jt.	Joint	w/	With
Kit.	Kitchen	w/o	Without
Lab.	Laboratory	w/c	Wall Covering
Lam.	Laminate	Wd.	Wood
Lav.	Lavatory	Wp.	Waterproof
Lkr.	Locker	Wdw.	Window
Lt.	Light	Wsc.	Wainscot
		Wt.	Weight

SHEET INDEX

GENERAL	STRUCTURAL
COVER	S1.0 GENERAL NOTES AND MAILING SCHEDULE
SHEET INDEX	S1.1 SCHEDULES
COMCHECK REPORTS	S1.2 SCHEDULES AND GENERAL DETAILS
HUD PROJECT DATA SHEET	S2.1 FOUNDATION PLAN
CP1 CODE FOOTPRINT	S2.2 SECOND FLOOR FRAMING PLAN
CP2 CODE FOOTPRINT	S2.3 THIRD FLOOR FRAMING PLAN
UFAS1 UNIFORM FEDERAL ACCESSIBILITY STANDARDS	S2.4 FOURTH FLOOR FRAMING PLAN
UFAS2 UNIFORM FEDERAL ACCESSIBILITY STANDARDS	S2.5 ROOF FRAMING PLAN
UFAS3 UNIFORM FEDERAL ACCESSIBILITY STANDARDS	S2.6 SHEARWALL PLAN
FH FAIR HOUSING DIAGRAMS	S3.1 SECTIONS
TAS1 TEXAS ACCESSIBILITY STANDARDS DIAGRAMS	S3.2 SECTIONS
TAS2 TEXAS ACCESSIBILITY STANDARDS DIAGRAMS	S3.3 SECTIONS
ADA 2010 ADA STANDARD FOR ACCESSIBLE DESIGN	S3.4 SECTIONS
	S3.5 SECTIONS
	S3.6 SECTIONS
CIVIL	MECHANICAL
C0.0 COVER SHEET	ME0.1 GENERAL NOTES
C0.1 FINAL PLAN	ME2.1 M/E ROOF PLAN
C1.0 GENERAL NOTES	M2.1 FIRST FLOOR HVAC PLAN
C2.0 DEMOLITION PLAN	M2.2 SECOND FLOOR HVAC PLAN
C3.0 SITE PLAN	M2.3 THIRD FLOOR HVAC PLAN
C4.0 DIMENSION CONTROL PLAN	M2.4 FOURTH FLOOR HVAC PLAN
C5.0 PAVING PLAN	M4.1 UNIT HVAC PLANS
C6.0 OVERALL GRADING PLAN	M4.2 UNIT HVAC PLANS
C6.1 GRADING PLAN	M4.3 ENLARGED COMMON HVAC PLANS
C6.2 GRADING PLAN	M6.1 SCHEDULES AND DETAIL
C6.3 GRADING PLAN	P2.1 FIRST FLOOR DRAIN & VENT PLAN
C6.4 GRADING PLAN	P2.2 SECOND FLOOR DRAIN & VENT PLAN
C7.0 EROSION CONTROL PLAN	P2.3 THIRD FLOOR DRAIN & VENT PLAN
C7.1 EROSION CONTROL DETAILS	P2.4 FOURTH FLOOR DRAIN & VENT PLAN
C8.1 PRE-DEV DRAINAGE AREA MAP	P2.5 FIRST FLOOR DOMESTIC WATER PLAN
C8.1 POST-DEV DRAINAGE AREA MAP	P2.6 SECOND FLOOR DOMESTIC WATER PLAN
C9.0 STORM SEWER PLAN	P2.7 THIRD FLOOR DOMESTIC WATER PLAN
C10.0 UTILITY PLAN	P2.8 FOURTH FLOOR DOMESTIC WATER PLAN
C11.0 PAVING DETAILS	P4.1 UNIT PLUMBING PLANS
C11.1 PAVING DETAILS	P4.2 UNIT PLUMBING PLANS
C11.2 PAVING DETAILS	P4.3 UNIT PLUMBING PLANS
C11.3 PAVING DETAILS	P6.1 SCHEDULE AND DETAILS
C11.4 PAVING DETAILS	
C11.5 WATER DETAILS	
C11.6 SEWER DETAILS	
LANDSCAPE	ELECTRICAL
L1.00 LANDSCAPE PLAN	E1.1 ELECTRICAL SITE PLAN
L1.01 LANDSCAPE DETAILS	E2.1 FIRST FLOOR ELECTRICAL PLAN
LF1.01 URBAN FORESTRY PART 2 PROPOSED PLAN	E2.2 SECOND FLOOR ELECTRICAL PLAN
	E2.3 THIRD FLOOR ELECTRICAL PLAN
	E2.4 FOURTH FLOOR ELECTRICAL PLAN
	E2.5 FIRST FLOOR SPECIAL SYSTEMS PLAN
	E2.6 SECOND FLOOR SPECIAL SYSTEMS PLAN
	E2.7 THIRD FLOOR SPECIAL SYSTEMS PLAN
	E2.8 FOURTH FLOOR SPECIAL SYSTEMS PLAN
	E4.1 UNIT ELECTRICAL PLANS
	E4.2 UNIT ELECTRICAL PLANS
	E4.3 UNIT ELECTRICAL PLANS
	E4.4 ENLARGED FIRST & FOURTH FLOOR ELECTRICAL PLANS
	E6.1 DETAILS
	E6.2 ELECTRICAL RISER DIAGRAMS
	E6.3 ELECTRICAL RISER DIAGRAM - HOUSE SERVICE
	E6.4 PANEL SCHEDULES
	E6.5 SCHEDULES AND EXTERIOR LIGHTING CONTROL DIAGRAM
ARCHITECTURAL	
A1.1 ENLARGED SITE PLAN	
A1.2 SITE DETAILS	
A2.0 GENERAL NOTES & PARTITION SCHEDULE	
A2.1 FIRST FLOOR PLAN	
A2.2 SECOND FLOOR PLAN	
A2.3 THIRD FLOOR PLAN	
A2.4 FOURTH FLOOR PLAN	
A2.5 ENLARGED PUBLIC SPACES	
A2.6 COURTYARD	
A2.7 UNIT GENERAL NOTES & PARTITION SCHEDULE	
A2.8 CASEWORK DETAILS	
A2.9 1-BED 1-BATH ADPT. UNITS DETAILS	
A2.10 1-BED 1-BATH ADPT. UNITS DETAILS	
A2.11 2-BED 2-BATH ADPT. UNITS DETAILS	
A2.12 2-BED 2-BATH ADPT. UNITS DETAILS	
A2.13 3-BED 2-BATH ADPT. UNITS DETAILS	
A2.14 3-BED 2-BATH ADPT. UNITS DETAILS	
A2.15 1-BED 1-BATH ACCESSIBLE UNIT DETAILS	
A2.16 2-BED 2-BATH ACCESSIBLE UNIT DETAILS	
A2.17 3-BED 2-BATH ACCESSIBLE UNIT DETAILS	
A3.1 EXTERIOR ELEVATIONS	
A3.2 EXTERIOR ELEVATIONS	
A3.3 EXTERIOR ELEVATIONS	
A3.4 BUILDING SECTION	
A3.5 BUILDING SECTION	
A4.1 WALL SECTIONS	
A4.2 WALL SECTIONS	
A4.3 WALL SECTIONS	
A4.4 WALL SECTIONS	
A4.5 WALL SECTIONS	
A4.6 WALL SECTIONS	
A4.7 WALL SECTIONS	
A4.8 WALL SECTIONS	
A4.9 WALL SECTIONS	
A4.10 DETAILS	
A4.11 FIRE PENETRATIONS	
A5.1 ROOF PLAN	
A5.2 DETAILS	
A6.1 ENLARGED STAIR S1, S2, S3 PLANS	
A6.2 STAIR SECTIONS	
A6.3 STAIR/ELEVATOR DETAILS	
A6.4 ENLARGED ELEVATOR PLAN AND ELEVATOR SECTIONS	
A6.5 CULTURED STONE INSTALLATION DETAILS	
A6.6 HARDIE LAP SIDING INSTALLATION DETAILS	
A6.7 HARDIE REVEAL PANEL SIDING INSTALLATION DETAILS	
A6.8 NICHHA SIDING INSTALLATION DETAILS	
A6.9 LAMINATORS INC. PANEL INSTALLATION DETAILS	
A7.1 FIRST FLOOR REFLECTED CEILING PLANS	
A7.2 SECOND FLOOR REFLECTED CEILING PLANS	
A7.3 THIRD FLOOR REFLECTED CEILING PLANS	
A7.4 FOURTH FLOOR REFLECTED CEILING PLANS	
A8.1 ENLARGED RESTROOM PLAN AND INTERIOR ELEVATIONS	
A8.2 CASEWORK ELEVATION AND SECTIONS	
A8.1 FIRST FLOOR, FLOOR FINISH PLAN	
A8.2 SECOND FLOOR, FLOOR FINISH PLAN	
A8.3 THIRD FLOOR, FLOOR FINISH PLAN	
A8.4 FOURTH FLOOR, FLOOR FINISH PLAN	
A9.5 INTERIOR ELEVATIONS	
A9.6 INTERIOR ELEVATIONS	
A9.7 INTERIOR ELEVATIONS	
A9.8 INTERIOR ELEVATIONS	
A9.9 INTERIOR ELEVATIONS	
A10.1 FINISH AND DOOR SCHEDULES	
A10.2 DOOR SECTIONS	
A10.3 WINDOW SCHEDULE AND SECTIONS	
ID 0.00 INTERIOR DESIGN SCHEDULES	
ID 0.01 INTERIOR DESIGN SCHEDULES	
ID 0.02 INTERIOR DESIGN SCHEDULES	
ID 0.03 INTERIOR DESIGN SCHEDULES	

PROJECT DATA SHEET

Project Name:

Clifton Riverside

94 UNITS

Location:

2406 E Belknap, Fort Worth, TX

LIVING AREA UNIT (S.F.) CALCULATIONS								
UNIT TYPE	UNIT MIX DESCRIPTION	NET AREA		BALCONY / PATIOS	BALCONY STORAGE	DIRECT ACCESS GARAGES	GROSS AREA	
		HUD (1)	MARKET (3)				HUD (2)	MARKET (4)
1A-HC	1BD/1BA	613	663	0	0	0	663	663
1B-AV	1BD/1BA	613	663	0	0	0	663	663
1C	1BD/1BA	613	663	0	0	0	663	663
1D	1BD/1BA	695	744	0	0	0	744	744
1E	1BD/1BA	692	752	0	0	0	752	752
2A-HC	2BD/2BA	806	865	0	0	0	865	865
2B-AV	2BD/2BA	806	865	0	0	0	865	865
2C	2BD/2BA	806	865	0	0	0	865	865
2D	2BD/2BA	927	993	0	0	0	993	993
3A-HC	3BD/2BA	998	1067	0	0	0	1,067	1,067
3B	3BD/2BA	998	1067	0	0	0	1,067	1,067
3C	3BD/2BA	992	1066	0	0	0	1,066	1,066

NO. OF UNITS	APT MIX	TOTAL LIVING AREA (S.F.) CALCULATIONS						TOTAL GROSS	
		TOTAL NET		BALCONY / PATIOS	BALCONY STORAGE	DIRECT ACCESS GARAGES	HUD (2)	MARKET (4)	
		HUD (1)	MARKET (3)						
2	2.13%	1,226	1,326	0	0	0	1,326	1,326	
1	1.06%	613	663	0	0	0	663	663	
17	18.09%	10,421	11,271	0	0	0	11,271	11,271	
4	4.26%	2,780	2,976	0	0	0	2,976	2,976	
4	4.26%	2,768	3,008	0	0	0	3,008	3,008	
2	2.13%	1,612	1,730	0	0	0	1,730	1,730	
1	1.06%	806	865	0	0	0	865	865	
39	41.49%	31,434	33,735	0	0	0	33,735	33,735	
4	4.26%	3,708	3,972	0	0	0	3,972	3,972	
1	1.06%	998	1,067	0	0	0	1,067	1,067	
7	7.45%	6,986	7,469	0	0	0	7,469	7,469	
12	12.77%	11,904	12,792	0	0	0	12,792	12,792	
TOTALS:	94	75,256	80,874	0	0	0	80,874	80,874	

BUILDING ANALYSIS												
UNIT TYPE	BUILDINGS LEVEL	Level 1	Level 2	Level 3	Level 4	Level 6	Level 7	Level 8	Level 9	Level 10	Level 11	NUMBER OF UNITS
		QUANTITY PER BUILDING LEVEL										
1A-HC	1BD/1BA	0	1	0	1	0	0	0	0	0	0	2
1B-AV	1BD/1BA	0	0	1	0	0	0	0	0	0	0	1
1C	1BD/1BA	4	5	5	3	0	0	0	0	0	0	17
1D	1BD/1BA	1	1	1	1	0	0	0	0	0	0	4
1E	1BD/1BA	1	1	1	1	0	0	0	0	0	0	4
2A-HC	2BD/2BA	1	1	0	0	0	0	0	0	0	0	2
2B-AV	2BD/2BA	0	0	1	0	0	0	0	0	0	0	1
2C	2BD/2BA	9	10	10	10	0	0	0	0	0	0	39
2D	2BD/2BA	1	1	1	1	0	0	0	0	0	0	4
3A-HC	3BD/2BA	1	0	0	0	0	0	0	0	0	0	1
3B	3BD/2BA	1	2	2	2	0	0	0	0	0	0	7
3C	3BD/2BA	3	3	3	3	0	0	0	0	0	0	12
TOTAL UNITS		22	25	25	22	0	0	0	0	0	0	94
BUILDINGS LEVEL		Level 1	Level 2	Level 3	Level 4	Level 6	Level 7	Level 8	Level 9	Level 10	Level 11	TOTAL
QUANTITY PER BUILDING LEVEL		1	1	1	1	0	0	0	0	0	0	1
HUD GROSS SF TOTALS @ BUILDING		19,123	21,314	21,314	19,123	0	0	0	0	0	0	
HUD GROSS SF TOTALS FOR BUILDINGS		19,123	21,314	21,314	19,123	0	0	0	0	0	0	80,874

OTHER	NUMBER	S.F./each	TOTAL
CLUBHOUSE/LEASING OFFICE (LVL 1)	1	2,458	2,458
COMMUNITY/FITNESS ROOM (LVL 4)	1	1,613	1,613
SUBTOTALS			84,945
OTHER BUILDINGS or SPACES	NUMBER	S.F./each	TOTAL
STAIRS/BREEZEWAYS (LVL 1)	1	3,743	3,743
STAIRS/BREEZEWAYS (LVL 2)	1	4,186	4,186
STAIRS/BREEZEWAYS (LVL 3)	1	4,186	4,186
STAIRS/BREEZEWAYS (LVL 4)	1	4,751	4,751
ELEVATOR (LVL 1)	1	84	84
ELEVATOR (LVL 2)	1	84	84
ELEVATOR (LVL 3)	1	84	84
ELEVATOR (LVL 4)	1	84	84
JANITOR/TRASH (LVL 1)	1	153	153
JANITOR/TRASH (LVL 2)	1	156	156
JANITOR/TRASH (LVL 3)	1	156	156
JANITOR/TRASH (LVL 4)	1	138	138
ELECTRICAL/MECHANICAL (LVL 1)	1	314	314
ELECTRICAL/MECHANICAL (LVL 2)	1	186	186
ELECTRICAL/MECHANICAL (LVL 3)	1	186	186
ELECTRICAL/MECHANICAL (LVL 4)	1	186	186
TOTAL AREA OF BUILDINGS			103,622

EXTERIOR FINISH MATERIALS					
	Ground	Level 2-7	Level 8-10	Level 11	
Percent of Brick	95%	12%	0%	0%	
Percent of Stucco	0%	0%	0%	0%	
Percent of Hardi Plank	5%	88%	0%	0%	
Masonry Brick/Stucco/ Hardi					100%

NOTE: Indicate percentages of each siding material used

SITE ANALYSIS	
ACTUAL:	
NET LAND AREA:	3
TOTAL APTS:	94 Units
ACTUAL DENSITY:	31.9837Units per Acre
REQUIRED:	
ZONING	MU-2
ELEVATORS:	1 elevator

PARKING ANALYSIS (Please see NOTES for HC Parking Requirements)					
REQUIRED PARKING:	147				
ACTUAL SPACES:	STANDARD	COMPACT	ACCESSIBLE	VISITOR	TOTAL
SURFACE PARKING	124	0	11	12	147
TOTAL	124	0	11	12	147

EXTERIOR SPACES	NUMBER	S.F./each	TOTAL
Courtyard/Patio	1	5,267	5,267
TOTAL AREA OF EXTERIOR SPACES			5,267

HUD S.F. ANALYSIS TOTALS	
NET LIVING AREA :	75,256
GROSS LIVING AREA:	80,874
GROSS AREA plus Leasing Office & Community Area	84,945
GROSS AREA plus Amenities, and Bldg. Area	103,622

HUD/Market Apartment Unit Definitions
Net & Gross SF Area Calculations
Apartments ONLY

(1) HUD NET AREA: Defined as "Paint-to-Paint". It is the living area of a unit measured to the inside face of perimeter drywall.

(2) HUD GROSS AREA: Defined by adding thickness (width) of unit perimeter stud walls, includes thickness of corridor walls and includes the area measured to the centerline of any party wall. HUD gross sf also includes the area of a direct access garage and balcony storage if provided for the unit

HUD GROSS FLOOR AREA (ref HUD 2264) (See Note 5)	
GROSS LIVING AREA:	80,874
CLUBHOUSE/COMMUNITY/LEASING	4,071
STAIRS/BREEZEWAYS	16,866
MAINT./JANITOR/TRASH	1,475

(5) HUD GROSS FLOOR AREA: The sum of the areas of headroom height within the exterior walls, measured to the exterior faces of the walls or to the center line of walls separating attached buildings.
NOTE: Built-in garages, commercial area, basement and all other areas within the exterior walls are to be included.
Items excluded: recessed, extended or continuous balconies, attached or detached carports accessory buildings, patios, porches, or terraces and all other areas outside the exterior walls

BUILDING CODE INFORMATION

OCCUPANCY OVERALL: R-2 W/ MIXED

OCCUPANCY GROUPS: B OFFICE
R-2 APARTMENTS

CONSTRUCTION TYPE: V-A

AREA ALLOWED SM /FLB: B 54,000 SF
R-2 36,000 SF

AREA INCREASE 75% ADD: R-2 45,000 SF
(NON-SEPARATED USES. PER IBC SEC. 302.3.2)

ALLOWABLE TOTAL BLDG AREA(4x45,000) 180,000 SF

ACTUAL BUILDING AREA:

FIRST FLOOR	R-2	26,658 SF
SECOND FLOOR	R-2	26,825 SF
THIRD FLOOR	R-2	26,758 SF
FOURTH FLOOR	R-2	26,540 SF
TOTAL BUILDING AREA	R-2	106,781 SF

ALLOWABLE STORIES R-2 S: 4

ALLOWABLE HEIGHT R-2 S: 60'

ACTUAL STORIES: 4

ACTUAL HEIGHT: 45'

TOTAL OCCUPANT LOAD:

FIRST FLOOR	210
SECOND FLOOR	107
THIRD FLOOR	107
FOURTH FLOOR	94
TOTAL	518

OCCUPANT LOAD FACTORS:

OCCUPANCY	USE	LOAD FACTOR	MAX. OCC=1 EXIT
B	LOBBY/COMMONS	15 sf/OCCUPANT	49
B	OFFICE	100 sf/OCCUPANT	49
B	MECH/ELEC	300 sf/OCCUPANT	49
R-2	APARTMENTS	200 sf/OCCUPANT	10

FIRE RESISTANCE RATING FOR BUILDING ELEMENTS: V-A

EXTERIOR BEARING WALLS: 1 HOUR (INTERIOR RATING ONLY, IBC SEC. 705.5, FS>10')

STRUCTURAL FRAME: 1 HOUR

INTERIOR BEARING WALLS: 1 HOUR

INTERIOR NON-BEARING WALLS: 0 HOUR

SHAFT ENCLOSURES: 2 HOUR

FLOOR/CEILING ASSEMBLY: 1 HOUR

CEILING/ROOF ASSEMBLY: 1 HOUR

CORRIDOR/DWELLING UNITS: .5 HOUR (INTERIOR RATING ONLY, IBC SEC. 1020.1)

OCCUPANCY SEPARATIONS: (NON-SEPARATED USES. PER IBC SEC. 302.3.2)

ALLOWABLE AREA & HEIGHT CALCULATIONS ARE BASED ON THE MOST RESTRICTIVE USE. DIFFERENT USES ARE NOT SEPARATED BY FIRE BARRIERS.

R2 TO R2 SEPARATION OF DWELLING UNITS = 1HR, 45 MIN. OPNGS

ROOF COVERINGS

CLASS B OR BETTER, TABL 1505.1

INCIDENTAL SEPARATIONS: (PER IBC TABLE 508.2.5)

STORAGE ROOMS OVER 100 SF - SPRINKLER SYSTEM (SMOKE BARRIER)

DWELLING UNITS - 1 HR FIRE PARTITIONS

SPECIAL CONDITIONS:

EXIT & EMERGENCY LIGHTING, PORTABLE FIRE EXTINGUISHERS, MANUAL FIRE ALARM

EGRESS - NO STEPS EXISTING OR PROPOSED AT REQUIRED EXITS

NON-RATED STAIR ENCLOSURES, 1019.3, EXCEP 4

FIRE ALARM REQUIREMENTS:

REQUIRED, PROVIDED - MANUAL FIRE ALARM SYSTEM, 907.2.9.1 & NFPA 72

SIGNALING SYSTEM IS AUDIBLE/VISUAL PER NFPA 72 & ADA INSTALLED THROUGHOUT

INITIATING DEVICES: PULL STATIONS; SMOKE DETECTION @ SLEEPING & COMMON AREAS, AUTOMATIC SPRINKLER SYSTEM FLOW AND TAMPER SWITCHES MONITORED.

SMOKE ALARM REQUIREMENTS:

REQUIRED, PROVIDED - SLEEPING ROOMS & AT EACH FLOOR

AUTOMATIC FIRE SUPPRESSION SYSTEM:

REQUIRED, PROVIDED PER NFPA 13

EMERGENCY POWER SOURCE:

EXIT SIGNS, EXIT ILLUMINATION & EMERGENCY LIGHTING IS BY BATTERY BACK-UP

HAZARDOUS MATERIALS: (PER IBC TABLE 307.1(1))

NO HAZARDOUS MATERIALS ARE TO BE STORED

STANDPIPES:

NOT REQUIRED PER 905.3.1(1) HEIGHT EXCEPTION

SMOKE CONTROL: NOT REQUIRED

SMOKE PARTITIONS: NOT REQUIRED

ASSEMBLY

SIGNS TO BE MOUNTED IN ASSEMBLY AREAS OF MAXIMUM OCCUPANT LOAD

EXITING: REFERENCE PLAN

LEGEND

DESIGNATED EMERGENCY EXIT

68°/24.4° ← EXIT WIDTH (ACTUAL/REQUIRED)
122/340 ← OCCUPANT LOAD (ACTUAL/ALLOWED)

1 HOUR CONSTRUCTION (LD BRG WALLS)

1/2 HOUR FIRE PARTITION, CORRIDOR
W/ 20 MIN OPENINGS (PER IBC TABLE 1016.5)
(INTERIOR RATING IBC TABLE 1020.1)

1 HOUR FIRE PARTITION; BETWEEN DWELLING, SLEEPING UNITS
W/ 45 MIN OPENINGS (PER IBC 709.3 & 715.4)

2 HOUR CONSTRUCTION; EXIT ENCLOSURE, SHAFT WALLS,
W/ 90 MIN OPENINGS (PER IBC TABLE 716.5)

EXIT LIGHT

EMERGENCY LIGHT

EXIT/EMERGENCY LIGHT

FIRE EXTINGUISHER

FIRE HYDRANT

FIRE ALARM REMOTE ANNUNCIATOR PANEL

FIRE ALARM CONTROL PANEL

EXAMPLE:

ASSEMBLY HALL	15
ROOM SQUARE FOOT/OCCUPANT LOAD FACTOR	5,550
OCCUPANT LOAD/REQUIRED NUMBER OF EXITS	370

PROJECT INFORMATION

TYPE OF CONSTRUCTION: NEW APARTMENT COMPLEX

FACILITY NAME: CLIFTON RIVERSIDE APARTMENTS

FACILITY ADDRESS: 2406 EAST BELKNAP
FORT WORTH, TX

OWNER NAME: OPG CLIFTON RIVERSIDE PARTNERS, LLC

OWNER ADDRESS: 254 N SANTA FE AVE, STE A
SALINA, KS 67401
ph: 913-396-6310
fax: 913-396-6312

REASON FOR SUBMITTAL: NEW CONSTRUCTION

COUNTY: TARRANT

FIRE DEPARTMENT: FORT WORTH

WATER SUPPLY: FORT WORTH

BUILDING INSPECTION DEPT: FORT WORTH

AUTHORITY HAVING JURISDICTION: FORT WORTH

ARCHITECT: JONES GILLAM RENZ ARCHITECTS, INC.
730 N. NINTH ST.
SALINA, KS 67401
ph: 785-827-0386
fax: 785-827-0392

CODES/REGULATIONS:

- 2015 INTERNATIONAL BUILDING CODE
- 2015 INTERNATIONAL MECHANICAL CODE
- 2015 INTERNATIONAL PLUMBING CODE
- 2020 NATIONAL ELECTRICAL CODE
- 2015 INTERNATIONAL FIRE CODE
- 2015 INTERNATIONAL ENERGY CONSERVATION CODE
- FAIR HOUSING ACT DESIGN MANUAL
- 2010 ADA STANDARDS for ACCESSIBLE DESIGN
- 2009 ICC A17.1 ACCESSIBLE & USABLE BUILDINGS and FACILITIES

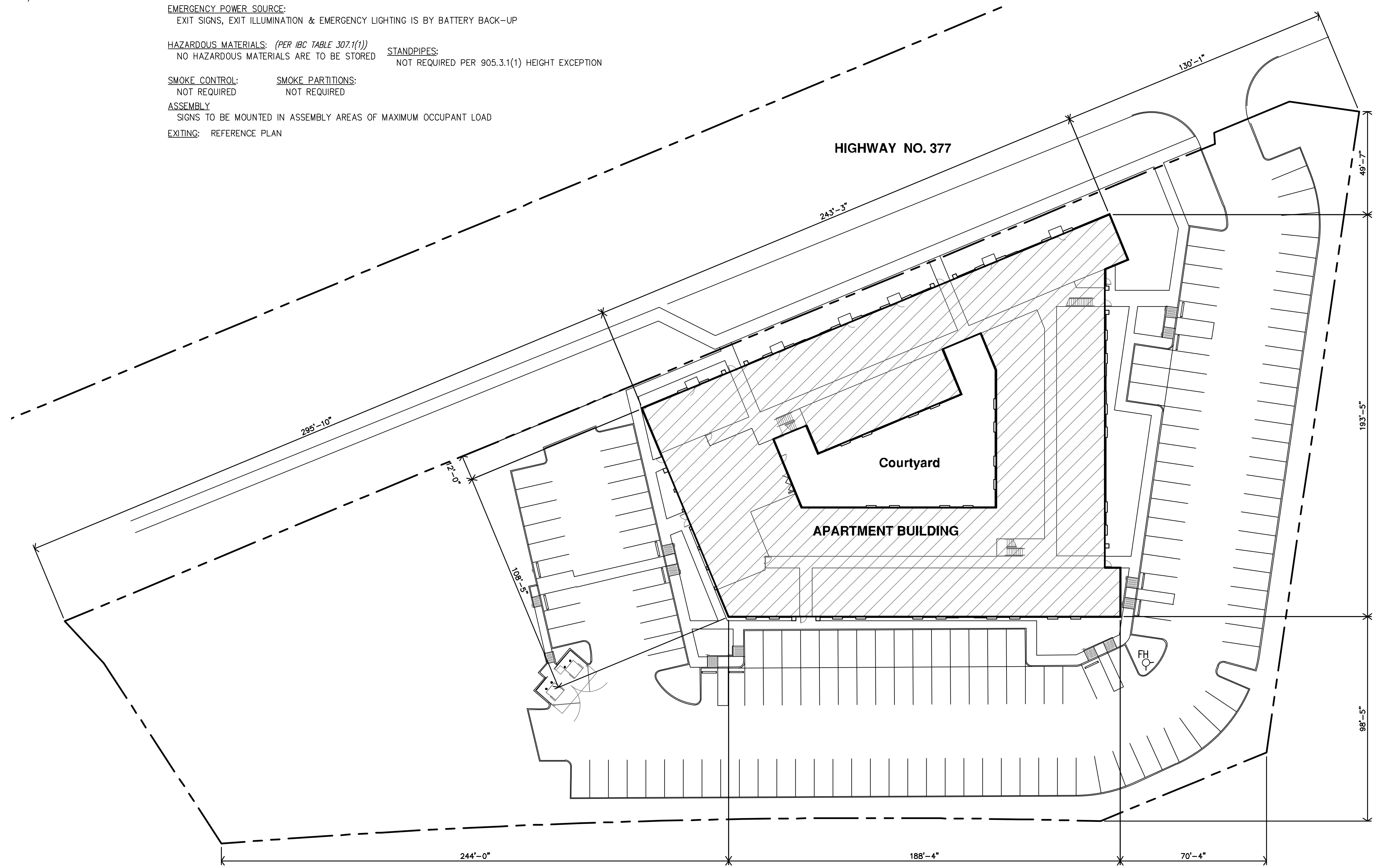

A SITE PLAN

0 30' 60' 120'

CLIFTON RIVERSIDE APARTMENTS
NEW APARTMENTS
FORT WORTH, TEXAS

Architects Planners Designers
 730 N. Ninth St., Suite 301
 P.O. Box 9398
 Salina, KS 67402
 jgr@jgarchitects.com
 785.827.0386

JONES GILLAM RENZ

REGISTERED ARCHITECT
 STATE OF TEXAS
 1-18-2015
 22415

REVISION:
 DATE: 1-28-2022
 JOB: 21-3137
 SHEET:

CFP1 COPYRIGHTED ©

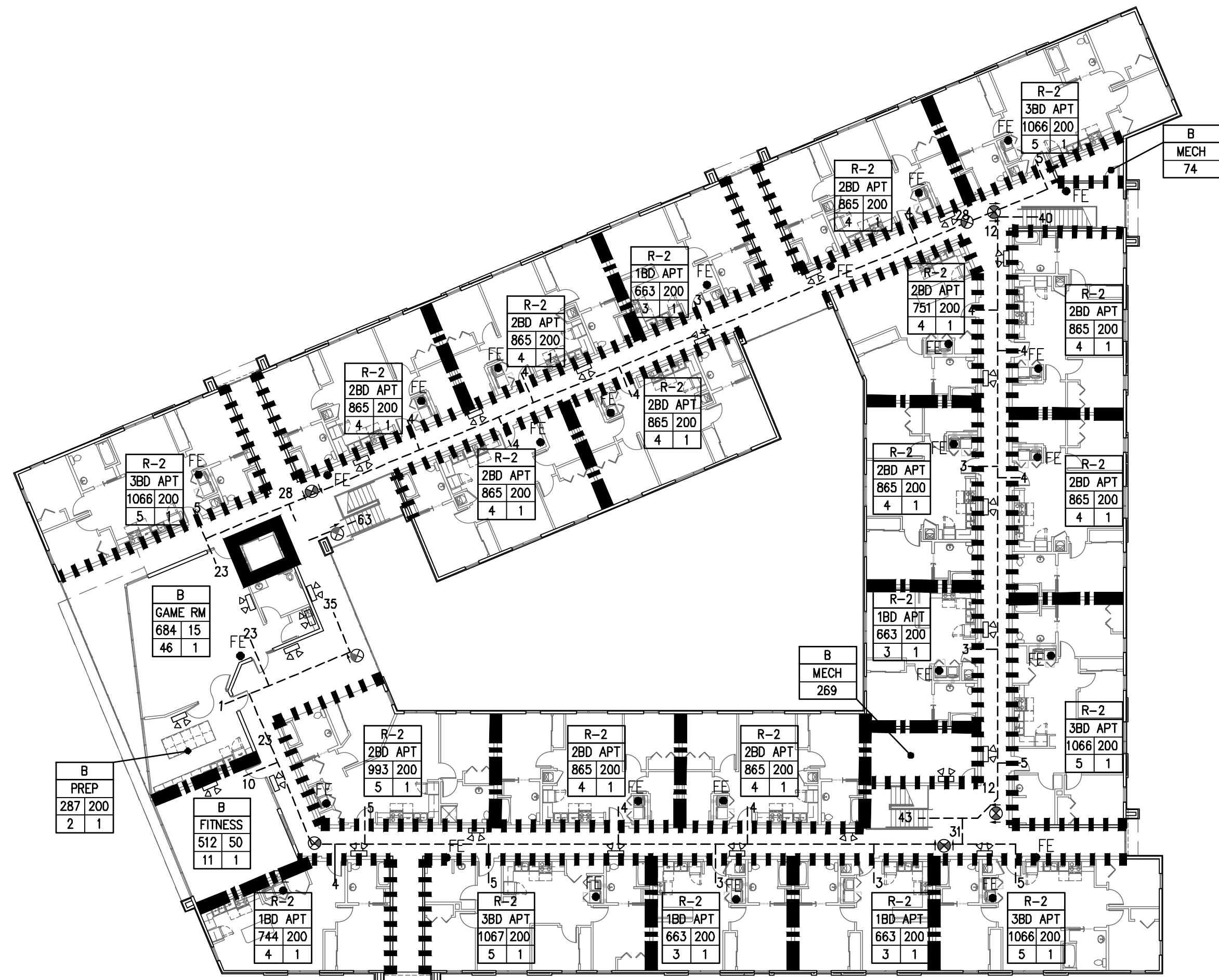

D FOURTH FLOOR PLAN
1"=20'-0"

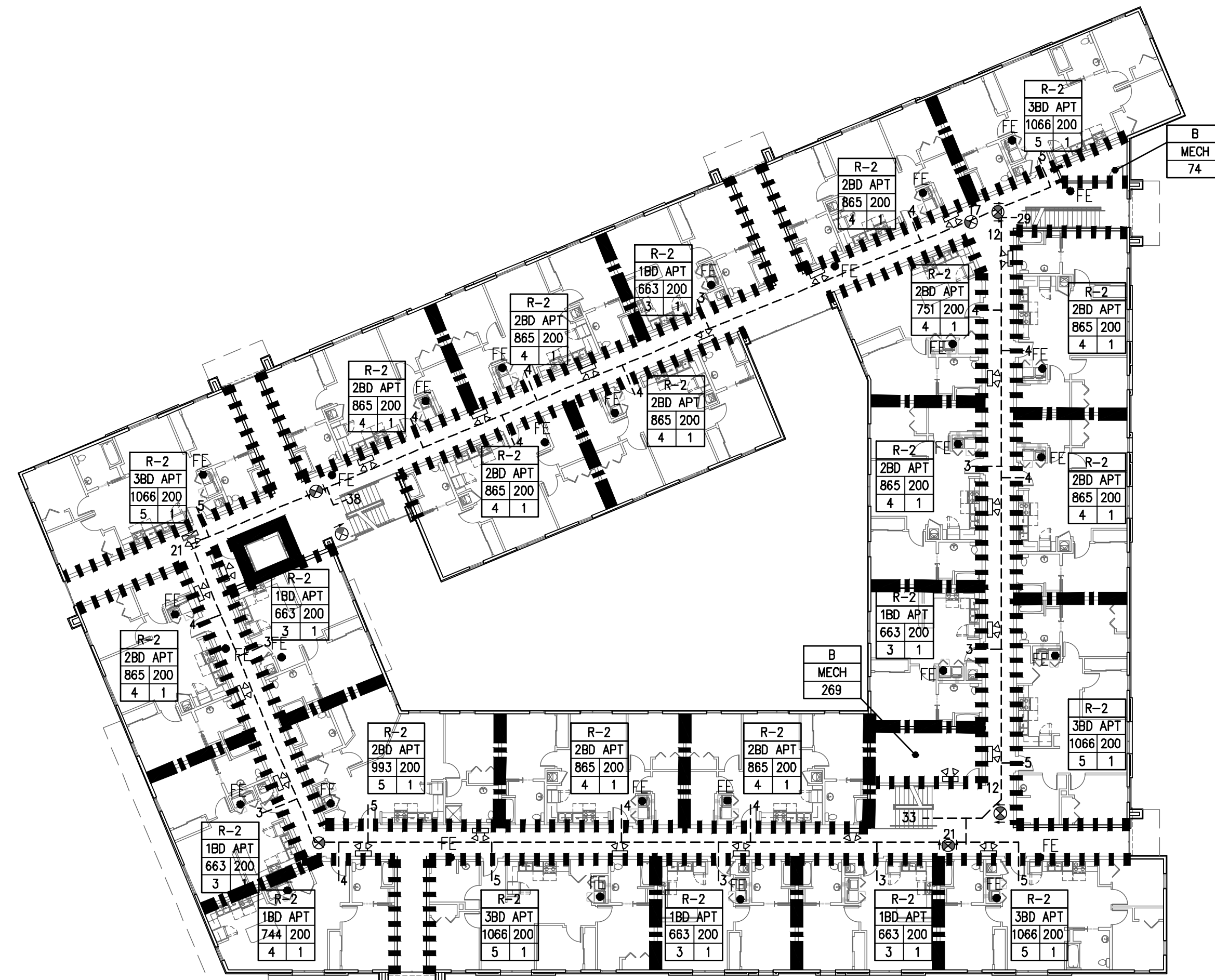

B SECOND FLOOR PLAN
1"=20'-0"

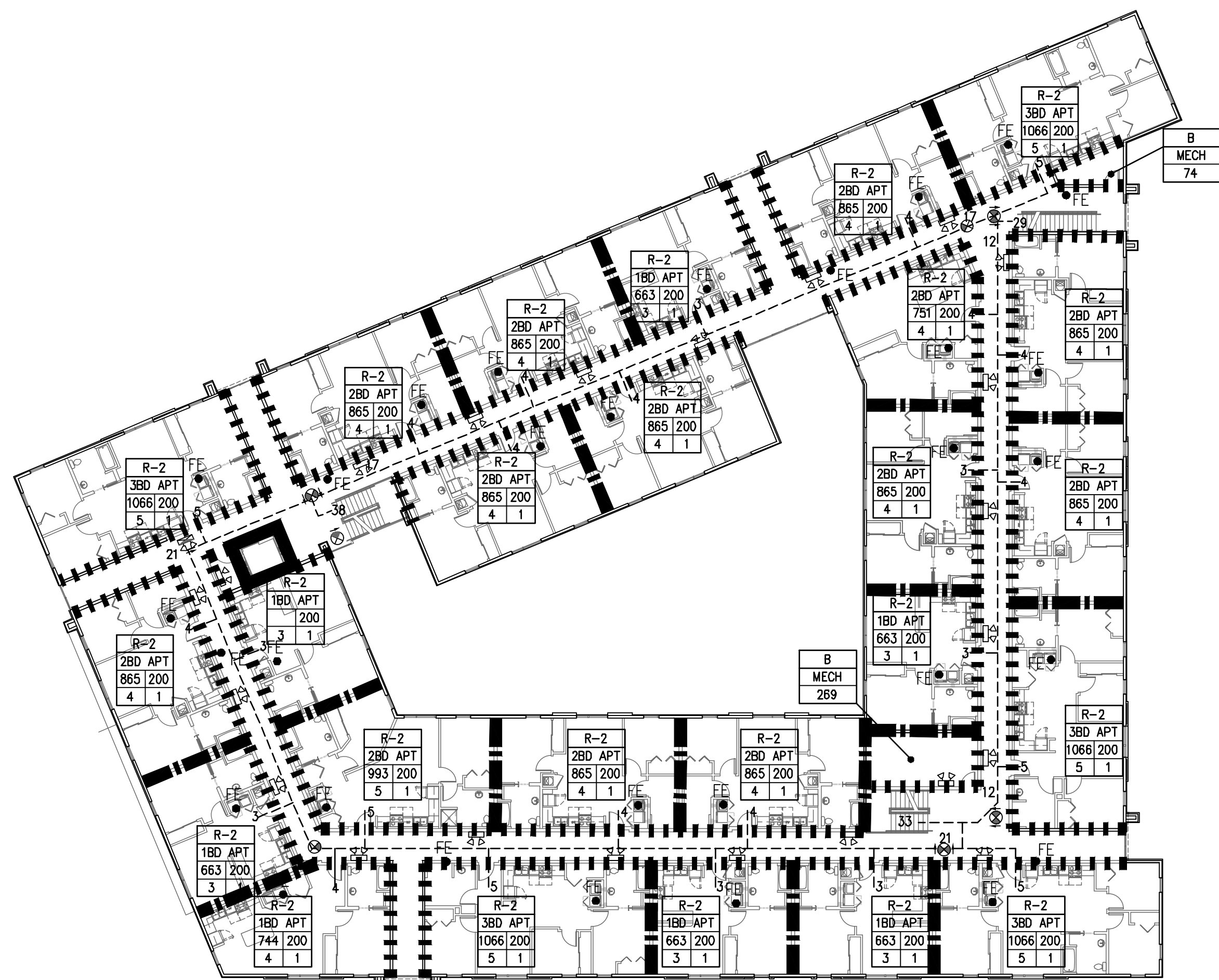

C THIRD FLOOR PLAN
1"=20'-0"

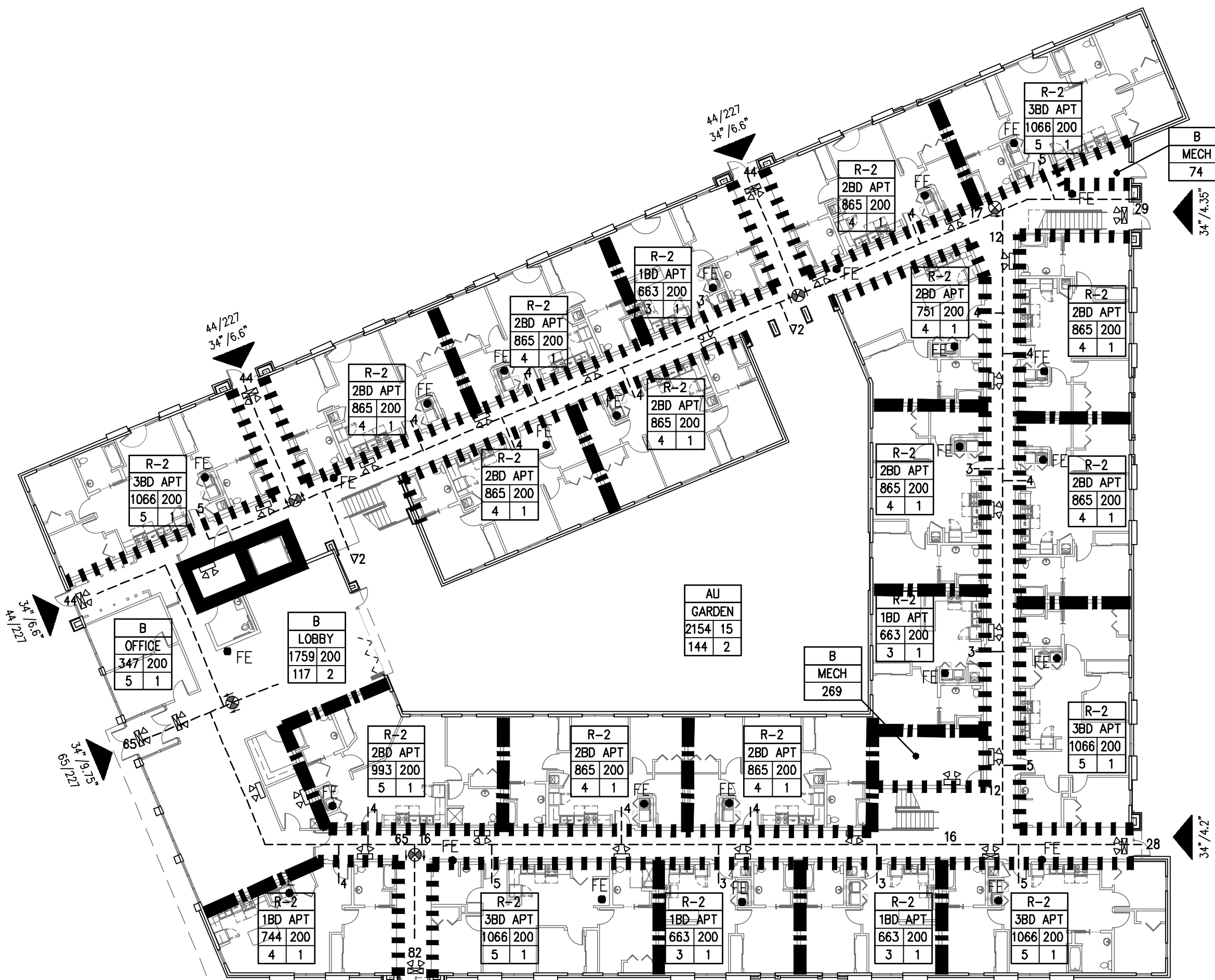

A FIRST FLOOR PLAN
1"=20'-0"

PROJECT INFORMATION

TYPE OF CONSTRUCTION NEW APARTMENT COMPLEX
 FACILITY NAME CLIFTON RIVERSIDE APARTMENTS
 FACILITY ADDRESS 2406 EAST BELKNAP FORT WORTH, TX
 OWNER NAME OPC CLIFTON RIVERSIDE PARTNERS, LLC
 OWNER ADDRESS 254 N SANTA FE AVE, STE A SALINA, KS 67401
 ph: 913-396-6310
 fax: 913-396-6312
 REASON FOR SUBMITTAL NEW CONSTRUCTION
 COUNTY TARRANT
 FIRE DEPARTMENT FORT WORTH
 WATER SUPPLY FORT WORTH
 BUILDING INSPECTION DEPT FORT WORTH
 AUTHORITY HAVING JURISDICTION FORT WORTH
 ARCHITECT JONES GILLAM RENZ ARCHITECTS, INC.
 730 N. NINTH ST.
 SALINA, KS 67401
 ph: 785-827-0386
 fax: 785-827-0392
 CODES/REGULATIONS 2015 INTERNATIONAL BUILDING CODE
 2015 INTERNATIONAL MECHANICAL CODE
 2015 INTERNATIONAL PLUMBING CODE
 2020 NATIONAL ELECTRICAL CODE
 2015 INTERNATIONAL FIRE CODE
 2015 INTERNATIONAL ENERGY CONSERVATION CODE
 FAIR HOUSING ACT DESIGN MANUAL
 2010 ADA STANDARDS for ACCESSIBLE DESIGN
 2009 ICC A117.1 ACCESSIBLE & USABLE BUILDINGS and FACILITIES

LEGEND

DESIGNATED EMERGENCY EXIT 68"/24.4" ← EXIT WIDTH (ACTUAL/REQUIRED)
 122/340 ← OCCUPANT LOAD (ACTUAL/ALLOWED)

1 HOUR CONSTRUCTION (LD BRG WALLS)
 1/2 HOUR FIRE PARTITION; CORRIDOR
 W/ 20 MIN OPENINGS (PER IBC TABLE 1016.5)
 (INTERIOR RATING IBC TABLE 1020.1)

1 HOUR FIRE PARTITION; BETWEEN DWELLING, SLEEPING UNITS
 W/ 45 MIN OPENINGS (PER IBC 709.3 & 715.4)

2 HOUR CONSTRUCTION; EXIT ENCLOSURE, SHAFT WALLS,
 W/ 90 MIN OPENINGS (PER IBC TABLE 716.5)

EXIT LIGHT
 EMERGENCY LIGHT
 EXIT/EMERGENCY LIGHT
 FIRE EXTINGUISHER
 FIRE HYDRANT
 FIRE ALARM REMOTE ANNUCIATOR PANEL
 FIRE ALARM CONTROL PANEL

EXAMPLE:
 OCCUPANCY GROUP (AU = ACCESSORY USE) ----- A-1
 OCCUPANCY USE ----- ASSEMBLY HALL
 ROOM SQUARE FOOT/OCCUPANT LOAD FACTOR ----- 5,550 15
 OCCUPANT LOAD/REQUIRED NUMBER OF EXITS ----- 370 2

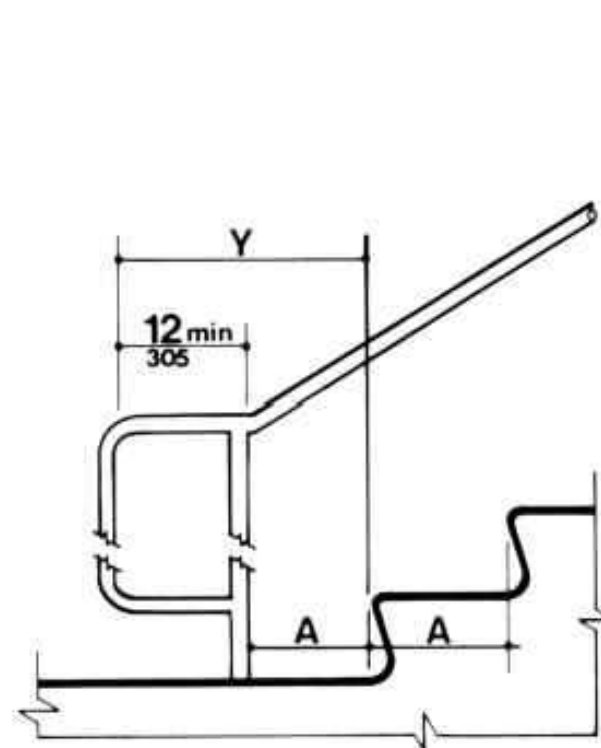

Figure 19(c)
Stair Handrails - Extension at Bottom of Run

Note: X is the 12 in minimum handrail extension required at each top riser. Y is the minimum handrail extension of 12 in plus the width of one tread that is required at each bottom riser.

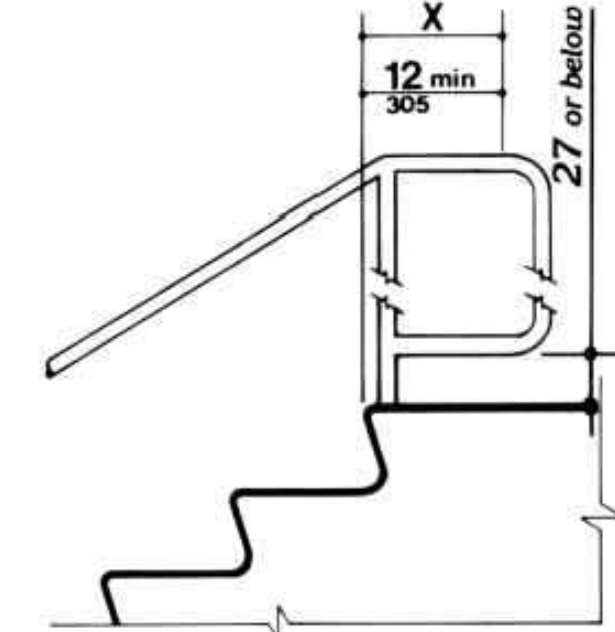
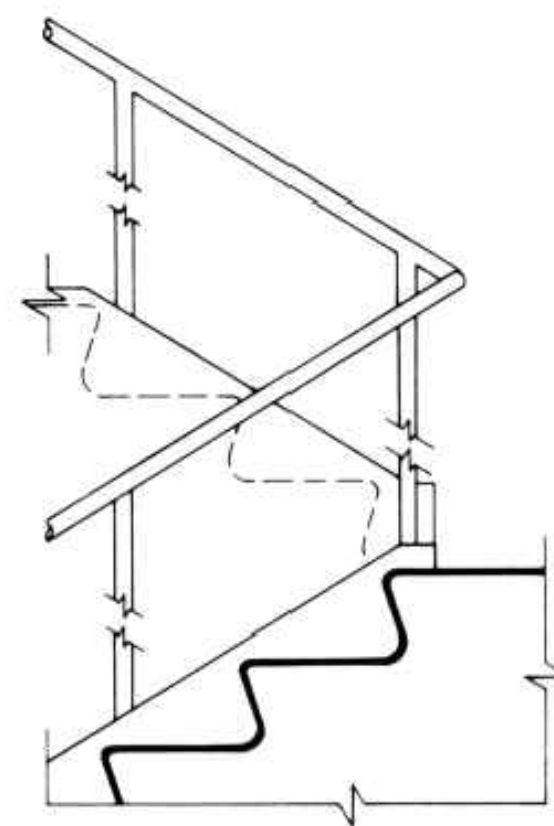
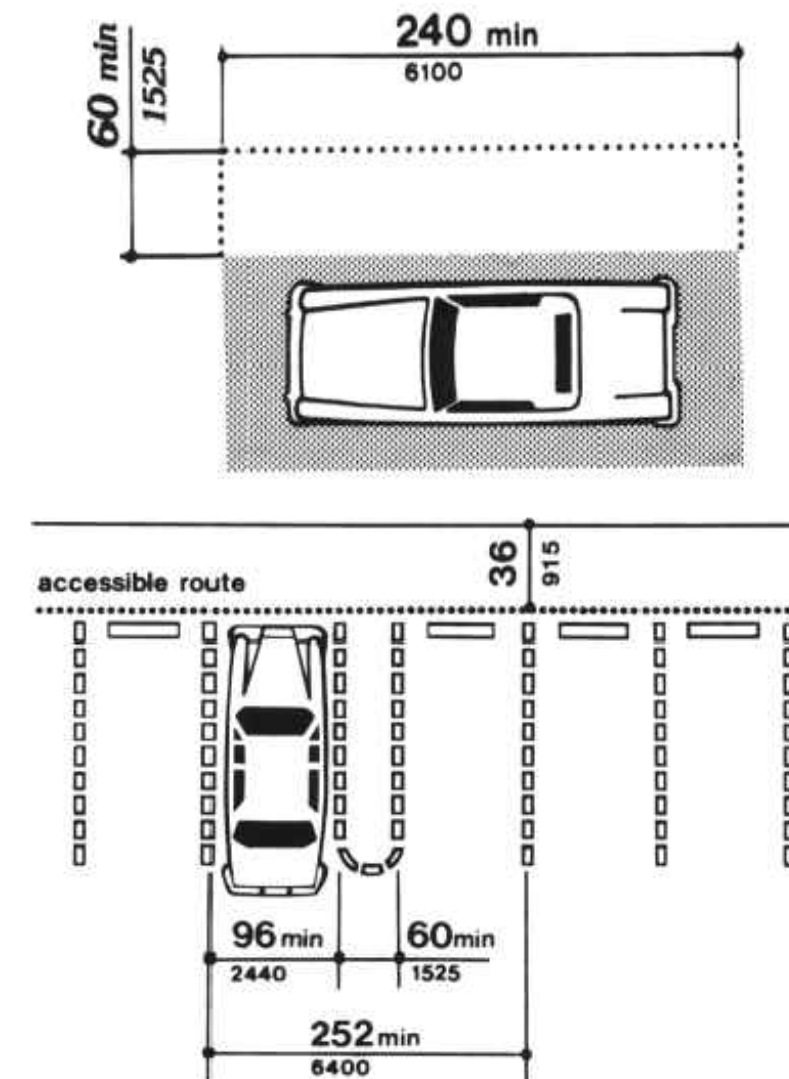

Figure 19(d)
Stair Handrails - Extension at Top of Run

Note: X is the 12 in minimum handrail extension required at each top riser. Y is the minimum handrail extension of 12 in plus the width of one tread that is required at each bottom riser.



B STANDARD UFAS PARKING SPACES
NO SCALE

J STANDARD UFAS HANDRAILS
NO SCALE

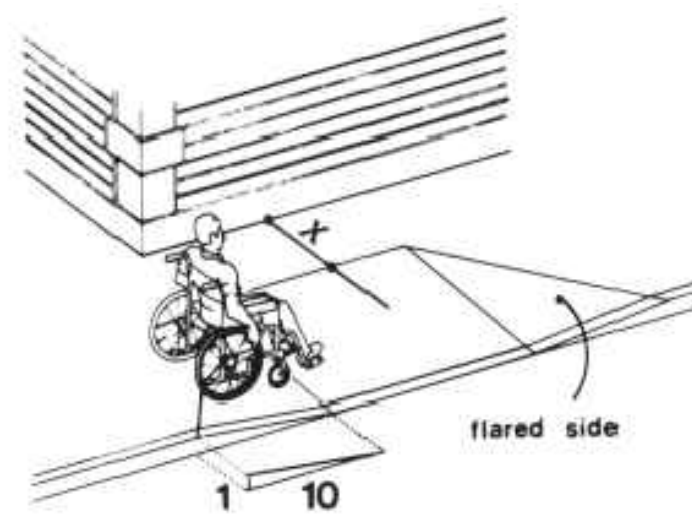

Figure 12(a)

4.7.5 SIDES OF CURB RAMPS. If a curb ramp is located where pedestrians must walk across the ramp, or where it is not protected by handrails or guardrails, then it shall have flared sides; the maximum slope of the flare shall be 1:10 (see Fig. 12(a)). Curb ramps with returned curbs may be used where pedestrians would not normally walk across the ramp (see Fig. 12(b)).

Note: If X is less than 48 inches, then the slope of the flared side shall not exceed 1:12.

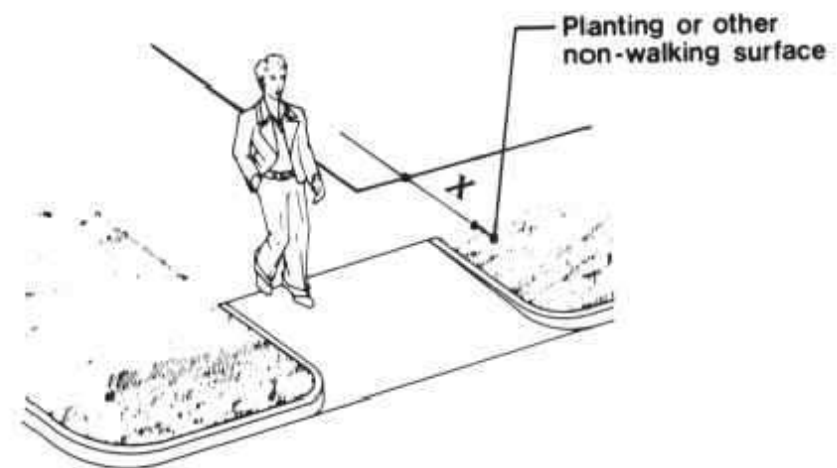
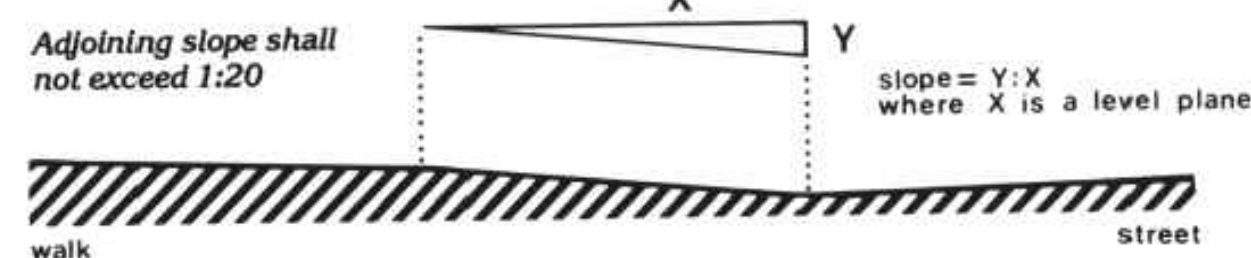
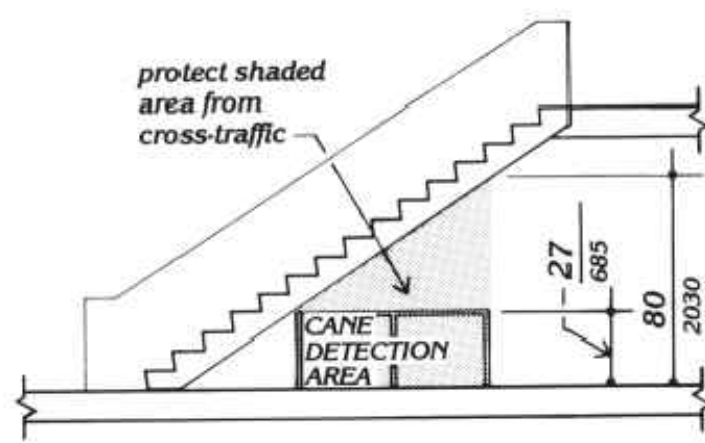

Figure 12(b)

H STANDARD UFAS CURB RAMPS
NO SCALE



G STANDARD UFAS SLOPE
NO SCALE



F GENERAL UFAS DIAGRAM
NO SCALE

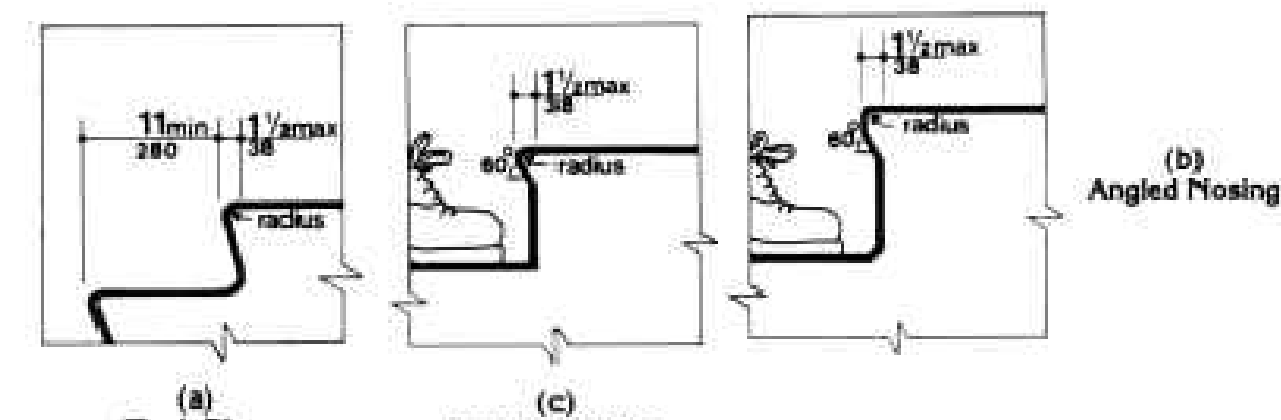

C STAIR NOSINGS
NO SCALE

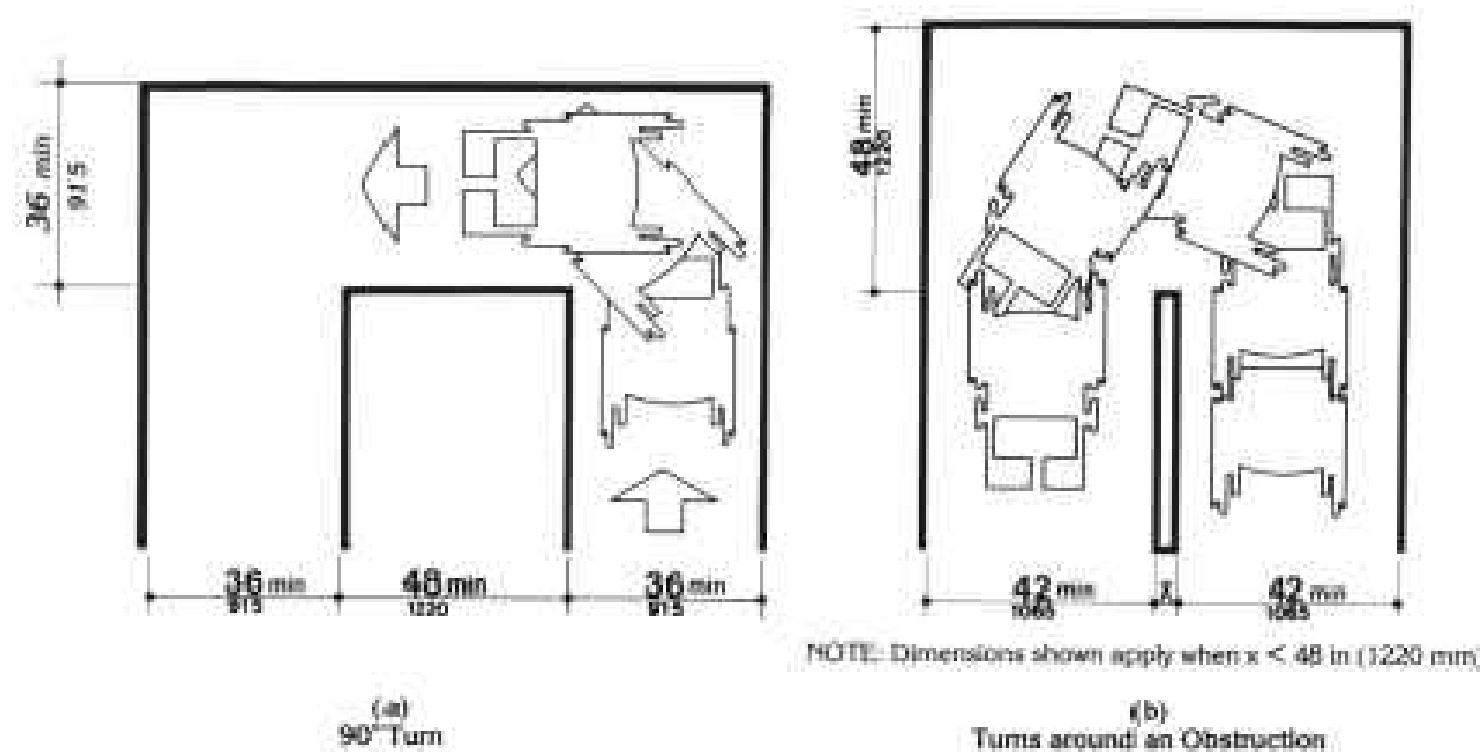

E UFAS WIDTH DIAGRAMS
NO SCALE

NOTE: Dimensions shown apply when x < 48 in (1220 mm).

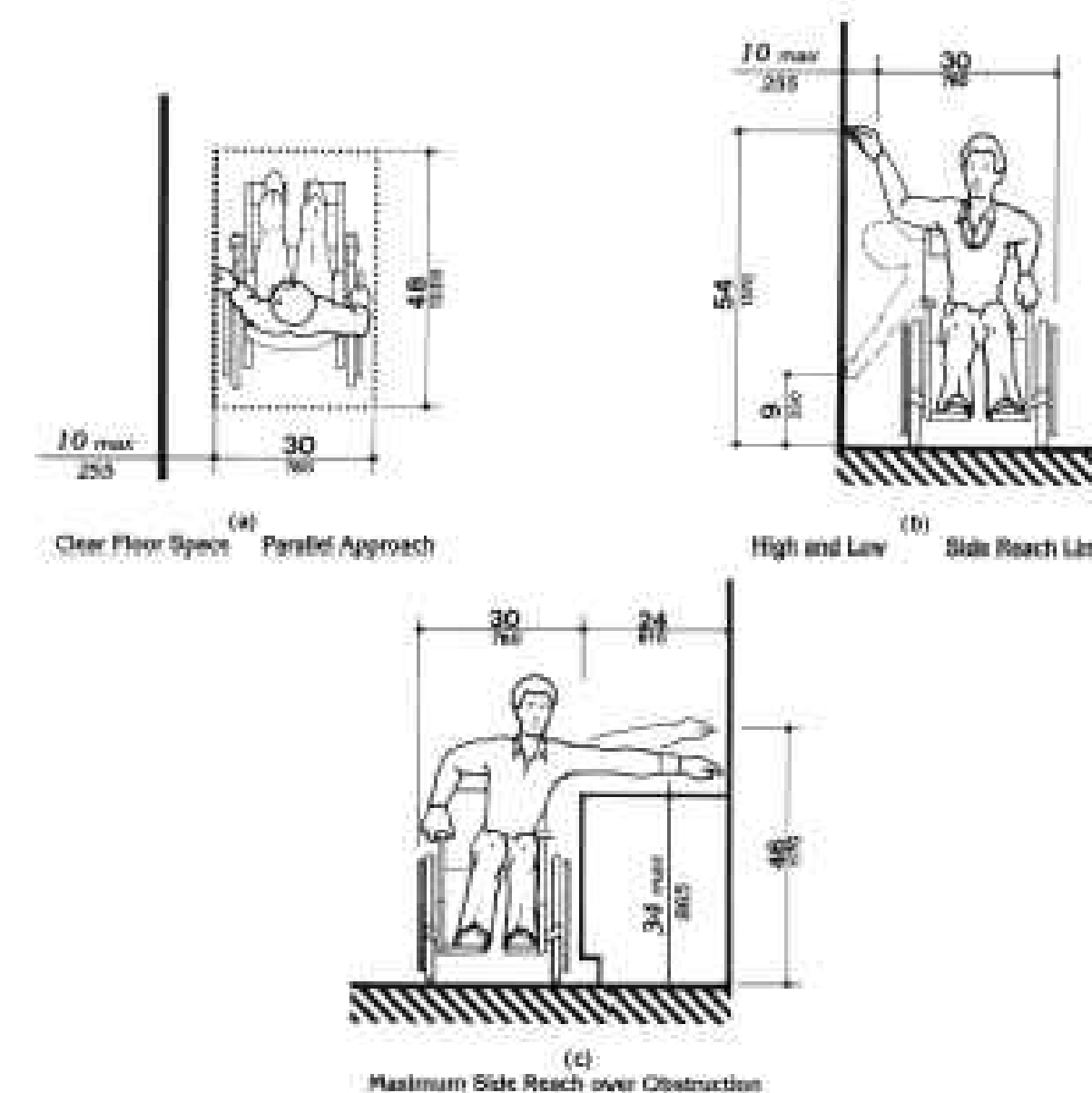

A STANDARD UFAS REACH DIAGRAMS
NO SCALE

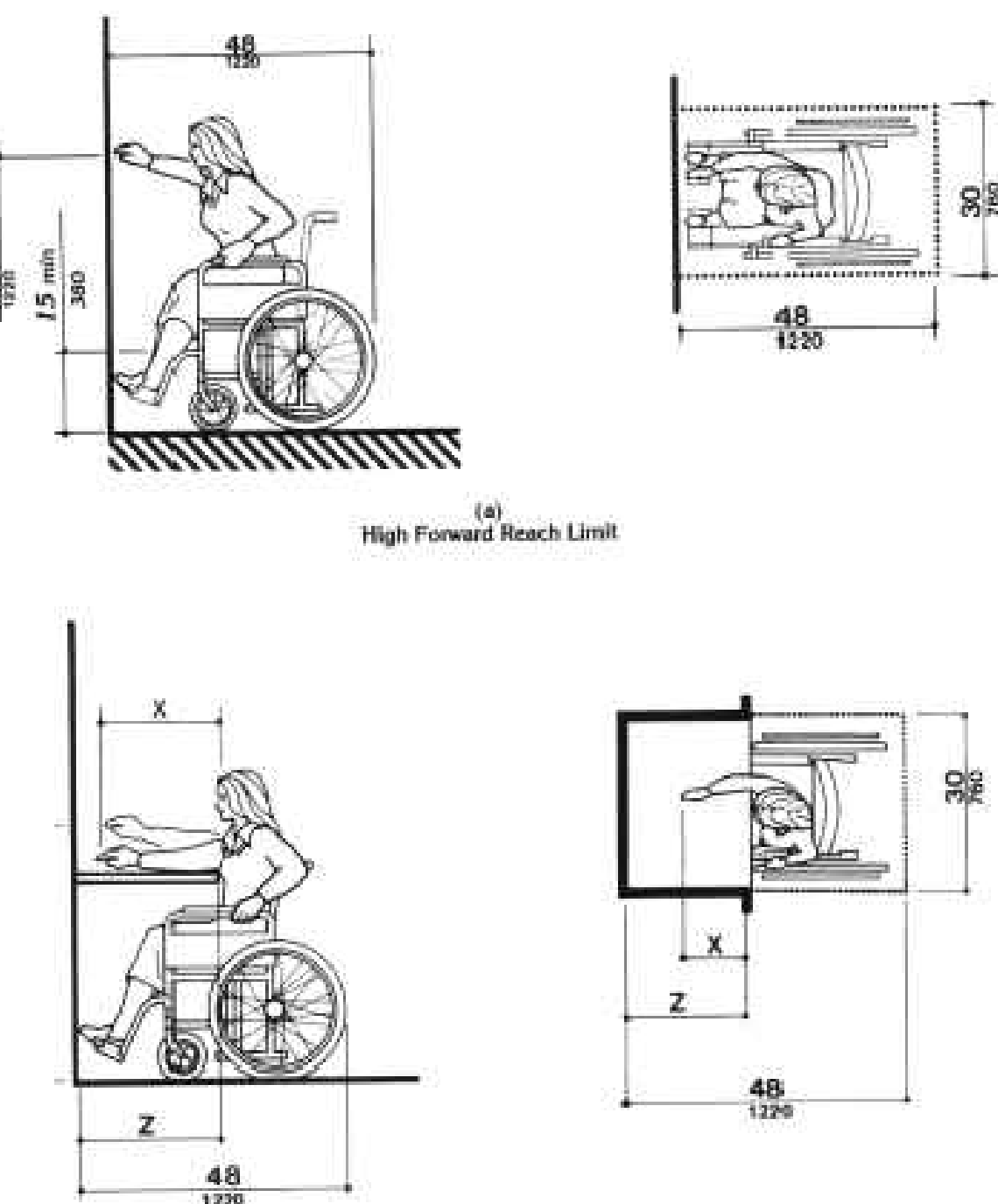

If $h \leq 25$ in (635 mm), x shall be $\geq x$. When $x < 20$ in (510 mm), then y shall be 48 in (1220 mm) maximum. If $h > 25$ in (635 mm), then y shall be 44 in (1120 mm) maximum.

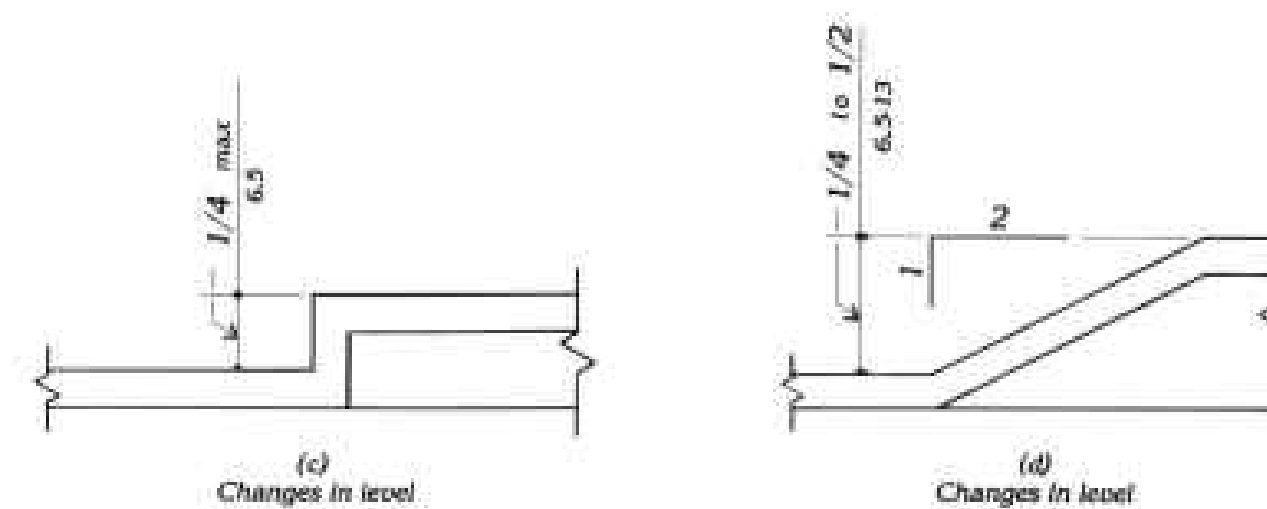

D UFAS CHANGE IN LEVEL DIAGRAM
NO SCALE

NOTE: REFERENCE FULL UNIFORM FEDERAL ACCESSIBILITY STANDARDS FOR ADDITIONAL INFORMATION.

FOR REFERENCE ONLY

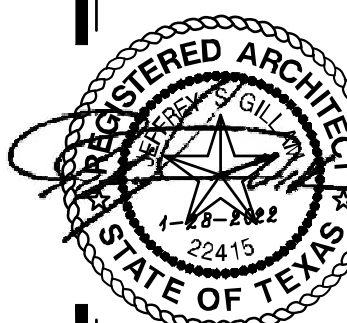
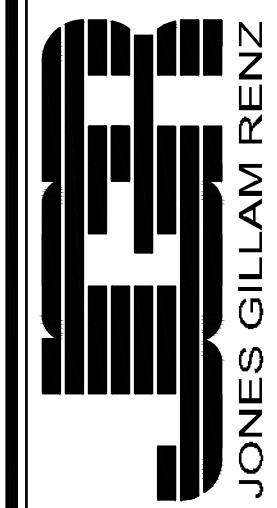

REVISION:
DATE:
JOB:
SHEET:

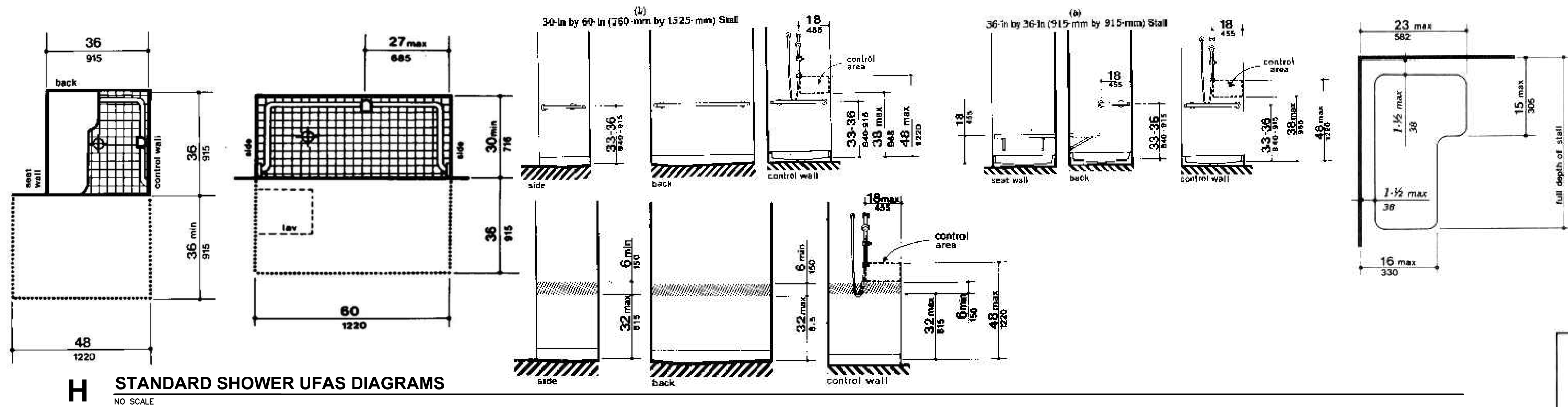

H STANDARD SHOWER UFAS DIAGRAMS
NO SCALE

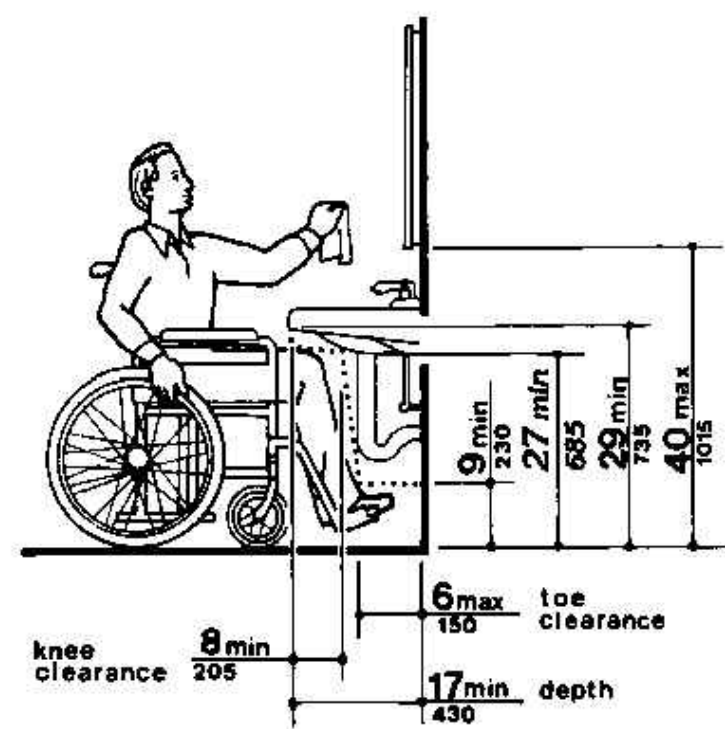

G UFAS LAVATORY CLEARANCES
NO SCALE

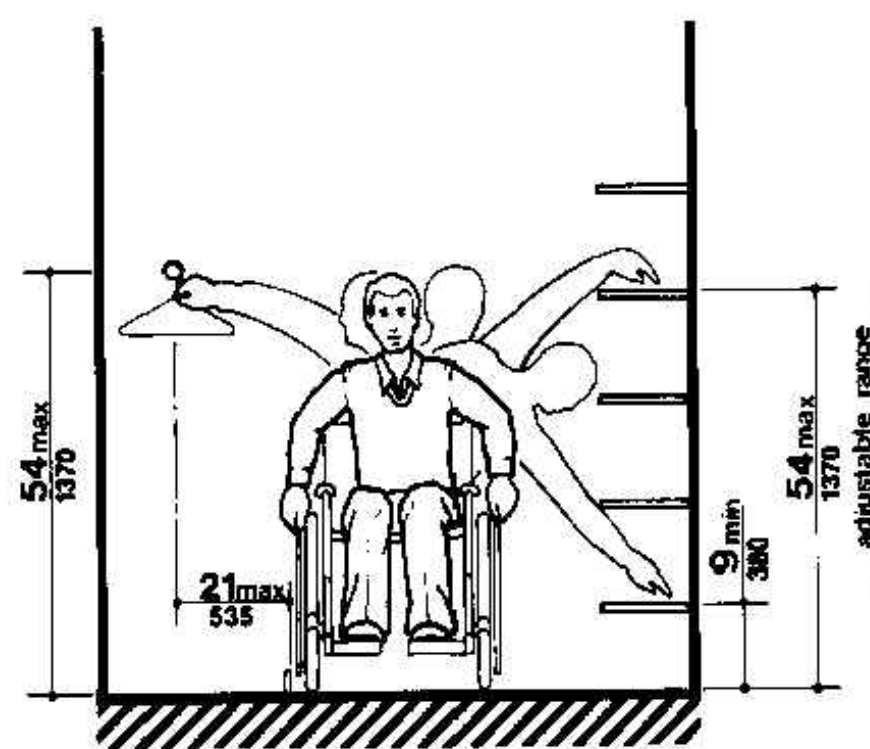

F STANDARD UFAS CLOSET/STORAGE HEIGHT
NO SCALE

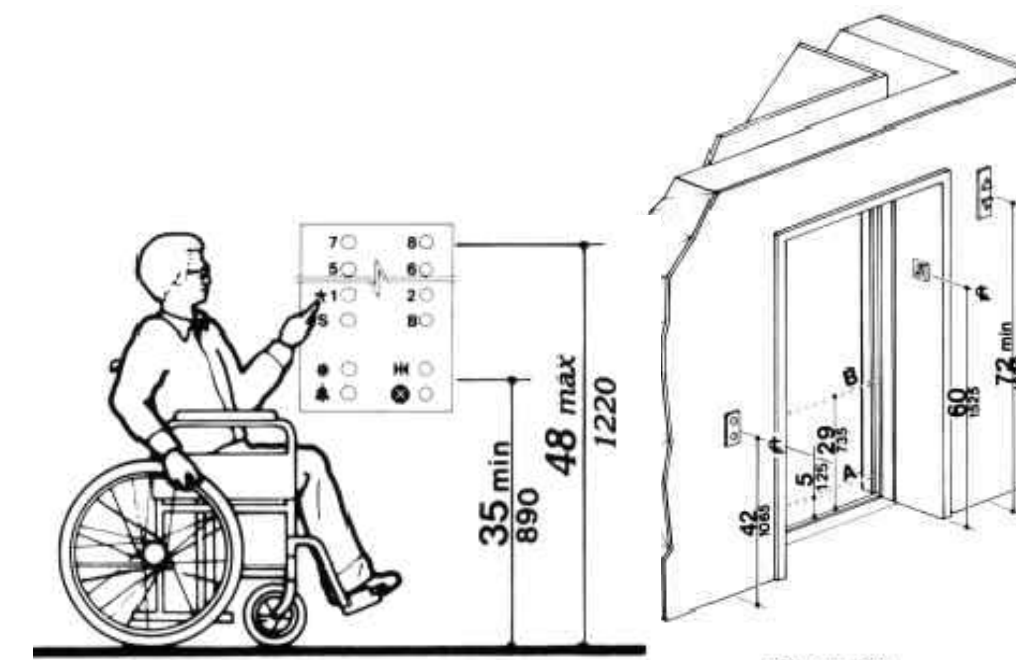
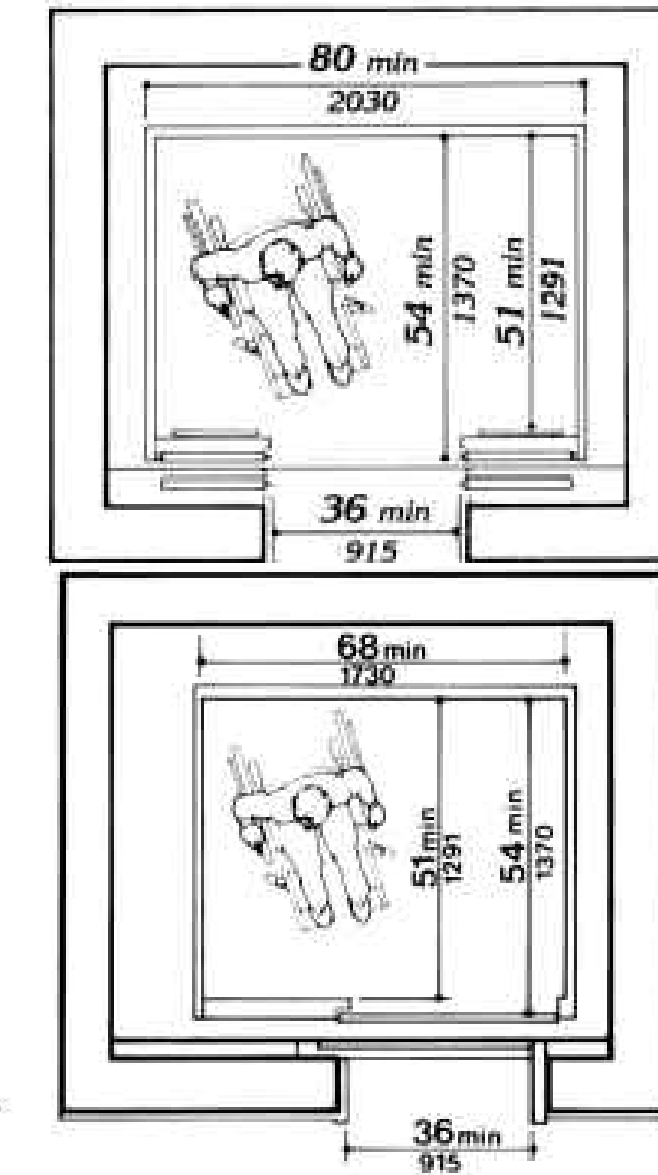

Figure 20
Hoistway and Elevator Entrances

Note: The automatic door reopening device is activated if an object passes through either line A or line B. Line A and line B represent the vertical locations of the door reopening device not requiring contact.



E STANDARD UFAS ELEVATOR DETAILS
NO SCALE

SYMBOL KEY:

1. Countertop or wall-mounted oven.
2. Pull-out board preferred with side-opening door.
3. Clear open space.
4. Bottom-hinged door.

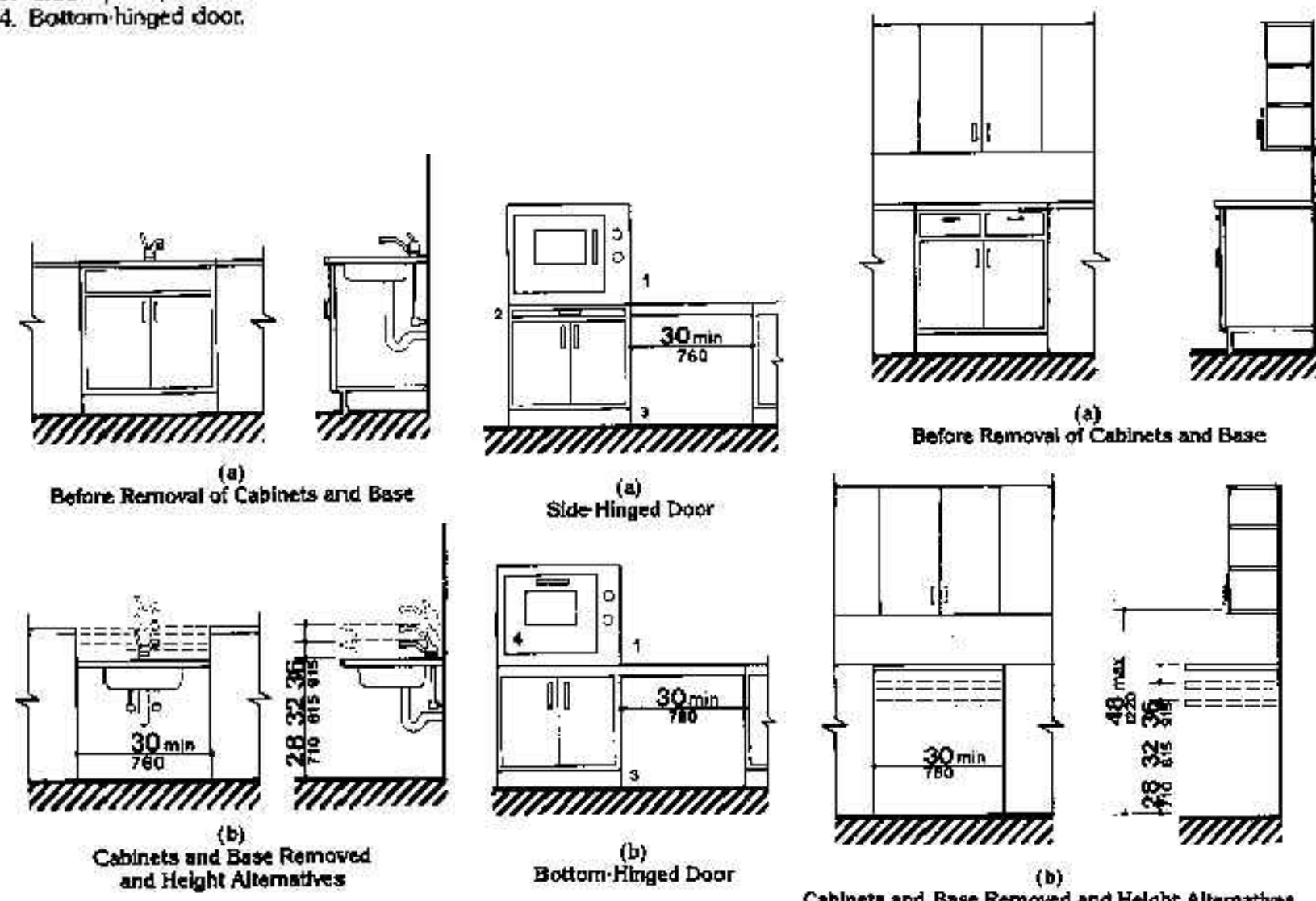

D STANDARD UFAS KITCHEN DIAGRAMS
NO SCALE

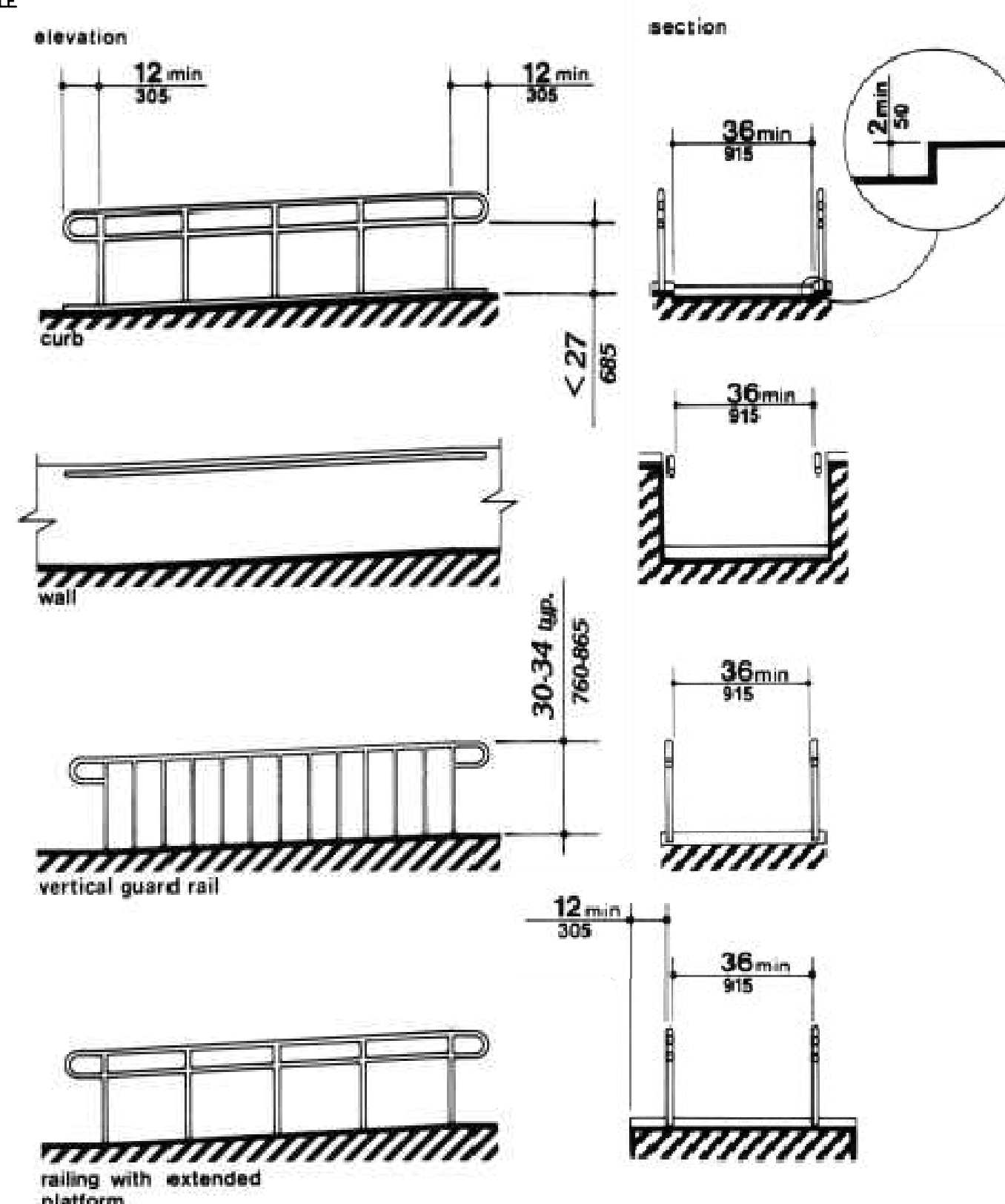

C UFAS EDGE PROTECTION
NO SCALE

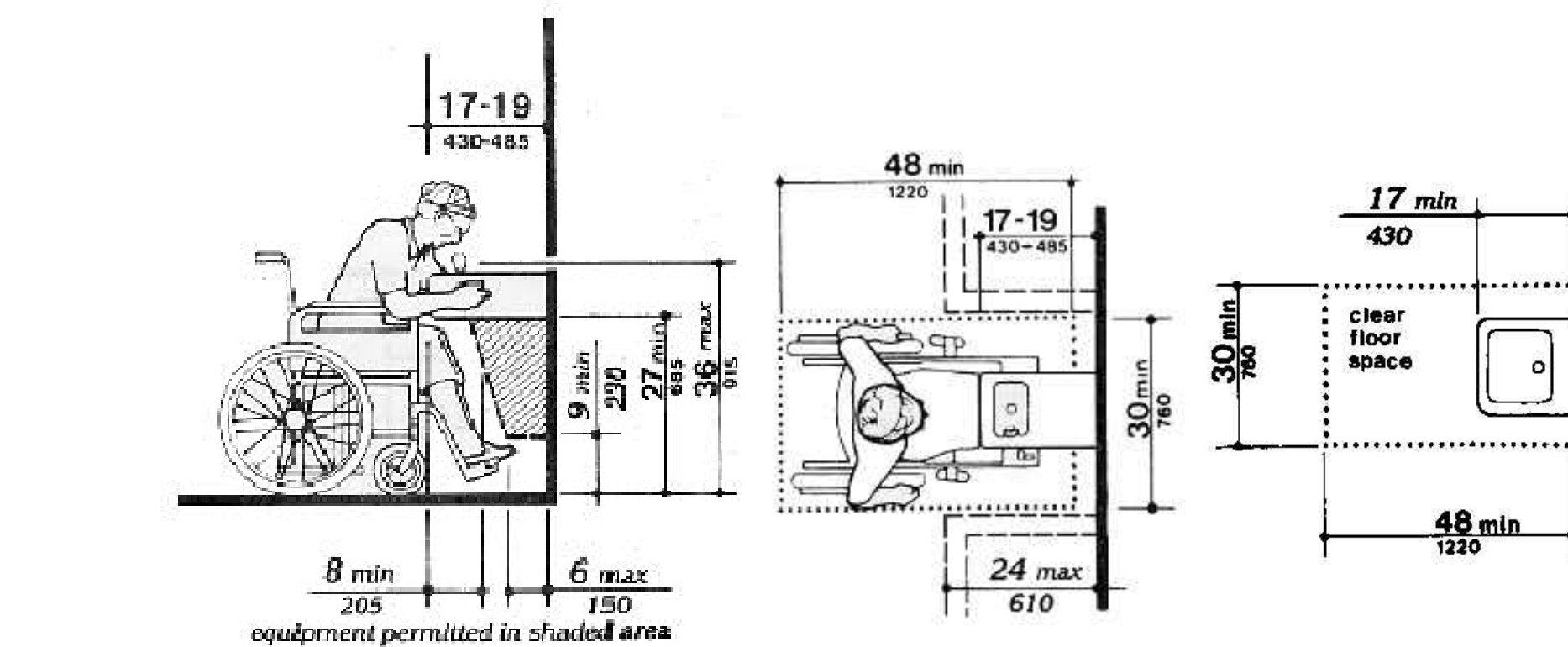

B STANDARD UFAS DRINKING FOUNTAIN CLEARANCE
NO SCALE

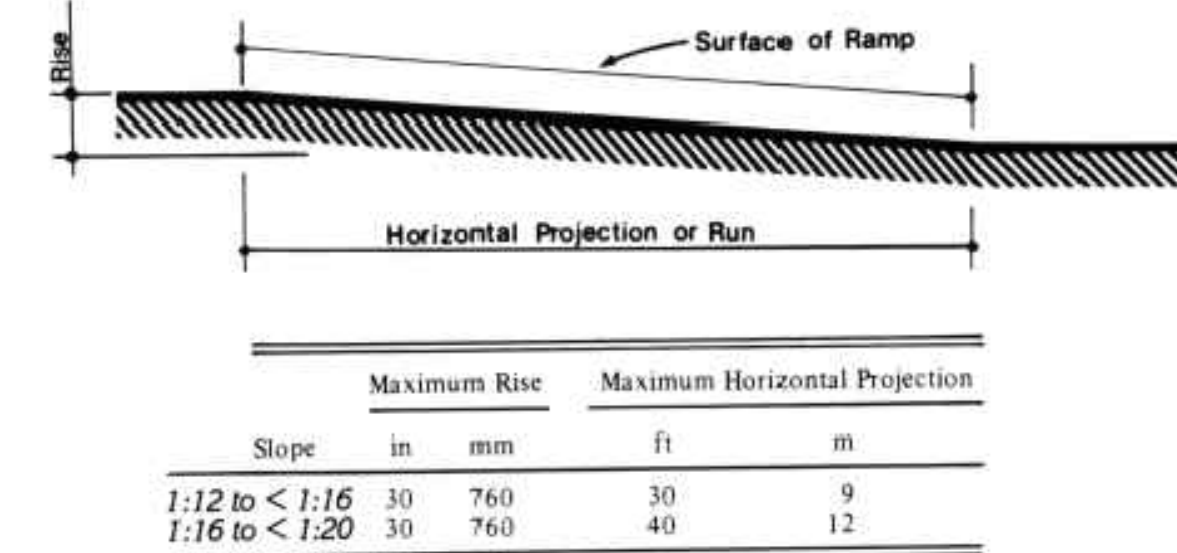

A SLOPE AND RISE
NO SCALE

NOTE: REFERENCE FULL UNIFORM FEDERAL ACCESSIBILITY STANDARDS FOR ADDITIONAL INFORMATION.

FOR REFERENCE ONLY

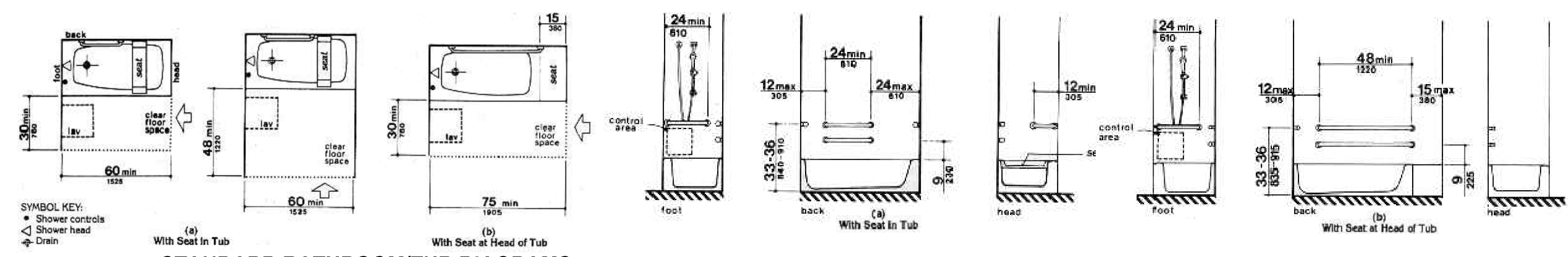
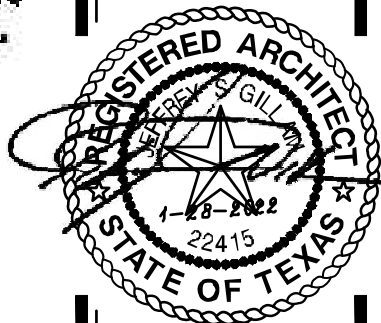

C STANDARD BATHROOM/TUB DIAGRAMS
 NO SCALE

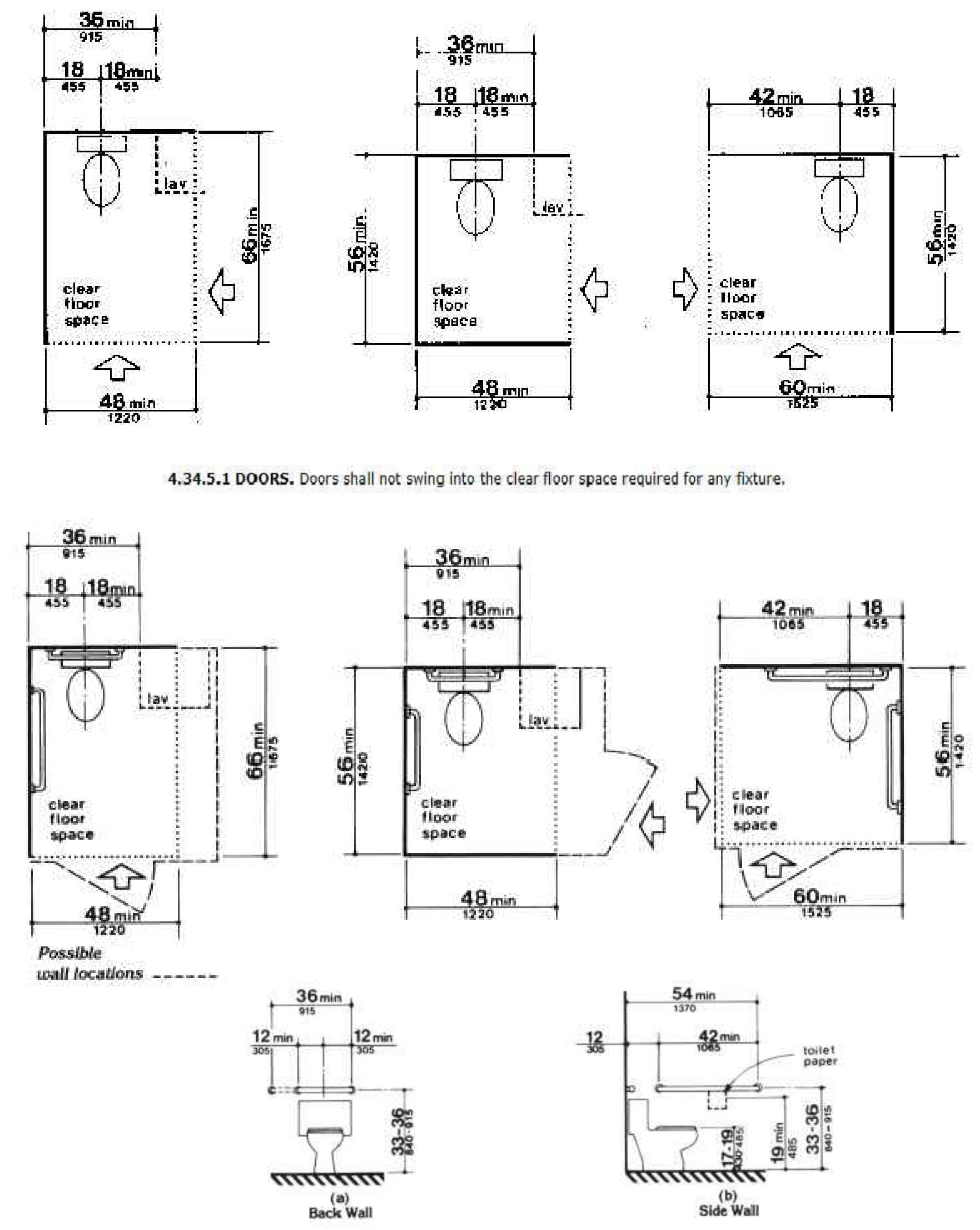
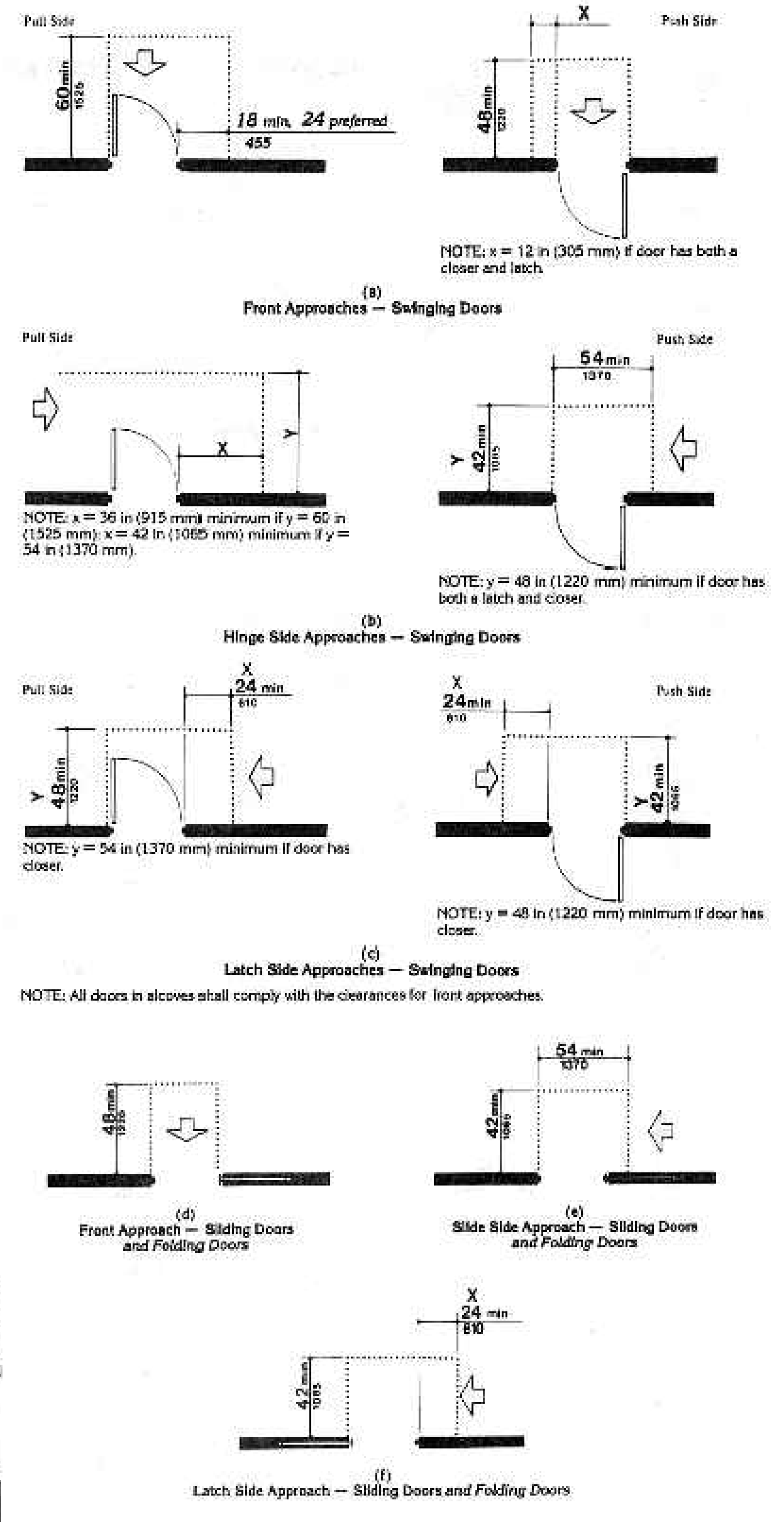

A STANDARD UFAS TOILET/WATER CLOSET DIAGRAMS
 NO SCALE

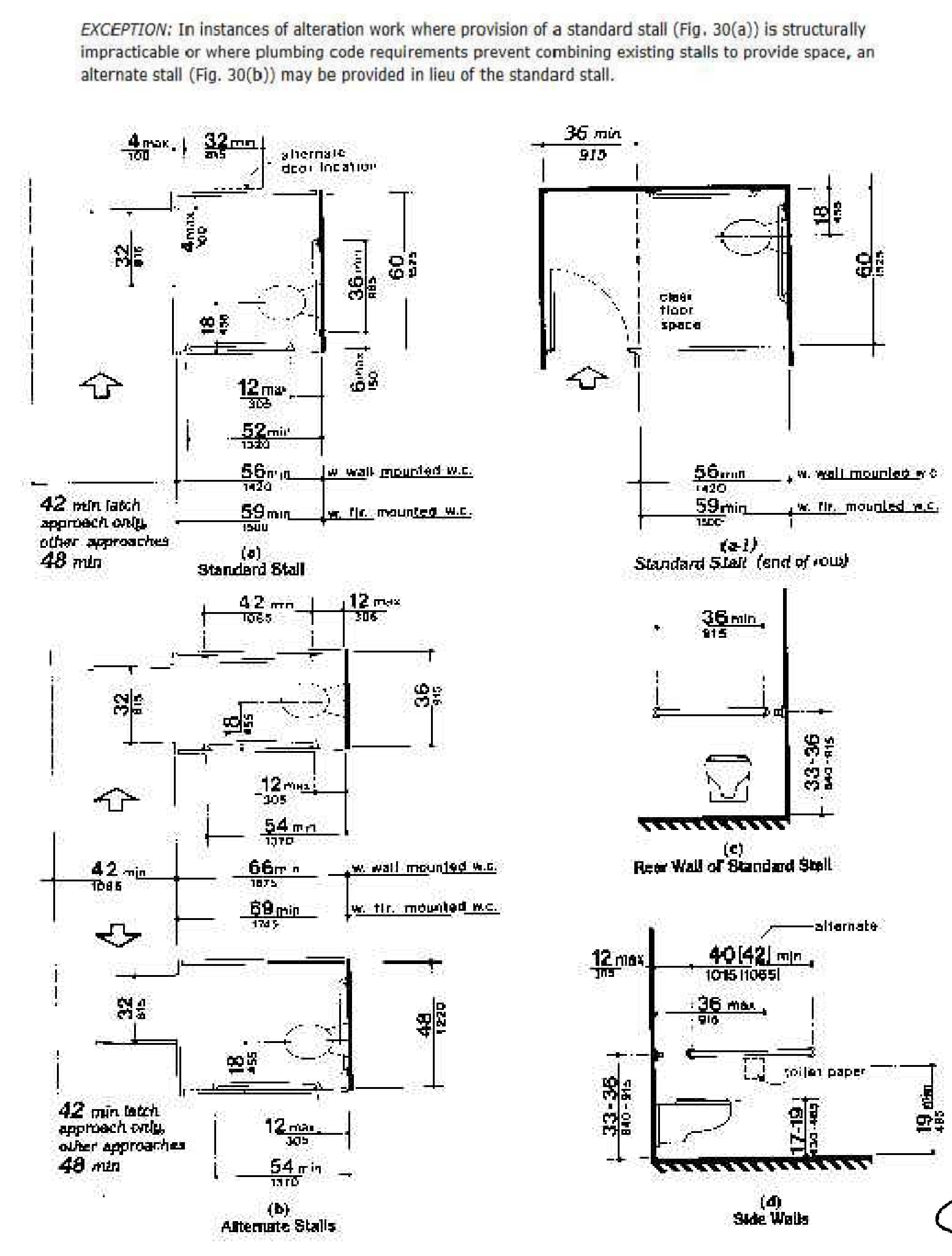

NOTE:
 REFERENCE FULL UNIFORM FEDERAL
 ACCESSIBILITY STANDARDS FOR
 ADDITIONAL INFORMATION.

FOR REFERENCE ONLY

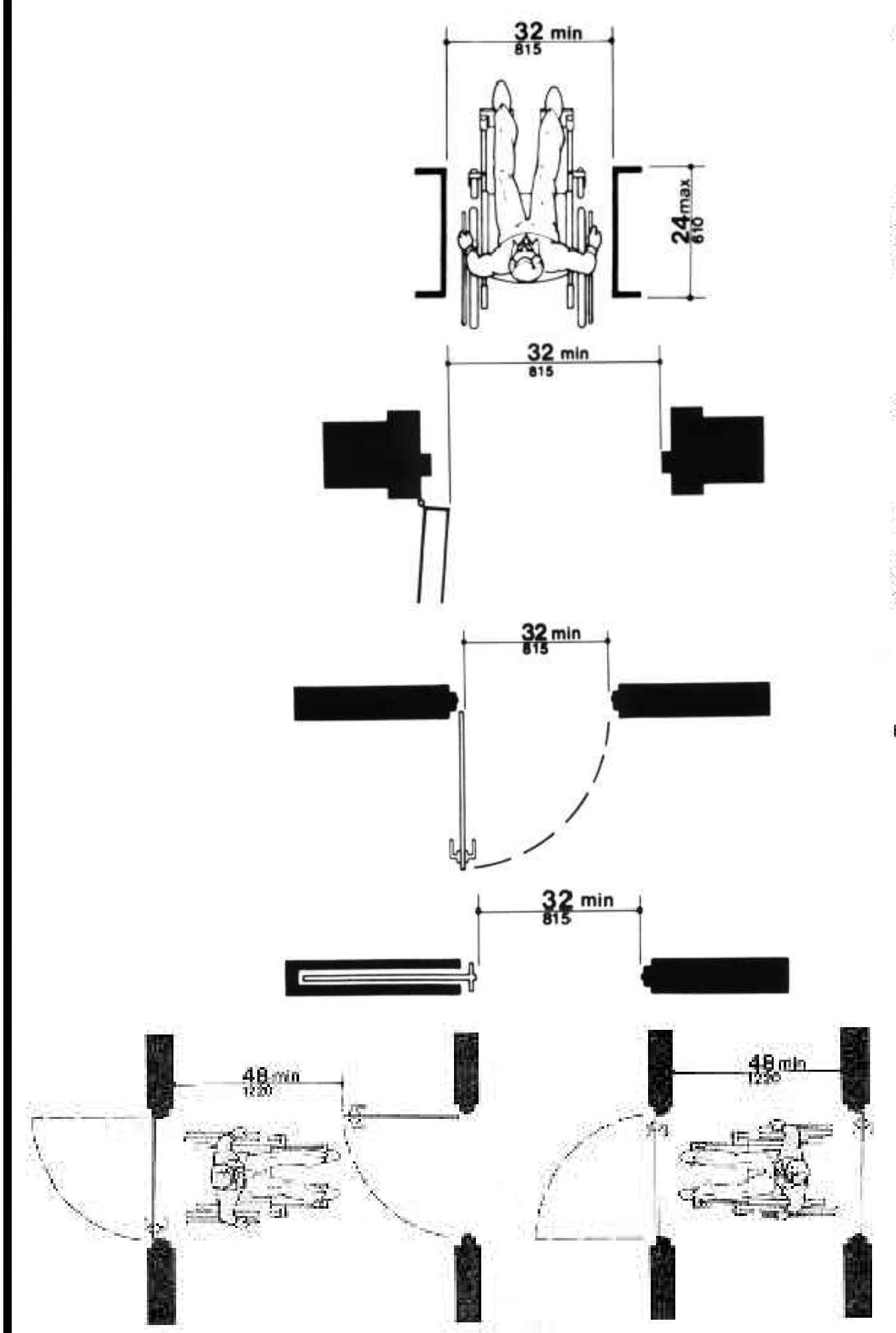

B STANDARD UFAS DOOR APPROACH/CLEARANCES
 NO SCALE

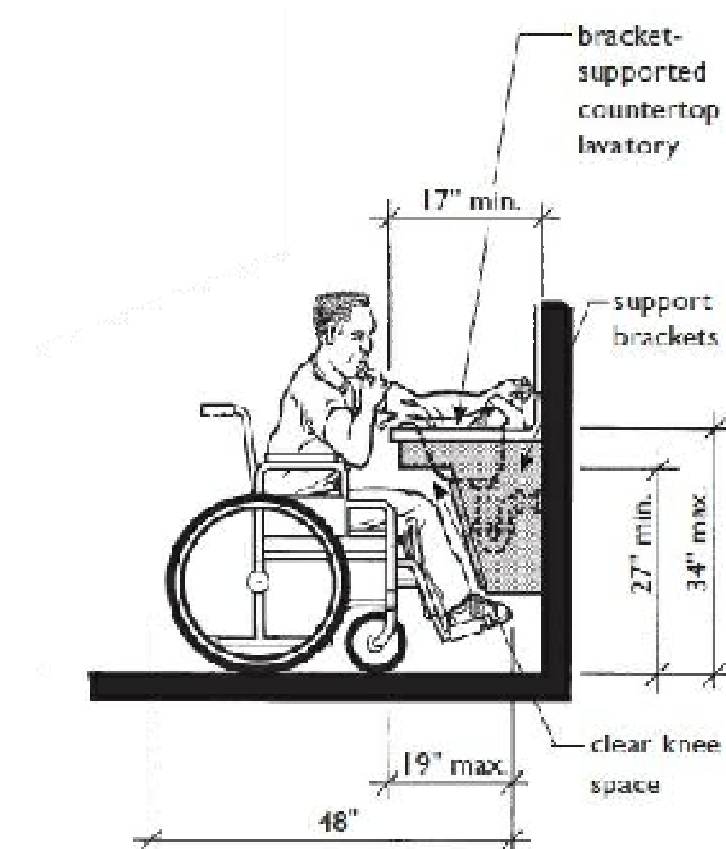

Knee Space at Lavatories that Meets the Requirements for B Bathrooms

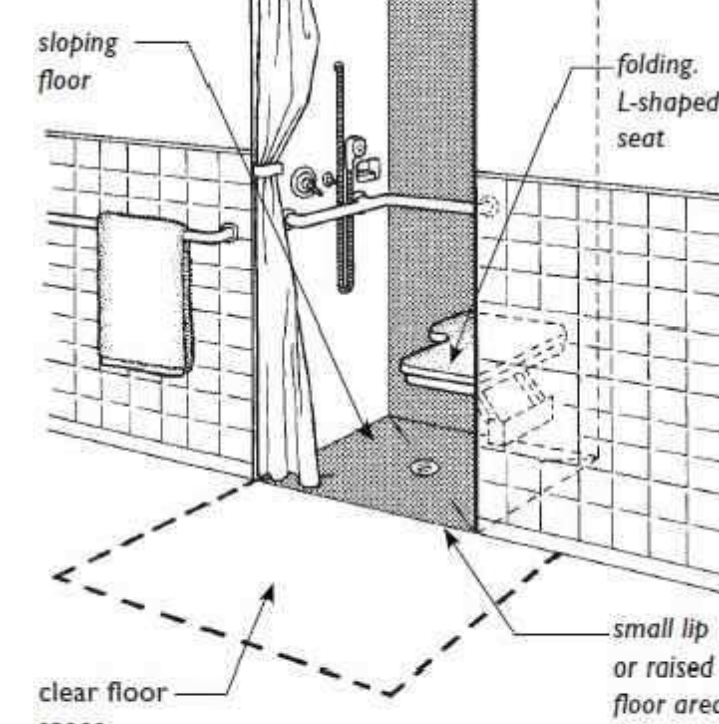

36-Inch X 36-Inch Shower with Folding Seat

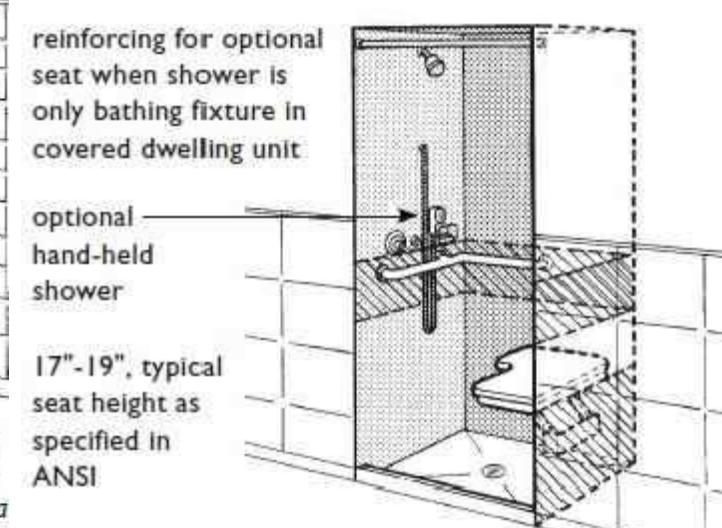

Seat and Grab Bar in 36" X 36" Shower

Knee Space at Sink with Wrapped Pipes

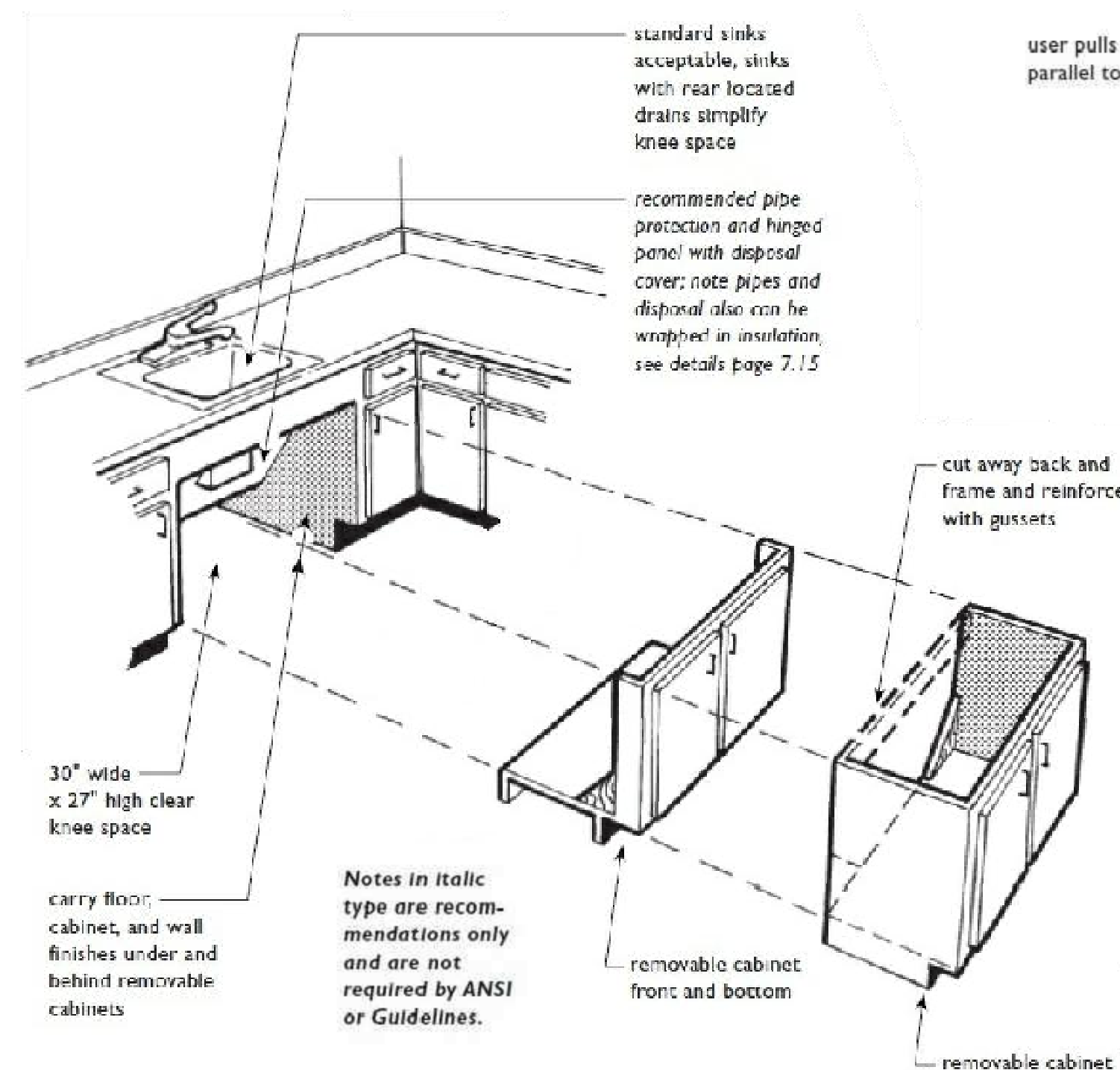
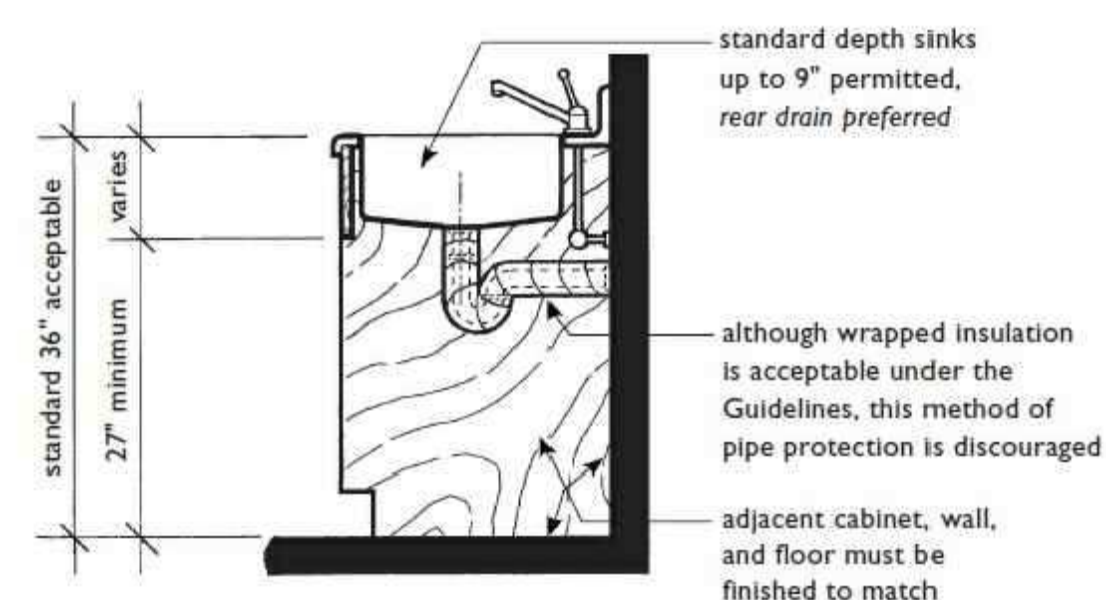

Possible Removable Cabinet Options for Required Knee Spaces at Sinks or Cooktops in Narrow (Less Than 60" Wide) U-Shaped Kitchens

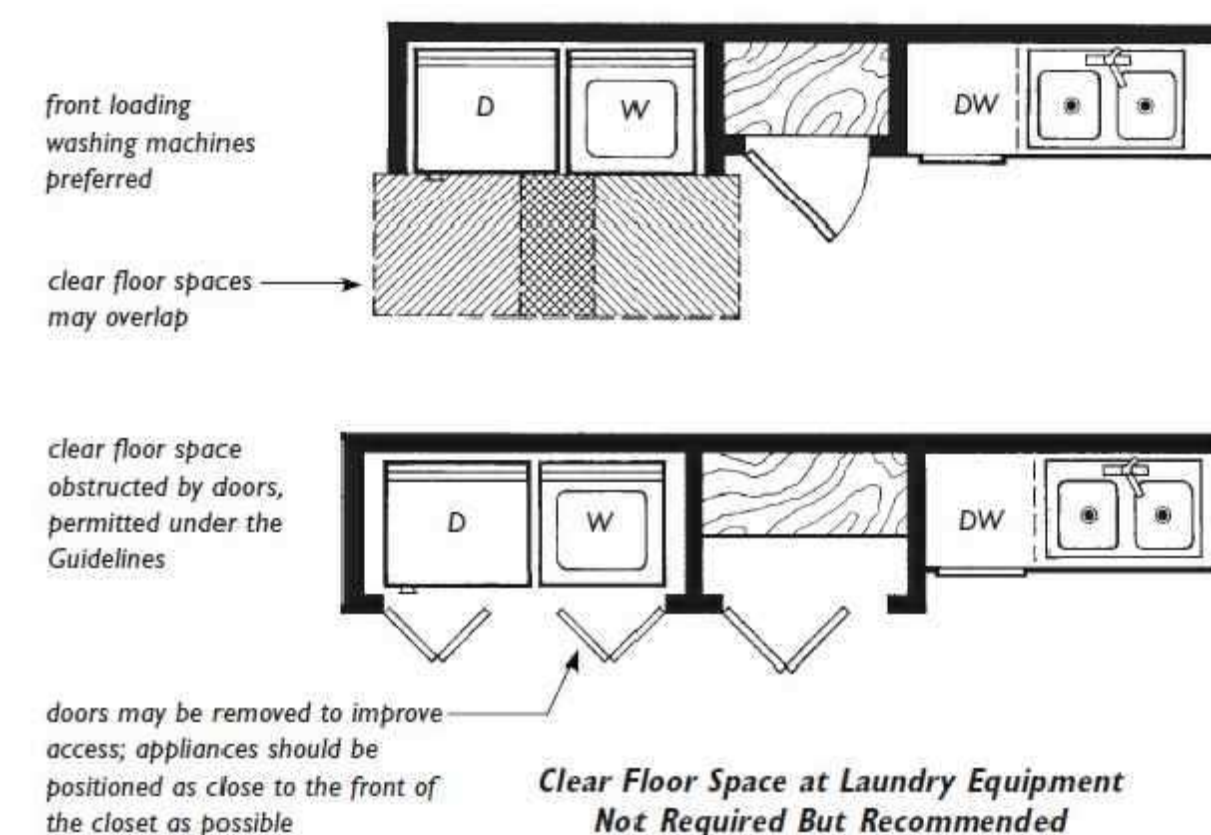

Clear Floor Space at Laundry Equipment Not Required But Recommended

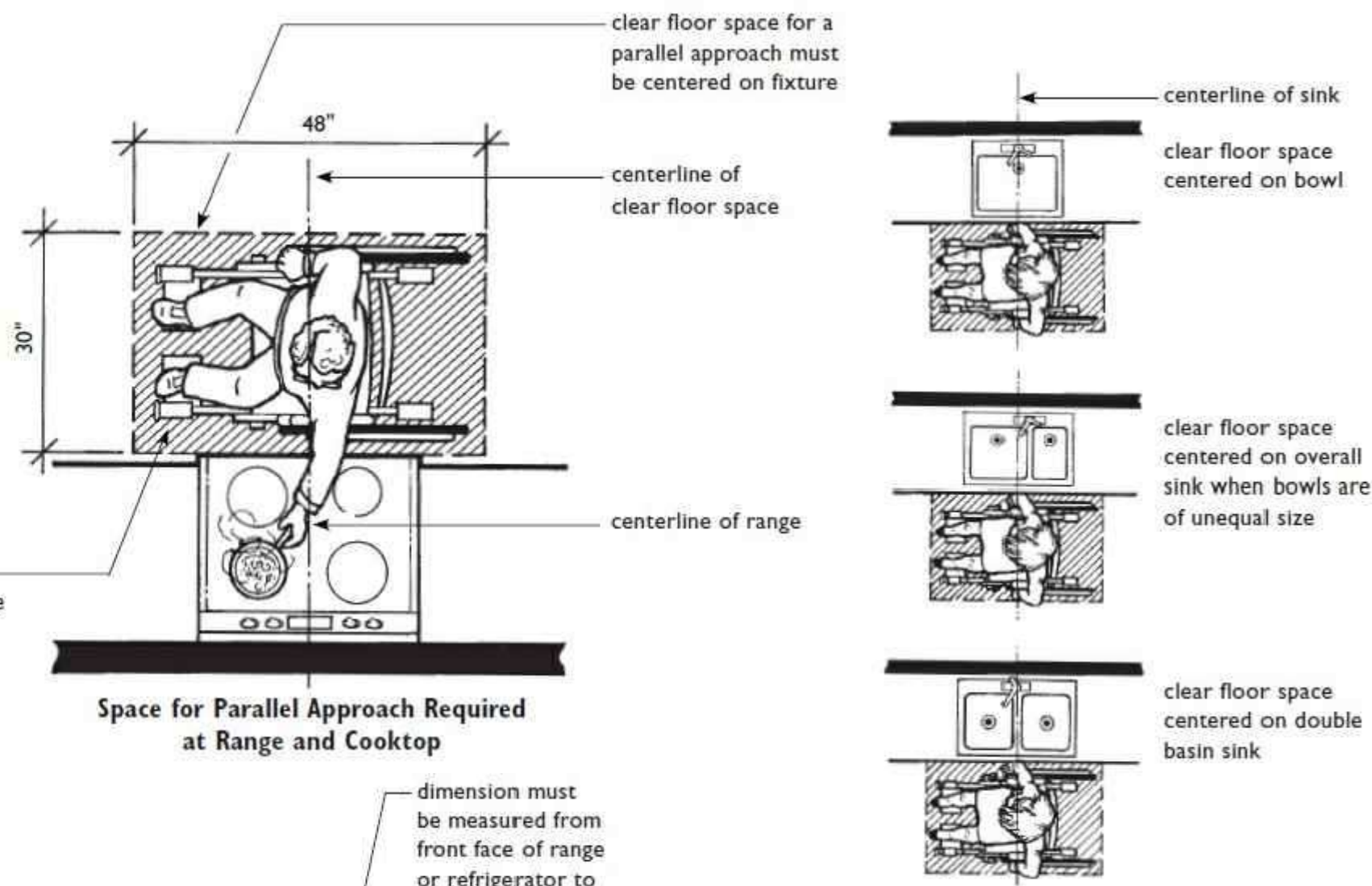

Space for Parallel Approach Required at Range and Cooktop

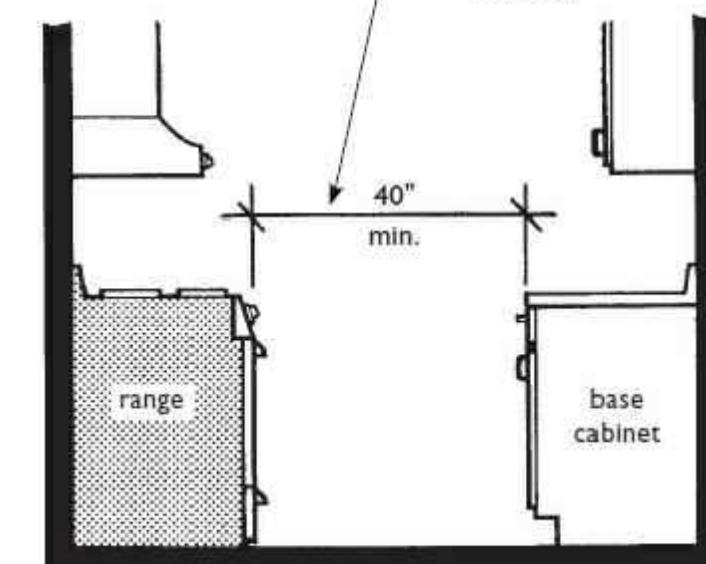

Minimum Clearance between Range and Opposing Base Cabinet

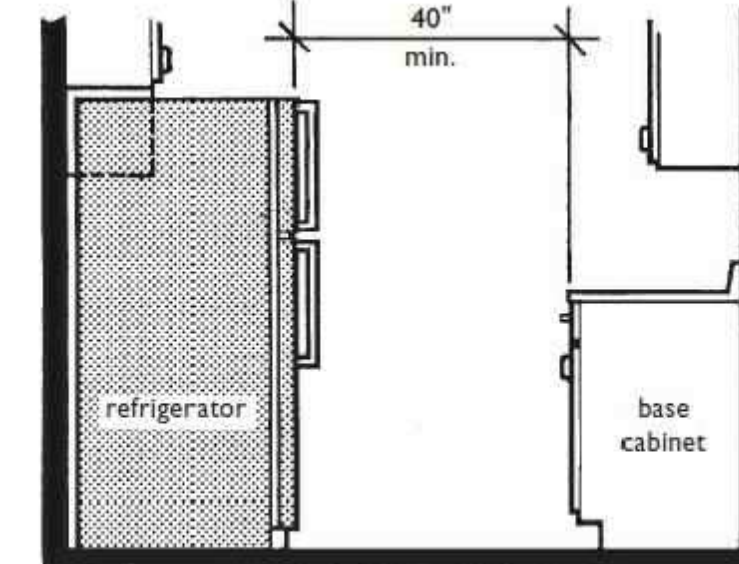

Minimum Clearance between Refrigerator and Opposing Base Cabinet

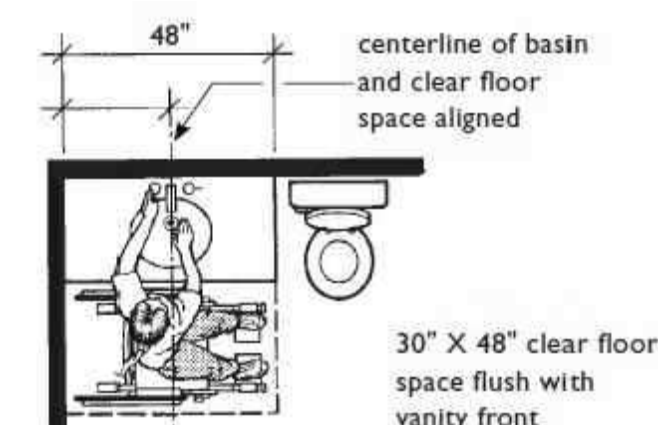

Removable Base Cabinet Not Required Because Clear Floor Space Centered on Basin (Applicable in A and B Bathrooms)

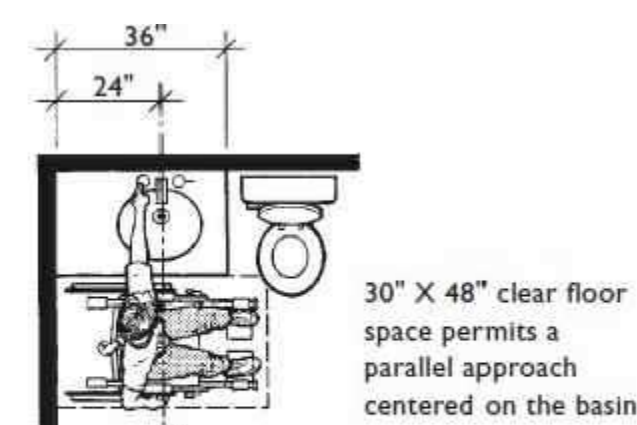

Use of Offset Basin to Reduce Lavatory Length (Applicable in A and B Bathrooms)

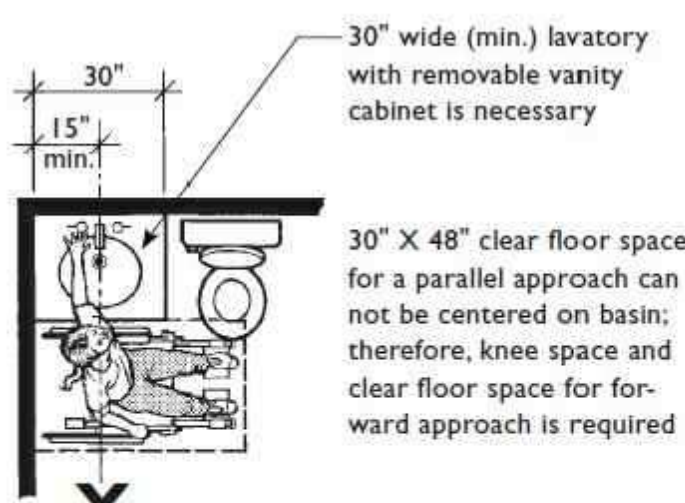

Removable Base Cabinet Must Be Provided Because Clear Floor Space Can Not Be Centered (Required in A and B Bathrooms)

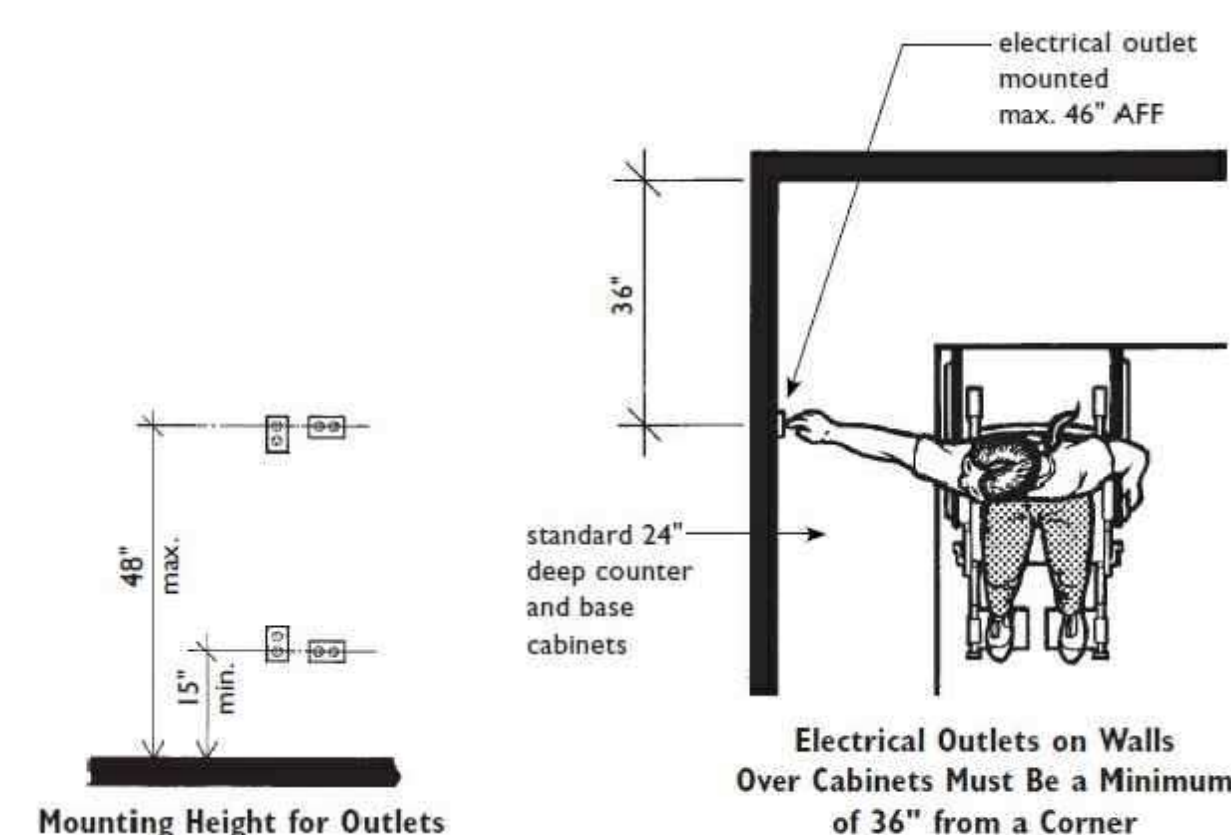

Mounting Height for Outlets

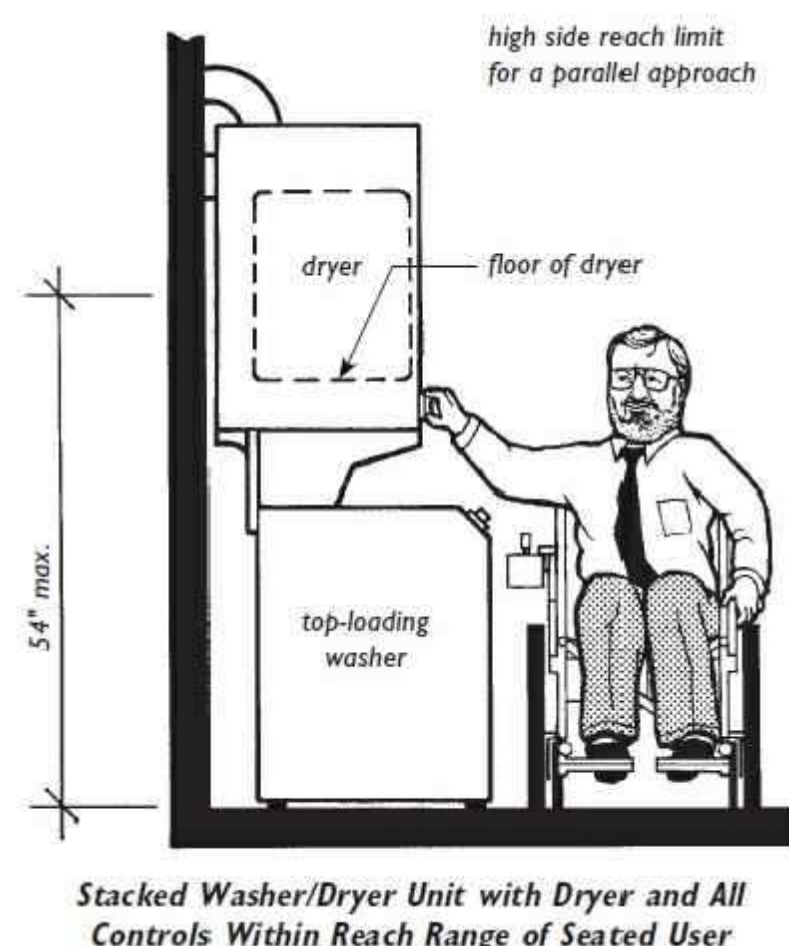

Stacked Washer/Dryer Unit with Dryer and All Controls Within Reach Range of Seated User

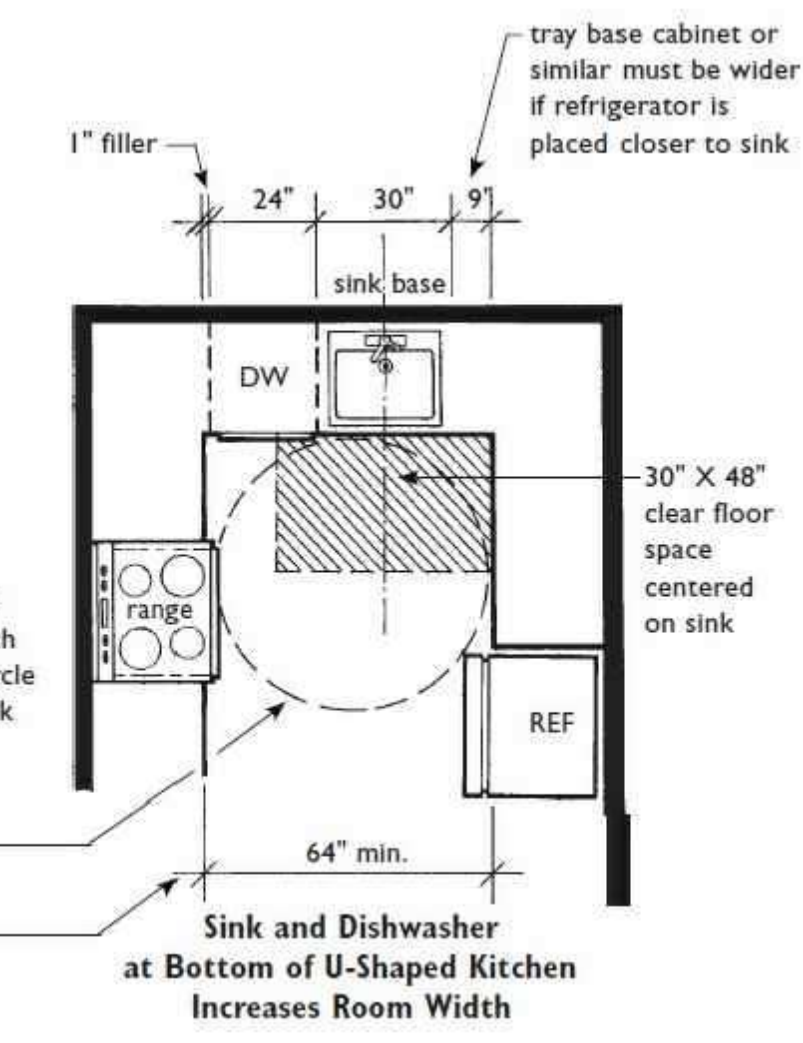

refrigerator must be selected and positioned so it does not encroach upon the 60" diameter turning circle or the clear floor space at the sink

this dimension may need to be increased slightly for a double basin sink if wider than 30"

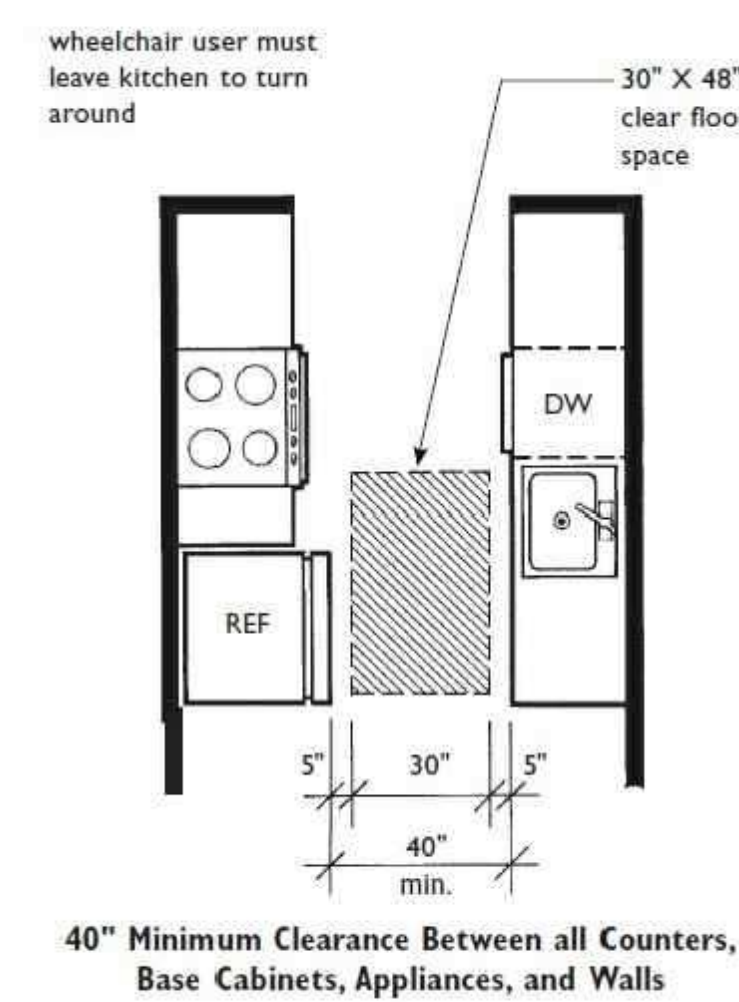

40" Minimum Clearance Between all Counters, Base Cabinets, Appliances, and Walls

FOR REFERENCE ONLY



REVISION:	
DATE:	1-28-2022
JOB:	21-3137
SHEET:	

FH (UFAS)

Architects Planners Designers
1881 Main Street, Suite 301
Kansas City, MO 64108
730 N. Ninth
P.O. Box 28208
Salina, KS 67402
785.827.0386
jgr@jgrarchitects.com

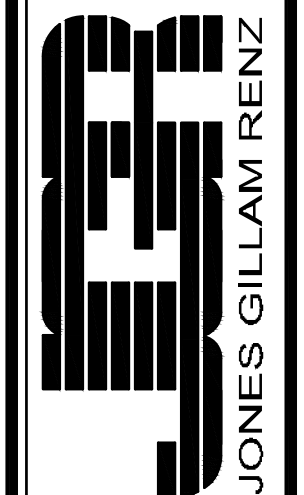

CLIFTON RIVERSIDE APARTMENTS
NEW APARTMENTS
FORT WORTH, TEXAS

COORDINATED WITH UFAS

COPYRIGHTED ©

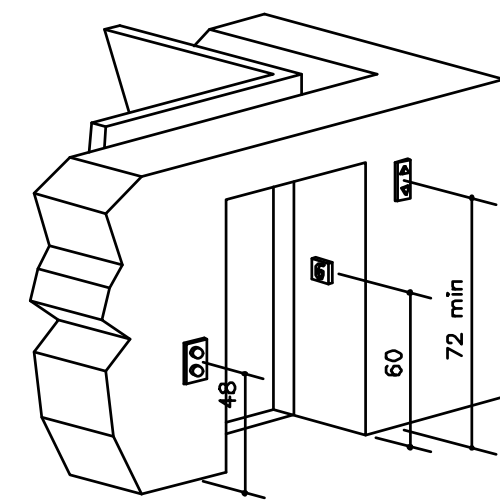

Hoistway and Elevator Entrances

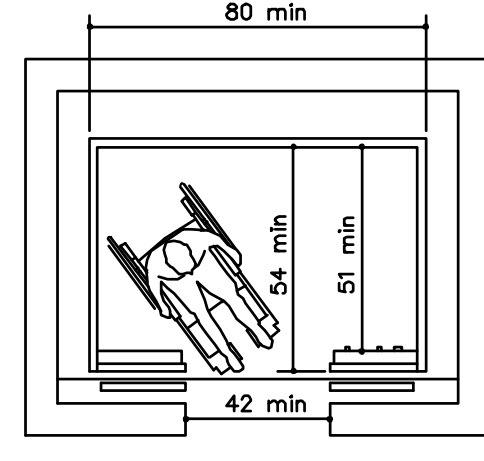

Minimum Dimensions for Elevator Car

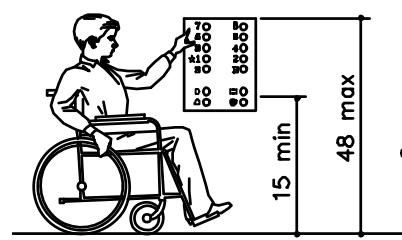

Car Control Height

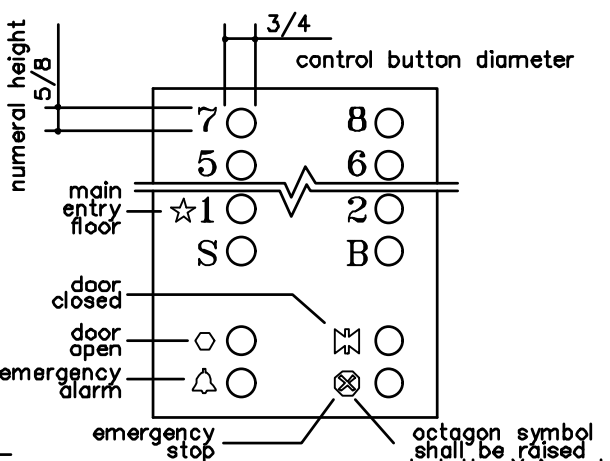

Panel Detail

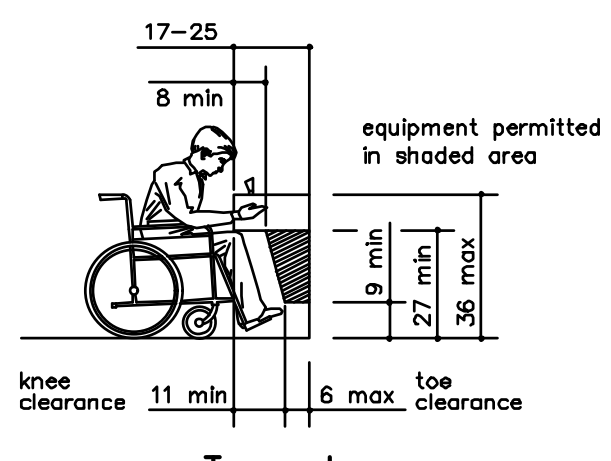

Toe and Knee Clearance Elevation

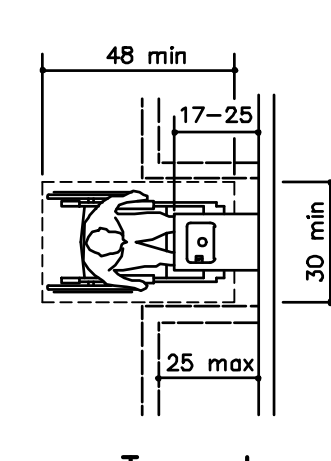

Toe and Knee Clearance Plan

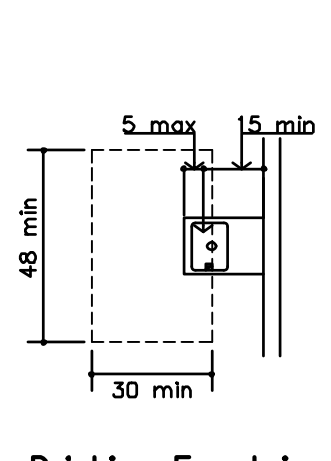

Drinking Fountain Spout Location

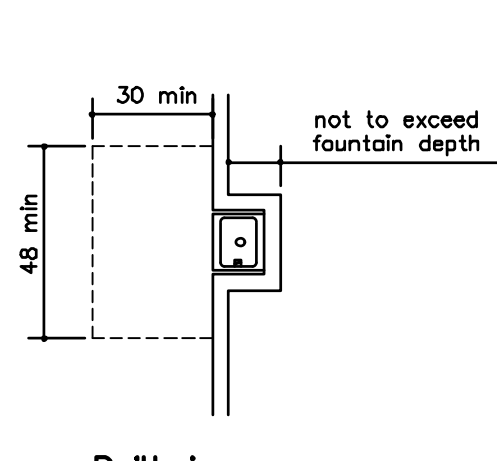

Built-in Fountain or Cooler

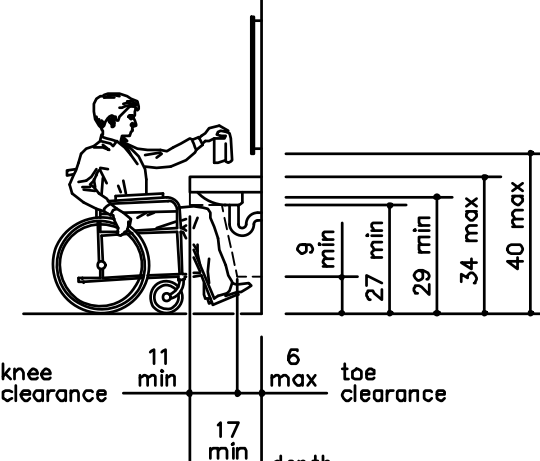

Lavatory Clearances

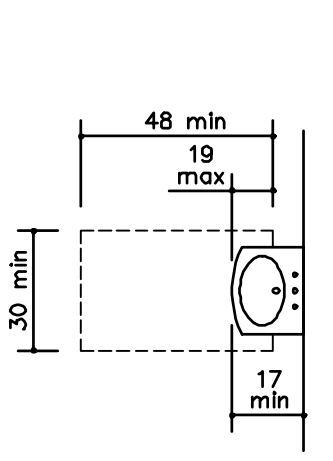

Clear Floor Space at Lavatories

M STANDARD ELEVATOR DIAGRAMS

NO SCALE

L STANDARD DRINKING FOUNTAIN DETAILS

NO SCALE

K STANDARD LAVATORY DETAILS

NO SCALE

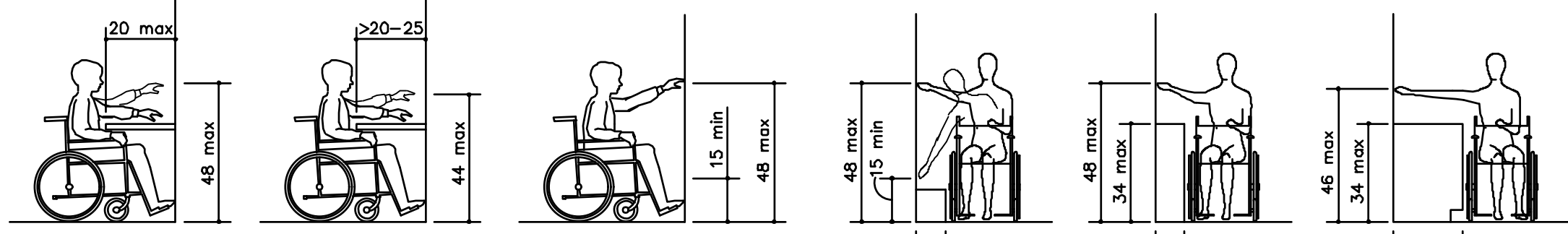

Obstructed High Forward Reach, Unobstructed Forward Reach, Unobstructed Side Reach, Obstructed High Side Reach

J STANDARD REACH TSA DIAGRAMS

NO SCALE

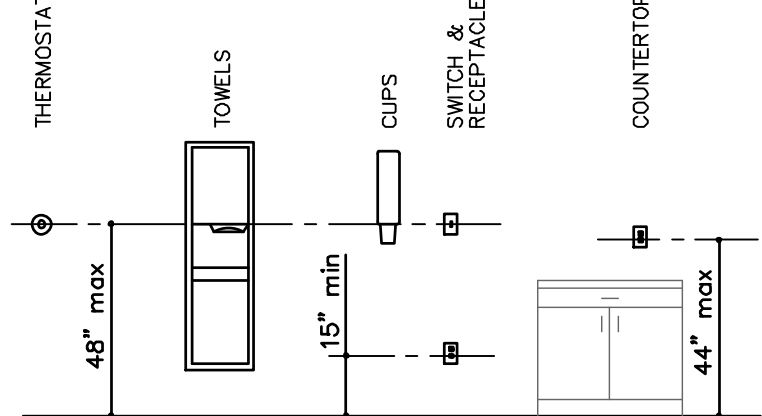

H STANDARD CONTROL REACH LIMITATIONS DETAILS

NO SCALE

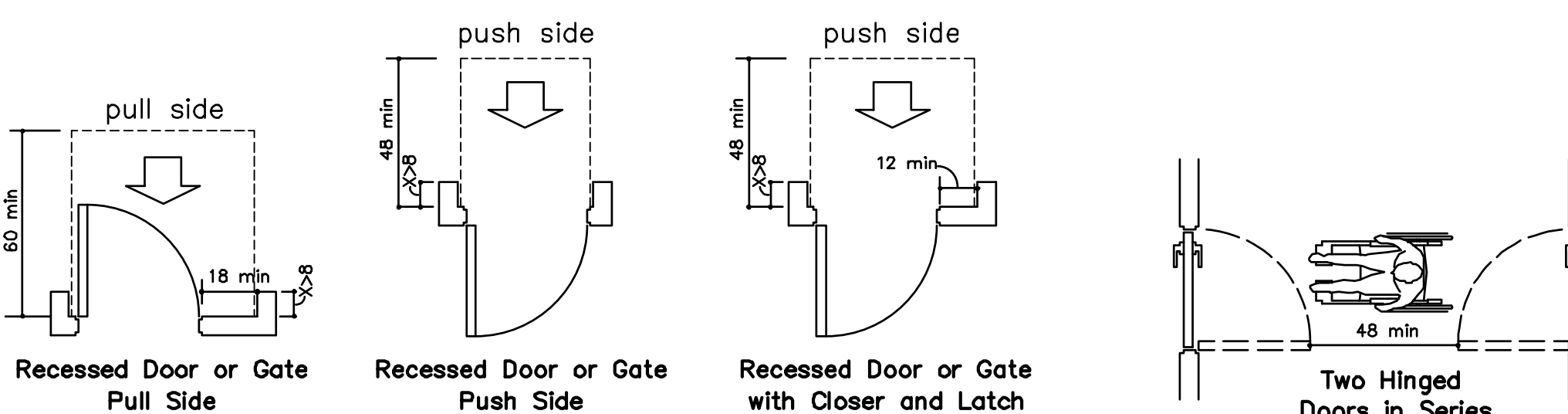

Recessed Door or Gate Pull Side, Push Side, Two Hinged Doors in Series

LANDINGS SHALL COMPLY WITH STANDARD DOOR APPROACH ADA DIAGRAMS AND SHALL NOT HAVE A CROSS SLOPE GREATER THAN 1:50 AND SHALL NOT SLOPE IN THE DIRECTION OF TRAVEL GREATER THAN 1:50.

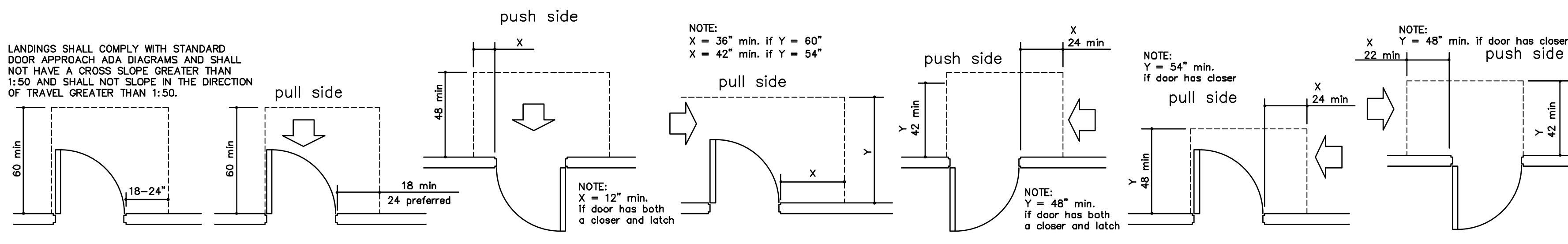

Exterior Landing, Front Approach - Swinging Door, Hinge Side Approach - Swinging Door, Latch Side Approach - Swinging Door, Hinge Side Approach - Sliding or Folding Doors

G STANDARD DOOR APPROACH DIAGRAMS

NO SCALE

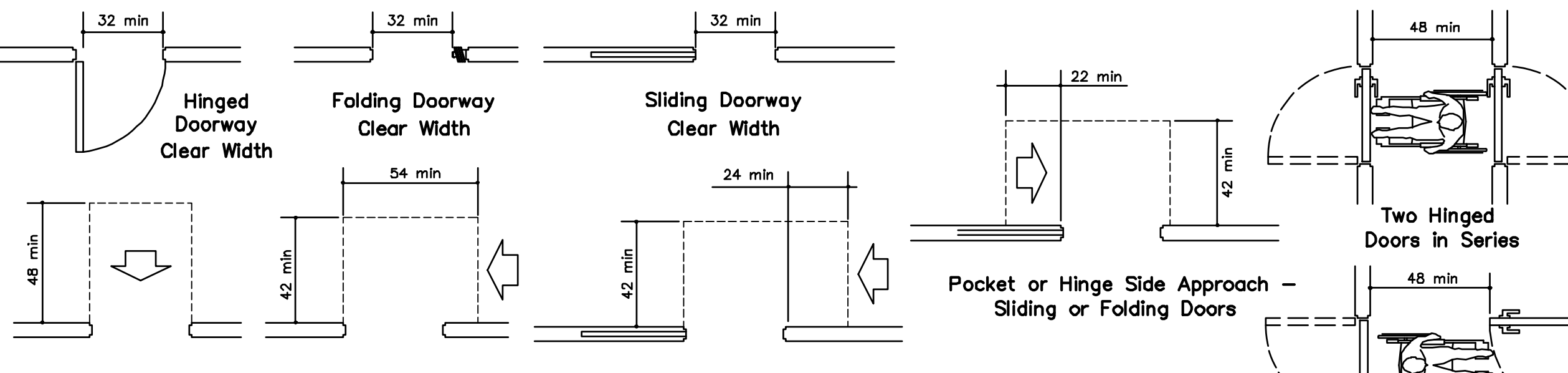

Hinged Doorway Clear Width, Folding Doorway Clear Width, Sliding Doorway Clear Width, Clear Floor Space at Bathtub

E STANDARD BATHROOM/TUB DIAGRAMS

NO SCALE

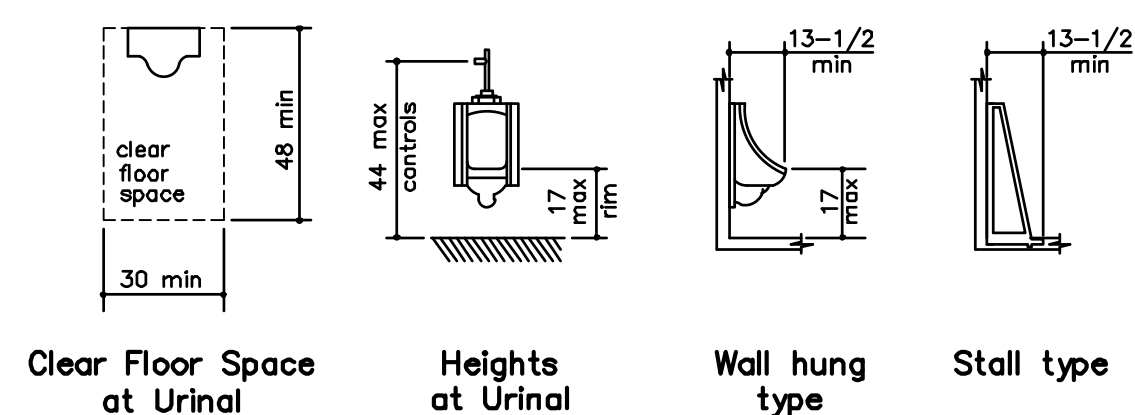

Clear Floor Space at Urinal, Heights at Urinal, Wall hung type, Stall type

F STANDARD URINAL DIAGRAMS

NO SCALE

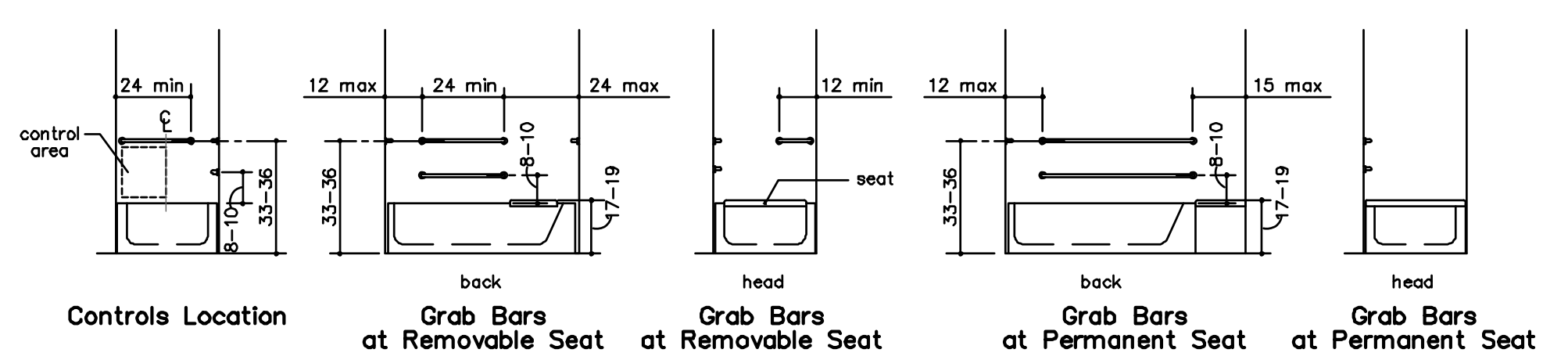

Controls Location, Grab Bars at Removable Seat, Grab Bars at Permanent Seat

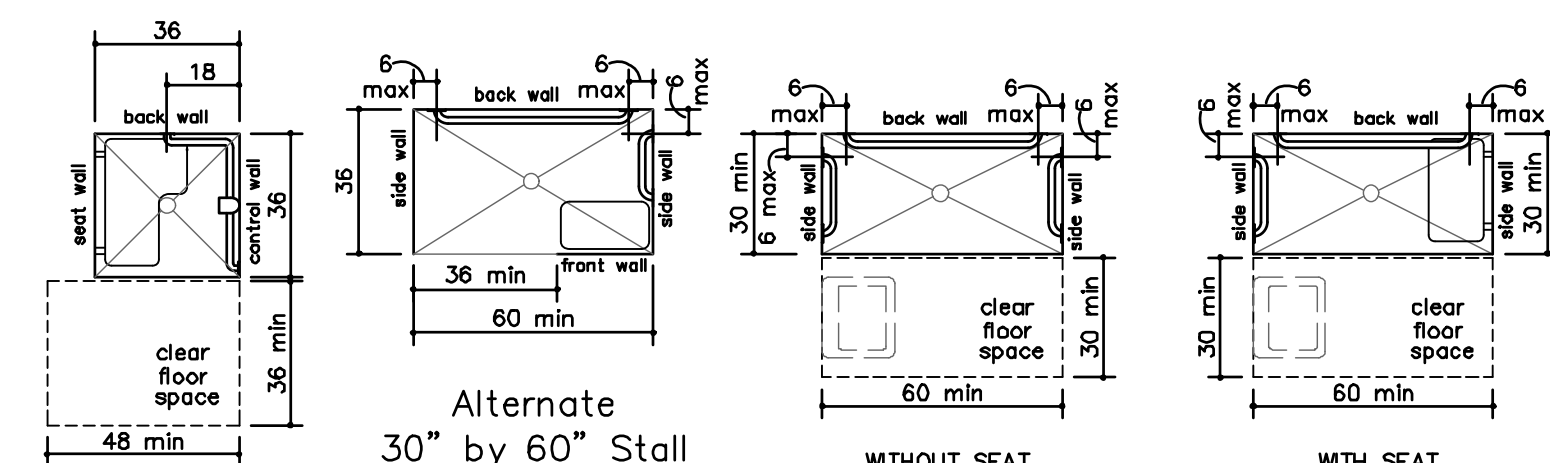

Alternate Roll in Type Shower Compartment, Standard Roll in Type Shower Compartment

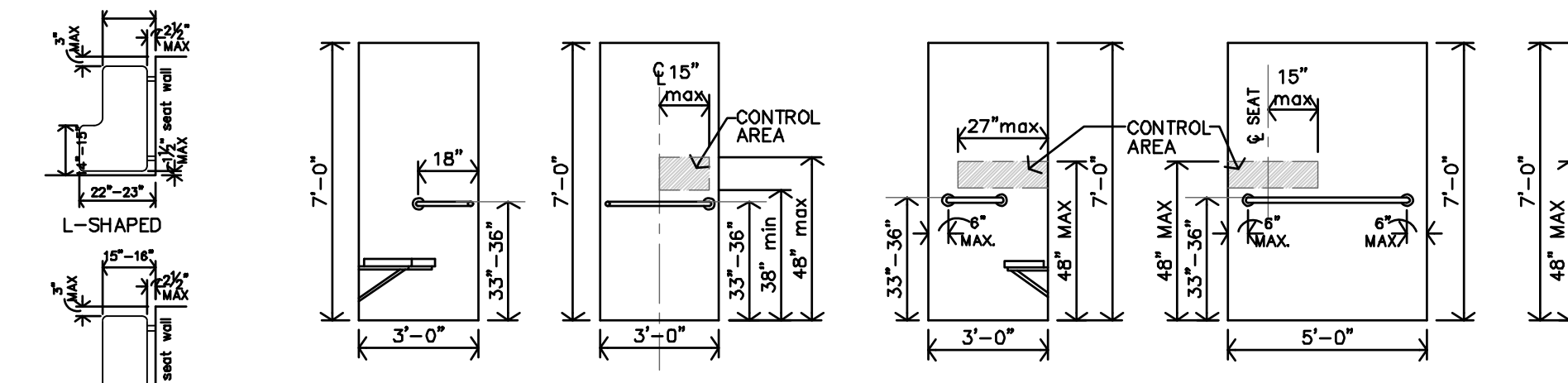

36\"/>

D STANDARD SHOWER DIAGRAMS

NO SCALE

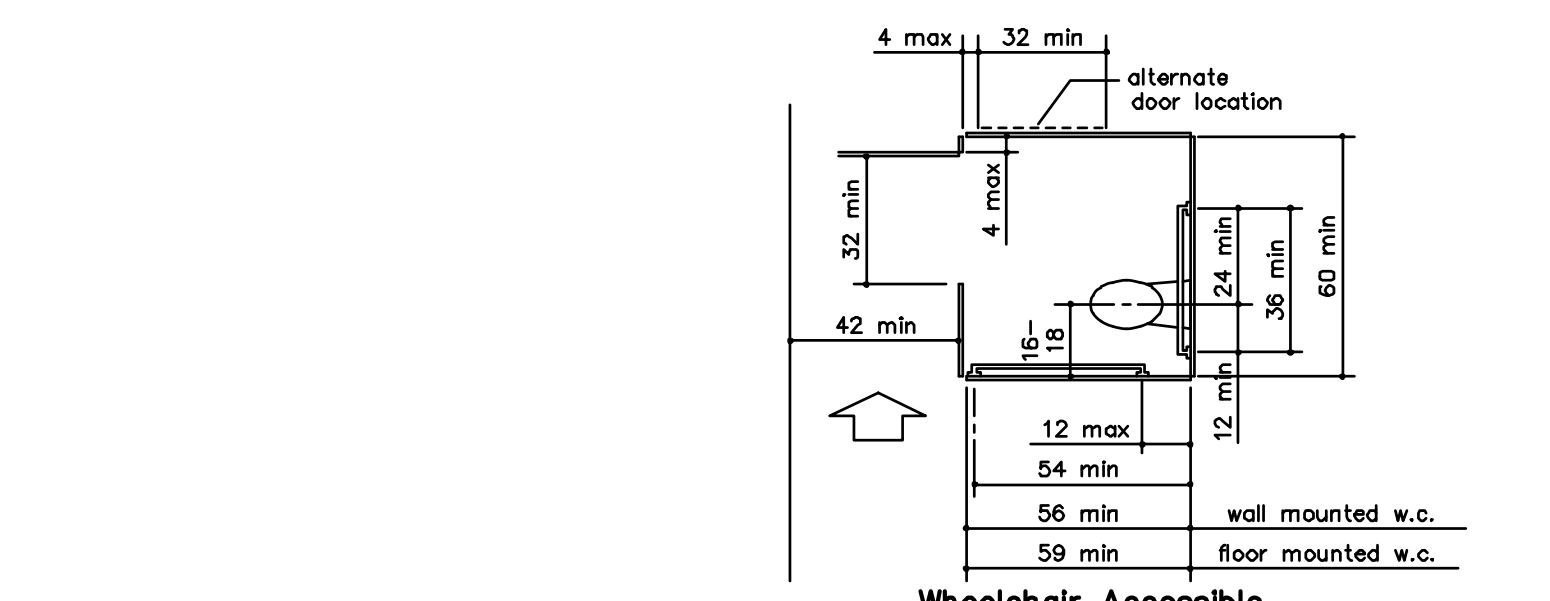

Wheelchair Accessible Toilet Compartment, Ambulatory Accessible Toilet Compartment

B STANDARD TOILET STALL DIAGRAMS

NO SCALE

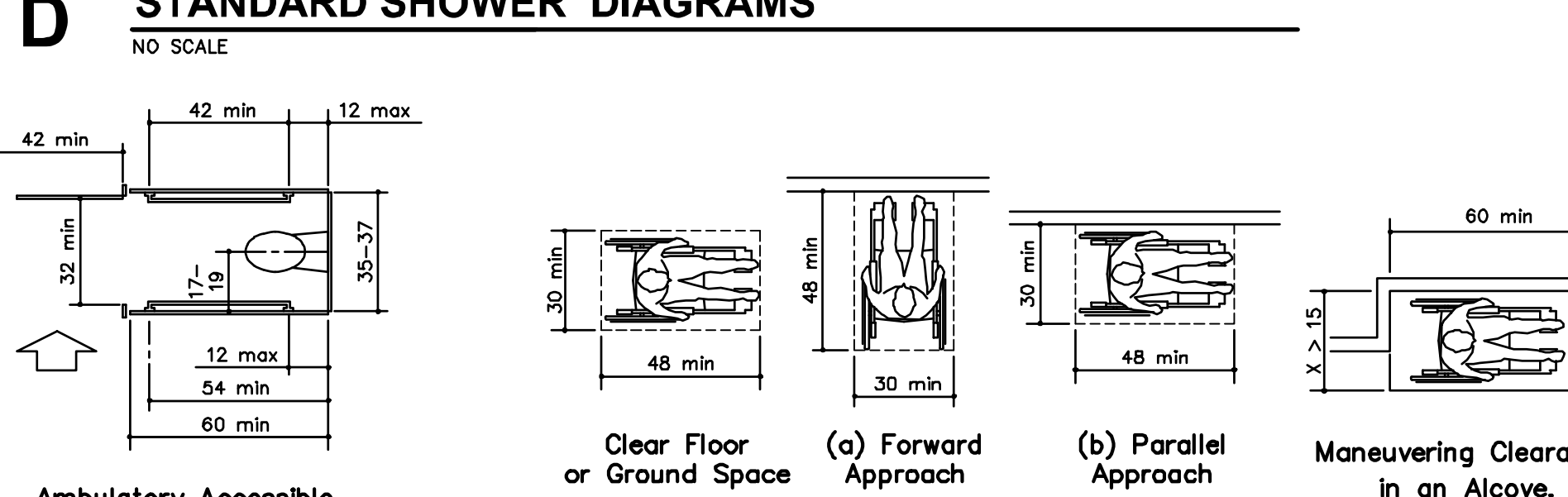

Clear Floor or Ground Space, Forward Approach, Parallel Approach, Maneuvering Clearance in an Alcove

A STANDARD DIAGRAMS

NO SCALE

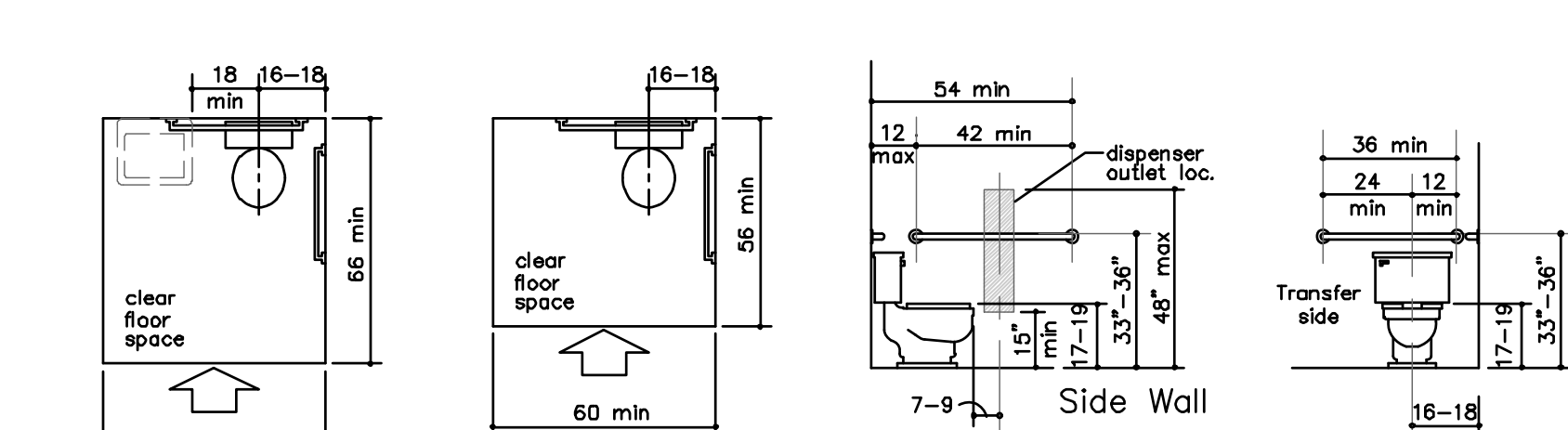

Clear Floor Space at Water Closet, Grab Bars at Water Closets, Back Wall of Standard Stall

C STANDARD TOILET DIAGRAMS

NO SCALE

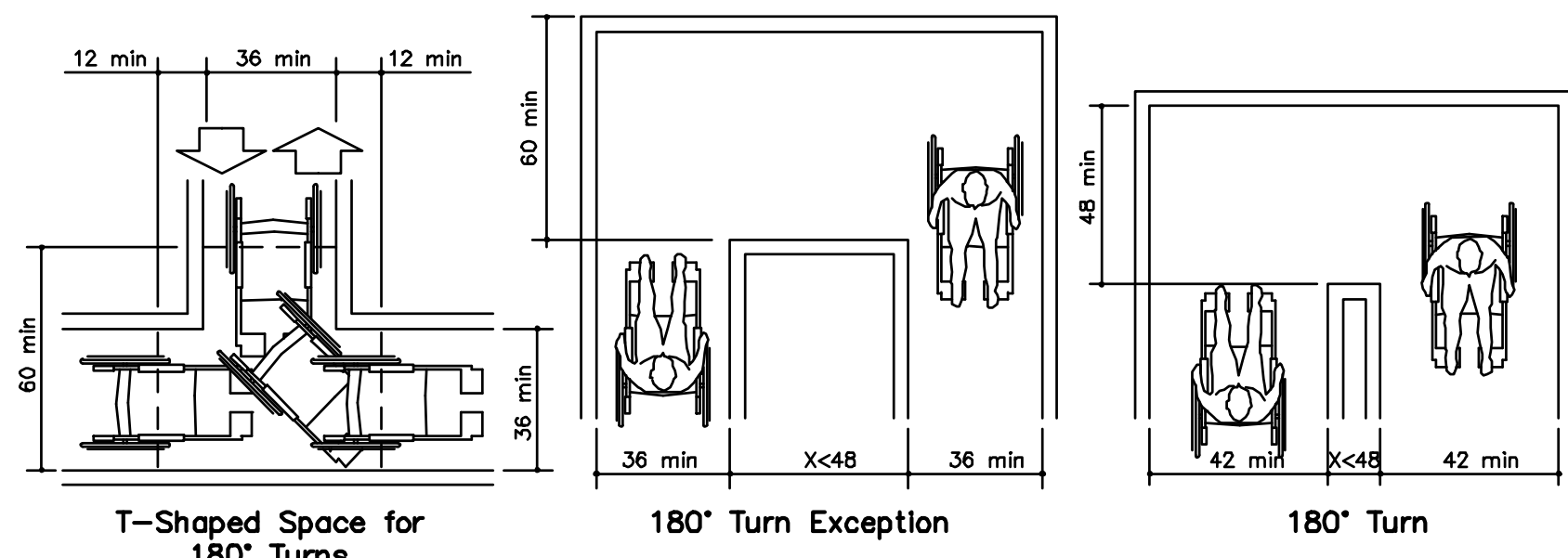

T-Shaped Space for 180° Turns, 180° Turn Exception, 180° Turn

FOR REFERENCE ONLY

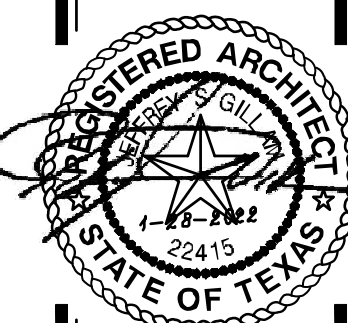

REVISION:	
DATE:	1-28-2022
JOB:	21-3137
SHEET:	

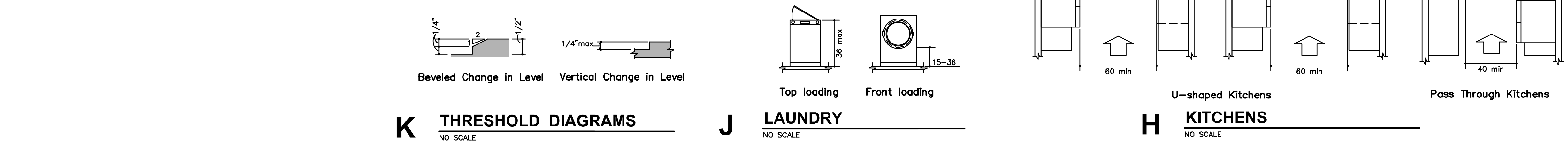

K THRESHOLD DIAGRAMS
NO SCALE

J LAUNDRY
NO SCALE

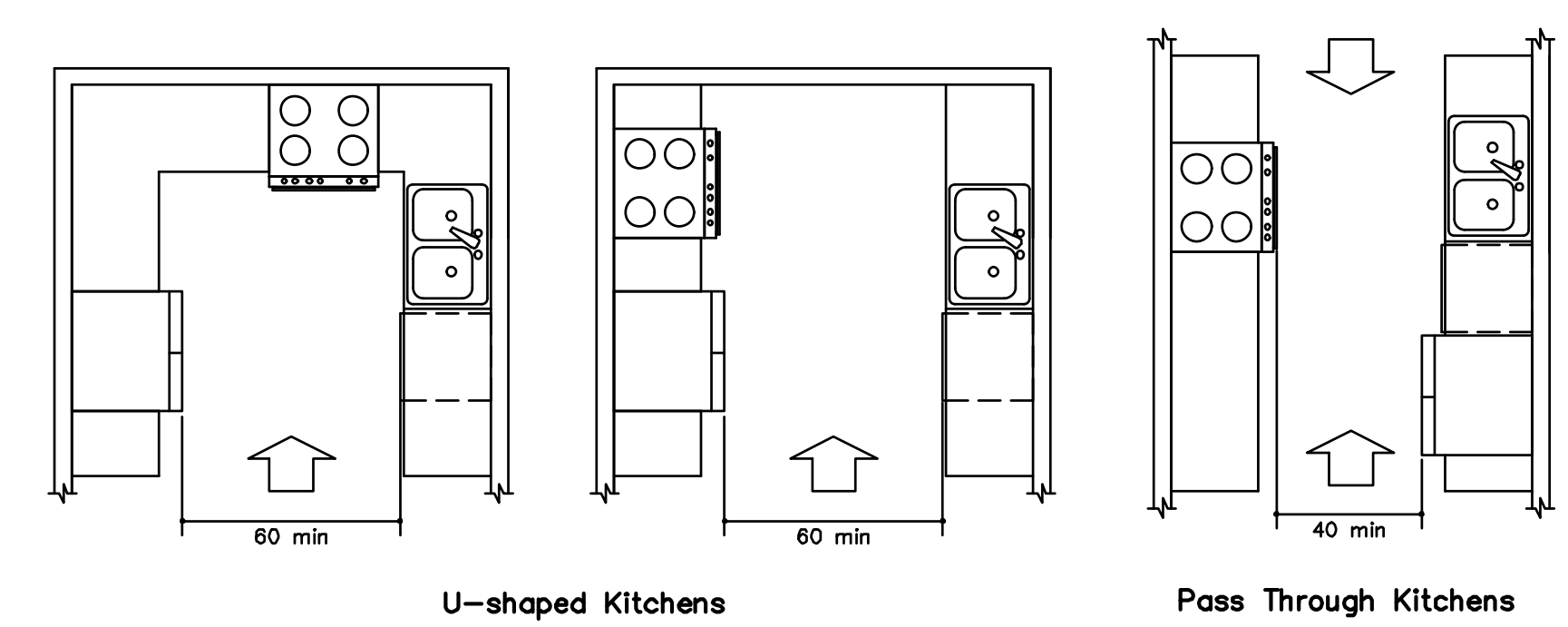

H KITCHENS
NO SCALE

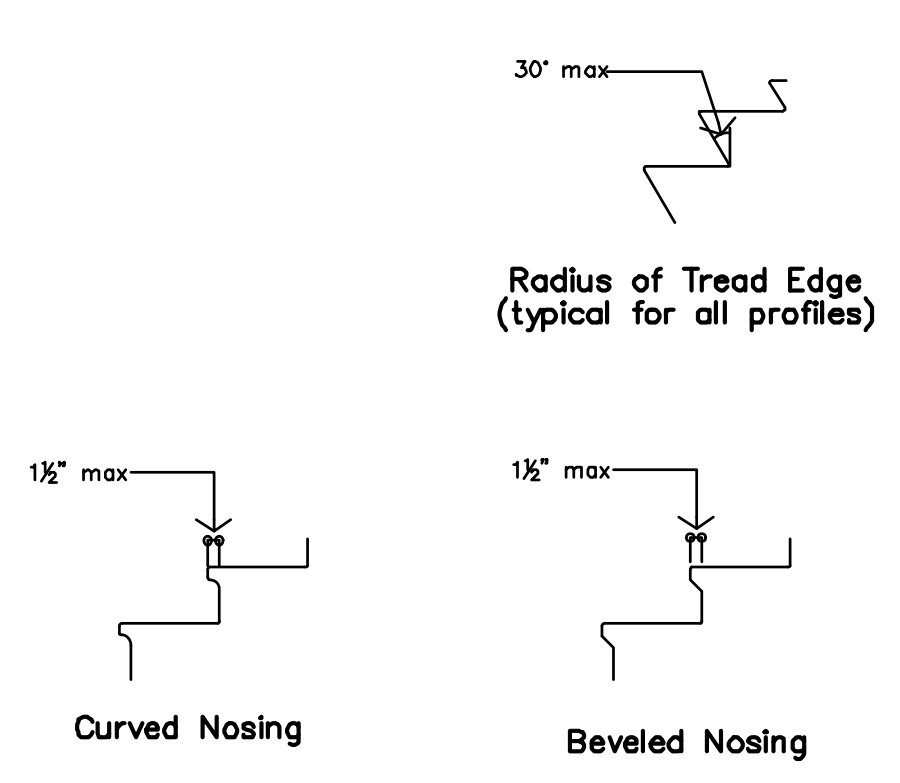

D STANDARD STAIR NOSING DETAILS
NO SCALE

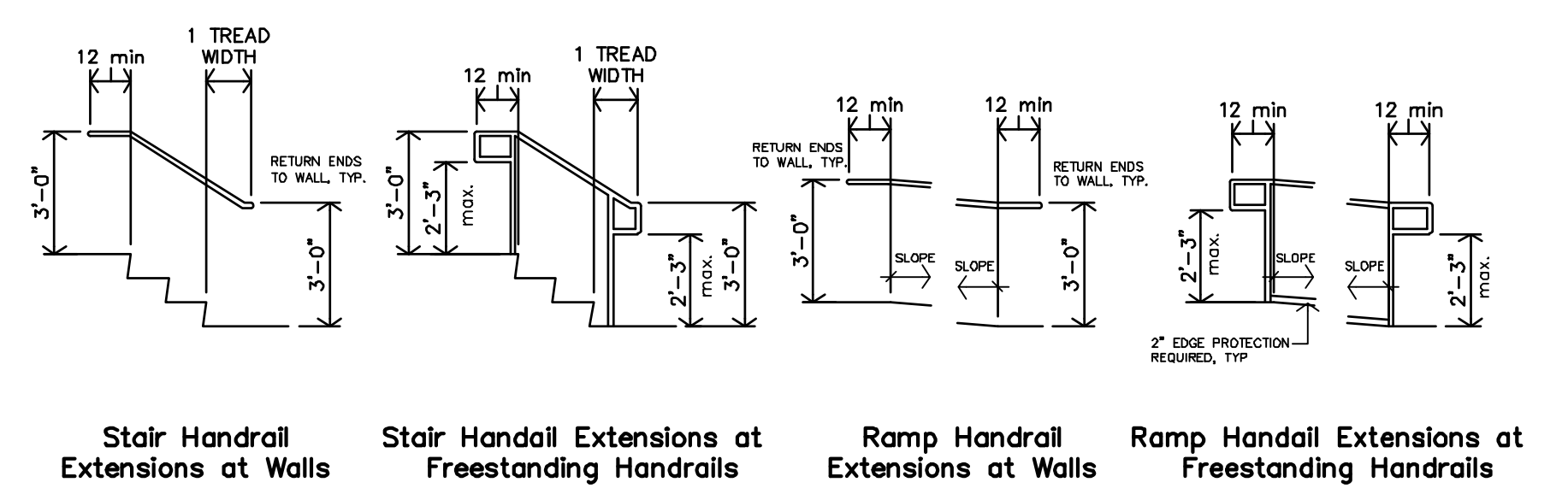

C STANDARD RAMP/STAIR HANDRAIL EXTENSIONS
NO SCALE

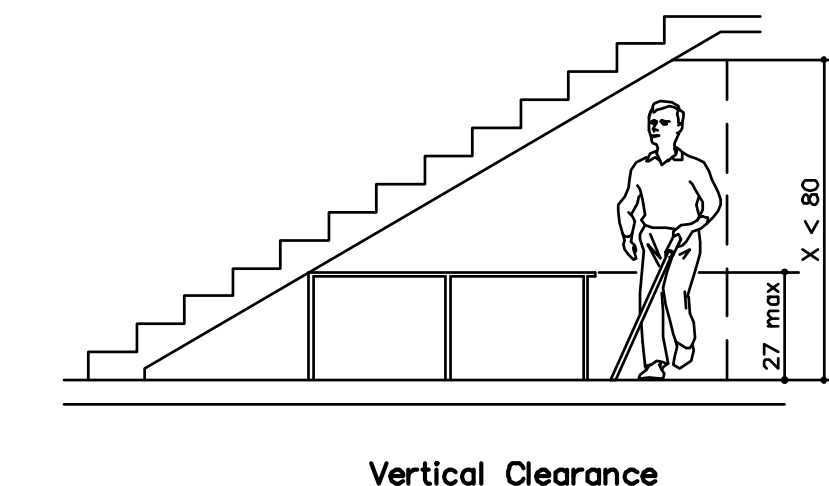

G STANDARD VERTICAL CLEARANCE
NO SCALE

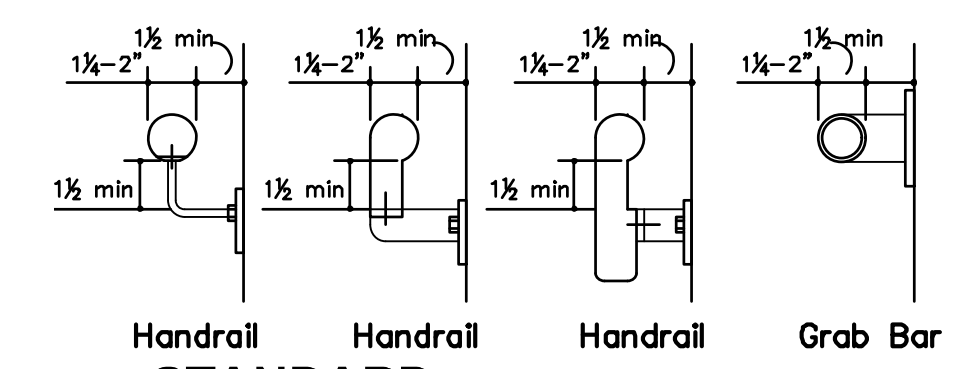

F STANDARD HANDRAIL/GRAB BAR DETAILS
NO SCALE

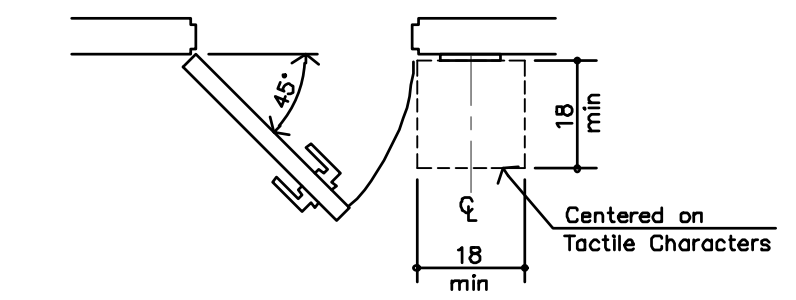

E TACTILE SIGN DIAGRAM
NO SCALE

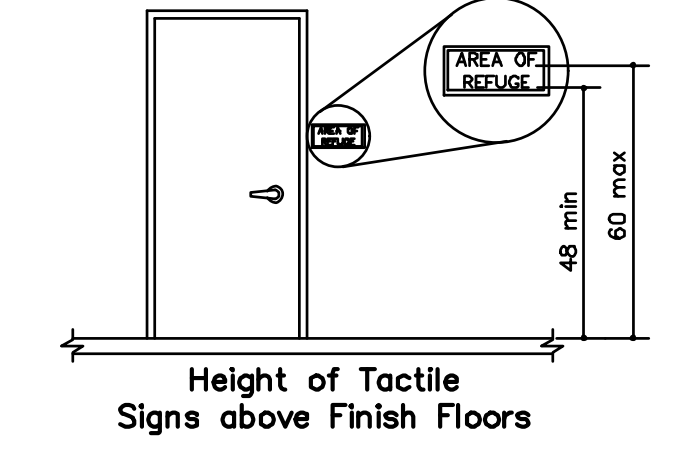

E TACTILE SIGN DIAGRAM
NO SCALE

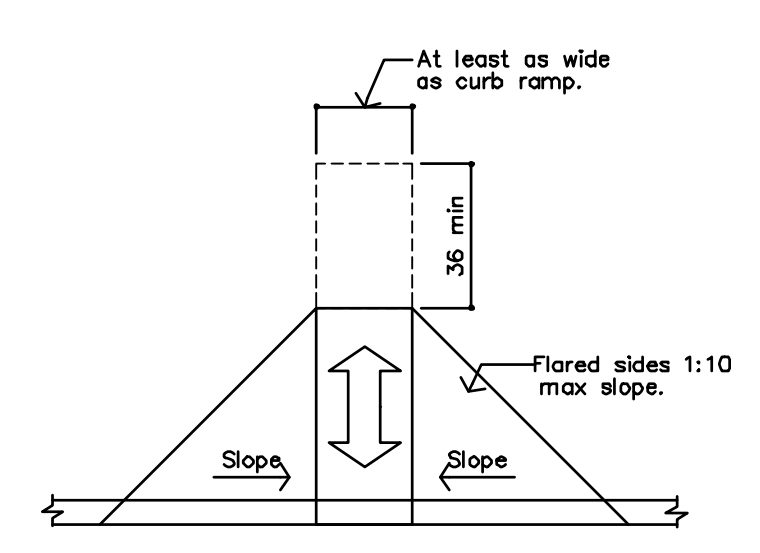

B STANDARD CURB RAMPS DIAGRAMS
NO SCALE

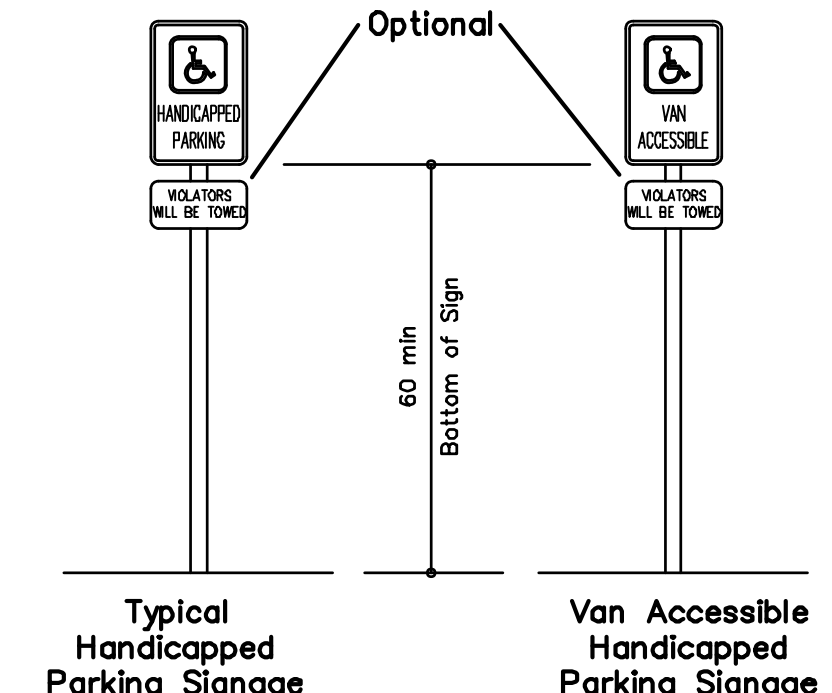
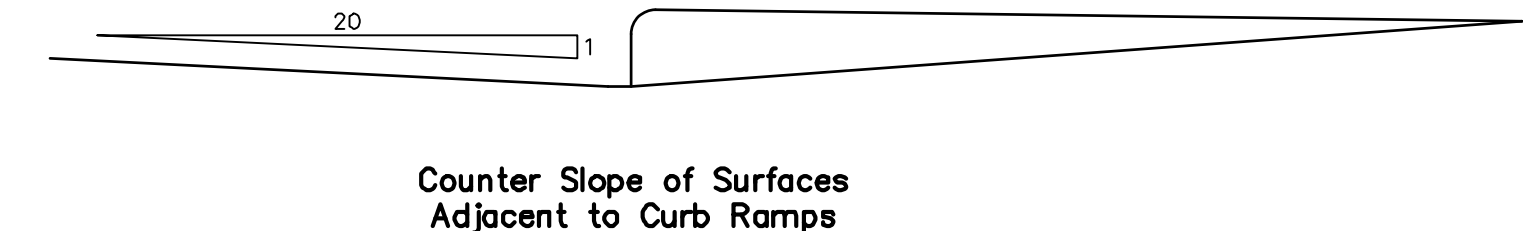

A STANDARD PARKING DIAGRAMS
NO SCALE

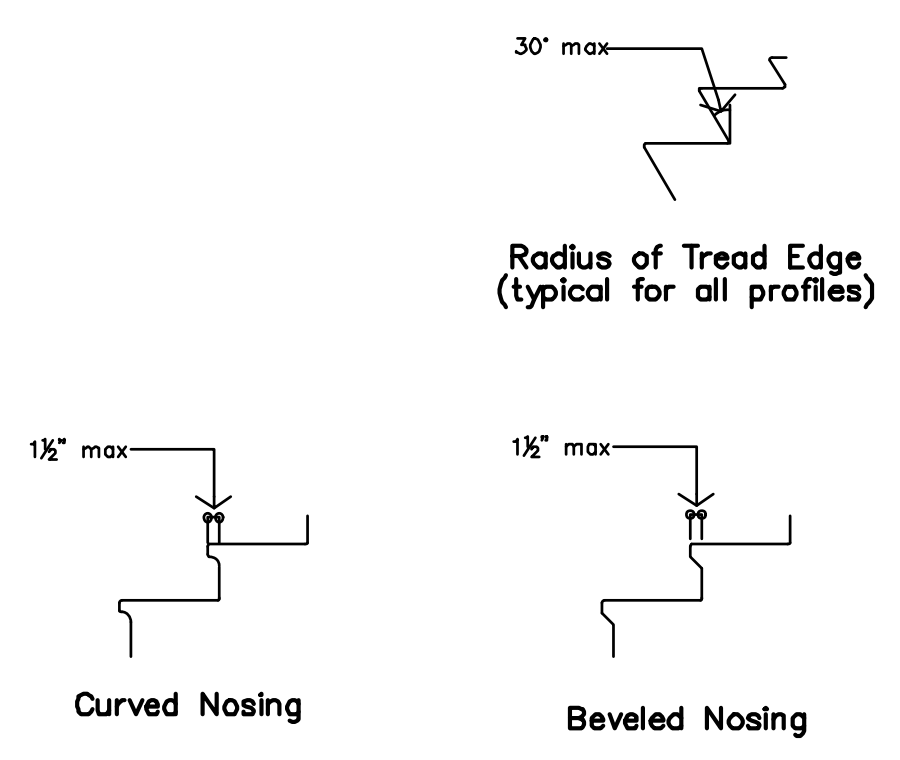
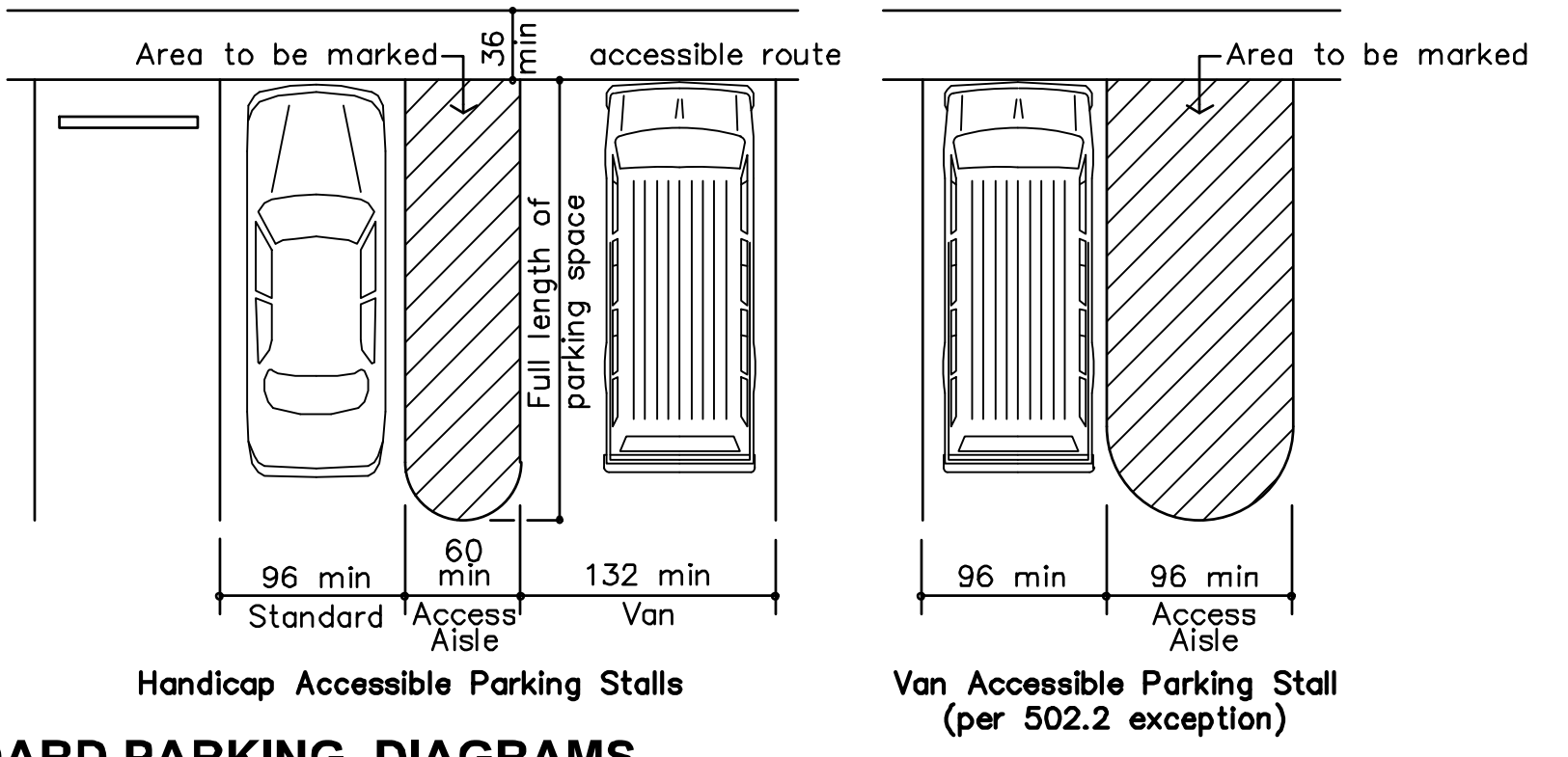

D STANDARD STAIR NOSING DETAILS
NO SCALE

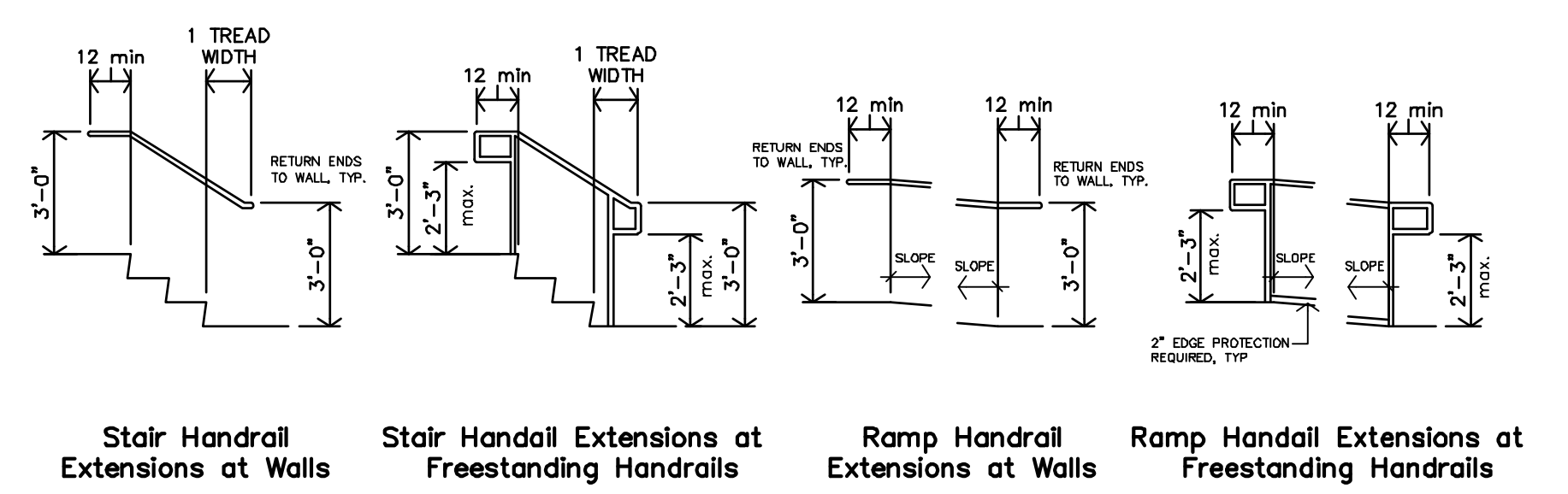

C STANDARD RAMP/STAIR HANDRAIL EXTENSIONS
NO SCALE

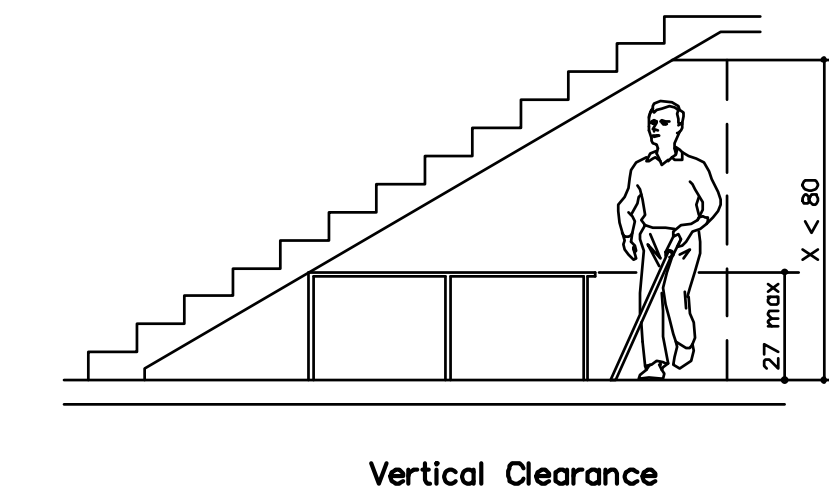

G STANDARD VERTICAL CLEARANCE
NO SCALE

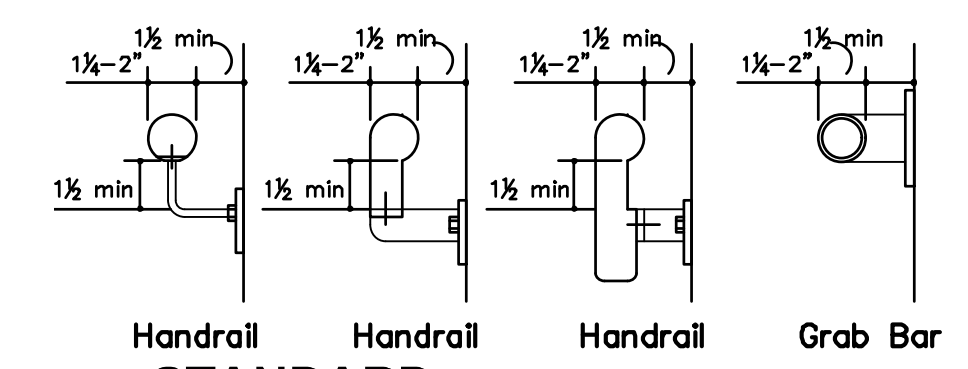

F STANDARD HANDRAIL/GRAB BAR DETAILS
NO SCALE

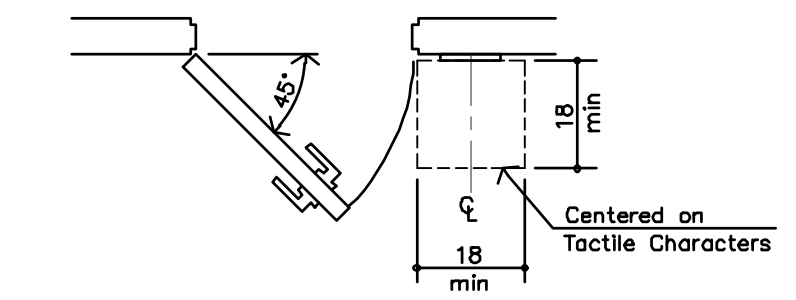

E TACTILE SIGN DIAGRAM
NO SCALE

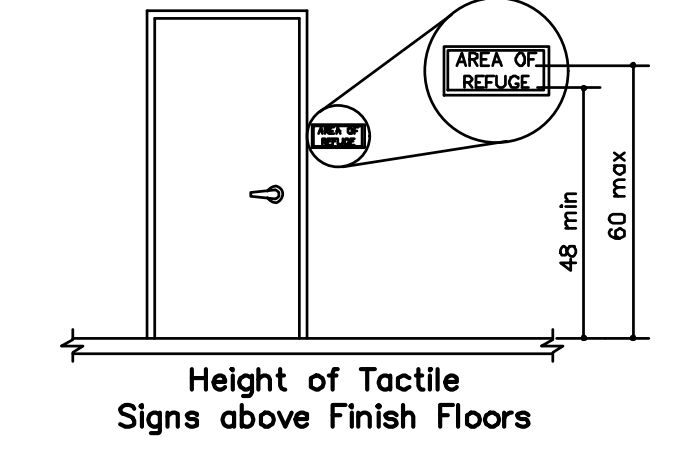

E TACTILE SIGN DIAGRAM
NO SCALE

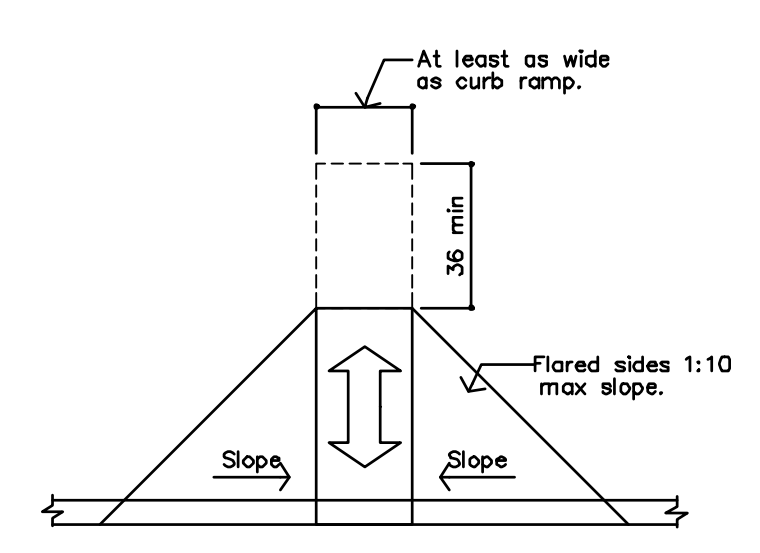

B STANDARD CURB RAMPS DIAGRAMS
NO SCALE

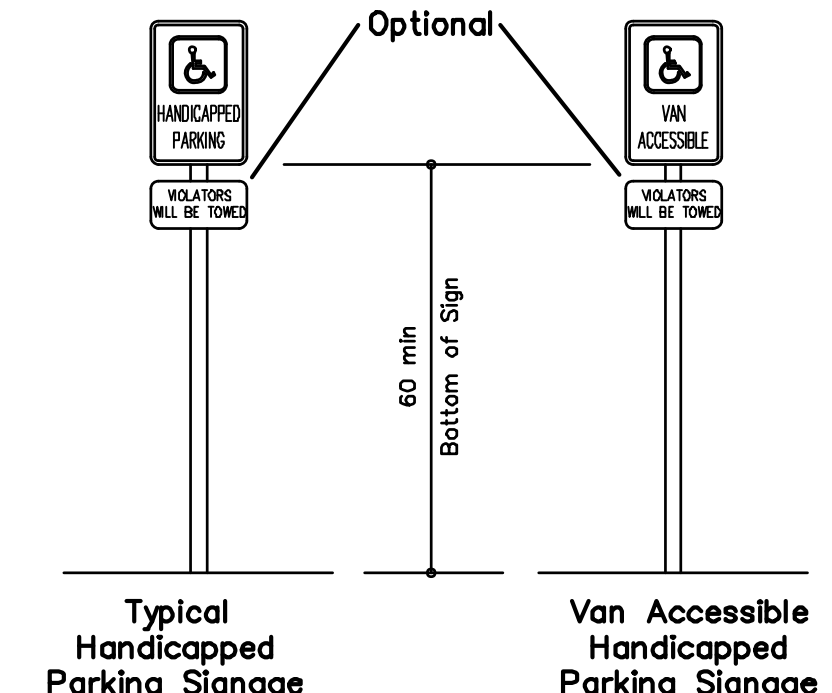
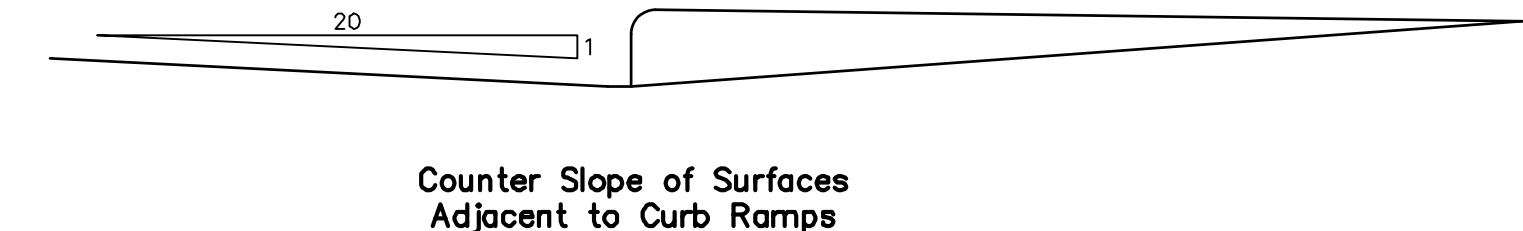

A STANDARD PARKING DIAGRAMS
NO SCALE

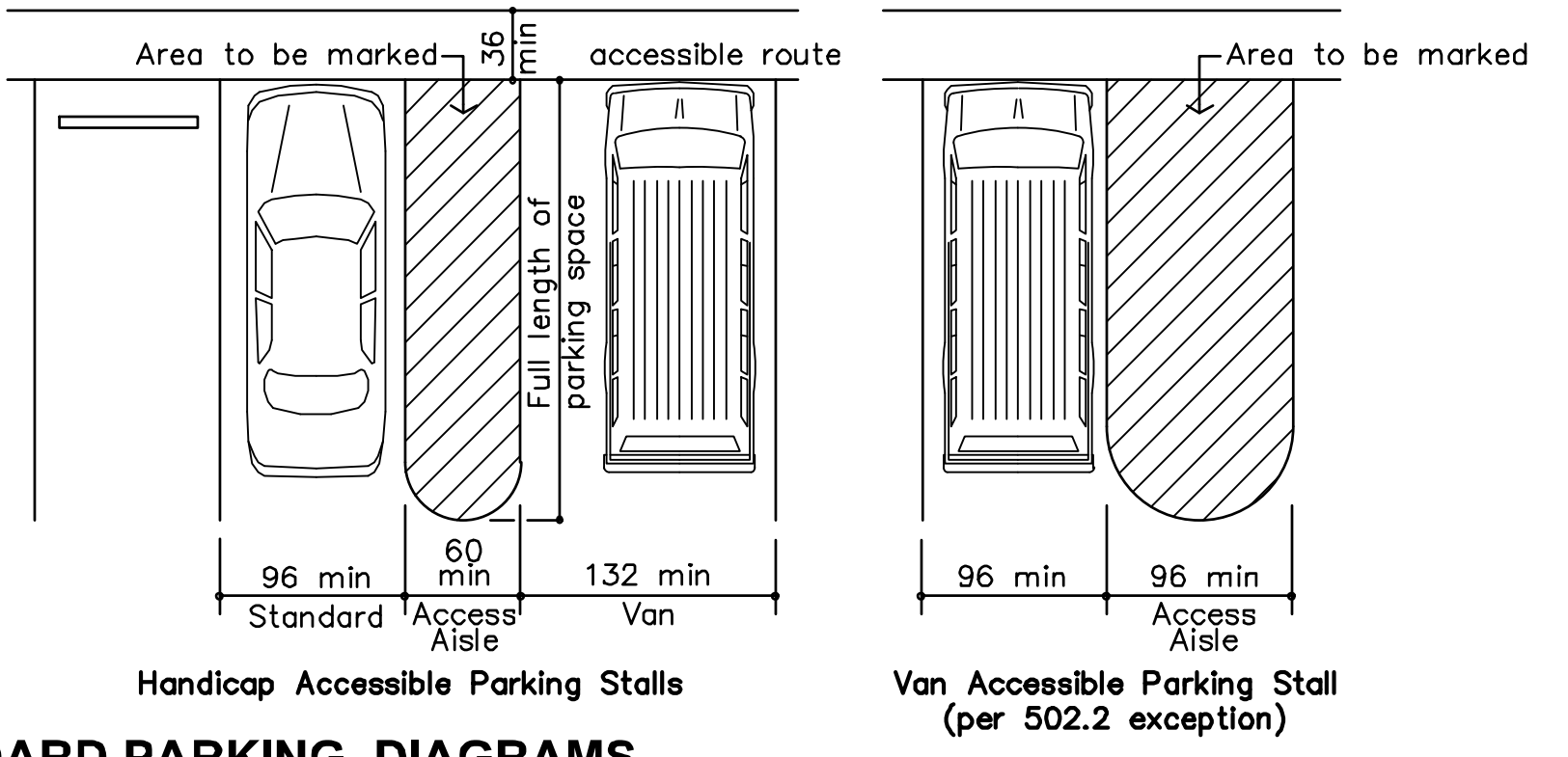

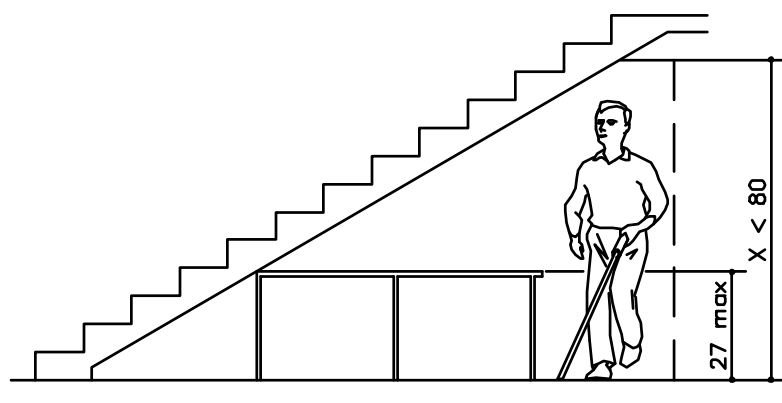

Vertical Clearance

S STANDARD VERTICAL CLEARANCE

NO SCALE

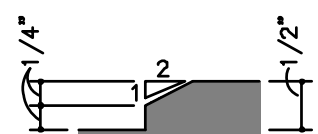

Beveled Change in Level

P THRESHOLD ADA DIAGRAMS

NO SCALE

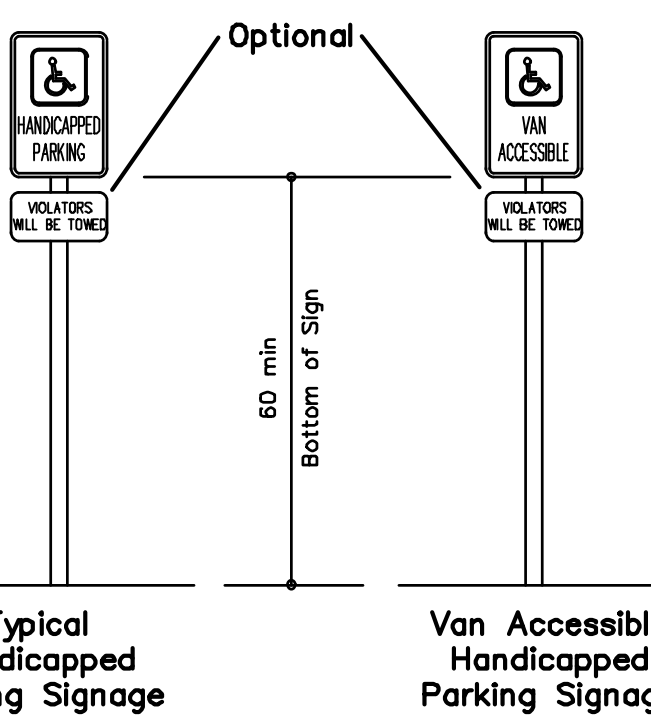

Typical Handicapped Parking Signage
Van Accessible Handicapped Parking Signage

L STANDARD PARKING ADA DIAGRAMS

NO SCALE

LANDINGS SHALL COMPLY WITH STANDARD DOOR APPROACH ADA DIAGRAMS AND SHALL NOT HAVE A CROSS SLOPE GREATER THAN 1:50 AND SHALL NOT SLOPE IN THE DIRECTION OF TRAVEL GREATER THAN 1:50.

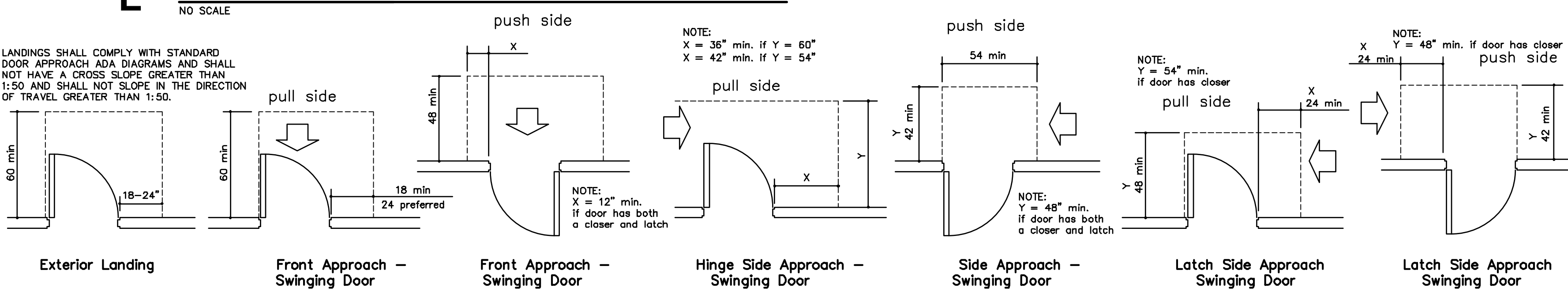

Exterior Landing
Front Approach - Swinging Door
Front Approach - Swinging Door
Hinge Side Approach - Swinging Door
Side Approach - Swinging Door
Latch Side Approach Swinging Door
Latch Side Approach Swinging Door
Front Approach - Sliding or Folding Doors
Side Approach - Sliding or Folding Doors
Stop or Latch Side Approach - Sliding or Folding Doors

F TACTILE SIGN DIAGRAM

NO SCALE

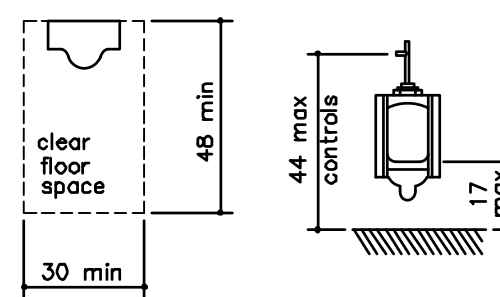

Clear Floor Space at Urinal
Heights at Urinal

C STANDARD URINAL ADA DIAGRAMS

NO SCALE

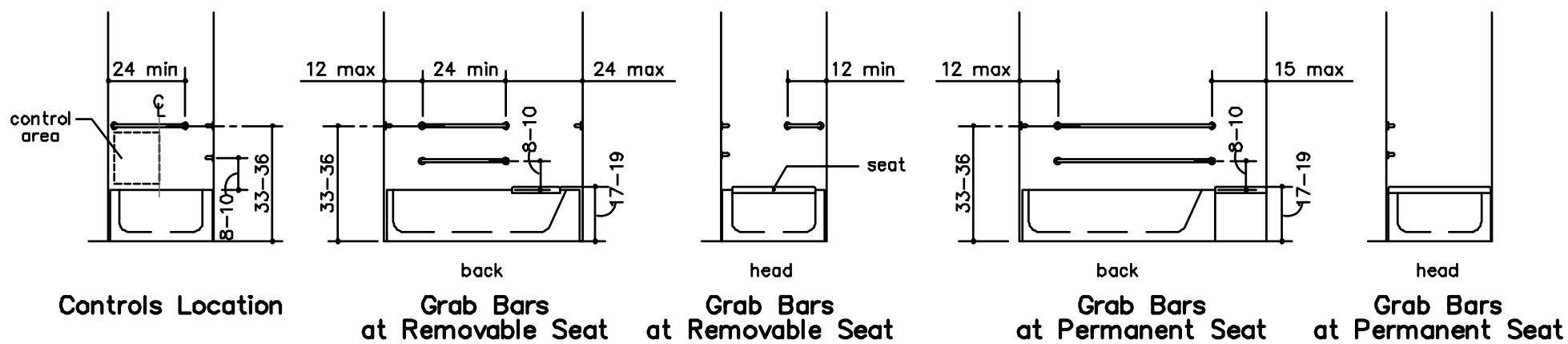

Controls Location
Grab Bars at Removable Seat
Grab Bars at Removable Seat
Grab Bars at Permanent Seat
Grab Bars at Permanent Seat

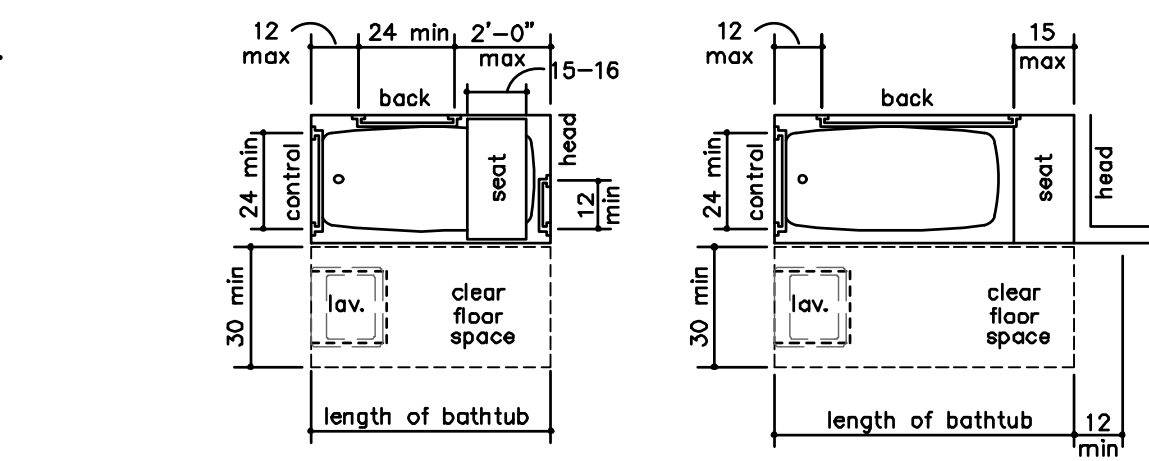

Clear Floor Space at Bathtub With Removable Seat
Clear Floor Space at Bathtub With Permanent Seat

O STANDARD BATHROOM/TUB ADA DIAGRAMS

NO SCALE

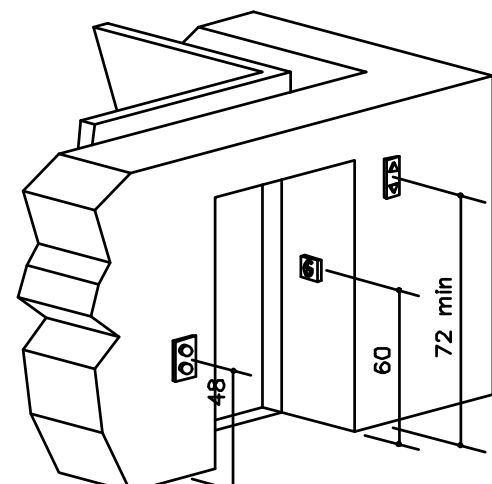

Hoistway and Elevator Entrances

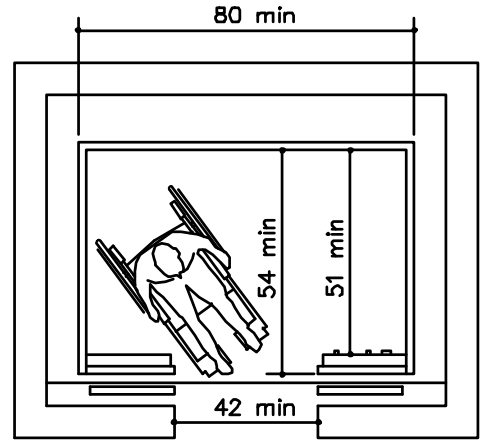

Minimum Dimensions for Elevator Car

N STANDARD ELEVATOR ADA DIAGRAMS

NO SCALE

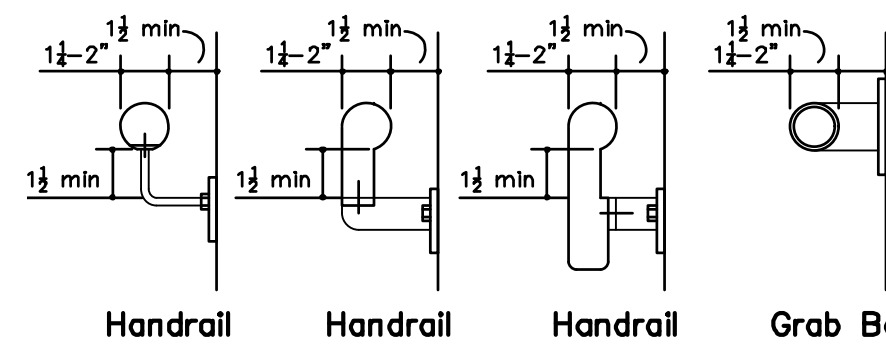

Handrail
Handrail
Handrail
Grab Bar

K STANDARD HANDRAIL/GRAB BAR DETAILS

NO SCALE



R STANDARD REACH ADA DIAGRAMS

NO SCALE

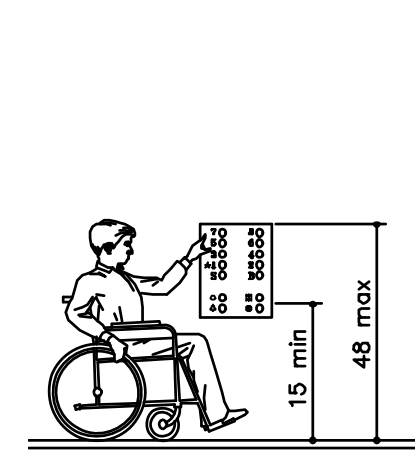

Car Control Height

J STANDARD DRINKING FOUNTAIN DETAILS

NO SCALE

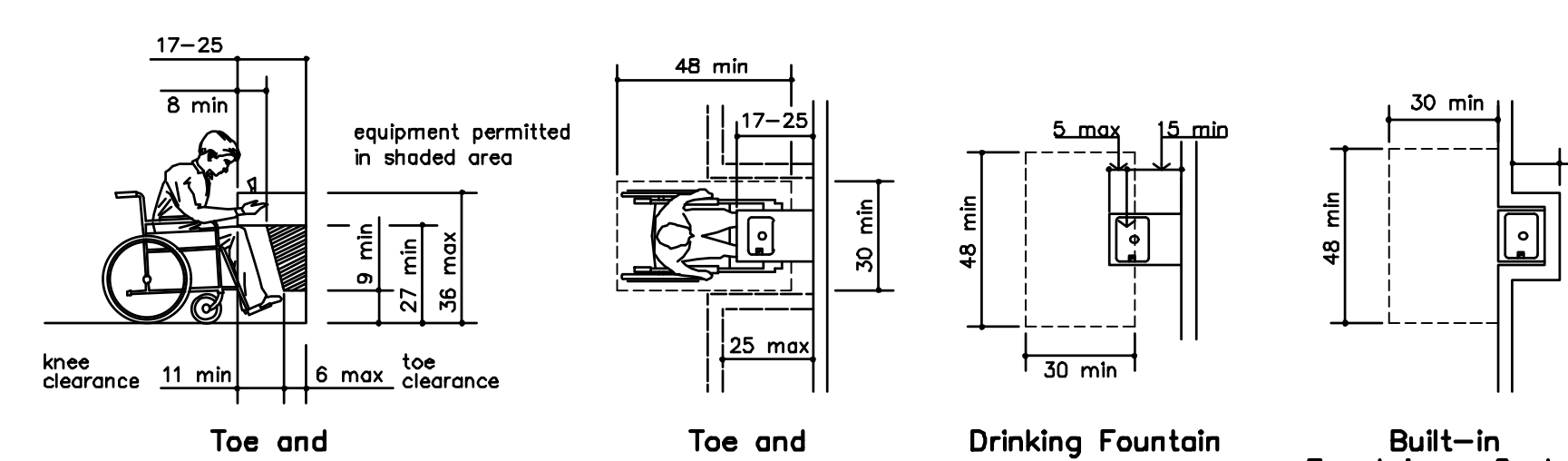

Toe and Knee Clearance Elevation
Toe and Knee Clearance Plan
Drinking Fountain Spout Location
Built-in Fountain or Cooler

H STANDARD LAVATORY DETAILS

NO SCALE

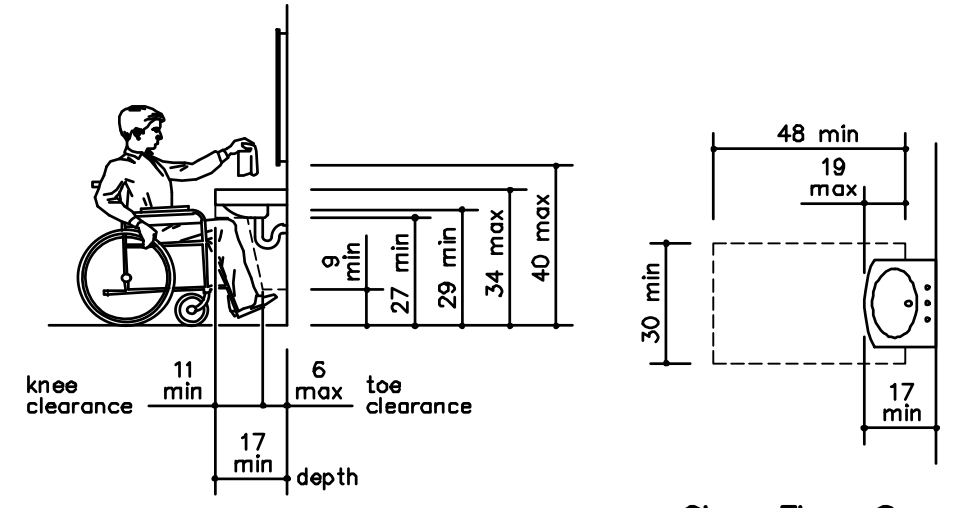

Lavatory Clearances at Lavatories
Clear Floor Space at Lavatories

G STANDARD DOOR APPROACH ADA DIAGRAMS

NO SCALE

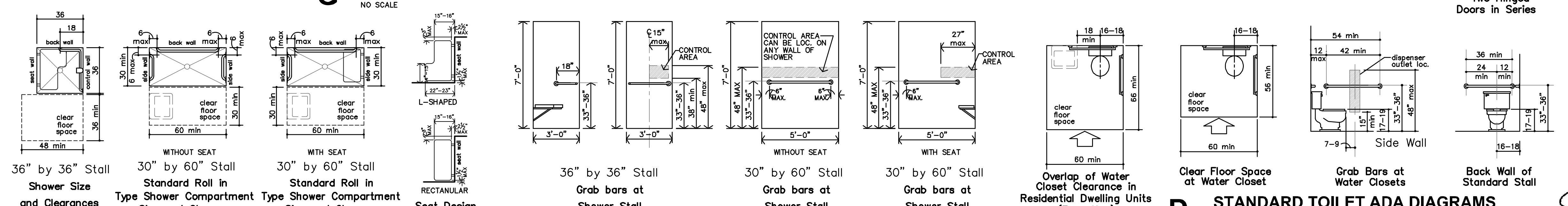

36" by 36" Stall Shower Size and Clearances
30" by 60" Stall Standard Roll in Type Shower Compartment Size and Clearance
30" by 60" Stall Standard Roll in Type Shower Compartment Size and Clearance
Seat Design
36" by 36" Stall Grab bars at Shower Stall
30" by 60" Stall Grab bars at Shower Stall
30" by 60" Stall Grab bars at Shower Stall
Overlap of Water Closet Clearance in Residential Dwelling Units (Exception)
Clear Floor Space at Water Closet
Grab Bars at Water Closets
Back Wall of Standard Stall

E STANDARD SHOWER ADA DIAGRAMS

NO SCALE

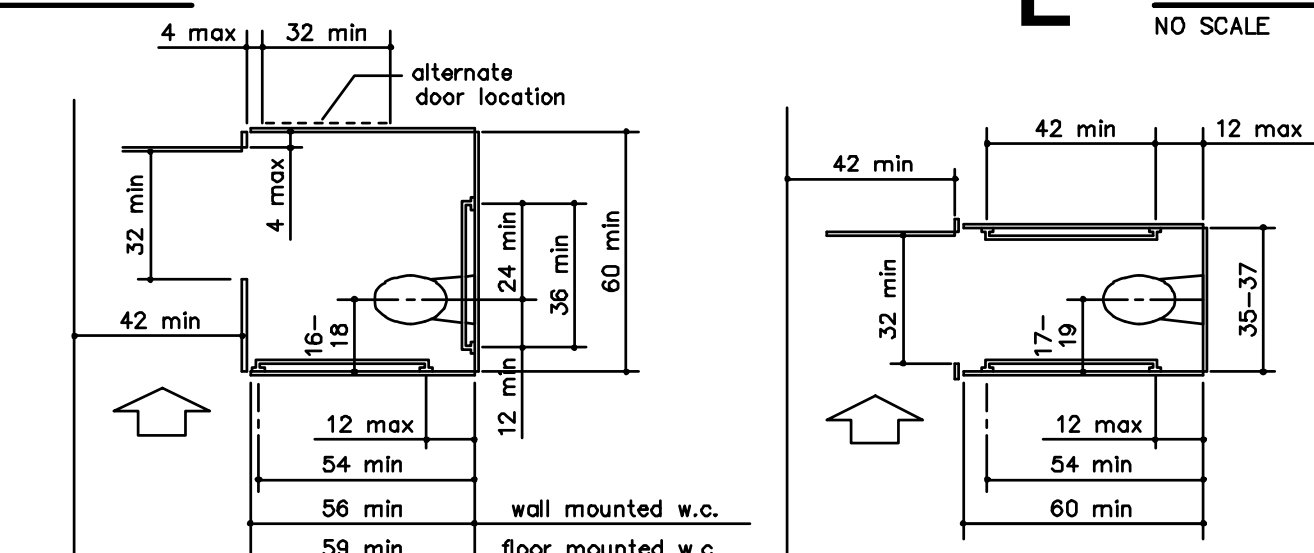

Wheelchair Accessible Toilet Compartment
Ambulatory Accessible Toilet Compartment

B STANDARD TOILET STALL ADA DIAGRAMS

NO SCALE

A STANDARD ADA DIAGRAMS

NO SCALE

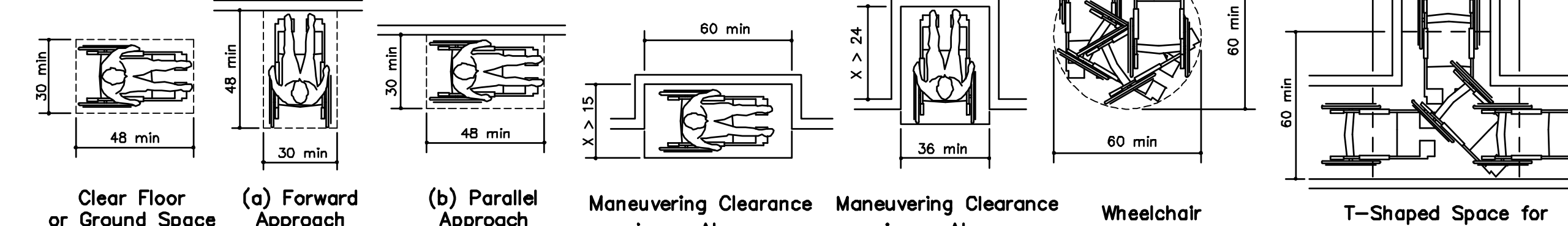

Clear Floor or Ground Space
(a) Forward Approach
(b) Parallel Approach
Maneuvering Clearance in an Alcove, Parallel Approach
Maneuvering Clearance in an Alcove, Forward Approach
Wheelchair Turning Space
T-Shaped Space for 180° Turns

Q STANDARD CONTROL REACH LIMITATIONS DETAILS

NO SCALE

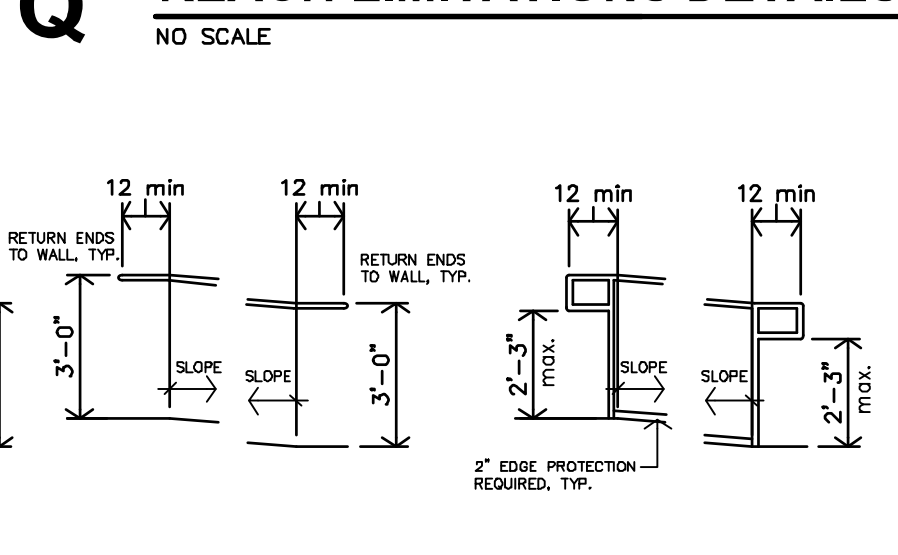

M STANDARD RAMP/STAIR HANDRAIL EXTENSIONS

NO SCALE

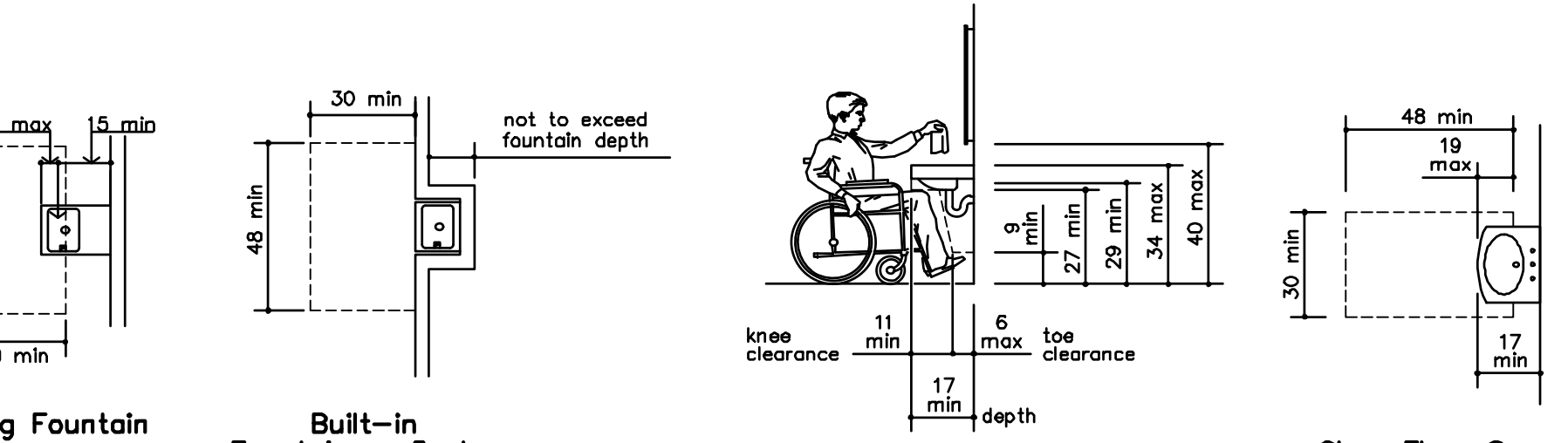

Stair Handrail Extensions at Walls
Stair Handrail Extensions at Freestanding Handrails
Ramp Handrail Extensions at Walls
Ramp Handrail Extensions at Freestanding Handrails

SITE PLAN KEY NOTES

(A)	CONDENSING UNITS - REF. MECHANICAL DRAWINGS
(B)	KNOX BOX COORD. W/ FIRE DEPT. (TYP)
(C)	MECH. CLOSET REF. & COORDINATE W/ M/E DRAWINGS (TYP)
(D)	ACCESSIBLE TRASH ENCLOSURE REF. SHEET A1.2
(E)	DASHED LINE INDICATES ACCESSIBLE PATH
(F)	NEW POLE MOUNTED H.C. PARKING SIGN MOUNT BTM. OF SIGN @ 60" A.F.F. (TYP)
(G)	NEW POLE MOUNTED H.C. "VAN" PARKING SIGN MOUNT BTM. OF SIGN @ 60" A.F.F. (TYP)
(H)	BIKE RACK, REF SHEET A1.2
(J)	PAINTED STRIPPING @ ACCESSIBLE ROUTE
(K)	ELECTRIC METERS & TRANSFORMER - REF. ELECT. DRAWINGS

GENERAL SITE PLAN NOTES

1. GENERAL CONTRACTOR SHALL FIELD VERIFY ALL EXISTING CONDITIONS & DIMENSIONS.
2. INSTALL MATERIALS AND FINISHES AS INDICATED, IMPLIED OR AS REQUIRED FOR FINISH INSTALLATION.
3. WHERE NEW CONCRETE ADJUTS THE BUILDING, PROVIDE 3/4" EXPANSION JOINT & SEAL TOP WITH EPOXY SEALER.
4. INSTALL EXPANSION JOINTS IN CONCRETE SIDEWALK PAVING AT ±60" O.C. PROVIDE FILLER MATERIAL AND SEALANT. COORDINATE WITH ARCHITECT FOR FINAL LOCATIONS OF EXPANSION JOINTS.
5. INSTALL CONTROL JOINTS IN CONCRETE ROUGHLY SQUARE AND AREAS NOT TO EXCEED 100 S.F.
6. EXTERIOR DOOR LANDINGS SHALL BE WITHIN 3" OF INTERIOR FINISH FLOOR ELEVATION. MAXIMUM SLOPE IN ANY DIRECTION SHALL BE 1:50.
7. FINISH FLOOR ELEVATION SHALL BE VERIFIED BY GENERAL CONTRACTOR AND CONFIRMED W/ PROPOSED GRADING TO PROVIDE DRAINAGE AWAY FROM THE BUILDING.
8. LANDSCAPING, SEEDING, PLANTINGS, ETC. TO BE BY OTHERS. ALL AREAS AROUND THE SITE AND AS INDICATED ON THE SITE PLAN SHALL BE FINE GRADED WITH MIN. 2" TOP SOIL. AREAS SHALL BE FREE OF ROCKS AND CLUMPS AS SUITABLE FOR SEEDING OR SODDING.
9. NEW PEDESTRIAN SIDEWALKS SHALL NOT HAVE A CROSS SLOPE GREATER THAN 1:50 AND SHALL NOT SLOPE IN THE DIRECTION OF TRAVEL GREATER THAN 1:20.
10. CONTRACTOR SHALL COORDINATE ALL WORK WITH THE REQUIREMENTS OF THE UTILITY COMPANIES AND THE CITY OF FT. WORTH.
11. REF. SHEETS A2.1, A2.2, A2.3, & A2.4 FOR LOCATION OF ACCESSIBLE (UNITS 1A, 2A & 3A) & HEARING IMPAIRED UNIT (UNIT 1B & 2B).
12. DO NOT CONSTRUCT ANY PART OF THE TRASH PAD, ENCLOSURE AND/OR ACCESS TO, TILL AFTER CONFIRMATION AND COORDINATION OF LOCAL TRASH SERVICE. DUE TO DIFFERENT TRASH COMPANIES, TRUCKS AND PICK-UP PROCESSES, CONFIRMATION OF THE TRASH SERVICE AND COORDINATION OF THE DESIGN AND LAYOUT OF THE PAD, ENCLOSURE AND ACCESS MUST BE COMPLETED.

PARKING SUMMARY

	HAVE	REQ. / ZONING
HANDICAP PARKING STALLS	11	11
STANDARD PARKING STALLS	124	124
COMMONS AREA STALLS	12	12
TOTAL PARKING STALLS	147	147
PARKING RATIO (UNITS/STALLS)	.75	1/250SF COMMON SPACE

Calculations: (180 Bedrooms x .75 = 135) + (2,890sf Office & Commons/250sf = 11.56) = 147 Total Spaces

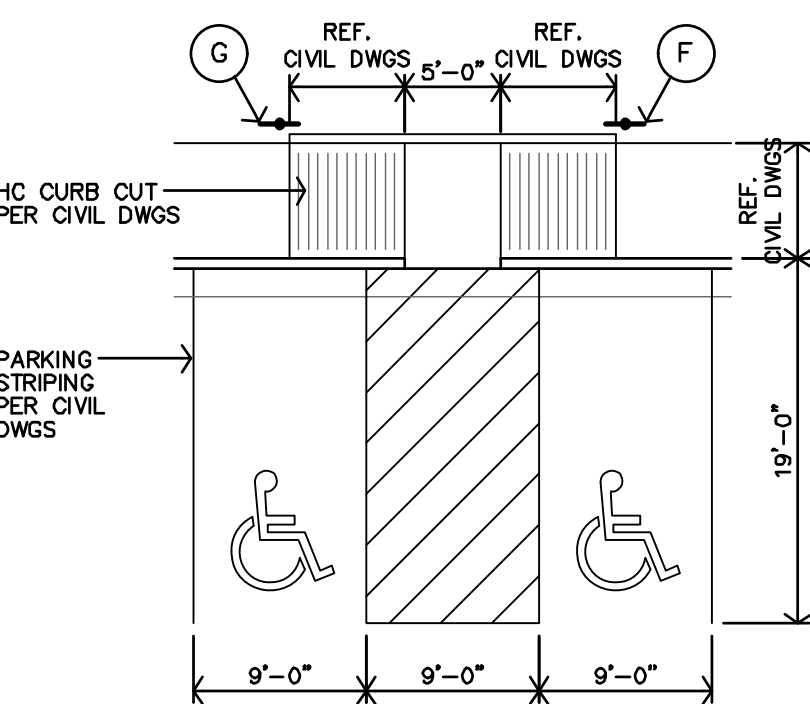

B HANDICAPPED PARKING
1"=10'-0"

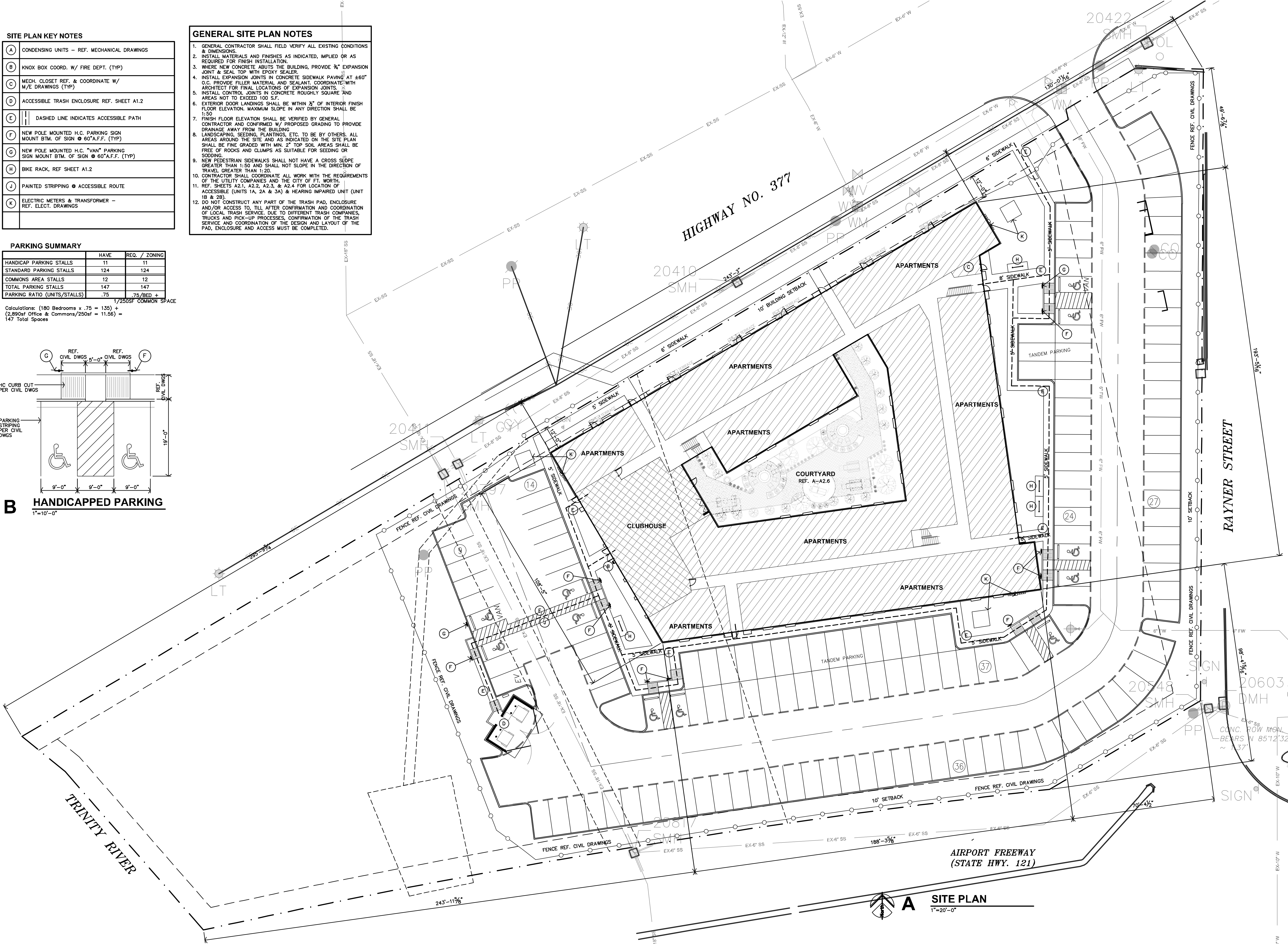

A SITE PLAN
1"=20'-0"

CLIFTON RIVERSIDE APARTMENTS
NEW APARTMENTS

FORT WORTH, TEXAS

Architects Planners Designers
1861 Main Street, Suite 301
Kansas City, MO 64108
770 N. North
P.O. Box 2028
Soling, KS 67402
785.827.0386
jgr@jgrarchitects.com

JONES GILLAM RENZ

REGISTERED ARCHITECT
STATE OF TEXAS
22415

REVISION:
DATE: 1-28-2022
JOB: 21-3137
SHEET: A1.1

COPYRIGHTED ©



5 BIKE WAVE RACK 543-1002
www.theparkcatalog.com

H BIKE RACK
NO SCALE

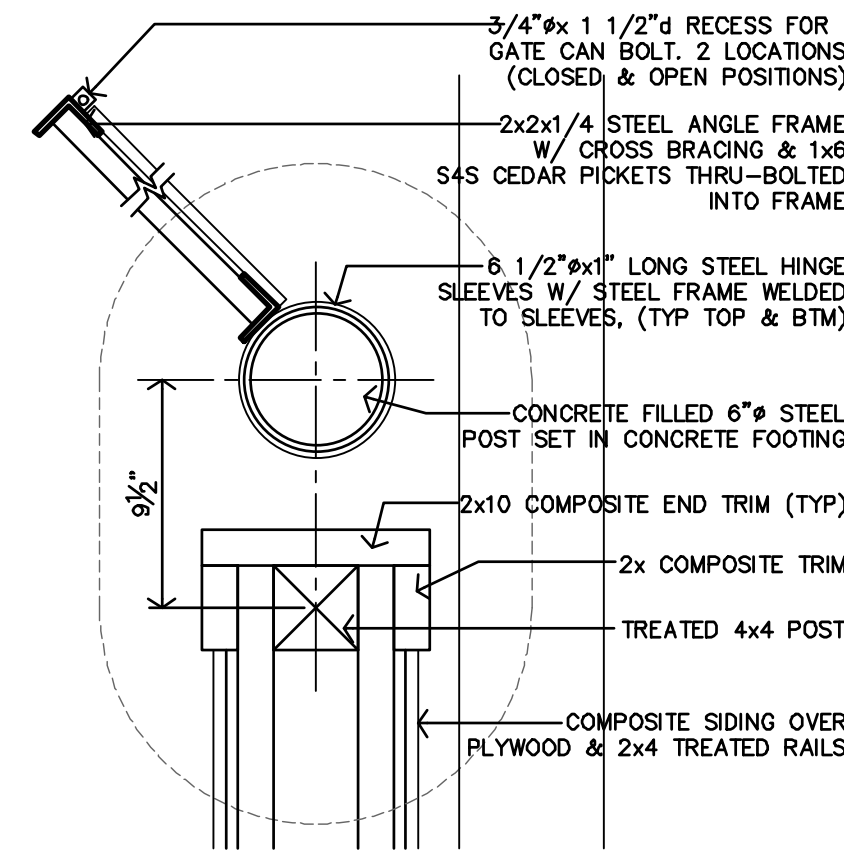

G DETAIL
1 1/2"=1'-0"

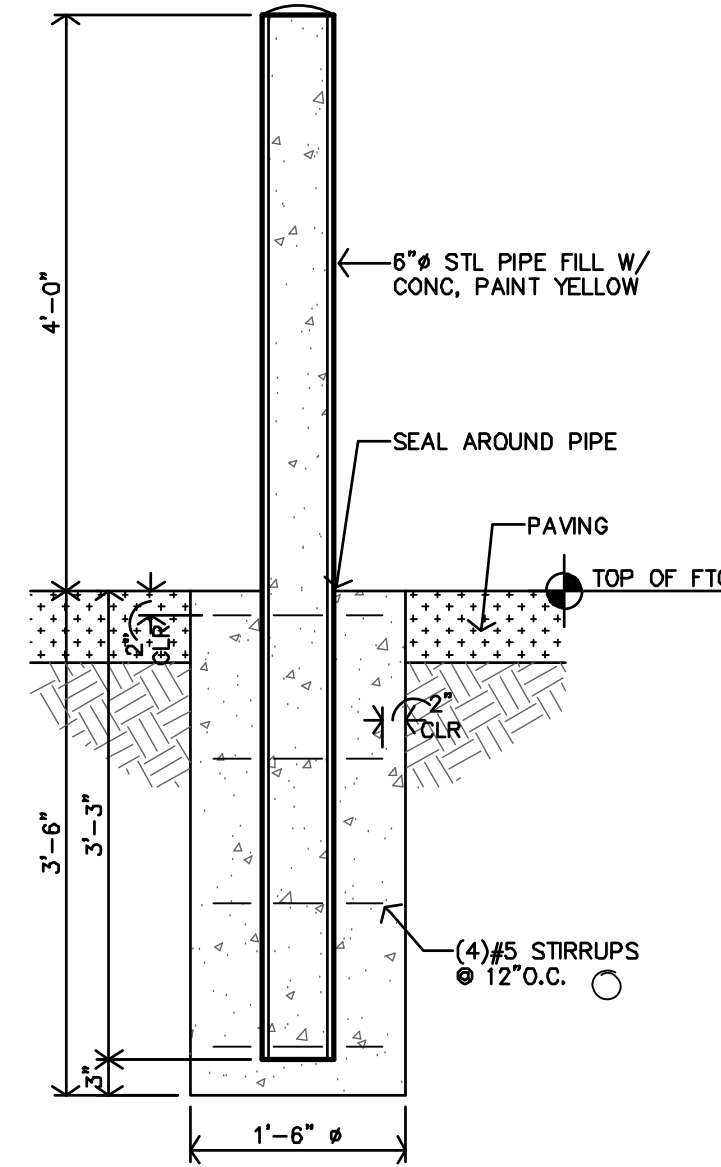

F BOLLARD DETAIL
3/4"=1'-0"

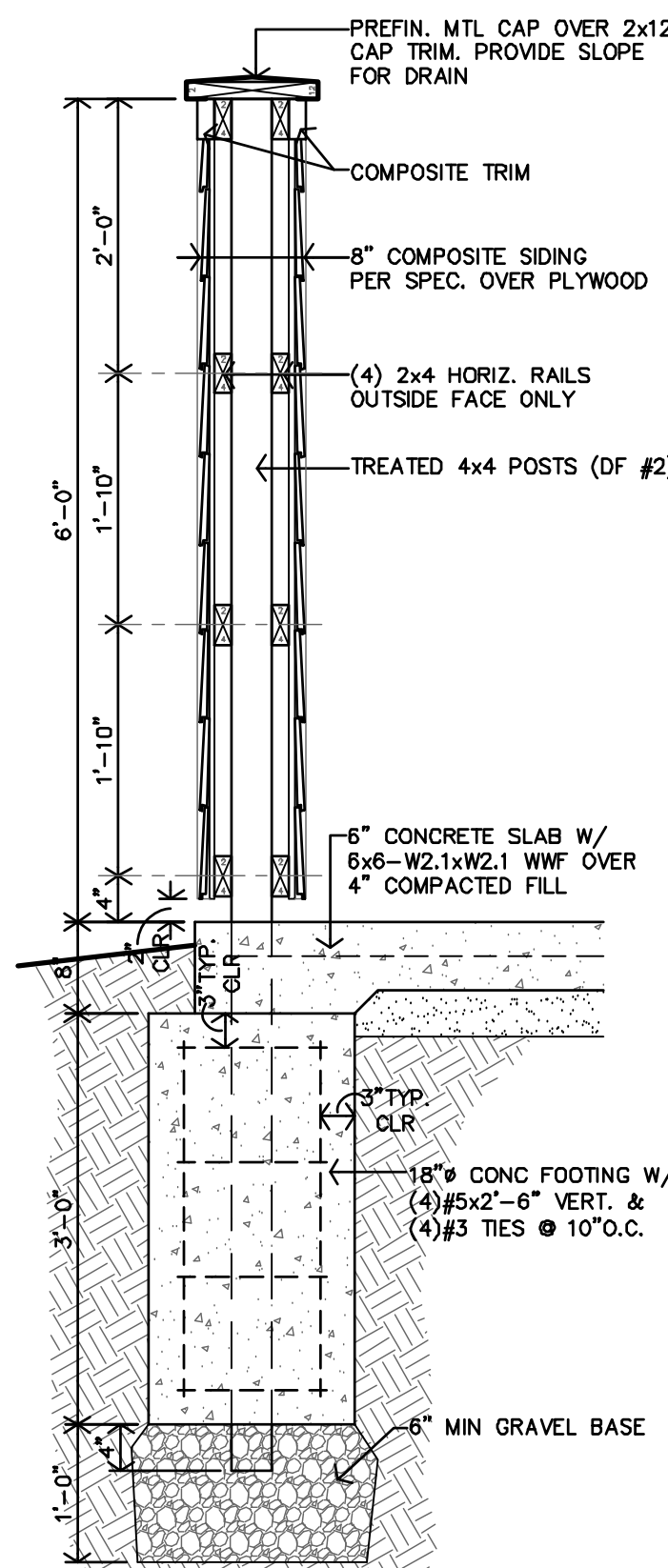

E TRASH ENCLOSURE SECTION
3/4"=1'-0"

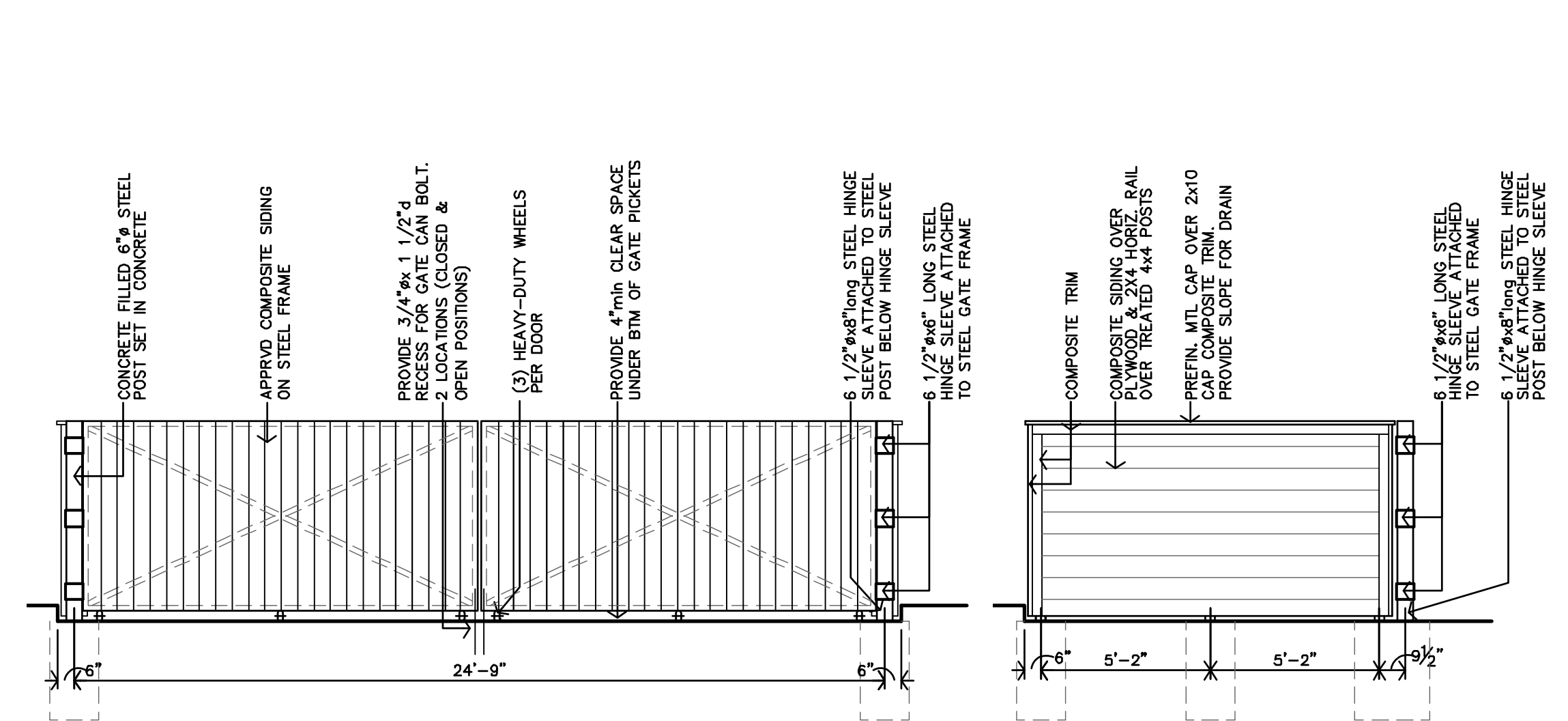

D TRASH ENCLOSURE FRONT ELEVATION
1/4"=1'-0"

C TRASH ENCLOSURE SIDE ELEVATION
1/4"=1'-0"

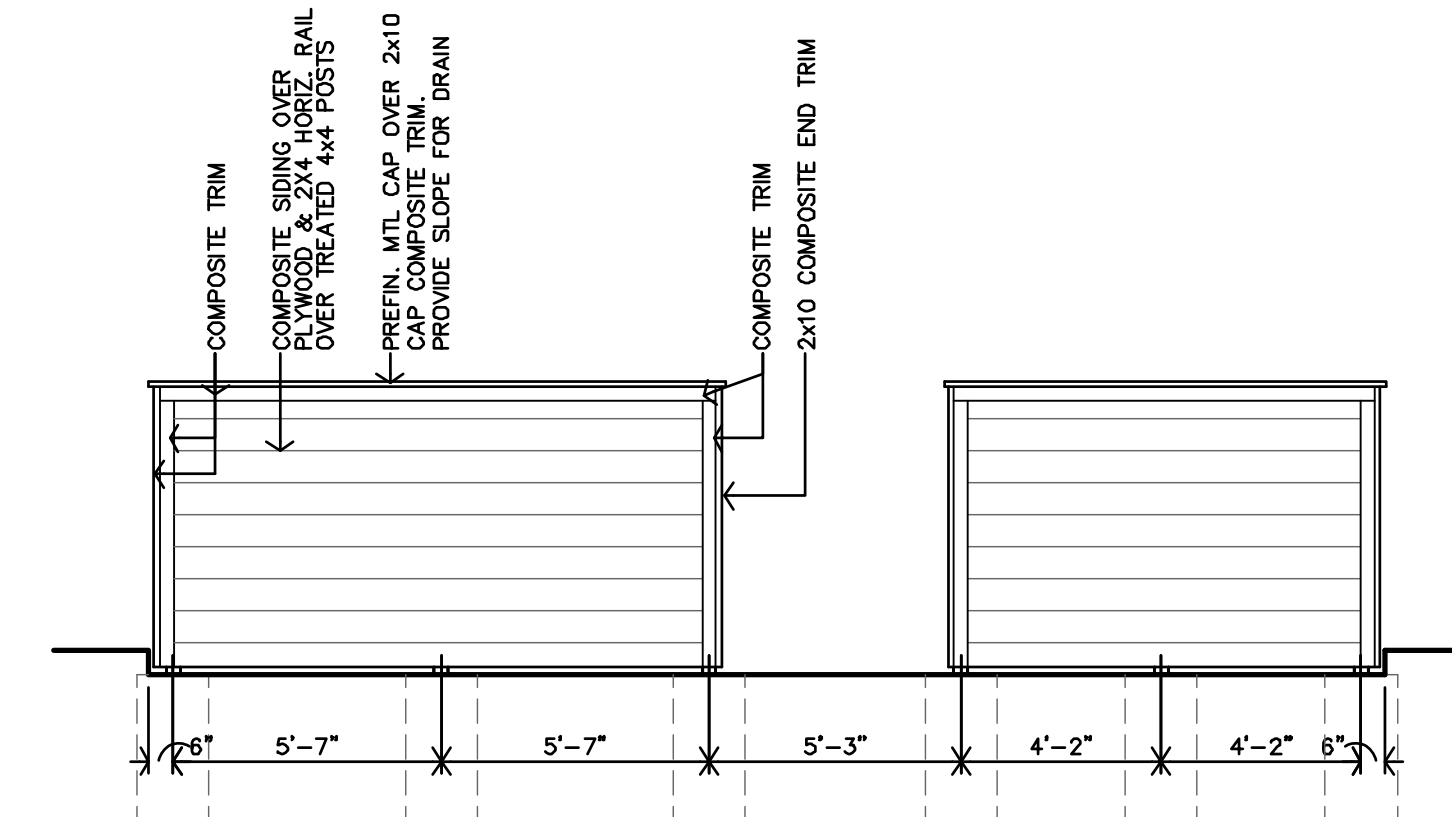

B TRASH ENCLOSURE FRONT ELEVATION
1/4"=1'-0"

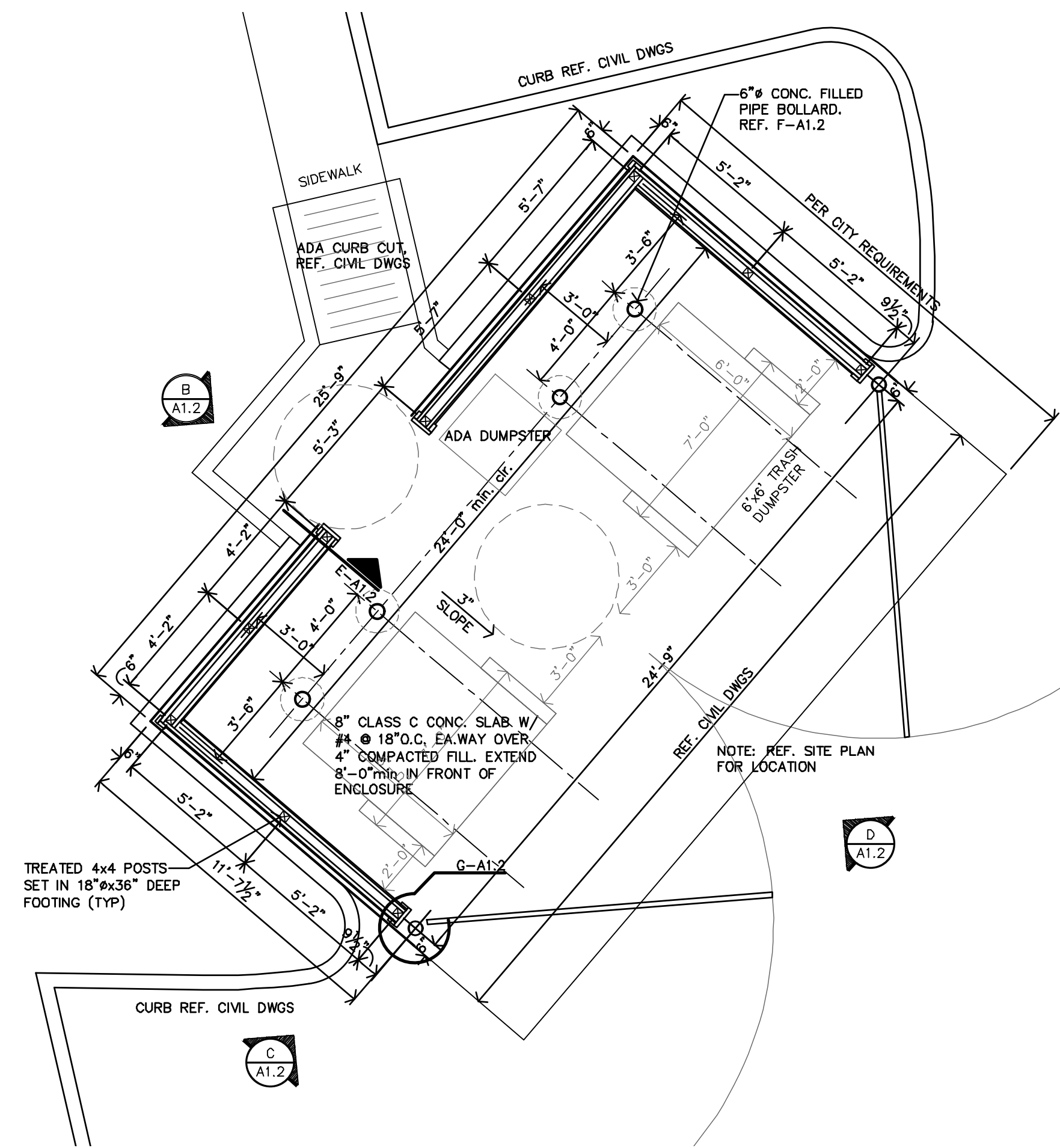

A TRASH ENCLOSURE PLAN
1/4"=1'-0"

ARCHITECTURAL GENERAL NOTES

- CONTRACTOR SHALL FIELD VERIFY ALL DIMENSIONS & CONDITIONS.
- INSTALL MATERIALS AND/OR FINISHES AS INDICATED, IMPLIED OR AS REQUIRED FOR COMPLETE & FINISHED INSTALLATION.
- ALL WORK SHALL BE IN CONFORMANCE W/ APPLICABLE BUILDING CODES & ORDINANCES.
- ALL NEW CONSTRUCTION SHALL BE IN CONFORMANCE TO ADA REQUIREMENTS. REFERENCE ADA FOR TYPICAL MINIMUM CLEARANCE REQ.
- IF THERE IS A DISCREPANCY BETWEEN DRAWINGS AND FIELD CONDITIONS NOTIFY ARCHITECT PRIOR TO PROCEEDING WITH WORK SO THAT ANY ISSUES MAY BE CLARIFIED.
- DOORS ARE TYPICALLY LOCATED WITH HINGE-SIDE JAMB 4" FROM ADJACENT WALL UNLESS NOTED OTHERWISE OR REQUIRED TO MEET LATCH-SIDE CLEARANCE PER ADA.
- FEC - INDICATES LOCATION OF RECESSED FIRE EXTINGUISHER CABINET. REF SPECS. AND DETAILS B/C-A2.1
- MHO - INDICATES DOOR WITH MAGNETIC HOLD OPEN.
- F.O.S. - DIMENSIONS TO THE EXTERIOR WALLS ARE TO THE FACE OF STUD U.N.O.
- FURNITURE SHOWN IS BY OWNER.
- INDICATES RADON PIPE LOCATION. REF. MEP DRAWINGS.

APARTMENT CHART

TYPE OF APARTMENT	1ST FLOOR	2ND FLOOR	3RD FLOOR	4TH FLOOR	TOTAL
ACCESSIBLE UNITS (w/ REMOVABLE TUB SEAT)	2A	1A, 2A		1A	4
ACCESSIBLE UNITS (w/ ROLL-IN SHOWER)	3A				1
TYPE-B HEARING/VISION IMPAIRED & ADAPTABLE UNITS			1B, 2B		2
TYPE-A UNITS			1A	2A	2
TYPE-B UNITS	1C, 2C, 3C 1D, 1E, 2D	1C, 2C, 3C 1D, 1E, 2D	1C, 2C, 3C 1D, 1E, 2D	1C, 2C, 3C 1D, 1E, 2D	85
TOTAL	22	25	25	22	94

1A,2A,3A - ACCESSIBLE & TYPE-A
1B,2B - HEARING & VISION
1C,2C,3C,1D,1E,2D - TYPE-B

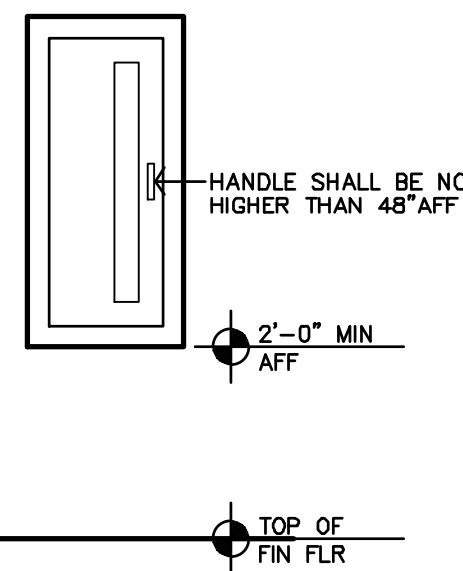

B TYPICAL FEC MOUNTING HGT
3/4"=1'-0"

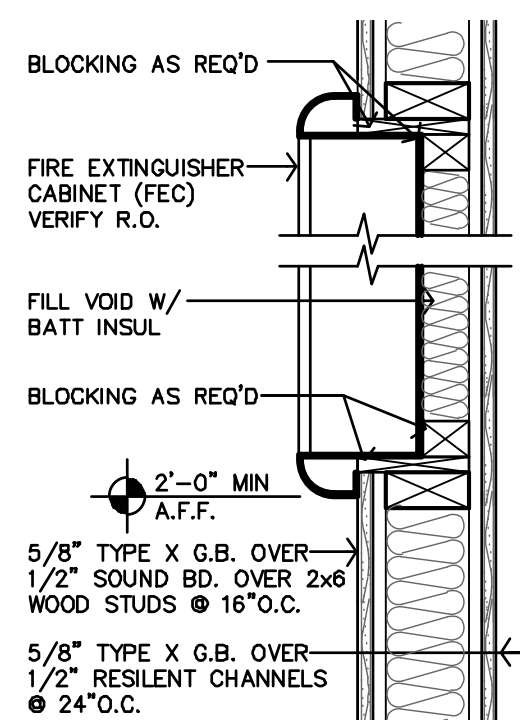

A FIRE EXTINGUISHER CABINET DTL @ 1HR WALL
1 1/2"=1'-0"

EXTERIOR PARTITION SCHEDULE

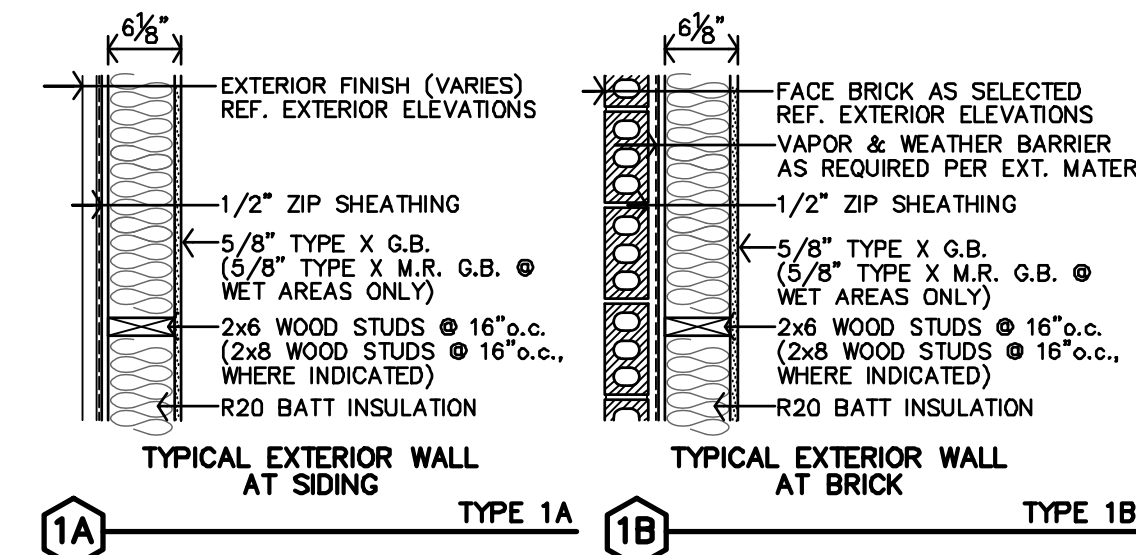

PARTITION NOTES:

- ALL WALLS TO BE EXTEND TO STRUCTURE UNLESS NOTED OR DETAILED OTHERWISE
- LOAD BEARING WALLS & FIRE PARTITIONS SHALL EXTEND TO DECK, SEALED SMOKE TIGHT.
- REF. SHEET CFP FOR ADDITIONAL CODE INFORMATION
- REF. STRUCTURAL FOR SHEAR WALL LOCATIONS, MATERIAL & SECTIONS
- FIRE BLOCKING REQUIRED PER 2015 IBC SEC. 708 & 718. @ 10'-0" O.C. VERT. & HORIZ. AND @ ALL BACK TO BACK ELECTRICAL OUTLETS. (1) LAYER - 5/8" TYPE X G.B. OR 1/2" PLYWOOD TO EXTEND THRU SPACE (REF. SHEET A4.9)
- ALL LISTED ASSEMBLIES ARE PROPRIETARY. ALL SUBSTITUTIONS SHALL FIRST BE SUBMITTED BEFORE INSTALLATION TO ARCHITECT FOR APPROVAL
- REF. SHEET A4.11 FOR FIRE PENETRATION REQUIREMENTS @ ALL PLUMBING CHASES AND ALL PENETRATIONS THRU RATED WALLS, FLOOR/CEILING & CEILING/ROOF ASSEMBLIES

INTERIOR PARTITION SCHEDULE

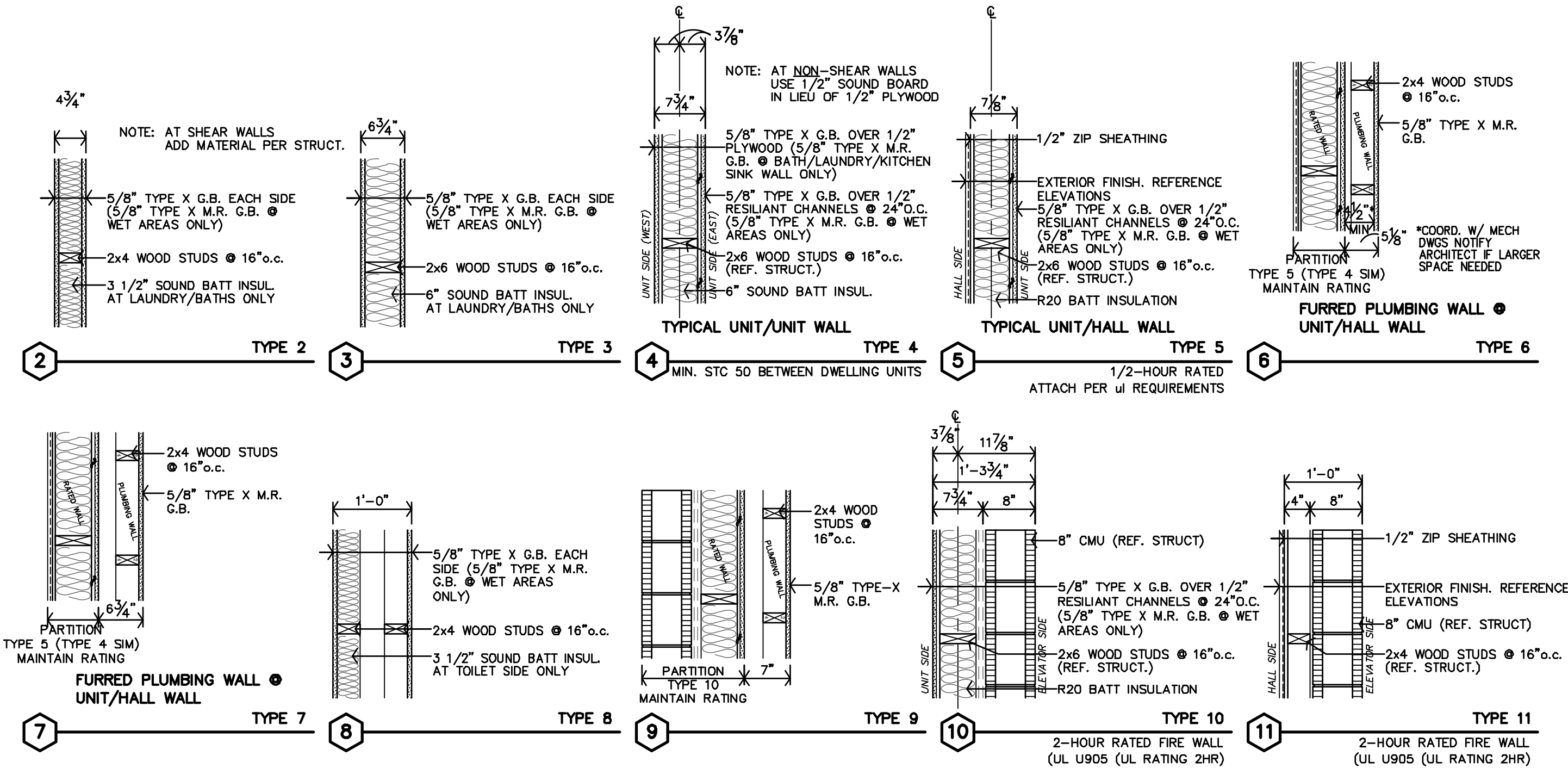

ASSEMBLIES

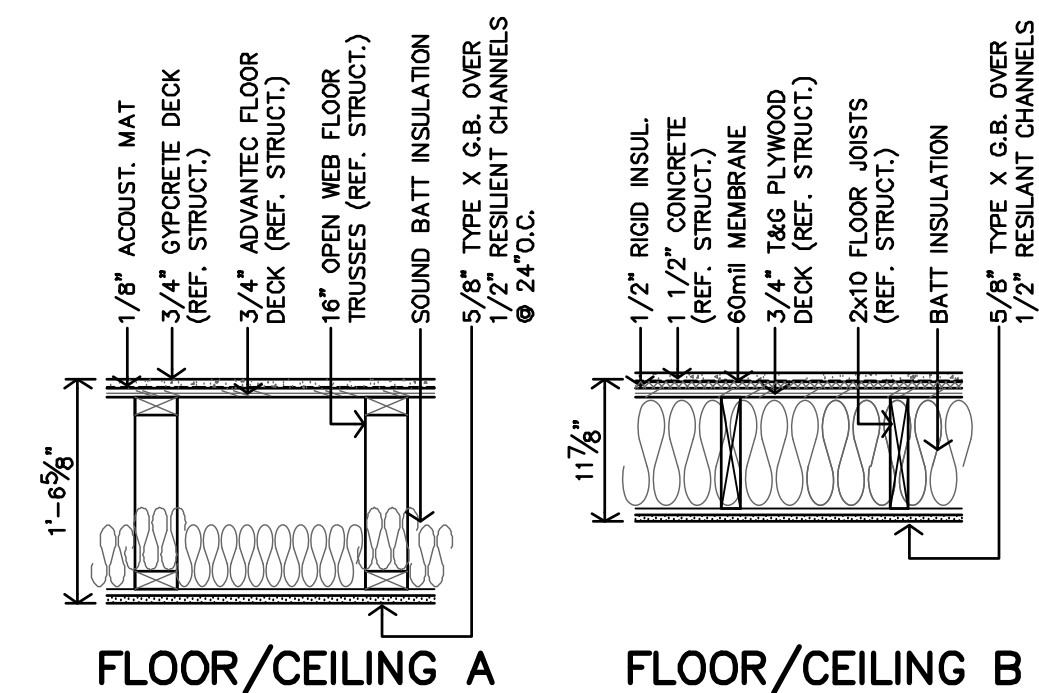

- NOTES:
- DRAFTSTOPPING TO BE INSTALLED PER 2015 IBC SECTION 708.4.2
 - FIRE BLOCKING REQUIRED PER 2015 IBC SEC. 718.2. (1) LAYER - 5/8" TYPE X G.B. OR 1/2" PLYWOOD TO EXTEND THRU SPACE (REF. Q-A4.11 & C-A4.7)
 - STC RATING 50 MIN & IC RATING 50 MIN PER IBC 2015, SEC. 1206.2 & 1206.3

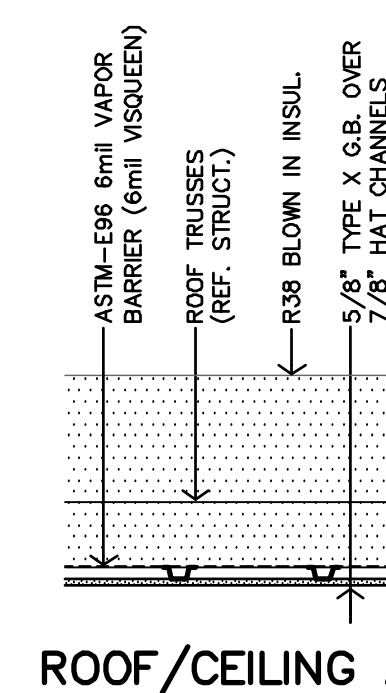

- NOTES:
- DRAFTSTOPPING TO BE INSTALLED PER 2015 IBC SECTION 708.4.2
 - FIRE BLOCKING REQUIRED PER 2018 IBC SEC. 718.2. (1) LAYER - 5/8" TYPE X G.B. OR 1/2" PLYWOOD TO EXTEND THRU SPACE (REF. Q-A4.11 & C-A4.7)

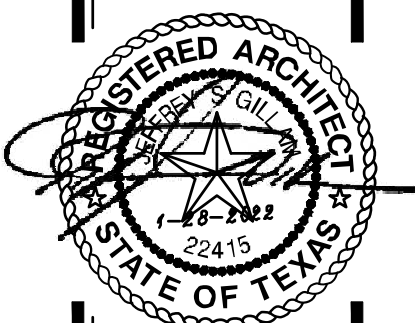

REVISION:
DATE: 1-28-2022
JOB: 21-3137
SHEET:

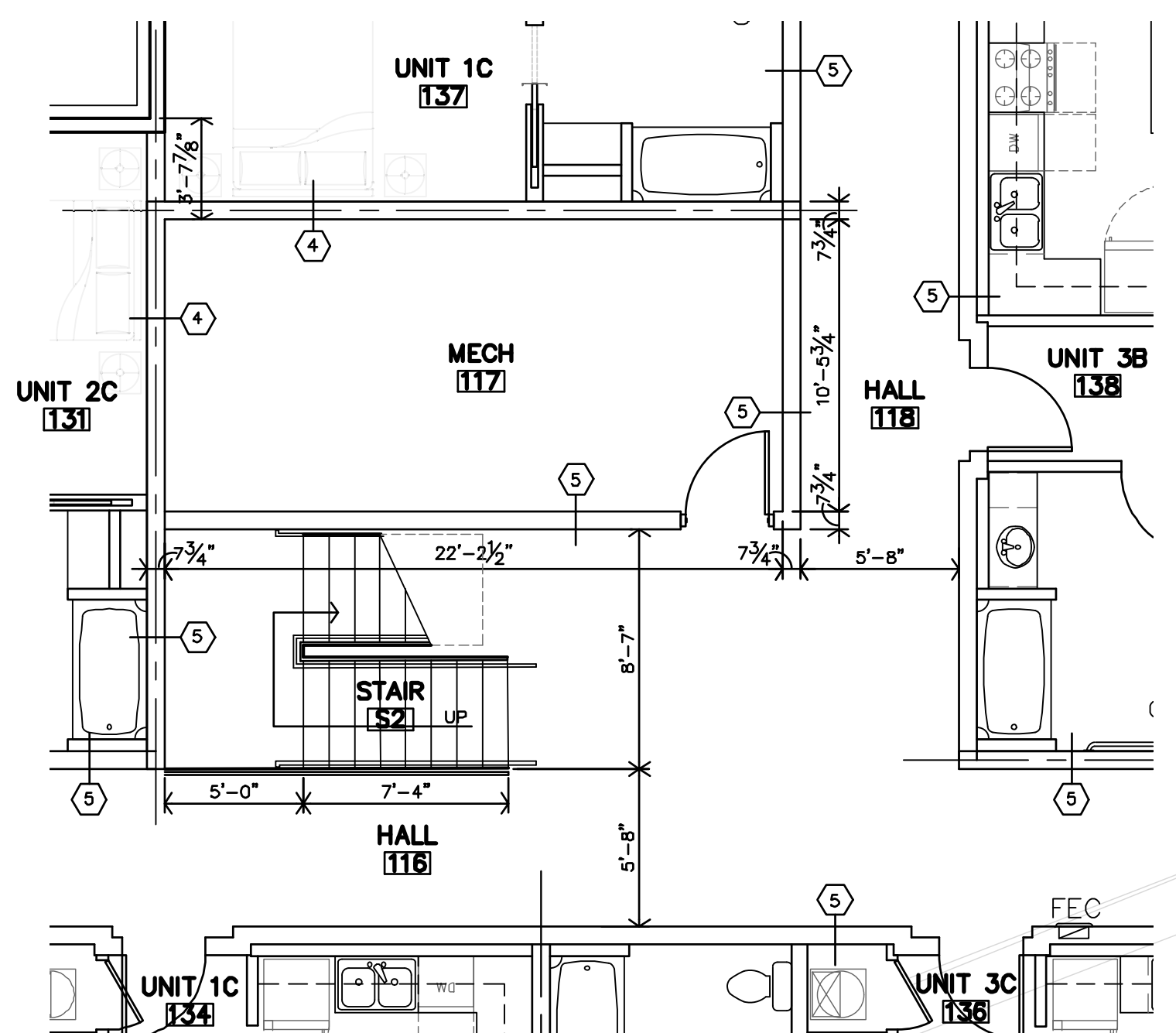

B ENLARGED PLAN
3/16"=1'-0"

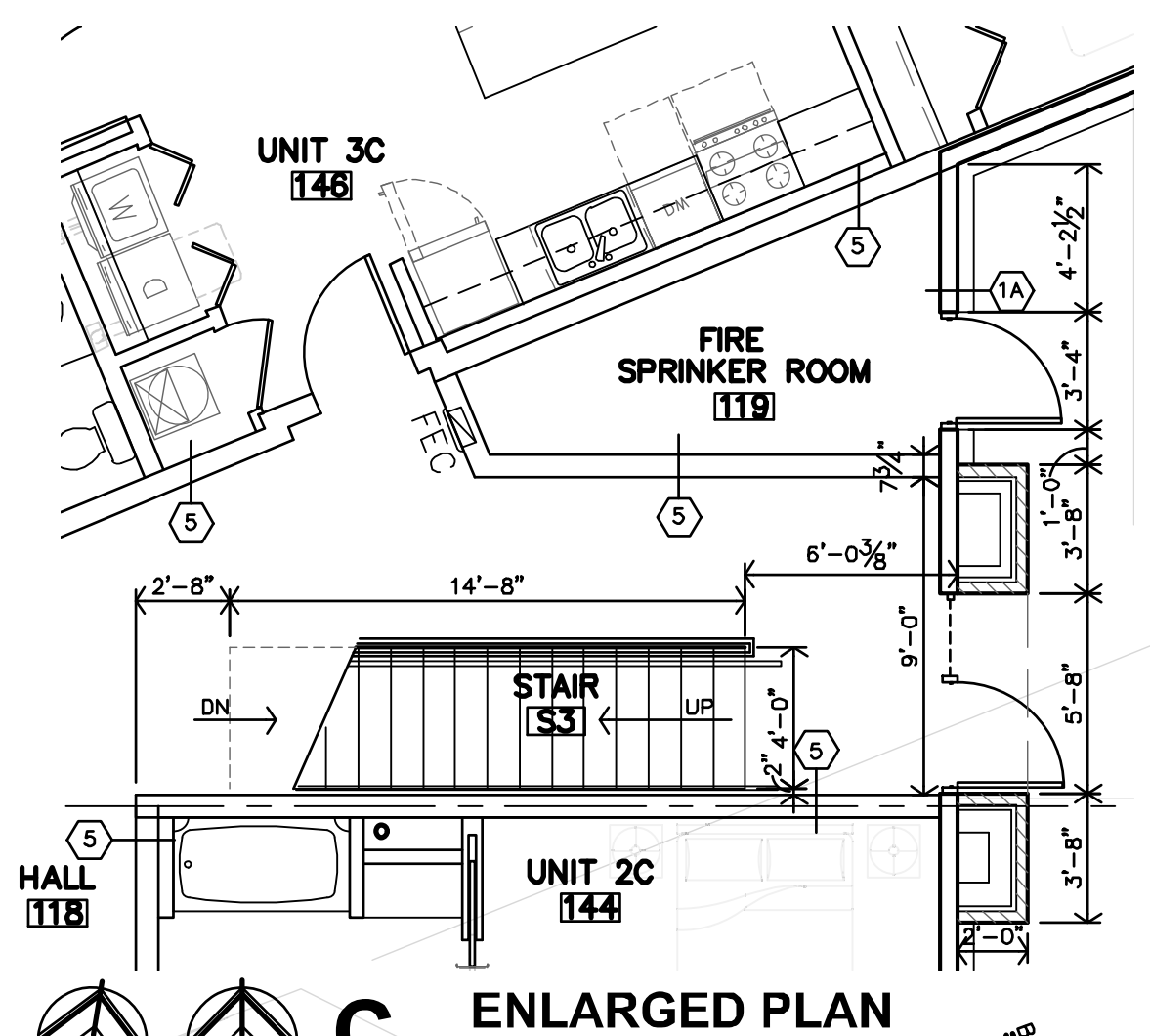

C ENLARGED PLAN
3/16"=1'-0"

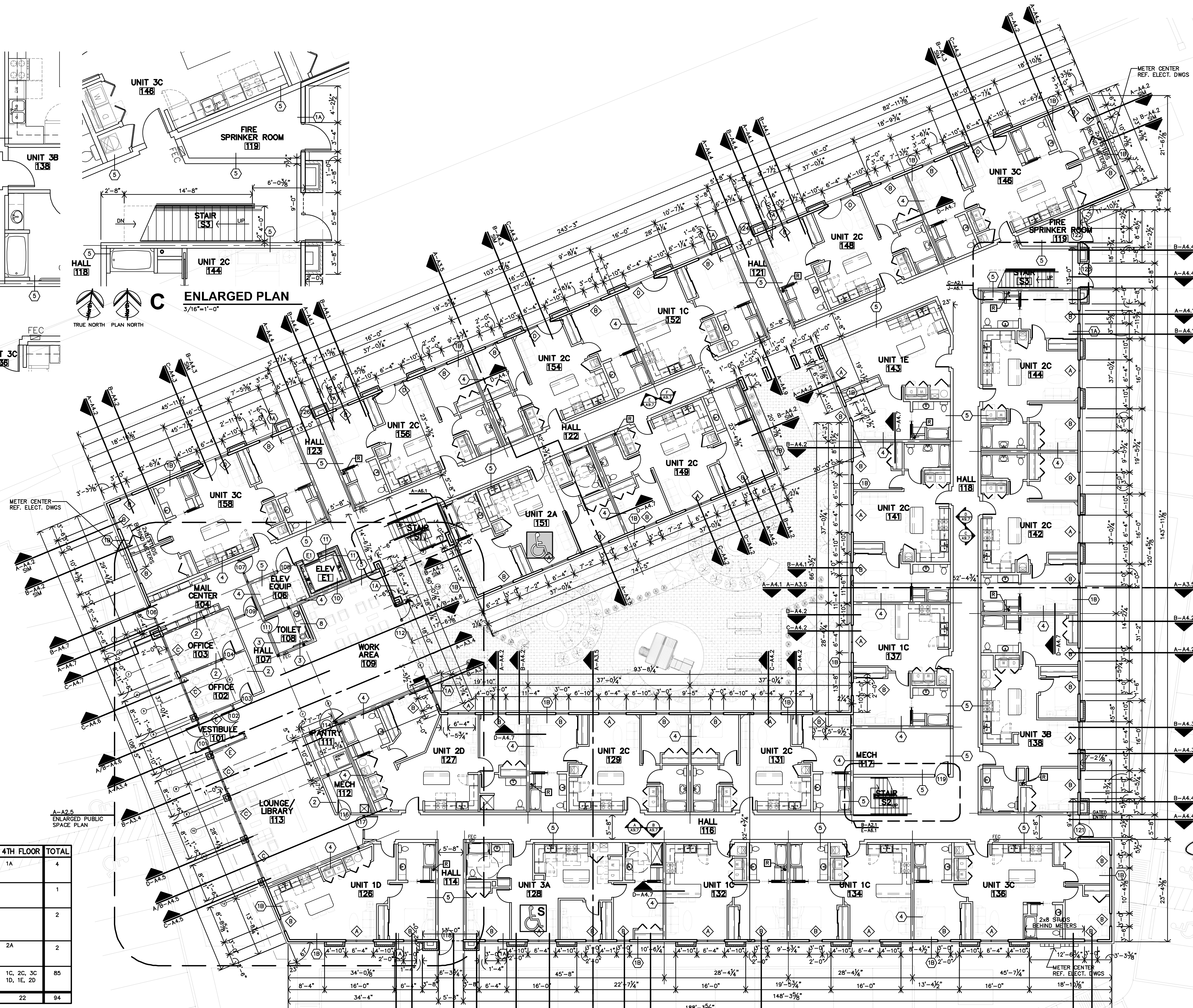

- NOTES**
- HALLWAYS HAVE SLOPING FLOORS REF. A8.1, A8.2, A8.3 & A8.4
 - REF. SHEET A2.0 FOR GENERAL NOTES.
 - REF. SHEET A2.0 FOR PARTITION SCHEDULES & ASSEMBLIES
 - FURR WALLS TO HIDE 4" ROOF DRAIN PIPES SHOWN PER PLUMBING SHEETS @ UNIT CLOSETS & CORNER LOCATIONS.

APARTMENT CHART

TYPE OF APARTMENT	1ST FLOOR	2ND FLOOR	3RD FLOOR	4TH FLOOR	TOTAL
ACCESSIBLE UNITS (w/ REMOVEABLE TUB SEAT)	2A	1A, 2A		1A	4
ACCESSIBLE UNITS (w/ ROLL-IN SHOWER)	3A				1
TYPE-B HEARING/VISION IMPAIRED & ADAPTABLE UNITS			1B, 2B		2
TYPE-A UNITS			1A	2A	2
TYPE-B UNITS	1C, 2C, 3C 1D, 1E, 2D	1C, 2C, 3C 1D, 1E, 2D	1C, 2C, 3C 1D, 1E, 2D	1C, 2C, 3C 1D, 1E, 2D	85
TOTAL	22	25	25	22	94

1A,2A,3A - ACCESSIBLE & TYPE-A
1B,2B - HEARING & VISION
1C,2C,3C,1D,1E,2D - TYPE-B

A FIRST FLOOR
3/32"=1'-0"

Architects Planners Designers
730 N. North
P.O. BOX 2928
Salina, KS 67402
1861 Main Street, Suite 301
Kansas City, MO 64108
jgr@jgarchitects.com
785.827.0386

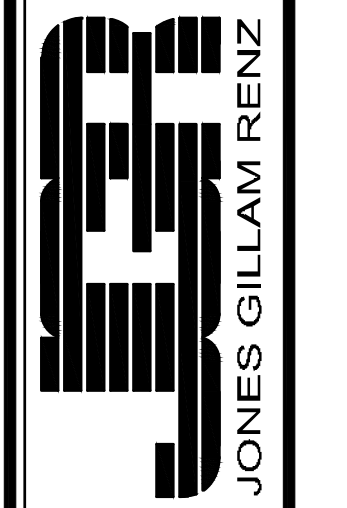

CLIFTON RIVERSIDE APARTMENTS
NEW APARTMENTS
FORT WORTH, TEXAS



REVISION:
DATE: 1-28-2022
JOB: 21-3137
SHEET:

A2.1

COPYRIGHTED ©

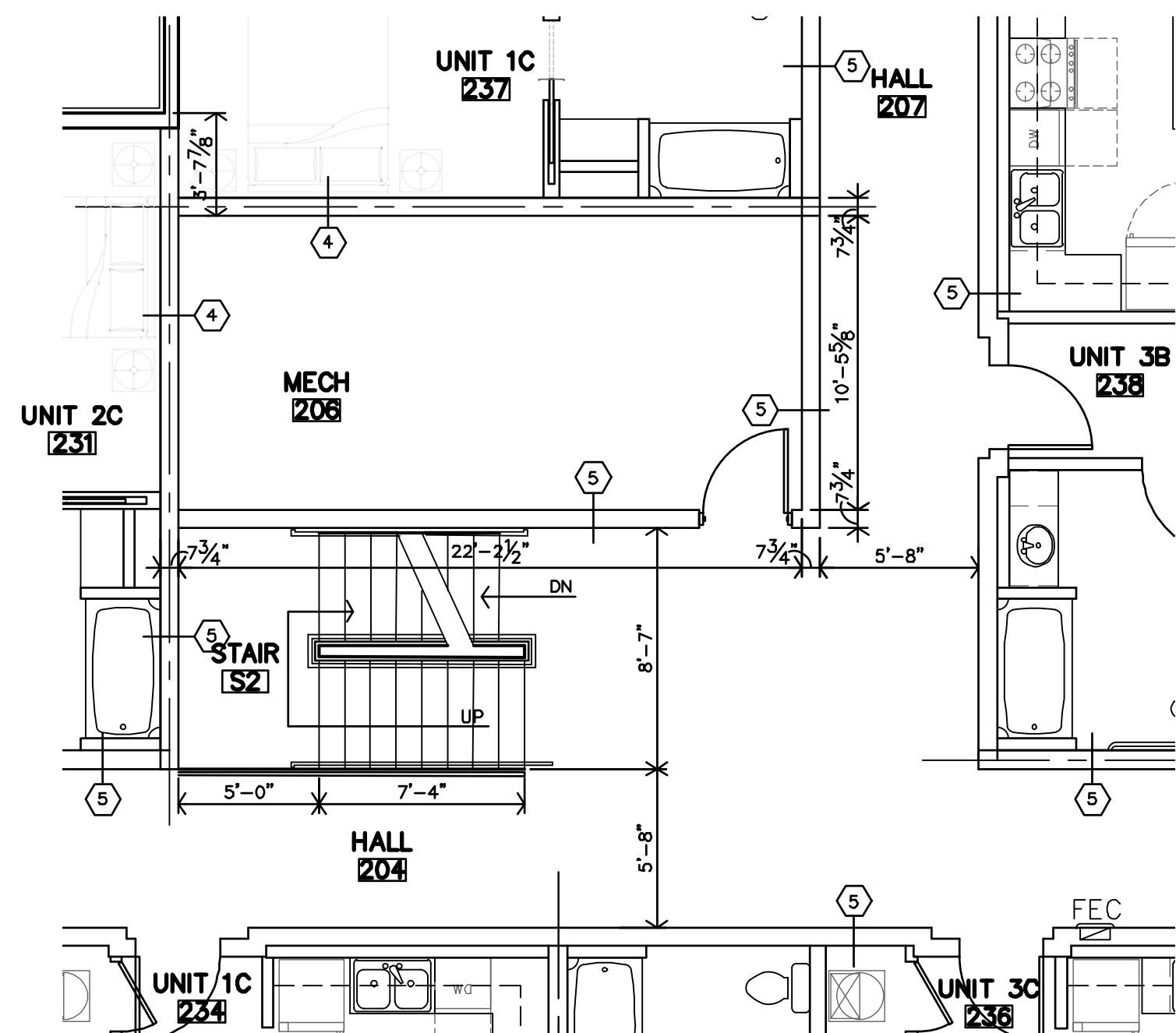

B ENLARGED PLAN
3/16"=1'-0"

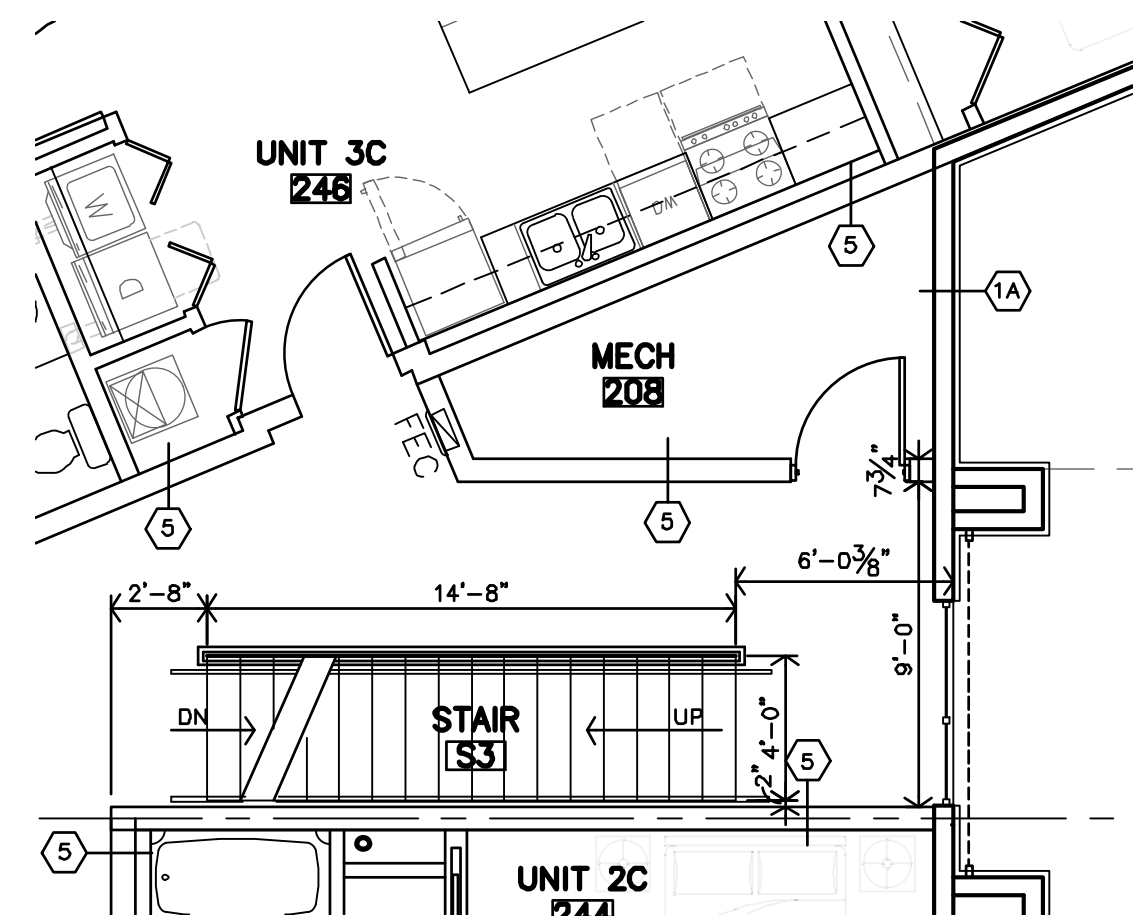
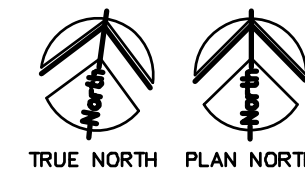

C ENLARGED PLAN
3/16"=1'-0"

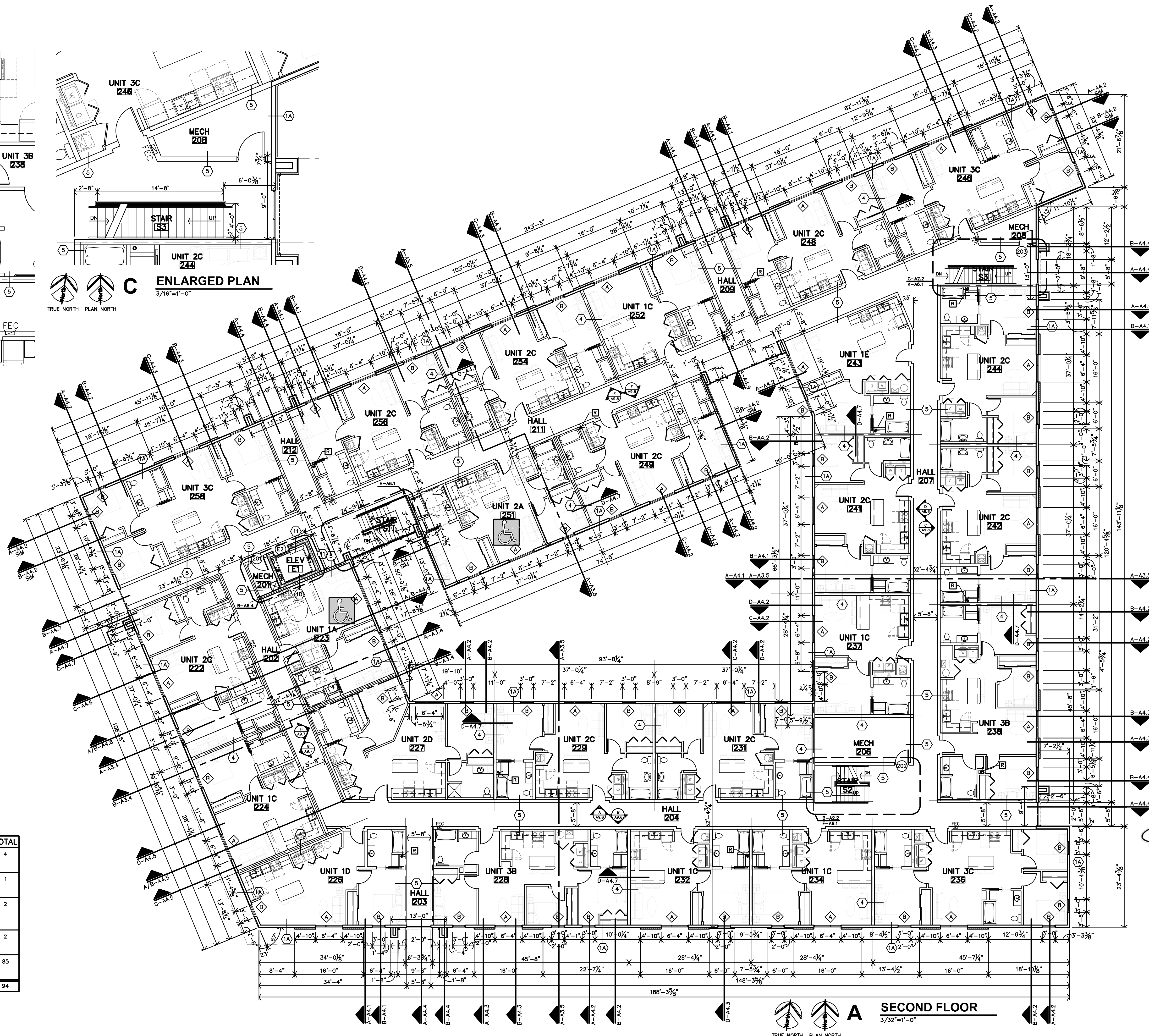
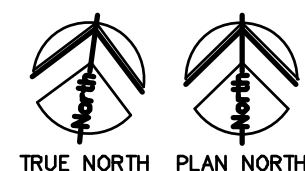

- NOTES**
- HALLWAYS HAVE SLOPING FLOORS REF. A9.1, A9.2, A9.3 & A9.4
 - REF. SHEET A2.0 FOR GENERAL NOTES.
 - REF. SHEET A2.0 FOR PARTITION SCHEDULES & ASSEMBLIES
 - FURR WALLS TO HIDE 4" ROOF DRAIN PIPES SHOWN PER PLUMBING SHEETS @ UNIT CLOSETS & CORNER LOCATIONS.

APARTMENT CHART

TYPE OF APARTMENT	1ST FLOOR	2ND FLOOR	3RD FLOOR	4TH FLOOR	TOTAL
ACCESSIBLE UNITS (w/ REMOVEABLE TUB SEAT)	2A	1A, 2A	3RD FLOOR	1A	4
ACCESSIBLE UNITS (w/ ROLL-IN SHOWER)	3A				1
TYPE-B HEARING/VISION IMPAIRED & ADAPTABLE UNITS			1B, 2B		2
TYPE-A UNITS			1A	2A	2
TYPE-B UNITS	1C, 2C, 3C 1D, 1E, 2D	1C, 2C, 3C 1D, 1E, 2D	1C, 2C, 3C 1D, 1E, 2D	1C, 2C, 3C 1D, 1E, 2D	85
TOTAL	22	25	25	22	94

1A,2A,3A - ACCESSIBLE & TYPE-A
1B,2B - HEARING & VISION
1C,2C,3C,1D,1E,2D - TYPE-B

A SECOND FLOOR
3/32"=1'-0"

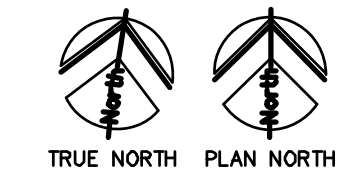

Architects Planners Designers
1861 Main Street, Suite 301
Kansas City, MO 64108
785.827.0386
jgr@architects.com

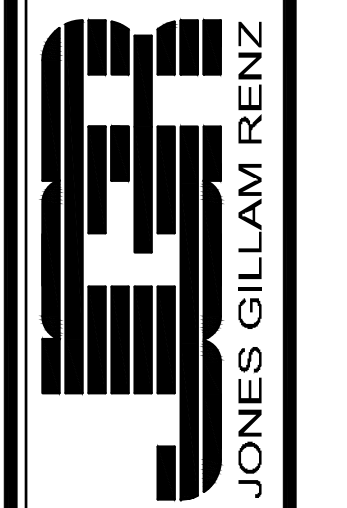

CLIFTON RIVERSIDE APARTMENTS
NEW APARTMENTS
FORT WORTH, TEXAS



REVISION:
DATE: 1-28-2022
JOB: 21-3137
SHEET:

A2.2
COPYRIGHTED ©

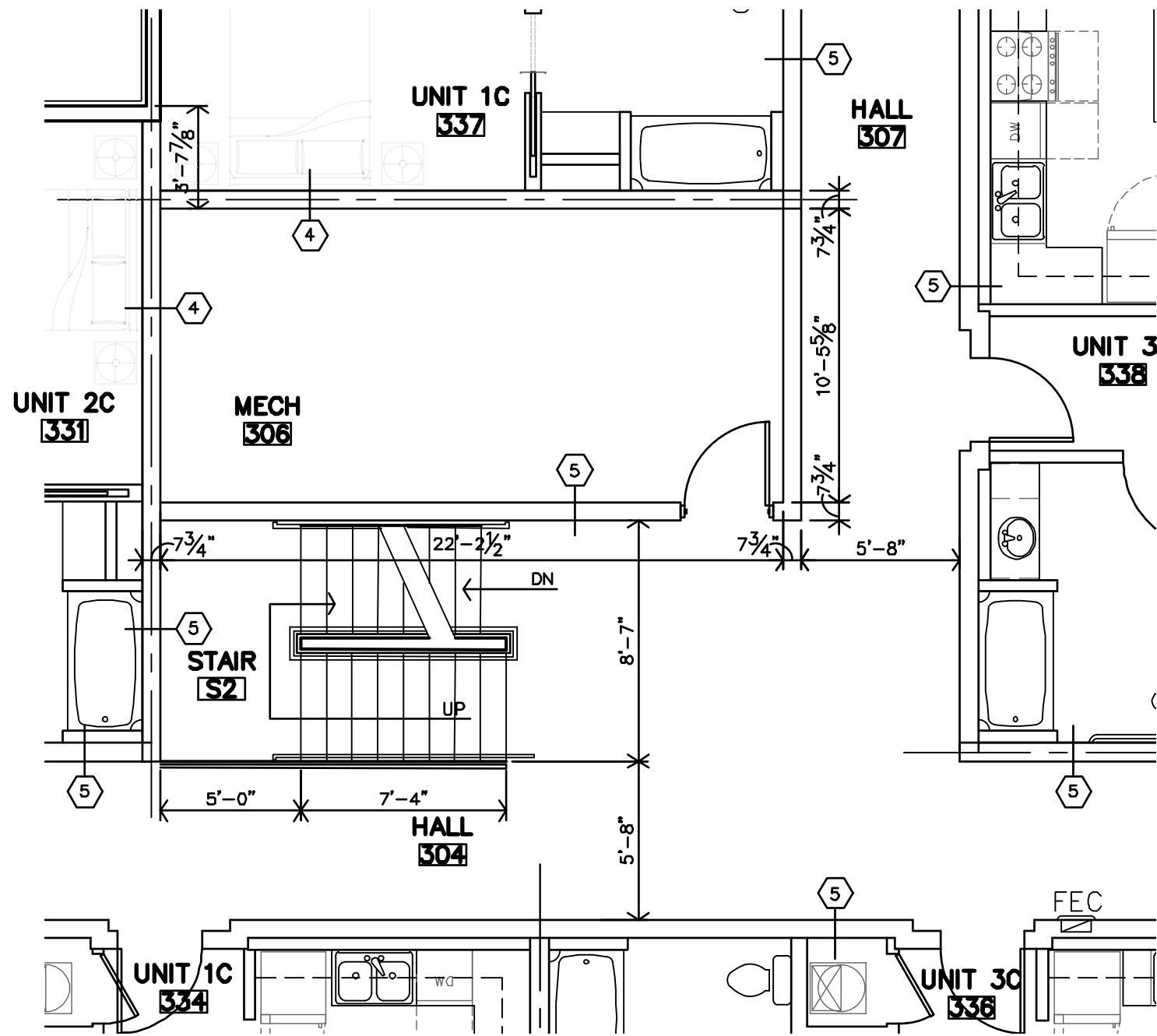

B ENLARGED PLAN
3/16"=1'-0"

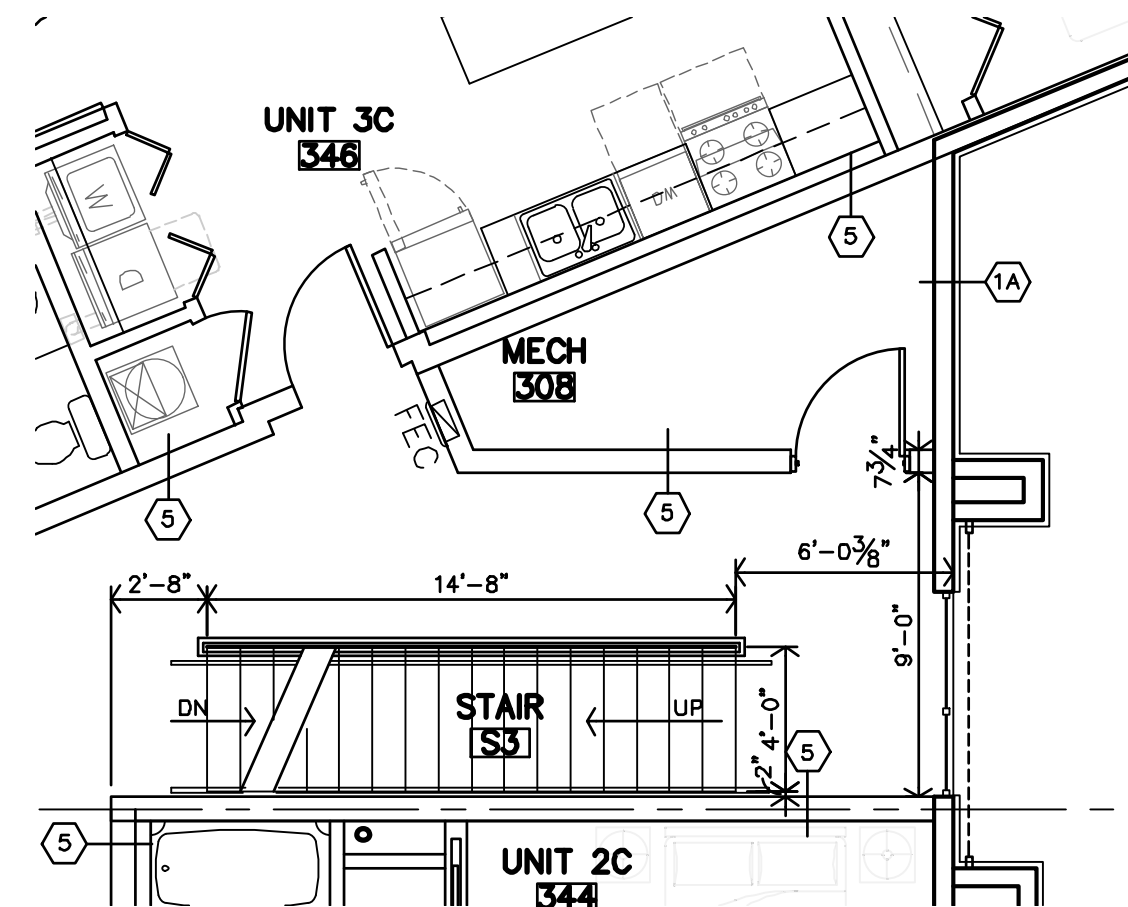

C ENLARGED PLAN
3/16"=1'-0"

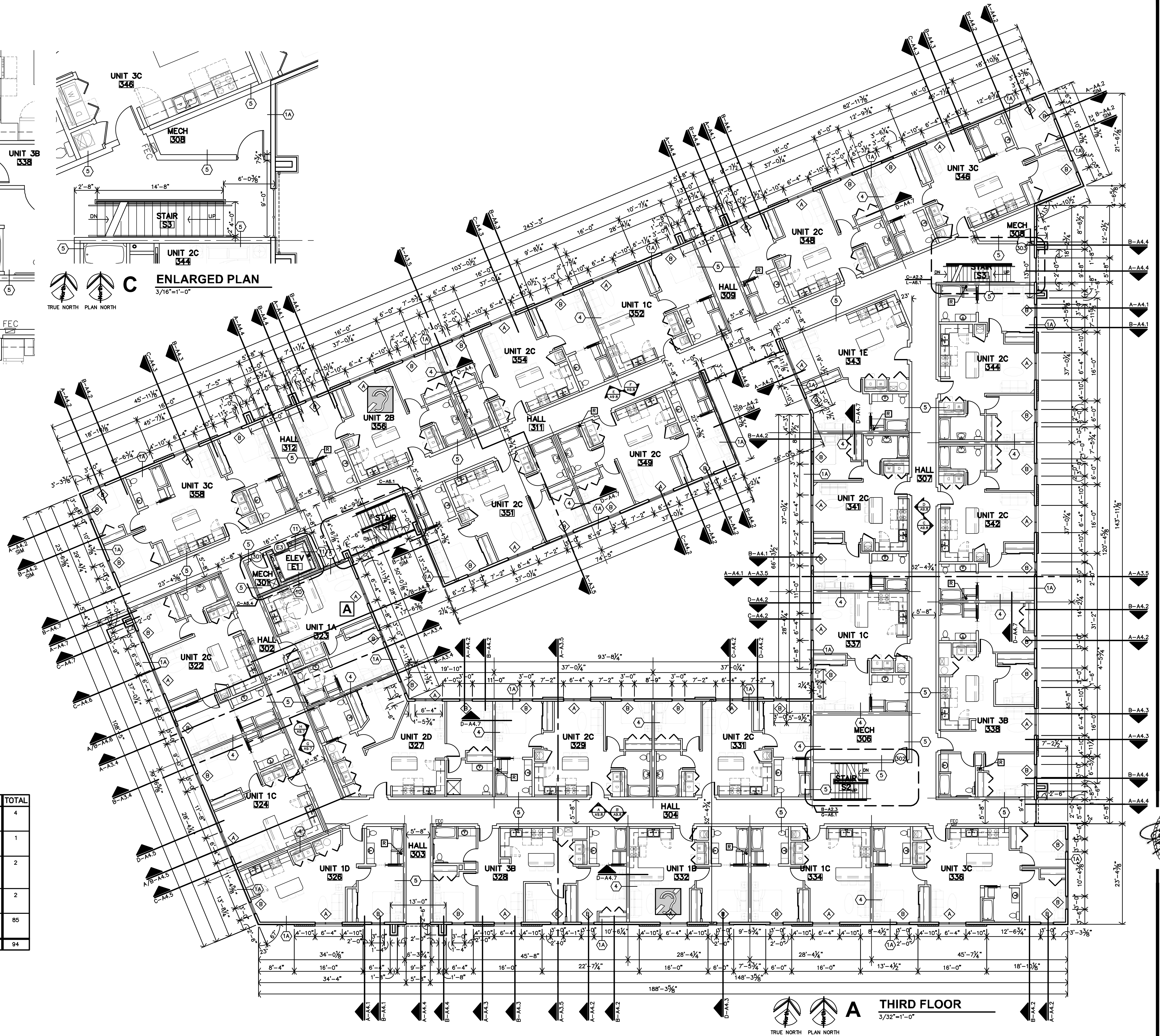

NOTES
1. REF. SHEET A2.0 FOR GENERAL NOTES.
2. REF. SHEET A2.0 FOR PARTITION SCHEDULES & ASSEMBLIES

APARTMENT CHART

TYPE OF APARTMENT	1ST FLOOR	2ND FLOOR	3RD FLOOR	4TH FLOOR	TOTAL
ACCESSIBLE UNITS (w/ REMOVEABLE TUB SEAT)	2A	1A, 2A		1A	4
ACCESSIBLE UNITS (w/ ROLL-IN SHOWER)	3A				1
TYPE-B HEARING/VISION IMPAIRED & ADAPTABLE UNITS			1B, 2B		2
TYPE-A UNITS			1A	2A	2
TYPE-B UNITS	1C, 2C, 3C 1D, 1E, 2D	1C, 2C, 3C 1D, 1E, 2D	1C, 2C, 3C 1D, 1E, 2D	1C, 2C, 3C 1D, 1E, 2D	85
TOTAL	22	25	25	22	94

1A, 2A, 3A - ACCESSIBLE & TYPE-A
1B, 2B - HEARING & VISION
1C, 2C, 3C, 1D, 1E, 2D - TYPE-B

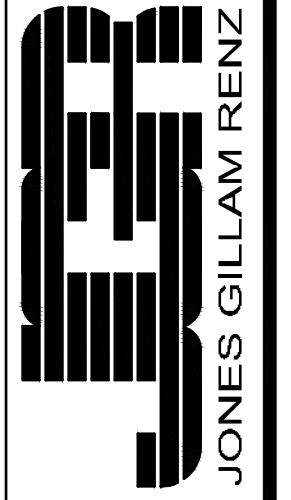

REVISION:
DATE: 1-28-2022
JOB: 21-3137
SHEET:

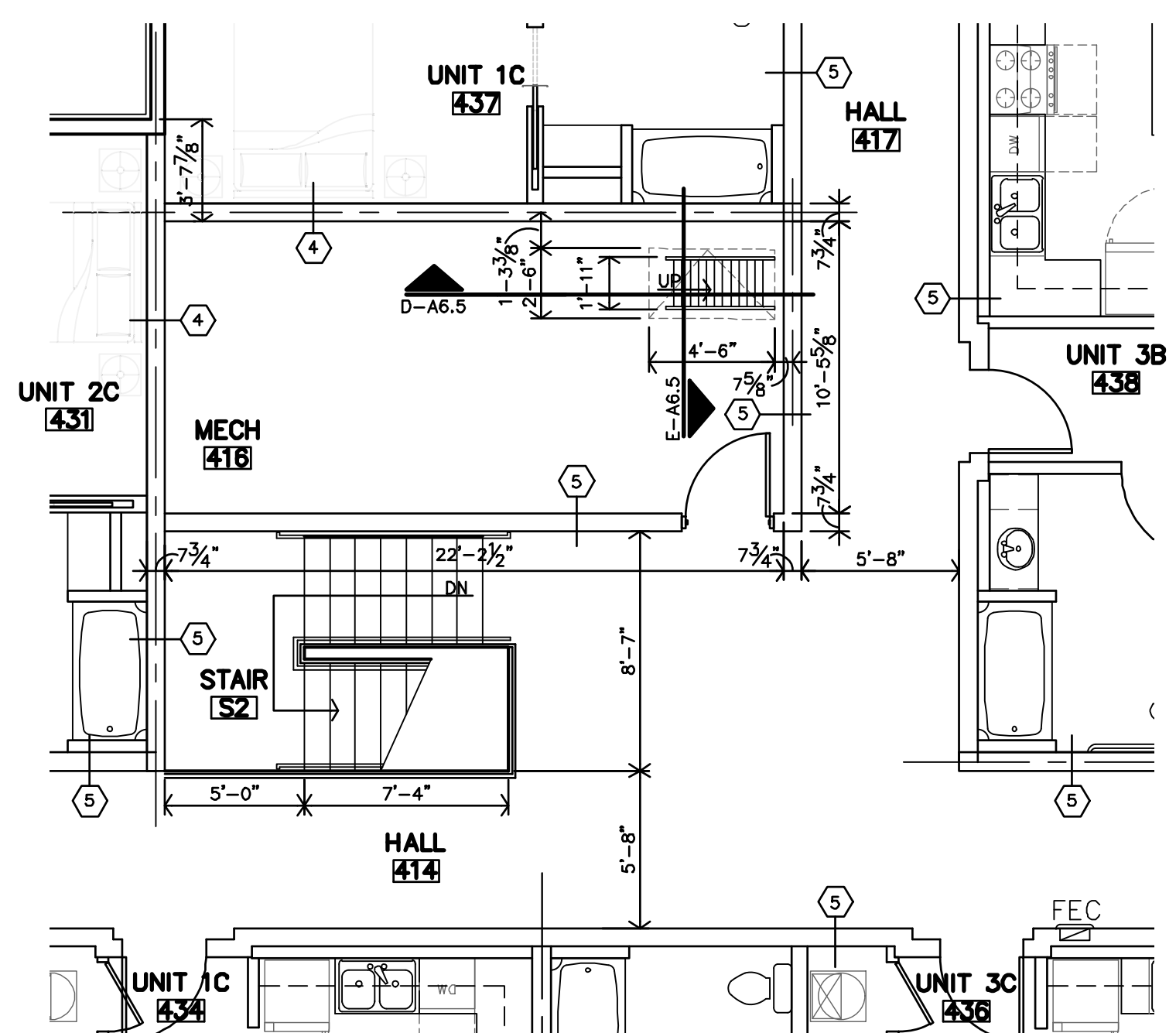

B ENLARGED PLAN
3/16"=1'-0"

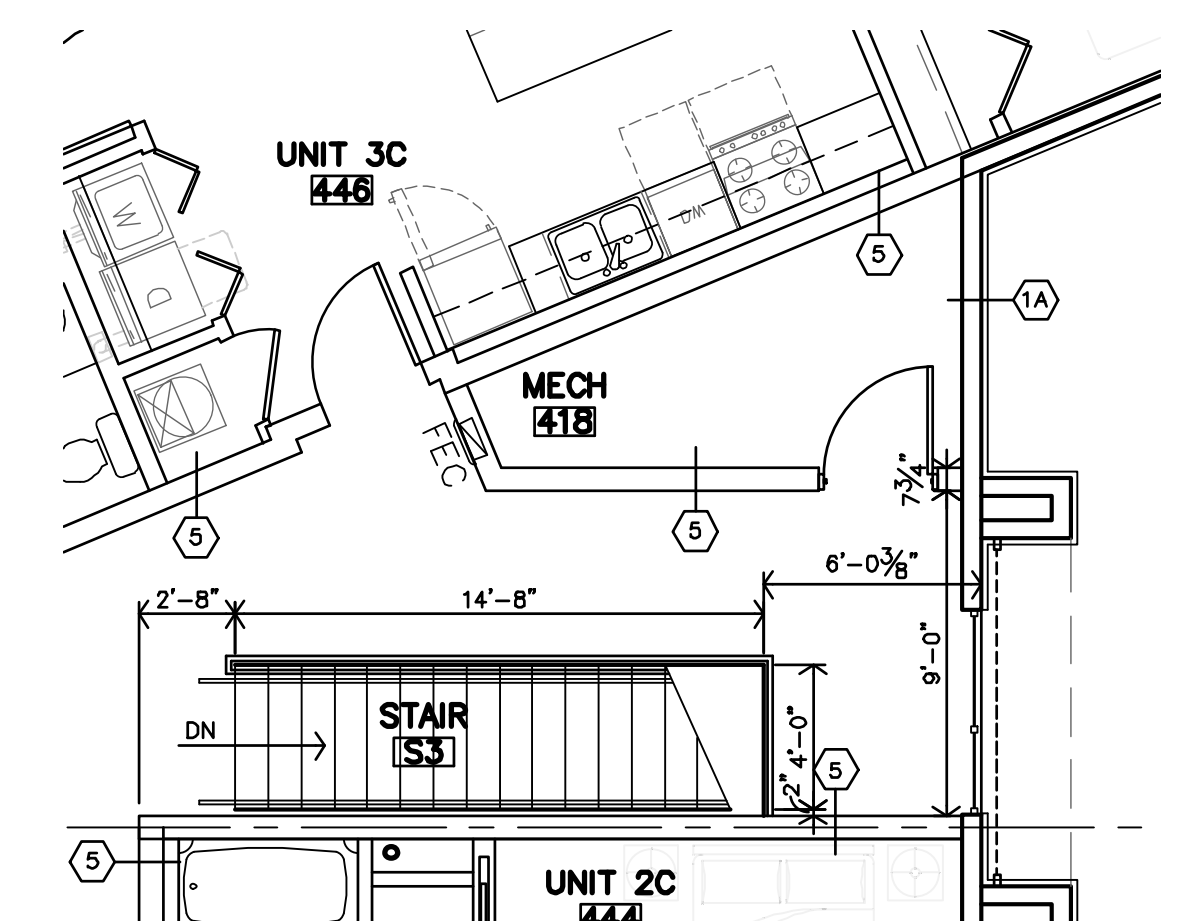

C ENLARGED PLAN
3/16"=1'-0"

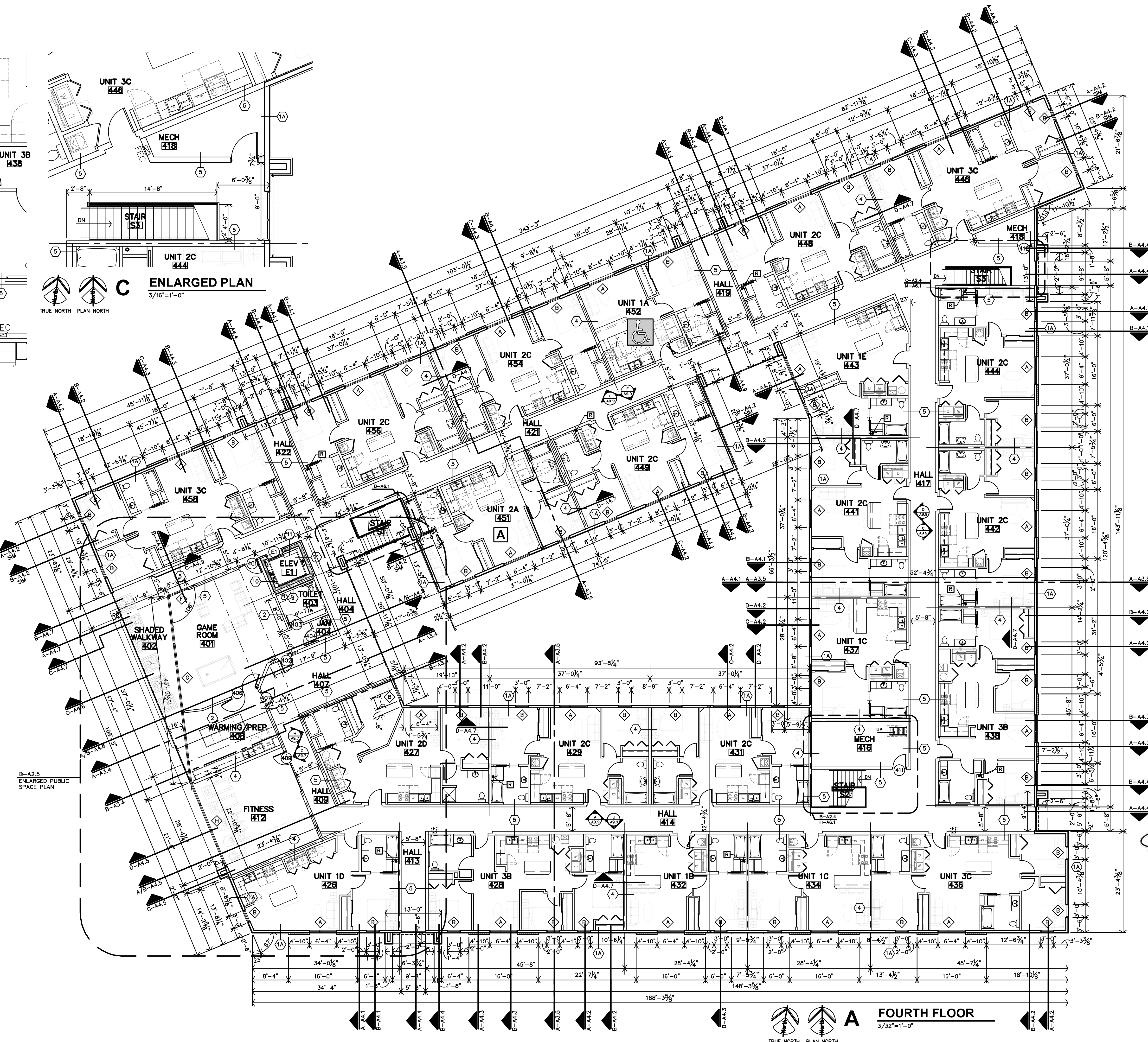

- NOTES**
- HALLWAYS HAVE SLOPING FLOORS REF. A9.1, A9.2, A9.3 & A9.4
 - REF. SHEET A2.0 FOR GENERAL NOTES.
 - REF. SHEET A2.0 FOR PARTITION SCHEDULES & ASSEMBLIES
 - FURR WALLS TO HIDE 4" ROOF DRAIN PIPES SHOWN PER PLUMBING SHEETS @ UNIT CLOSETS & CORNER LOCATIONS.

APARTMENT CHART

TYPE OF APARTMENT	1ST FLOOR	2ND FLOOR	3RD FLOOR	4TH FLOOR	TOTAL
ACCESSIBLE UNITS (w/ REMOVEABLE TUB SEAT)	2A	1A, 2A		1A	4
ACCESSIBLE UNITS (w/ ROLL-IN SHOWER)	3A				1
TYPE-B HEARING/VISION IMPAIRED & ADAPTABLE UNITS			1B, 2B		2
TYPE-A UNITS			1A	2A	2
TYPE-B UNITS	1C, 2C, 3C 1D, 1E, 2D	1C, 2C, 3C 1D, 1E, 2D	1C, 2C, 3C 1D, 1E, 2D	1C, 2C, 3C 1D, 1E, 2D	85
TOTAL	22	25	25	22	94

1A,2A,3A - ACCESSIBLE & TYPE-A
1B,2B - HEARING & VISION
1C,2C,3C,1D,1E,2D - TYPE-B

B-A2.5 ENLARGED PUBLIC SPACE PLAN

A FOURTH FLOOR
3/32"=1'-0"

Architects Planners Designers
1861 Main Street, Suite 301
Kansas City, MO 64108
785.827.0386

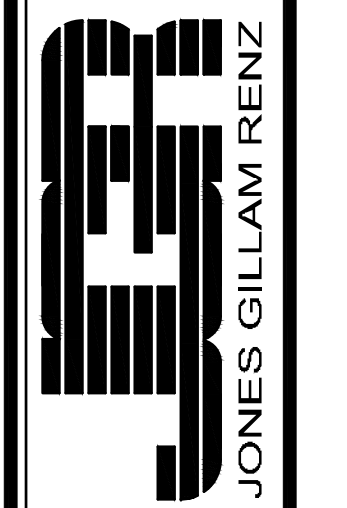

CLIFTON RIVERSIDE APARTMENTS
NEW APARTMENTS
FORT WORTH, TEXAS
JONES GILLAM RENZ
785.827.0386
jgr@jgarchitects.com



REVISION:

DATE: 1-28-2022

JOB: 21-3137

SHEET:

A2.4

COPYRIGHTED ©

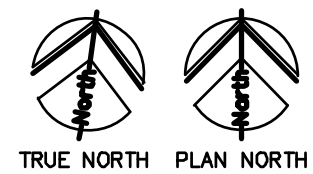
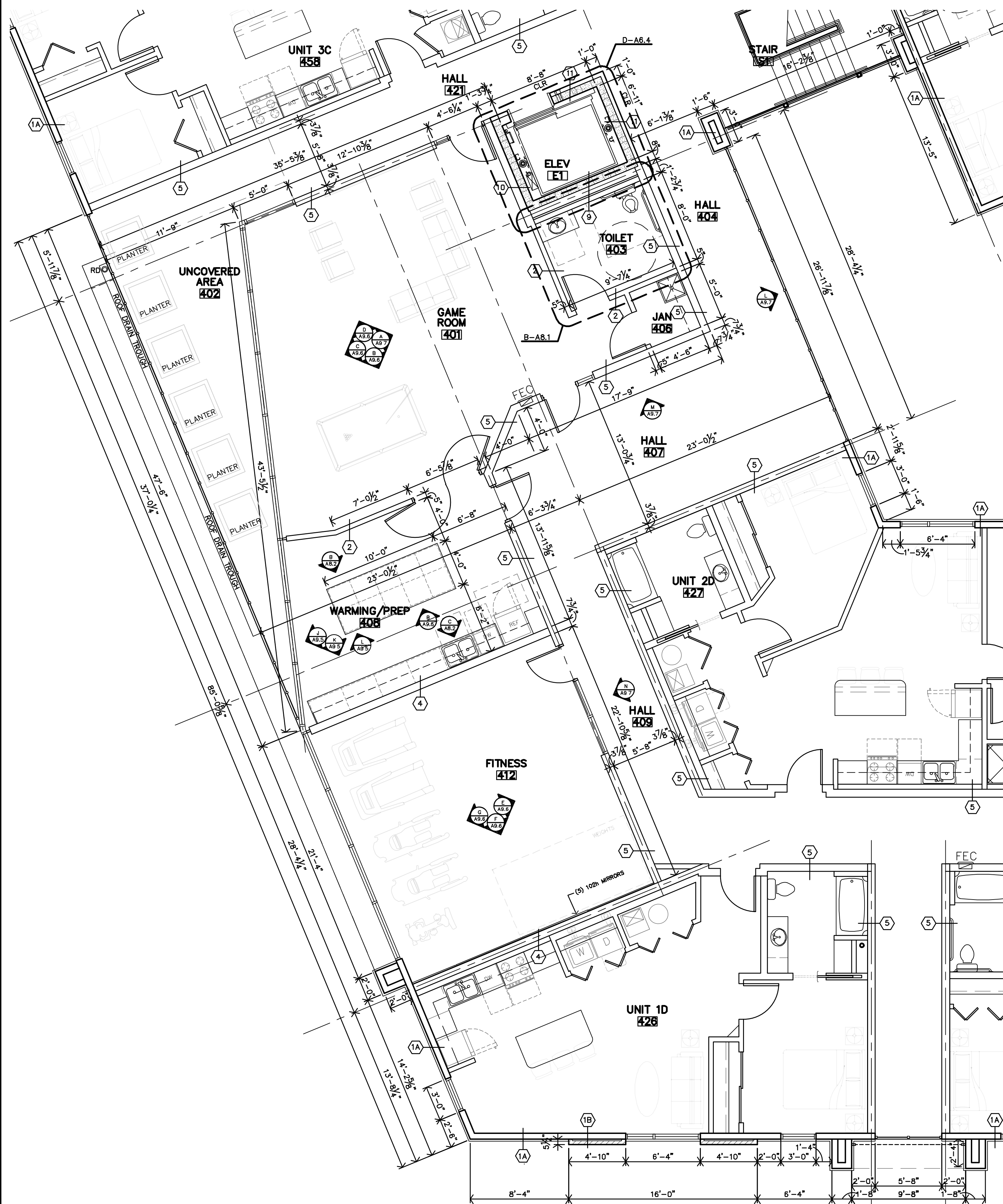

A ENLARGED FOURTH FLOOR PUBLIC SPACE
3/32"=1'-0"

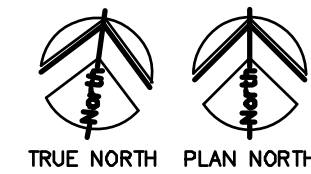

A ENLARGED FIRST FLOOR PUBLIC SPACE
3/32"=1'-0"



REVISION:	
DATE:	1-28-2022
JOB:	21-3137
SHEET:	

A2.5

COPYRIGHTED ©

CLIFTON RIVERSIDE APARTMENTS
NEW APARTMENTS
FORT WORTH, TEXAS

Architects Planners Designers
1861 Main Street, Suite 301
Kansas City, MO 64108
770 N. North
P.O. Box 2928
Salina, KS 67402
785.827.0386
jgr@jgarchitects.com

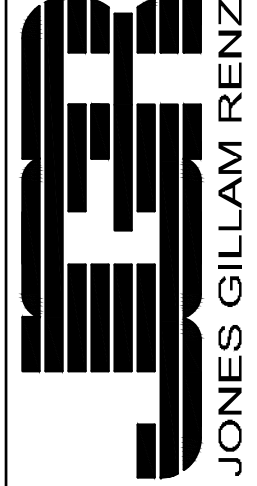

JONES GILLAM RENZ

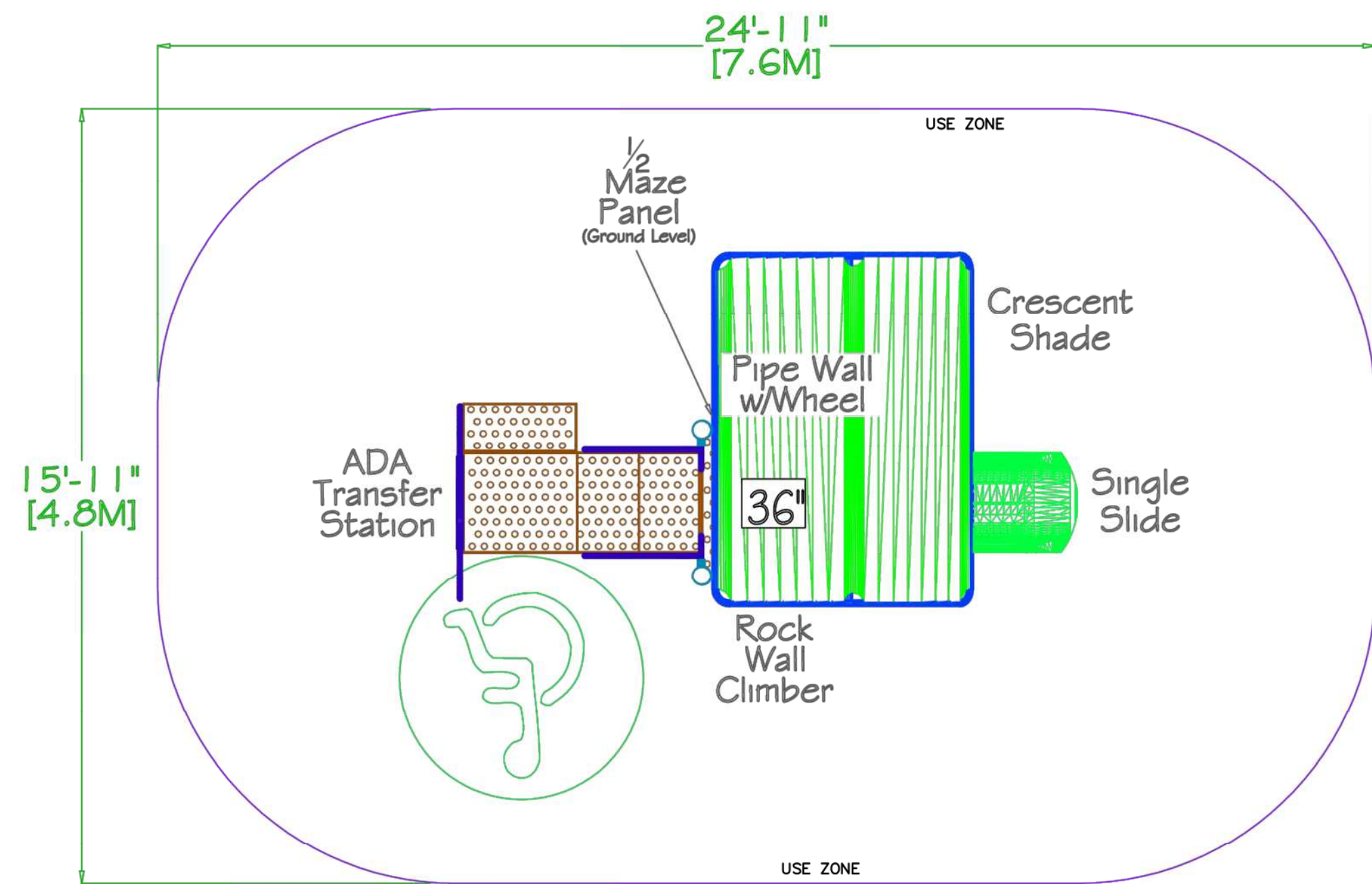

CUSTOM PLAY-GYM STRUCTURE SHOULD INCLUDE 4 PLAY COMPONENTS:
 1/2 MAZE PANEL
 ROCK WALL CLIMBER
 PIPE WALL WITH WHEEL AND SINGLE SLIDE
 SUITABLE FOR AGES 2-5
 (COLOR SCHEME TBD BY ARCHITECT/OWNER)

D CUSTOM PLAY-GYM SPECIFICATION PLAN
 NO SCALE

SuperiorPlaygrounds
 BY SUPERIOR RECREATIONAL PRODUCTS

REFERENCE NUMBER
 PS3-71323
 3.5" STEEL STRUCTURE DESIGN
 EQUIPMENT SIZE 13'X5' USE ZONE 25'X17'
 AGE GROUP 2-5 SURFACE AREA 381 S.F.

USER CAPACITY 4' TIMBER COUNT
 5-10 21

FALL HEIGHT
 3'

ADA ACCESSIBILITY

ELEVATED PLAY ACTIVITIES

	GROUND LEVEL ACCESSIBLE PLAY ACTIVITIES	GROUND LEVEL ACCESSIBLE ACTIVITY TYPES
REQUIRED	1	1
PROVIDED	1	1

THIS STRUCTURE MEETS OR EXCEEDS CPSC #325 AND ASTM F1487-17 UNLESS OTHERWISE NOTED.

DATE 4/30/2021 DRAWN/SAVED BY CK / CHRIS.KELLER
 SCALE 1/4" = 1'-0" SHEET 1 OF 2

PAGE

PLAN_VIEW

WE RECOMMEND THIS PLAN BE PRINTED ON 11" x 17" PAPER

PLAYGROUND SUPERVISION IS REQUIRED.
 THIS DESIGN IS THE PROPERTY OF SUPERIOR RECREATIONAL PRODUCTS AND MAY NOT BE REPRODUCED OR USED IN ANY MANNER WITHOUT THE EXPRESSED WRITTEN CONSENT OF SUPERIOR RECREATIONAL PRODUCTS.



C BBQ GRILL
 NO SCALE



B PICNIC TABLE
 NO SCALE



E CUSTOM PLAY-GYM
 NO SCALE

PLAYGROUND AREA TO HAVE PLAYSFAFER RUBBER MULCH FROM www.RUBBERCYCLE.com THAT MEETS ASTM F 1292-99/04, ASTM F 1487-01, ASTM F 1951-99 & PER MANUF. RECOMMENDATIONS.
 PLAYGROUND EDGING TO MATCH PARKURB BORDER FROM PLAYGROUND-EQUIPMENT.COM SHOULD BE DUG INTO GROUND SO THAT TOP OF EDGING IS FLUSH WITH SIDEWALK AND MULCH SURFACE TO MEET ACCESSIBILITY REQUIREMENTS.

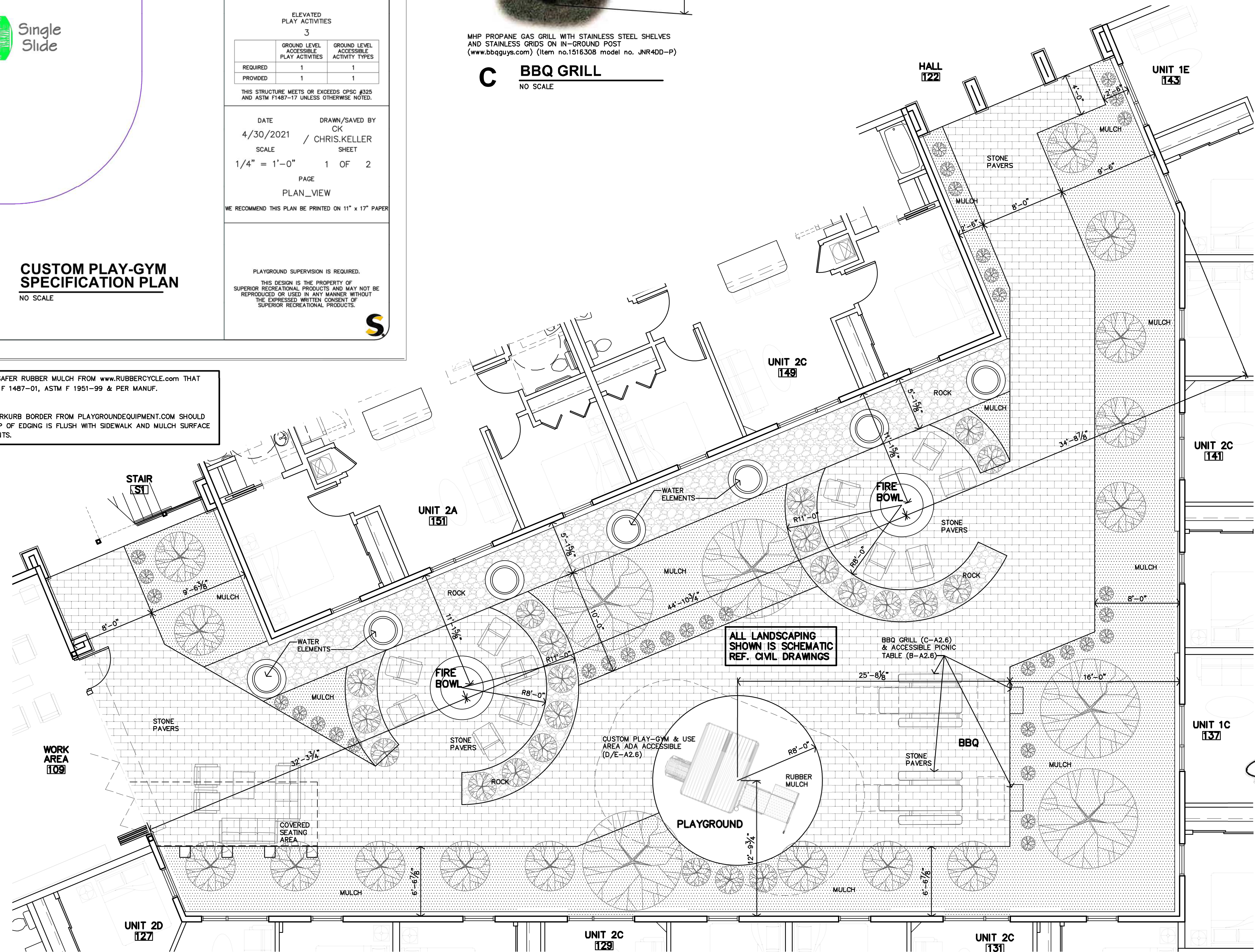

ALL LANDSCAPING SHOWN IS SCHEMATIC REF. CIVIL DRAWINGS

BBQ GRILL (C-A2.6) & ACCESSIBLE PICNIC TABLE (B-A2.6)

CUSTOM PLAY-GYM & USE AREA ADA ACCESSIBLE (D/E-A2.6)

PLAYGROUND

BBQ

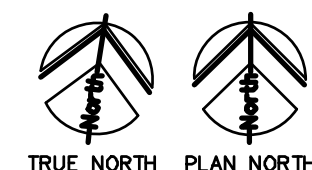

A COURTYARD PLAN
 3/16"=1'-0"

Architects Planners Designers
 1861 Main Street, Suite 301
 Kansas City, MO 64108
 770 N. North
 P.O. Box 2928
 Salina, KS 67402
 jgr@jgarchitects.com
 785.827.0386

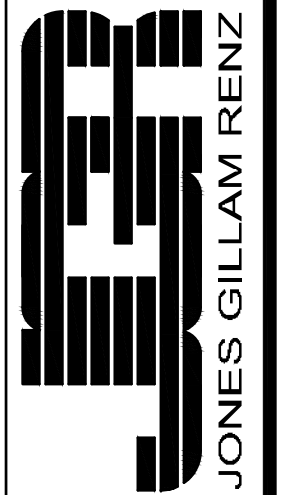

CLIFTON RIVERSIDE APARTMENTS
 NEW APARTMENTS
 FORT WORTH, TEXAS



REVISION:
 DATE: 1-28-2022
 JOB: 21-3137
 SHEET:

A2.6

COPYRIGHTED ©

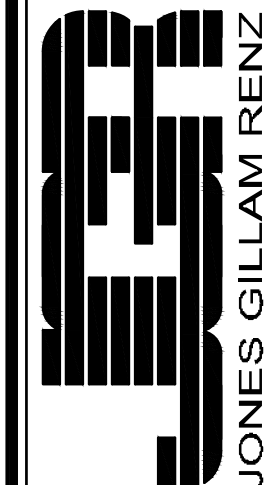

APARTMENT GENERAL NOTES

- REF STRUCTURAL DRAWINGS FOR SHEAR WALL LOCATIONS.
- TYPICAL GROUND FLOOR FINISH FLOOR ELEVATION IS REFERENCED AS 100'-0". CONTRACTOR SHALL VERIFY BUILDING ELEVATION WITH SITE CIVIL DRAWINGS.
- REFERENCE SITE PLAN SHEET A1.1 FOR LOCATION & ORIENTATION OF BUILDING.
- CONTRACTOR SHALL PROVIDE PLASTIC COATED WIRE SHELVES & ROD AT ALL CLOSETS U.N.O.
- CONTRACTOR SHALL PROVIDE BLOCKING, ANCHOR BOLTS AND ANY REQUIRED SHEAR WALL BLOCKING AS REQUIRED BY STRUCTURAL DRAWINGS.
- CONTRACTOR TO PROVIDE FIRE BLOCKING AT PARTY WALL AT 10'-0" O.C. VERT. & HORIZ. TYP., AND AT ALL BACK TO BACK ELECTRICAL OUTLETS. PROVIDED AND INSTALL ALL FIRE BLOCKING AND DRAFTSTOPS PER 2015 IBC, SECTION 708 & 718.
- FIRE EXTINGUISHERS SHALL BE INSTALLED & PROVIDED IN ACCORDANCE WITH NFPA 10 & 2015 IBC, SECTION 906.1. LOCATED PER CFP SHEET.
- ALL PENETRATIONS THRU RATED WALLS AND/OR FLOOR ASSEMBLIES SHALL BE FIRESTOPPED PER APPROVED U.L. DESIGNS. REFERENCE SHEET A4.7 FOR FIRE PENETRATION ASSEMBLIES.
- HOSE BIBS TO BE LOCATED 6" MIN. ABOVE WAINSCOT (30" MIN. ABV. FIN. FLOOR).
- TYPICAL AT UNIT WINDOWS, BOTTOM OF HEADER IS 80" ABV. FIN. FLR. STRUCT.
- KITCHEN RECEPTACLES TO BE 44" MAX ABOVE FIN. FLR.
- SUBMIT VERIFICATION THAT ALL CONSTRUCTION MATERIAL WILL MEET US EPA CRITERIA PARTICULARLY MATERIALS THAT WILL BE OBTAINED FROM INTERNATIONAL SOURCES. ALSO PROVIDE VERIFICATION THAT THE CONSTRUCTION WILL NOT RESULT IN OR CONTAIN HAZARDOUS MATERIALS.
- ALL INTERIOR WALL DIMENSIONS ARE TO FACE OF CYP. BD. UNLESS NOTED OTHERWISE.
- HEARING/VISION IMPAIRED UNIT (WHERE LISTED ON SHEET A1.1 AND INDICATED ON BUILDING PLANS):
 • CONTRACTOR SHALL PROVIDE & INSTALL EQUIPMENT REQUIRED PER 2010 ADA SEC. 308.5.
 • REF. ELEC. DWGS
- FE = WALL MOUNTED FIRE EXTINGUISHER REF. SPECIFICATIONS.
- REF. SHEET A2.0 & A2.7 FOR PARTITION SCHEDULE.
- DOORS ARE TYPICALLY LOCATED 4" FROM CORNER U.N.O.
- F.O.S. = FACE OF STUD

ADAPTABLE UNIT NOTES

- ADAPTABLE UNITS (WHERE LISTED ON SHEET A1.1 AND INDICATED ON BUILDING PLANS):
 • REFERENCE ENLARGED PLANS AND DETAILS FOR ADDITIONAL INFORMATION
 • 1-BEDROOM, CONTRACTOR TO PROVIDE & INSTALL REMOVABLE CABINET & 2x8 BLOCKING IN WALLS FOR FUTURE GRAB BARS @ ALL TOILETS, TUBS AND COUNTERTOPS.
 • 2-BEDROOM, CONTRACTOR TO PROVIDE & INSTALL REMOVABLE CABINETS AT BATH #4, #11 & KITCHEN #3. PROVIDE & INSTALL 2x8 BLOCKING IN WALLS FOR FUTURE GRAB BARS @ TOILET, TUB & COUNTERTOP AT BATHS #4 & #11.
 • 3-BEDROOM, CONTRACTOR TO PROVIDE & INSTALL REMOVABLE CABINETS AT BATH #4, #11 & KITCHEN #3. PROVIDE & INSTALL 2x8 BLOCKING IN WALLS FOR FUTURE GRAB BARS @ TOILET, TUB & COUNTERTOP AT BATHS #4 & #11.
 • ALL UNITS, CONTRACTOR TO INSTALL REMOVABLE CABINET FRONTS @ SINK & WORK SPACE IN KITCHEN #3.
 - AT ALL REMOVABLE CABINETS, FLOORS & WALLS SHALL BE FINISHED. NO PLUMBING MODIFICATIONS ALLOWED AFTER CABINET FRONT IS REMOVED.
 CONTRACTOR SHALL PROVIDE HOT WATER & DRAIN PIPES COVERS. OWNER SHALL INSTALL COVER AFTER CABINET FRONT IS REMOVED.
 - TOILETS SHALL BE ACCESSIBLE COMPLIANT (17"-19" HIGH).
 - CONTRACTOR TO INSTALL 2x8 BLOCKING PER ICC/ANSI A117.1.-2009

ACCESSIBLE UNIT NOTES

- ACCESSIBLE UNITS (WHERE LISTED ON SHEET A1.1 AND INDICATED ON BUILDING PLANS):
 • REFERENCE ENLARGED PLANS AND DETAILS FOR ADDITIONAL INFORMATION
 • 1-BEDROOM, CONTRACTOR TO PROVIDE & INSTALL 2x8 BLOCKING IN WALLS FOR GRAB BARS @ ALL TOILETS, TUBS AND COUNTERTOPS.
 • 2-BEDROOM, CONTRACTOR TO PROVIDE & INSTALL 2x8 BLOCKING IN WALLS FOR GRAB BARS @ TOILET, TUB & COUNTERTOP AT BATHS #4 & #11.
 • 3-BEDROOM, CONTRACTOR TO PROVIDE & INSTALL 2x8 BLOCKING IN WALLS FOR GRAB BARS @ TOILET, TUB & COUNTERTOP AT BATHS #4 & #11.
 • ALL UNITS, - CONTRACTOR SHALL PROVIDE & INSTALL INSULATED COVERS @ ALL EXPOSED HOT WATER PIPES, DRAIN PIPES & DISPOSAL.
 - TOILETS SHALL BE ACCESSIBLE COMPLIANT (17"-19" HIGH).
 - CONTRACTOR TO INSTALL 2x8 BLOCKING PER ICC/ANSI A117.1.-2009

EXTERIOR PARTITION SCHEDULE

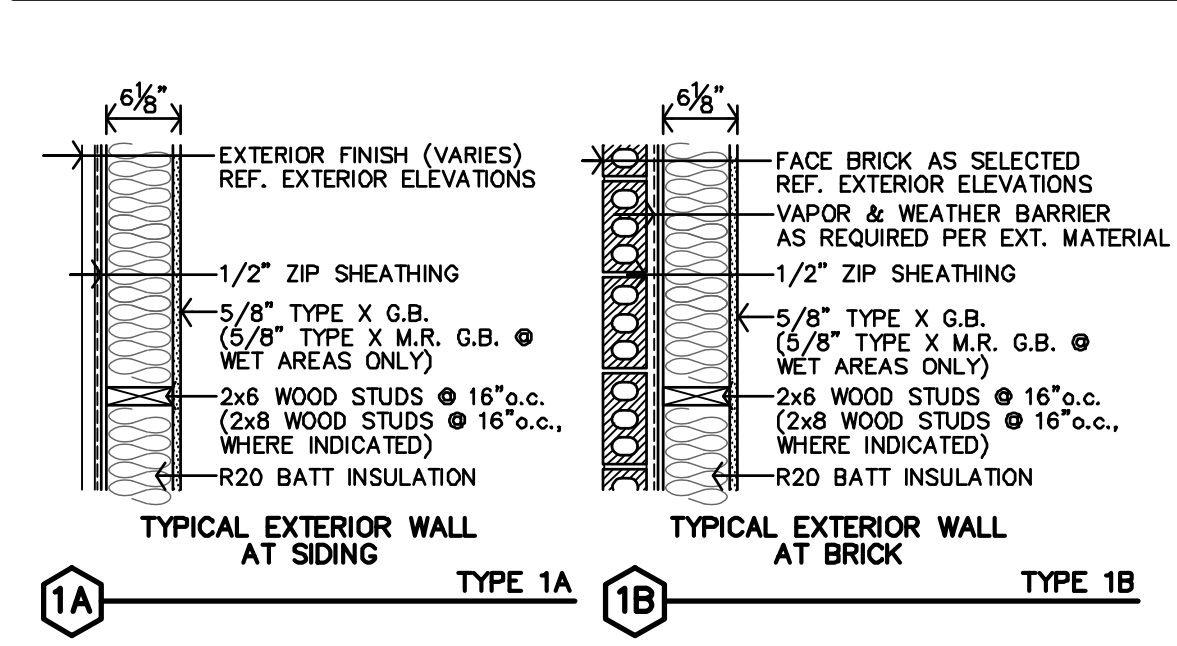

INTERIOR PARTITION SCHEDULE

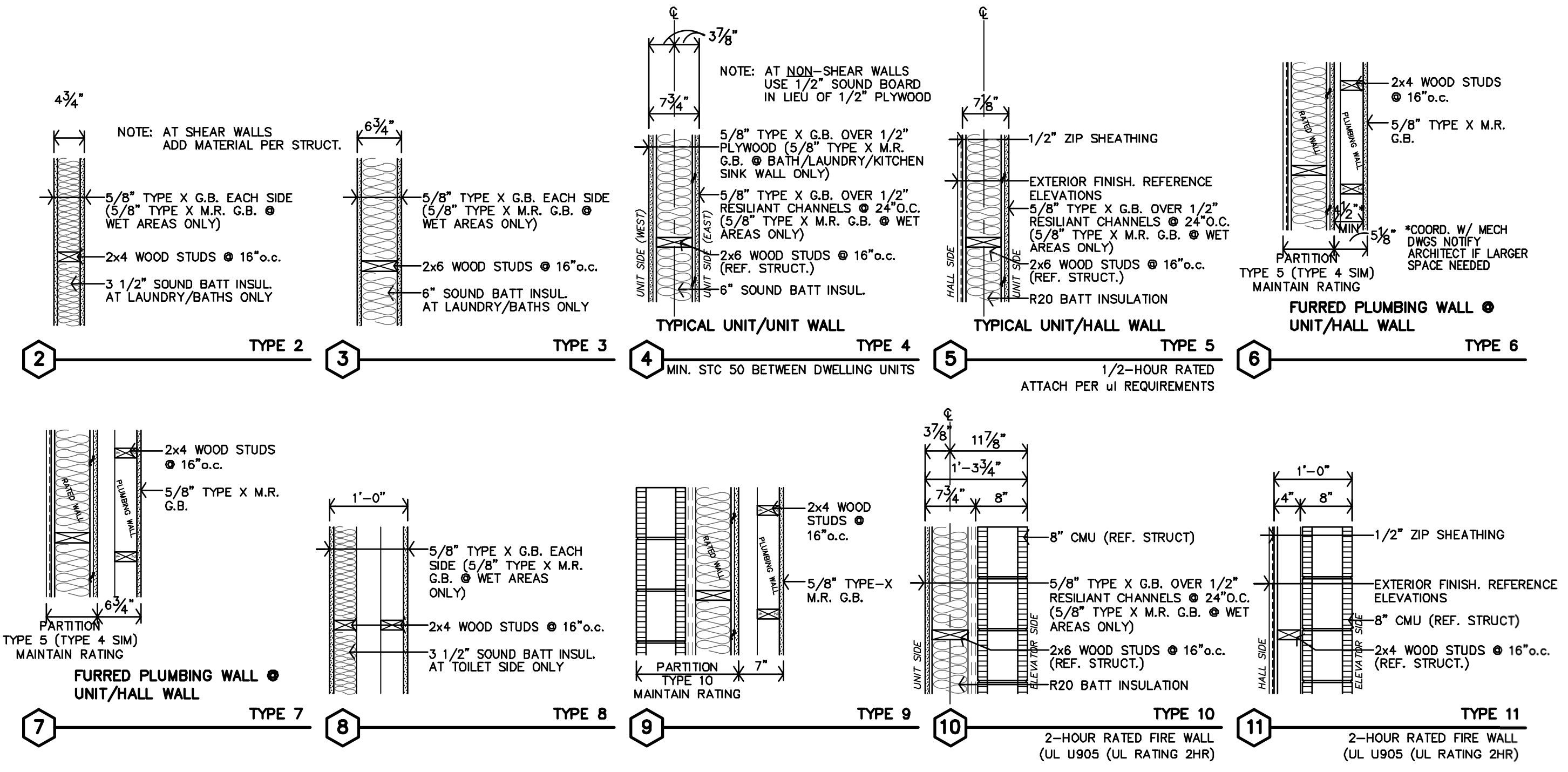

UNIT ACCESSIBLE BATH DETAILS

P TYP. HEIGHTS @ ACCESSIBLE TUB CONTROL WALL
 1/4"=1'-0" FOR ACCESSIBLE HEIGHTS

O TYP. HEIGHTS @ ACCESSIBLE TUB BACK WALL
 1/4"=1'-0" FOR ACCESSIBLE HEIGHTS

N TYP. HEIGHTS @ ACCESSIBLE TUB HEAD WALL
 1/4"=1'-0" FOR ACCESSIBLE HEIGHTS

M TYP. HEIGHTS @ ACCESSIBLE TUB PLAN
 1/4"=1'-0" FOR ACCESSIBLE HEIGHTS

L TYP. HEIGHTS @ ACCESSIBLE ROLL-IN SHOWER CONTROL WALL
 1/4"=1'-0" FOR ACCESSIBLE HEIGHTS

K TYP. HEIGHTS @ ACCESSIBLE ROLL-IN SHOWER BACK WALL
 1/4"=1'-0" FOR ACCESSIBLE HEIGHTS

J TYP. HEIGHTS @ ACCESSIBLE ROLL-IN SHOWER PLAN
 1/4"=1'-0" FOR ACCESSIBLE HEIGHTS

H TYP. HEIGHTS @ ACCESSIBLE SHOWER CONTROL WALL
 1/4"=1'-0" FOR ACCESSIBLE HEIGHTS

G TYP. HEIGHTS @ ACCESSIBLE TRANSFER SHOWER BACK WALL
 1/4"=1'-0" FOR ACCESSIBLE HEIGHTS

F TYP. HEIGHTS @ ACCESSIBLE TRANSFER SHOWER PLAN
 1/4"=1'-0" FOR ACCESSIBLE HEIGHTS

E SHOWER SEAT
 1/2"=1'-0"

D TYP. HEIGHTS @ ACCESSIBLE TOILET SIDE WALL
 1/4"=1'-0" FOR ACCESSIBLE HEIGHTS

C TYP. HEIGHTS @ ACCESSIBLE TOILET REAR WALL
 1/4"=1'-0" FOR ACCESSIBLE HEIGHTS

APARTMENT CHART

TYPE OF APARTMENT	1ST FLOOR	2ND FLOOR	3RD FLOOR	4TH FLOOR	TOTAL
ACCESSIBLE UNITS (w/ REMOVABLE TUB SEAT)	2A	1A, 2A		1A	4
ACCESSIBLE UNITS (w/ ROLL-IN SHOWER)	3A				1
TYPE-B HEARING/VISION IMPAIRED & ADAPTABLE UNITS			1B, 2B		2
TYPE-A UNITS			1A	2A	2
TYPE-B UNITS	1C, 2C, 3C 1D, 1E, 2D	1C, 2C, 3C 1D, 1E, 2D	1C, 2C, 3C 1D, 1E, 2D	1C, 2C, 3C 1D, 1E, 2D	85
TOTAL	22	25	25	22	94

1A,2A,3A - ACCESSIBLE & TYPE-A
 1B,2B - HEARING & VISION
 1C,2C,3C,1D,1E,2D - TYPE-B



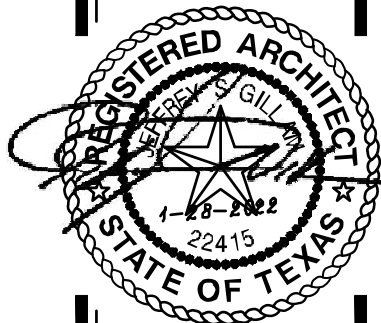

REVISION:	
DATE:	1-28-2022
JOB:	21-3137
SHEET:	A2.8

COPYRIGHTED ©

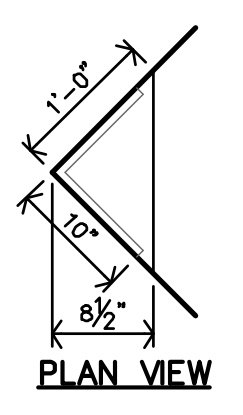
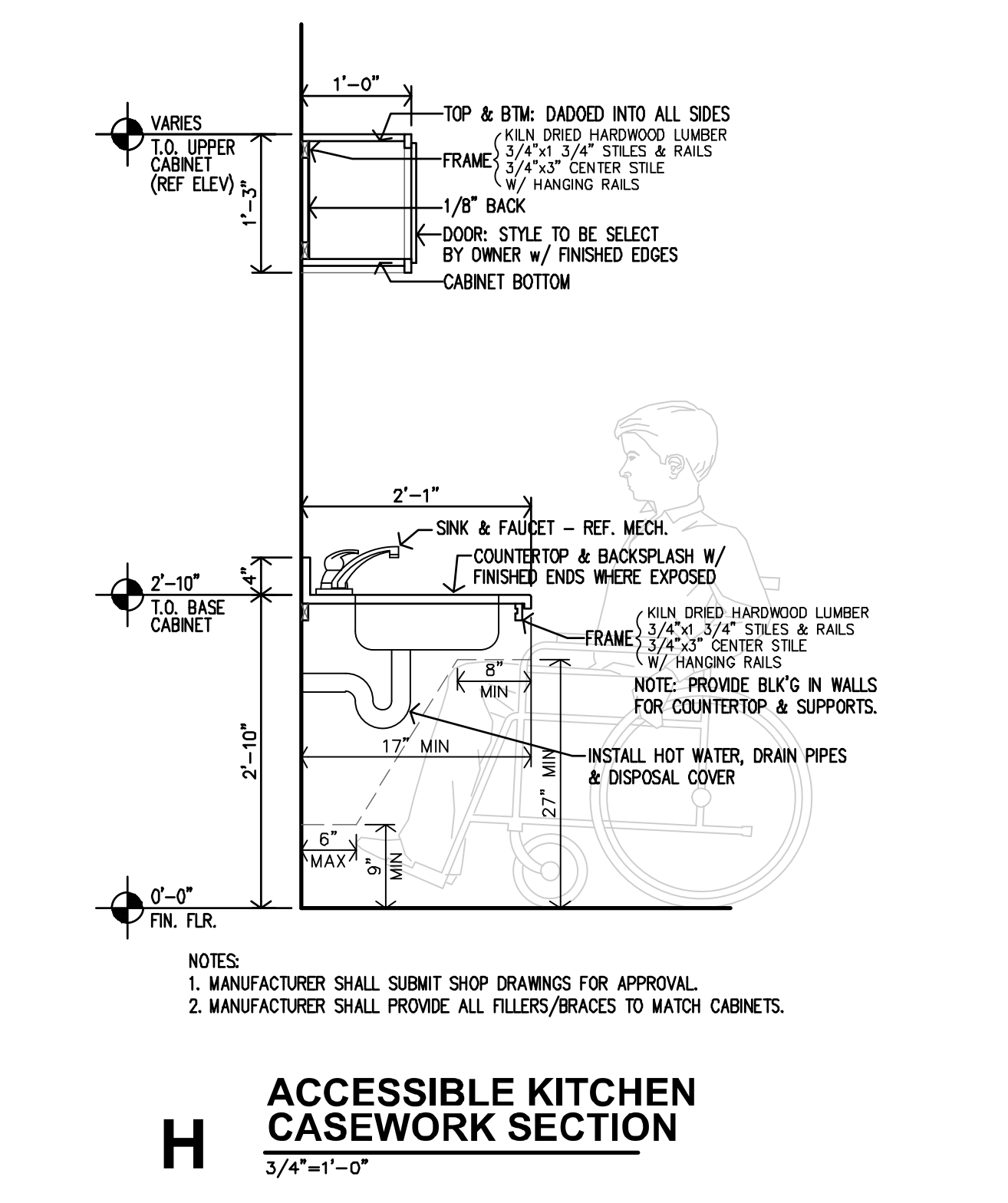
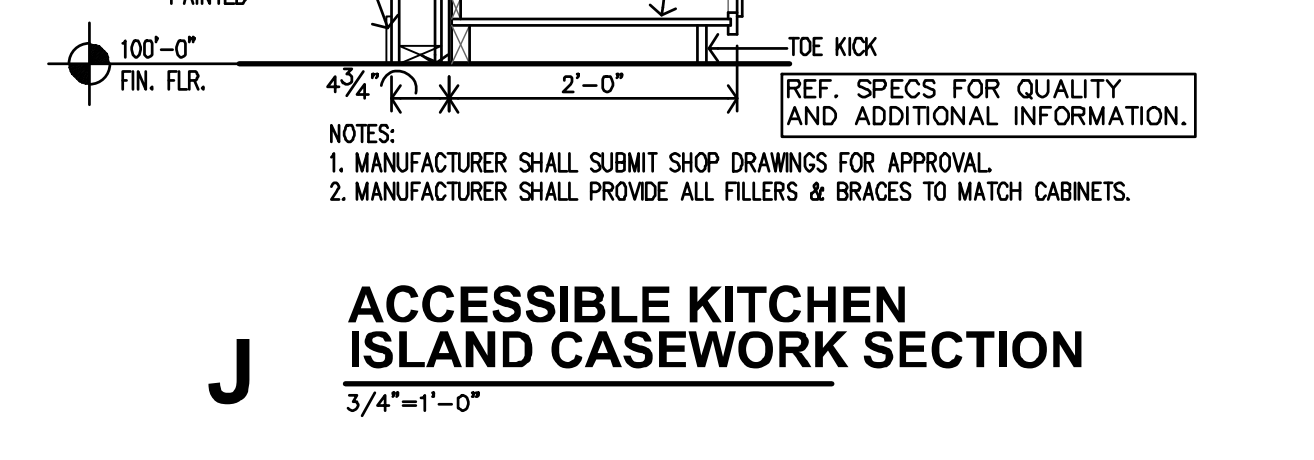
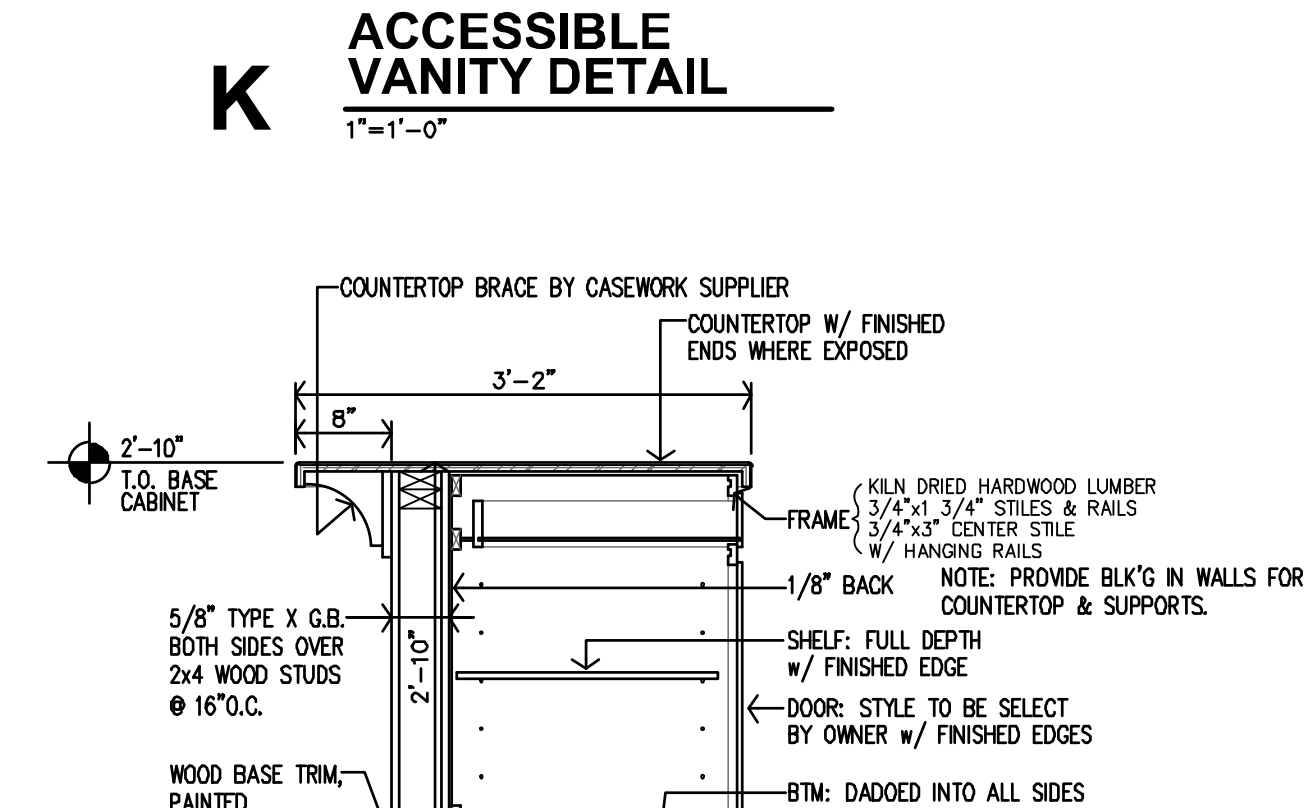
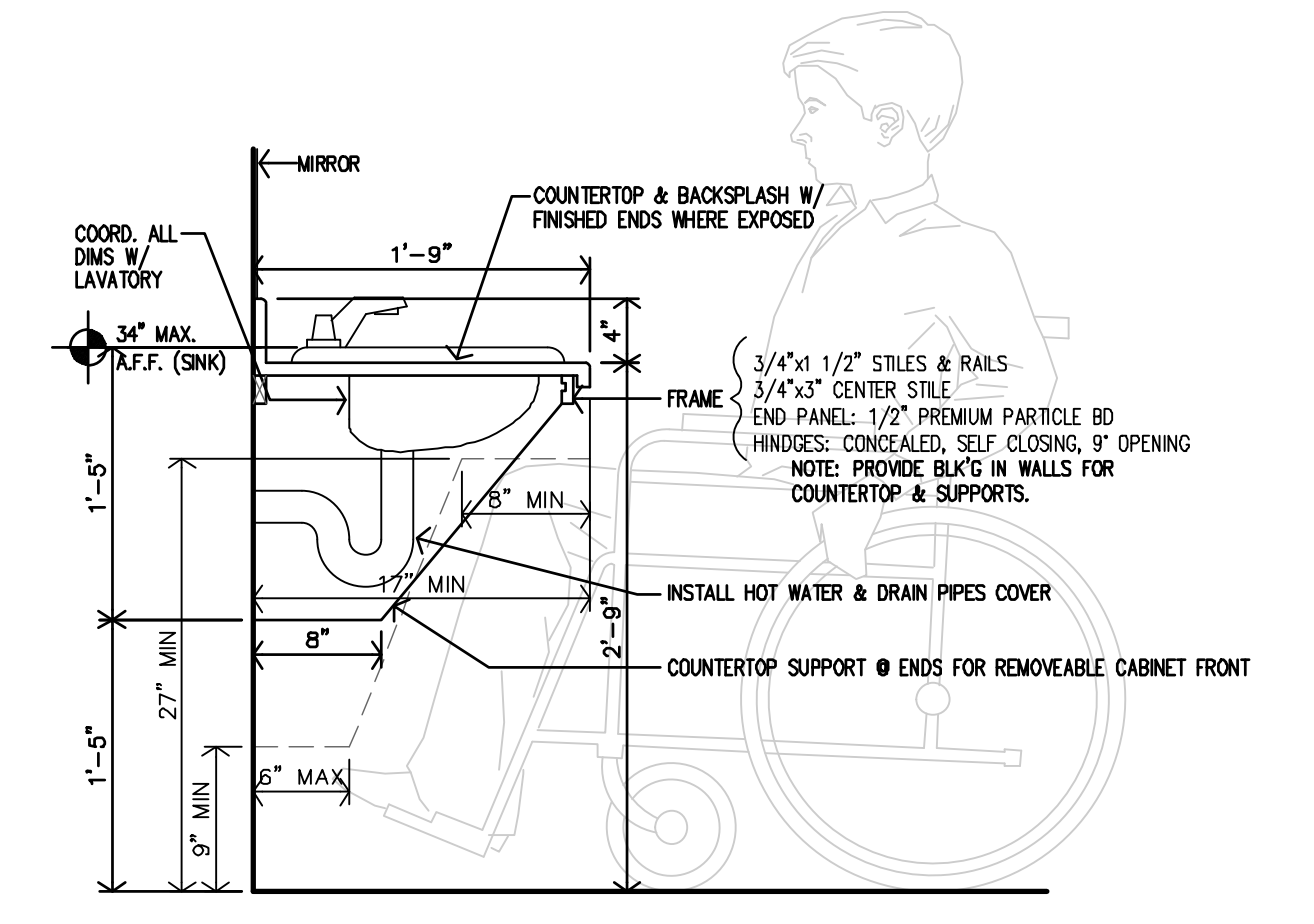
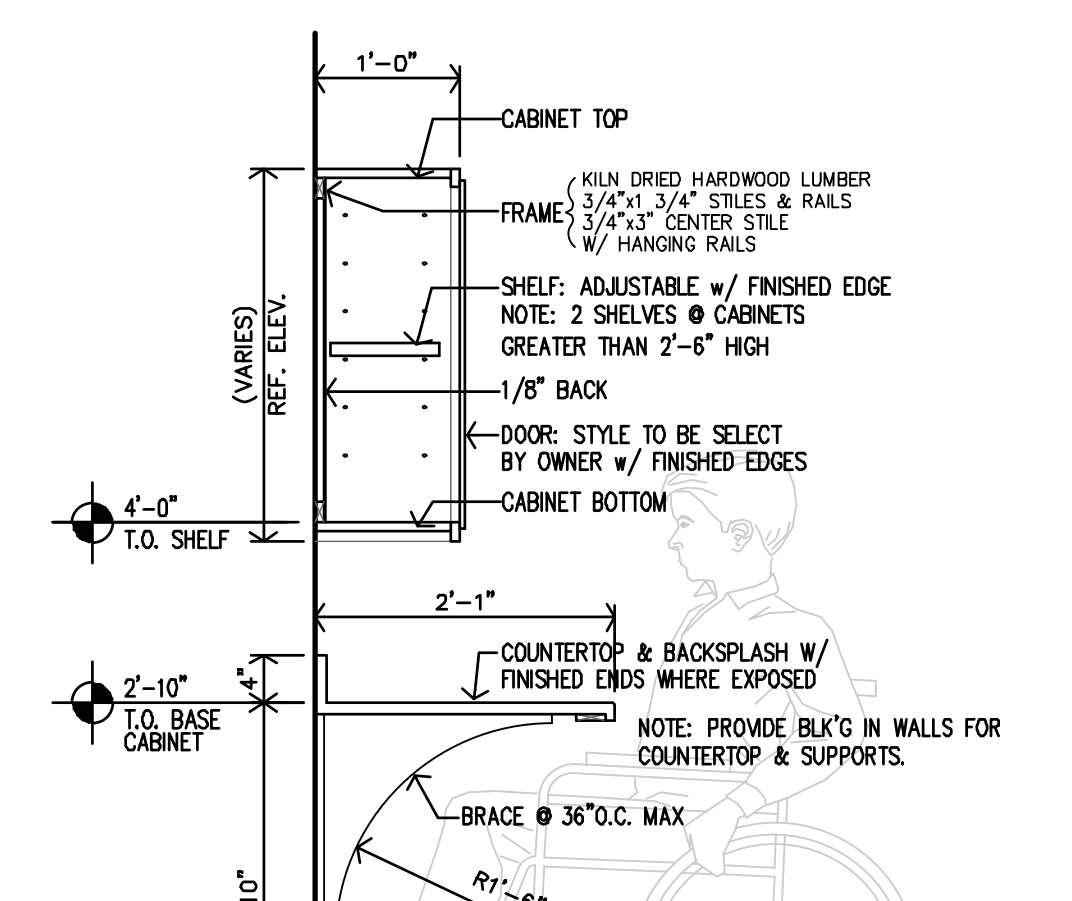
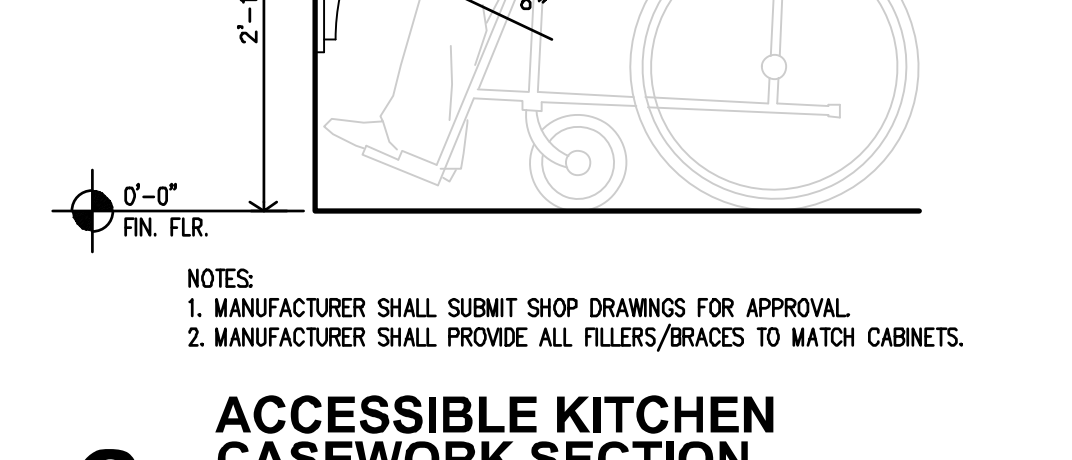
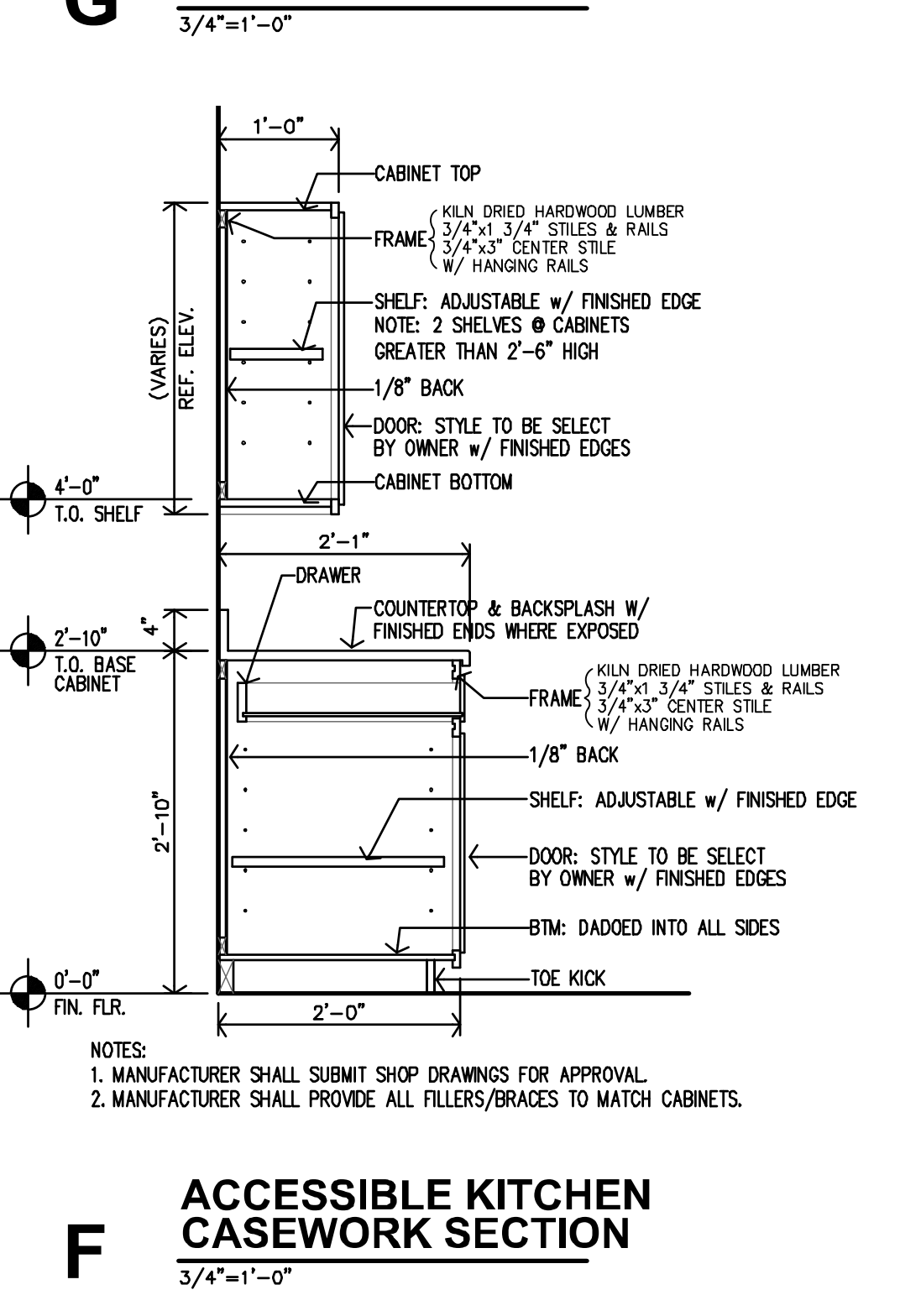
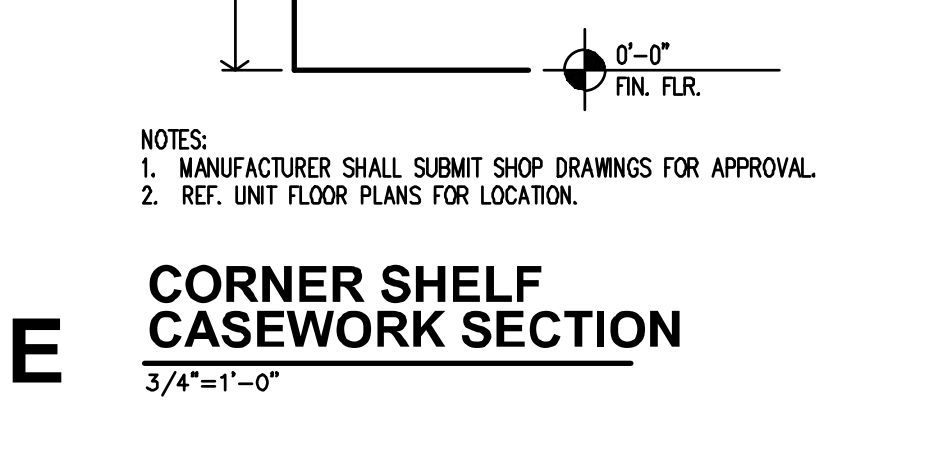
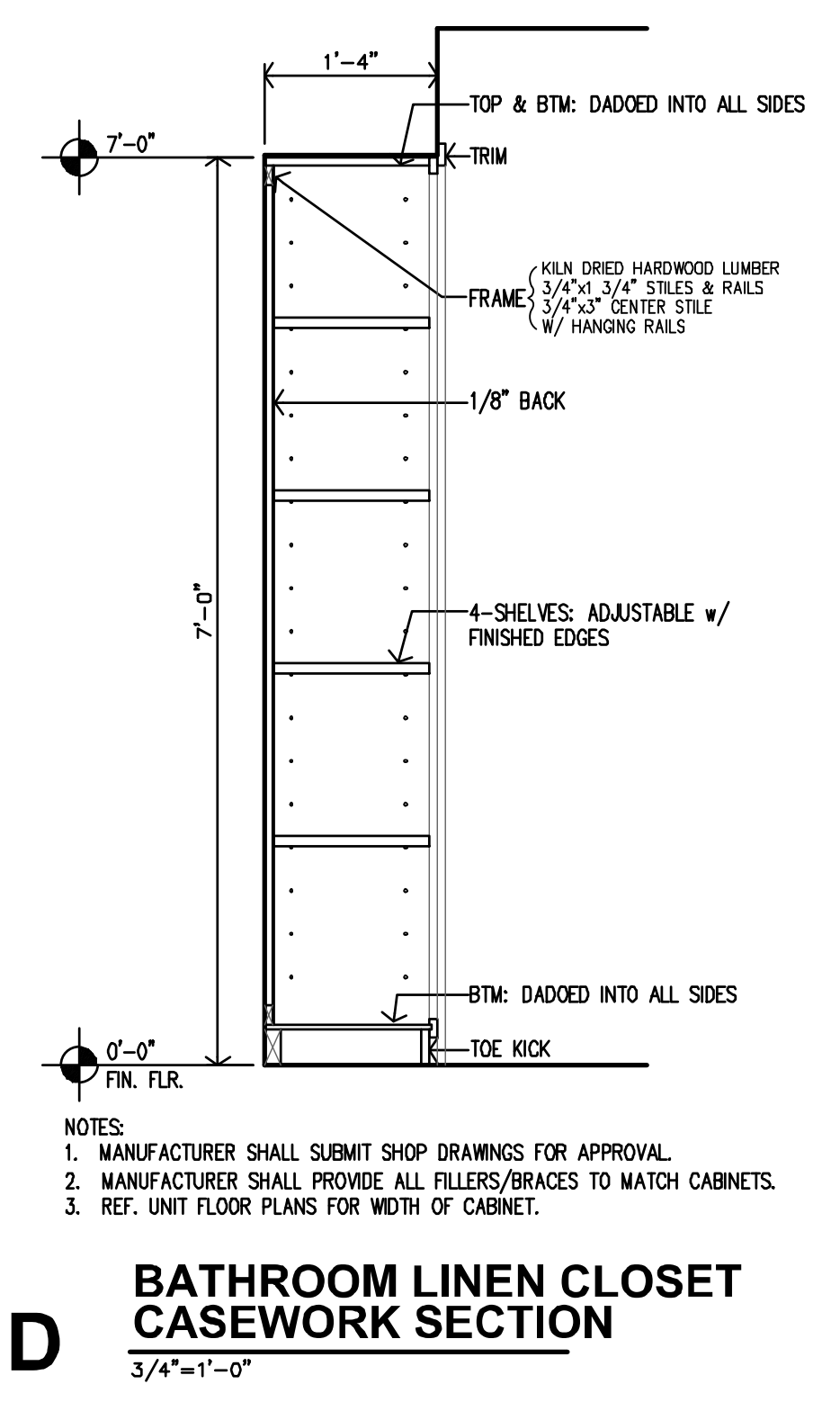
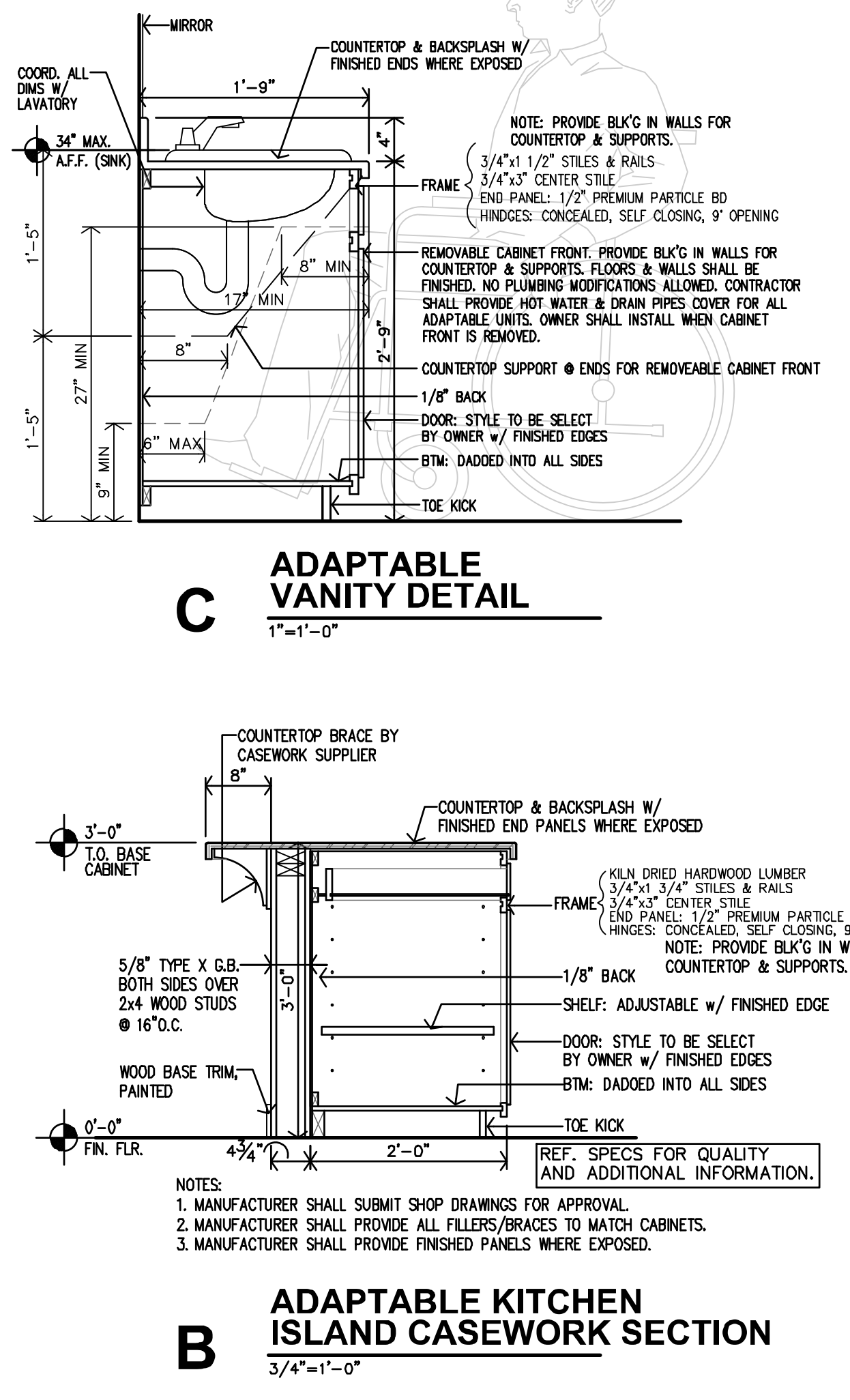
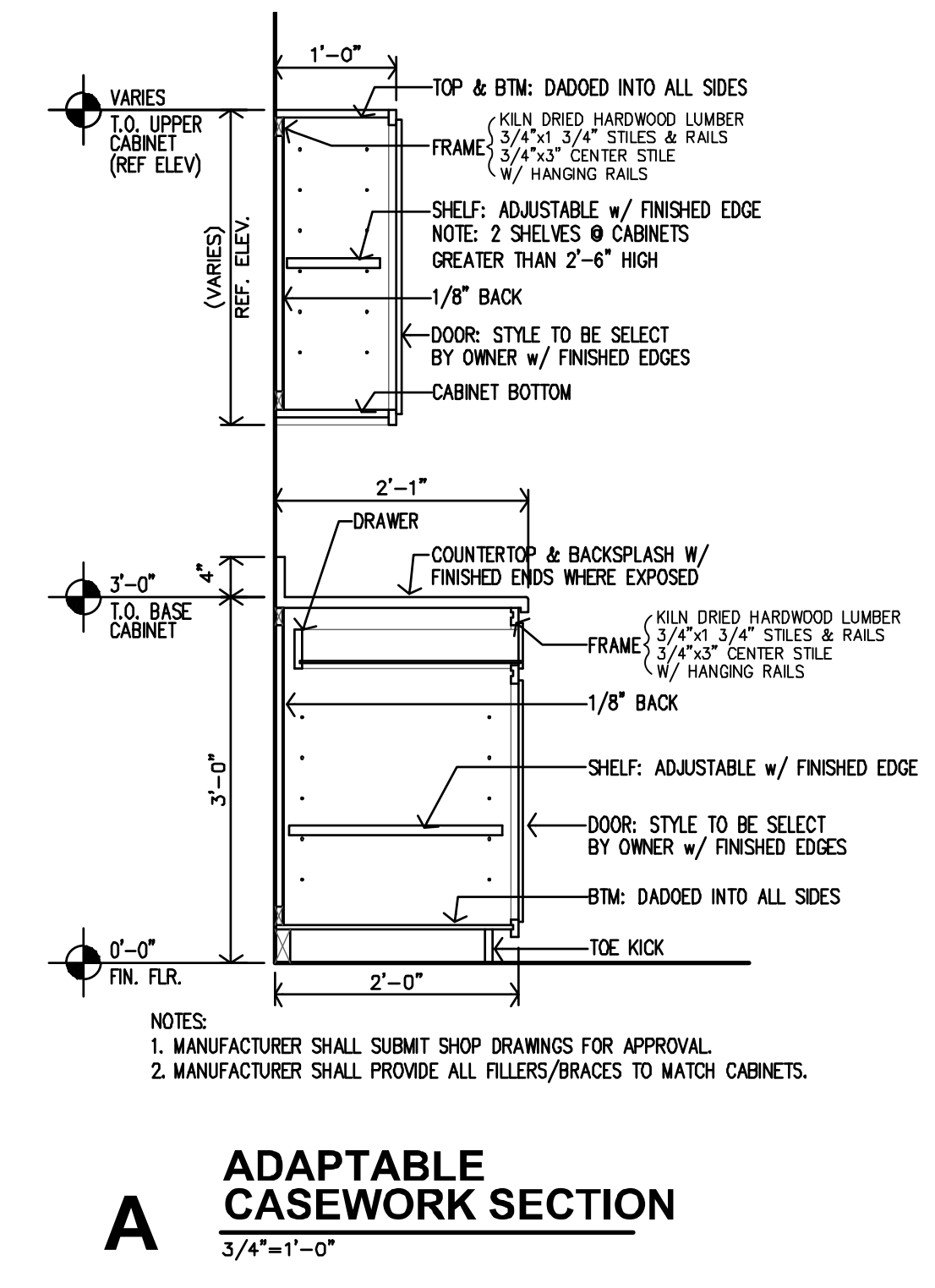



REVISION:	
DATE:	1-28-2022
JOB:	21-3137
SHEET:	

ADAPTABLE BATH NOTES	
1. REF APARTMENT GENERAL & ADAPTABLE UNIT NOTES ON SHEET A2.7 FOR ADDITIONAL DIRECTION.	
2. ALL DIMENSIONS ARE TO FACE OF GYP. BD. UNLESS NOTED OTHERWISE	
3. CONTRACTOR TO INSTALL 2x8 BLOCKING IN WALLS FOR ALL WALL MOUNTED/SUPPORTED COUNTERTOPS & BRACES, SHOWER UNIT, SLIDE BAR, TOWEL BARS, FUTURE GRABS BARS & FUTURE SHOWER SEAT, ETC. AS REQ'D. (REF. A2.7)	
4. SHOWER SEAT TO BE INSTALLED PER TENANT REQUEST IN ADAPTABLE UNITS.	
5. LOCATION OF WASHER & DRYER IS CRITICAL. WASHER IS TO BE LEFT OF DRYER, ALWAYS. THIS NEEDS TO BE COORDINATED ON SITE. ADAPTABLE & STANDARDS UNITS DESIGNED AROUND 27x42 WASHER & DRYER.	
6. F.O.S. = FACE OF STUD	

LEGEND	KEYNOTES:
M MIRROR	A PLASTIC COATED WIRE CLOTHES SHELF & ROD (HEIGHT AS CALLED OUT ON PLAN)
TP TOILET PAPER DISPENSER	B FLOORING TO BE CONTINUOUS @ REMOVABLE CABINETS
TB TOWEL BAR	C VERIFY SIZE w/ SHOWER UNIT
CL CORNER LEDGE	D WATER HEATER - REF. MECH. DRAWINGS
SR SHOWER ROD	

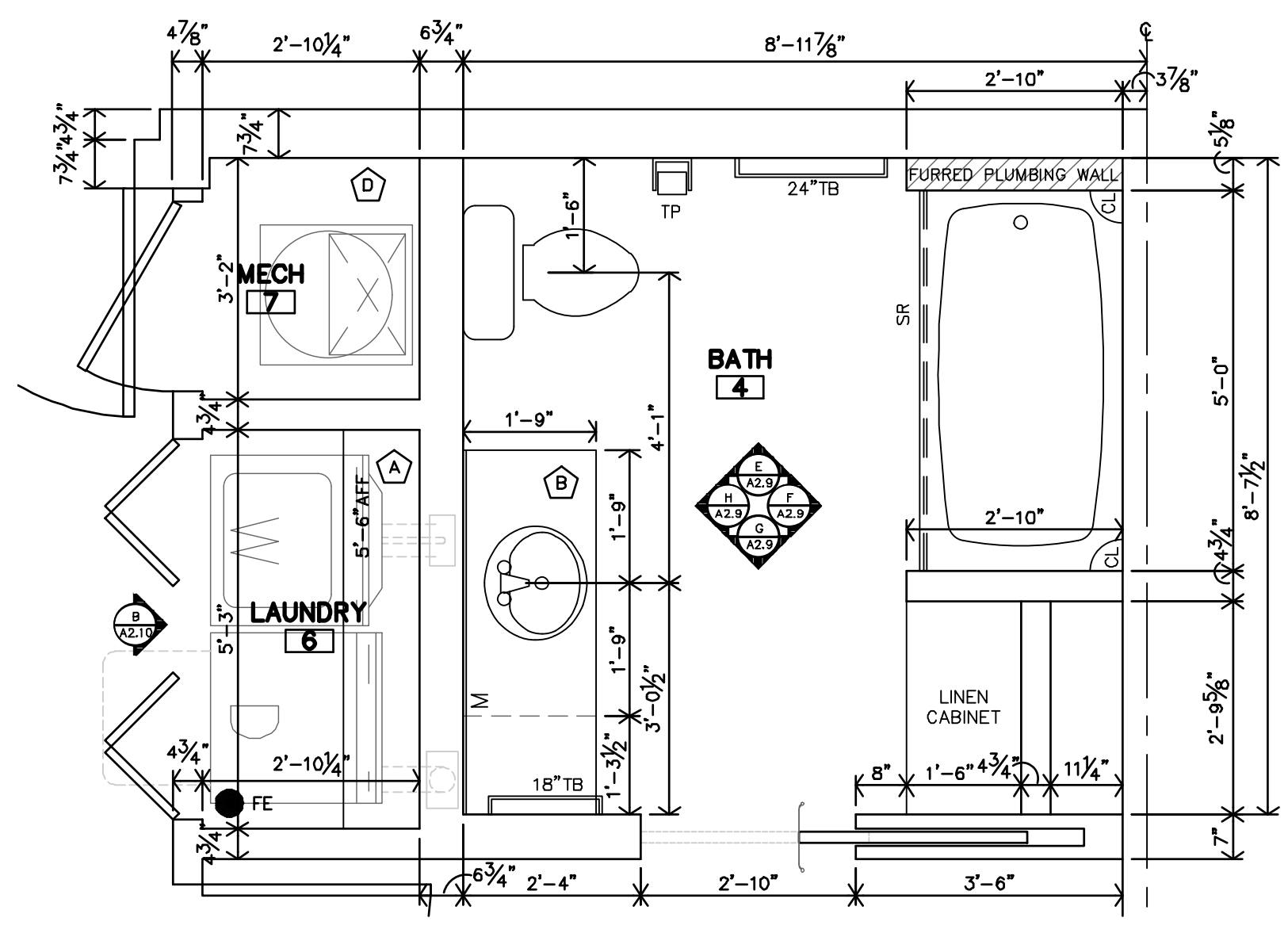

D 1 BEDROOM - 1 BATH ADAPTABLE ENLARGED BATHROOM PLAN
 1/2"=1'-0" UNITS: 1B, 1C-SAME, 1D-SAME, 1E-SIMILAR ROTATED

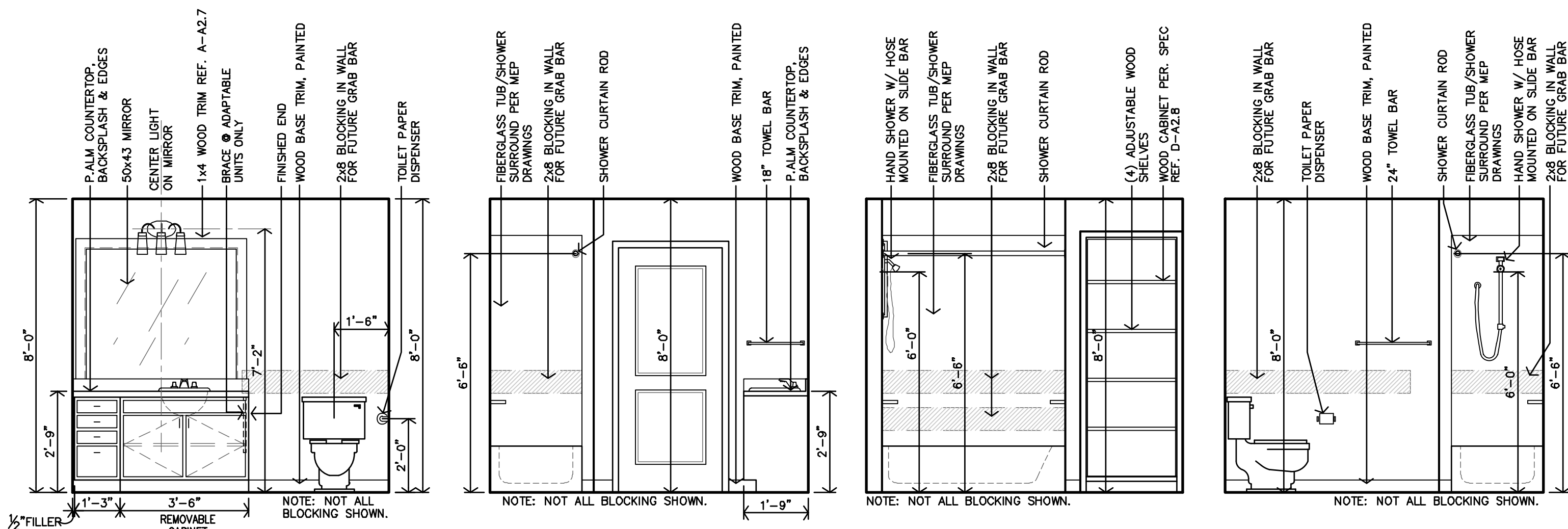

H BATH #4 INTERIOR ELEV. 3/8"=1'-0"
G BATH #4 INTERIOR ELEV. 3/8"=1'-0"
F BATH #4 INTERIOR ELEV. 3/8"=1'-0"
E BATH #4 INTERIOR ELEV. 3/8"=1'-0"

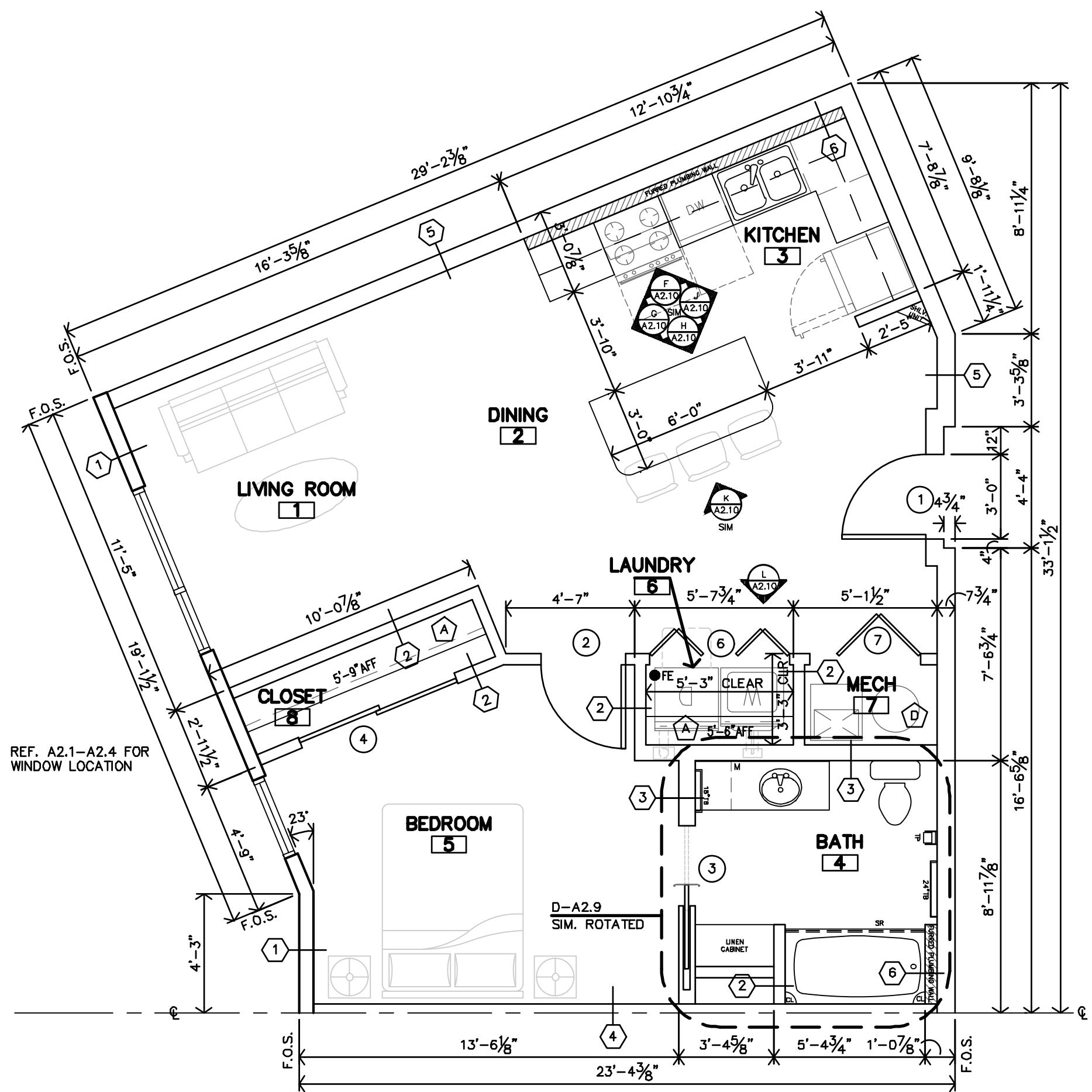

C UNIT 1E ADAPTABLE 1 BEDROOM - 1 BATH UNIT PLAN
 1/4"=1'-0"

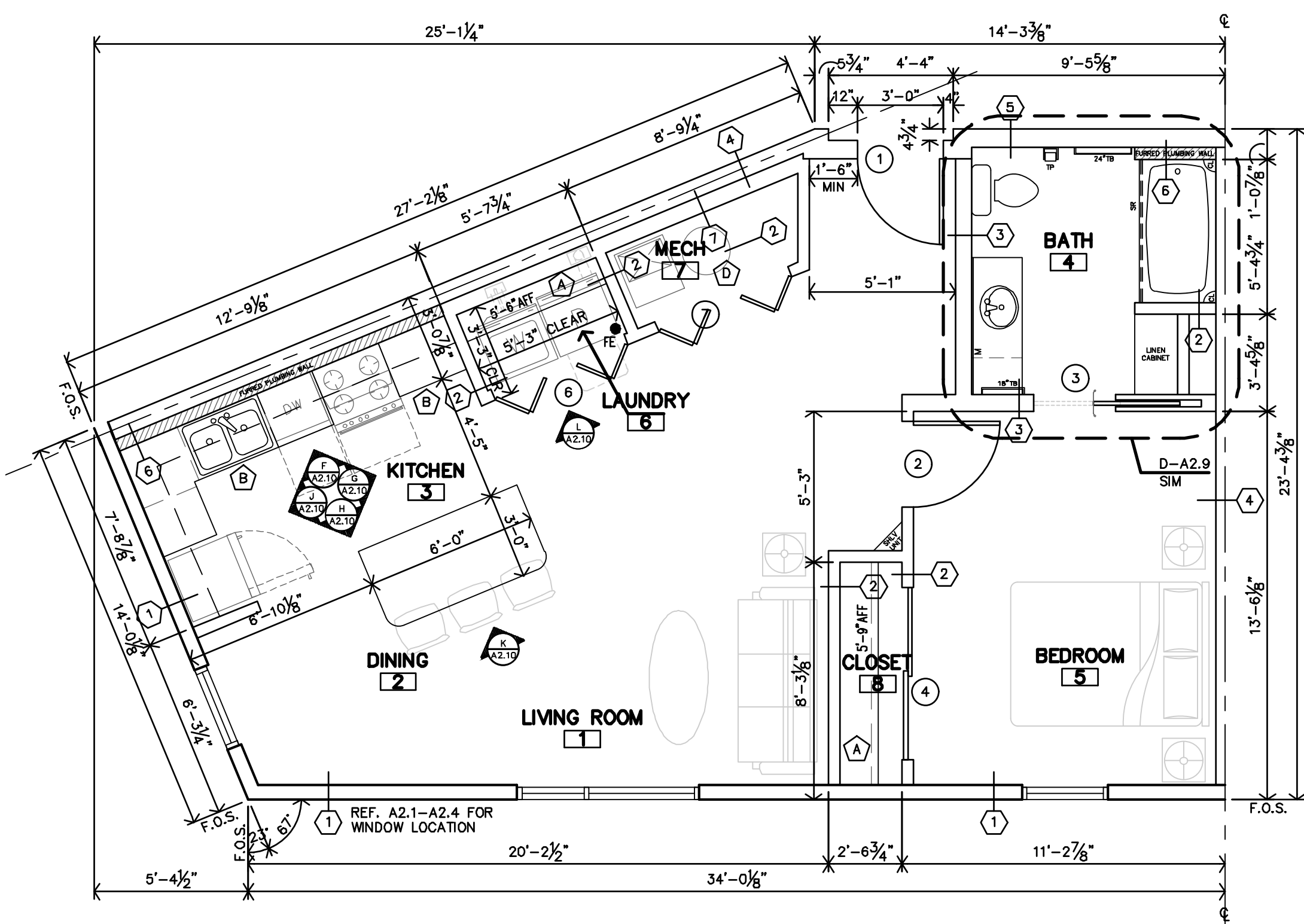

B UNIT 1D ADAPTABLE 1 BEDROOM - 1 BATH UNIT PLAN
 1/4"=1'-0"

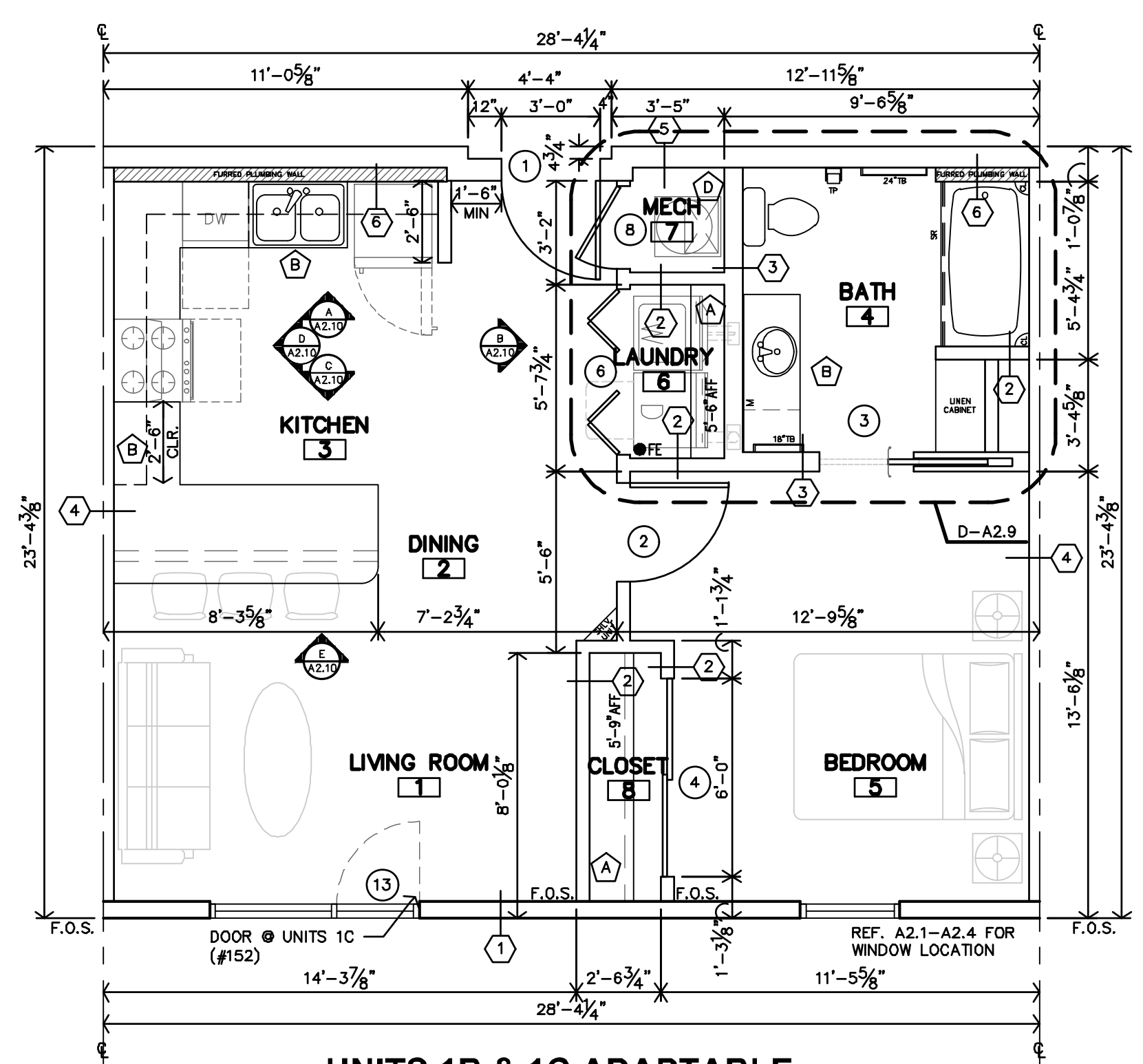

A UNITS 1B & 1C ADAPTABLE 1 BEDROOM - 1 BATH UNIT PLAN
 1/4"=1'-0"

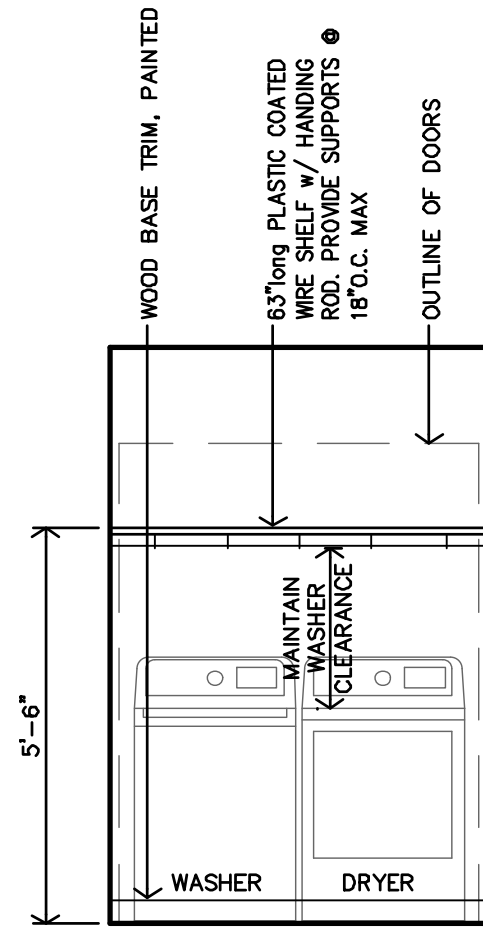

L UNIT 1D LAUNDRY #6
INTERIOR ELEV.
3/8"=1'-0" UNITS: 1E-SIMILAR MIRRORED

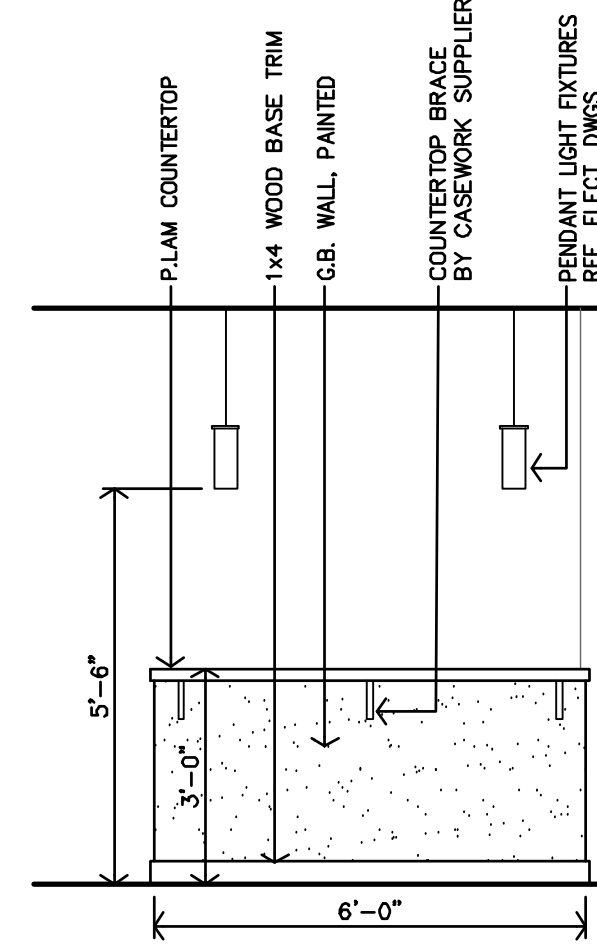

K UNIT 1D KITCHEN #3
INTERIOR ELEV.
3/8"=1'-0" UNITS: 1E-SIMILAR MIRRORED

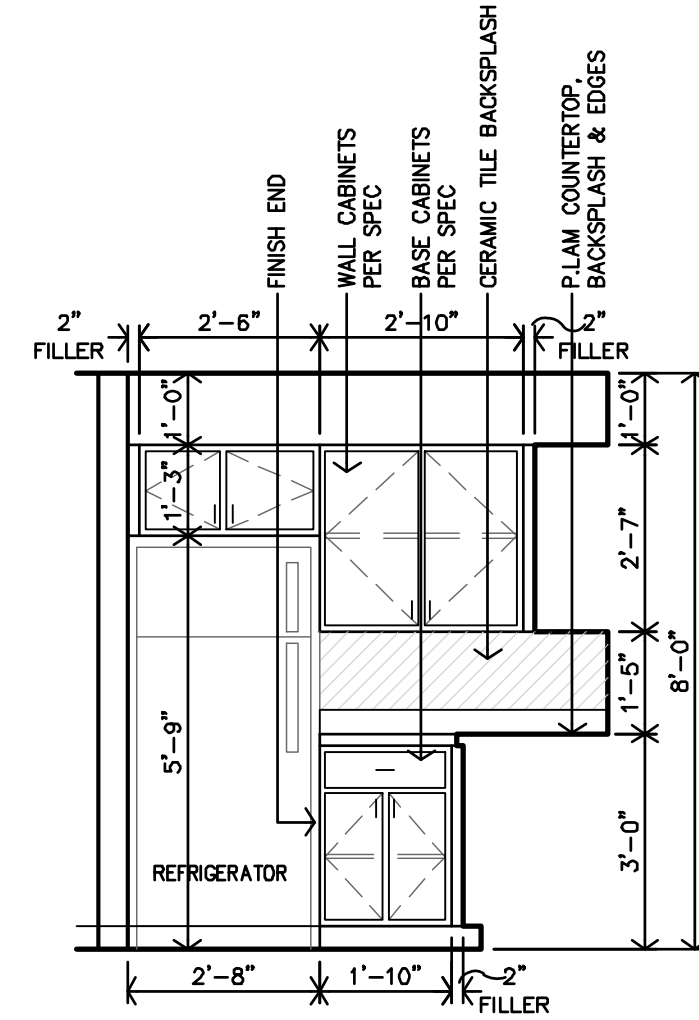

J UNIT 1D KITCHEN #3
INTERIOR ELEV.
3/8"=1'-0" UNITS: 1E-SIMILAR MIRRORED

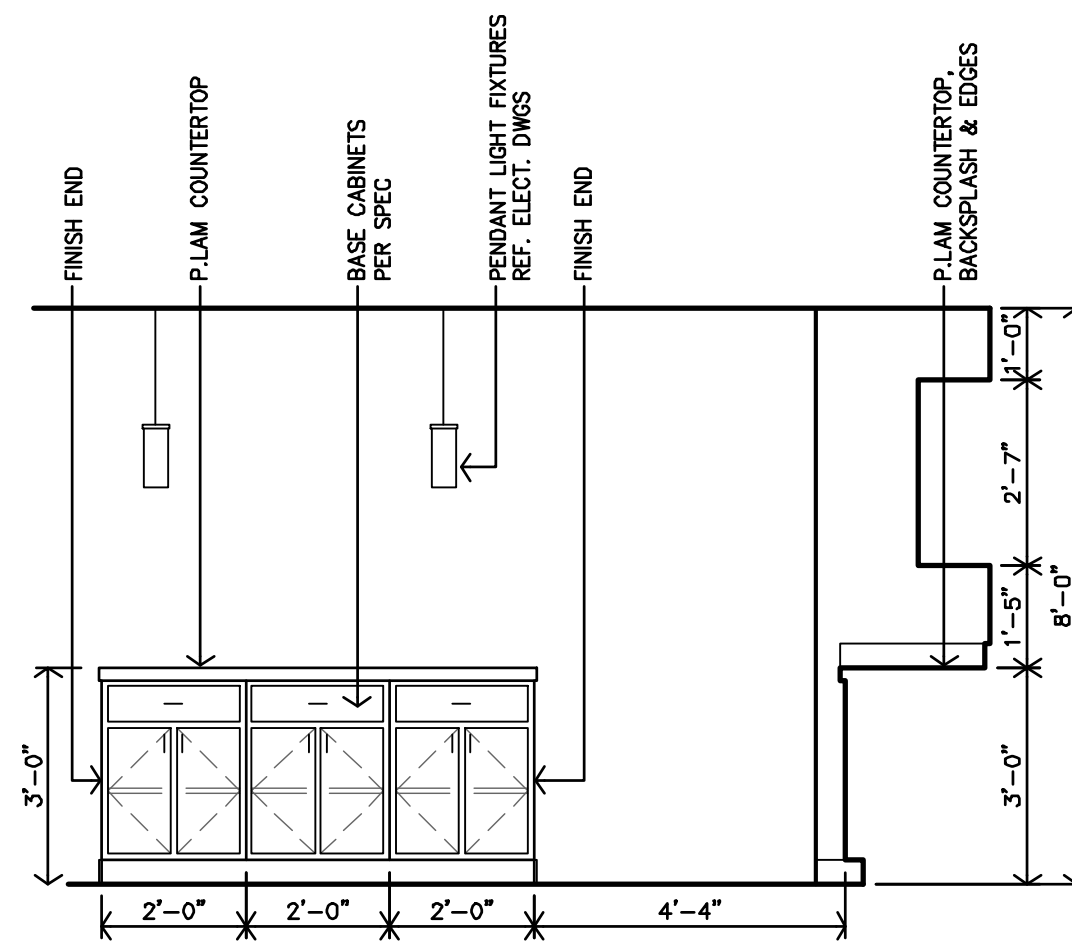

H UNIT 1D KITCHEN #3
INTERIOR ELEV.
3/8"=1'-0" UNITS: 1E-SIMILAR MIRRORED

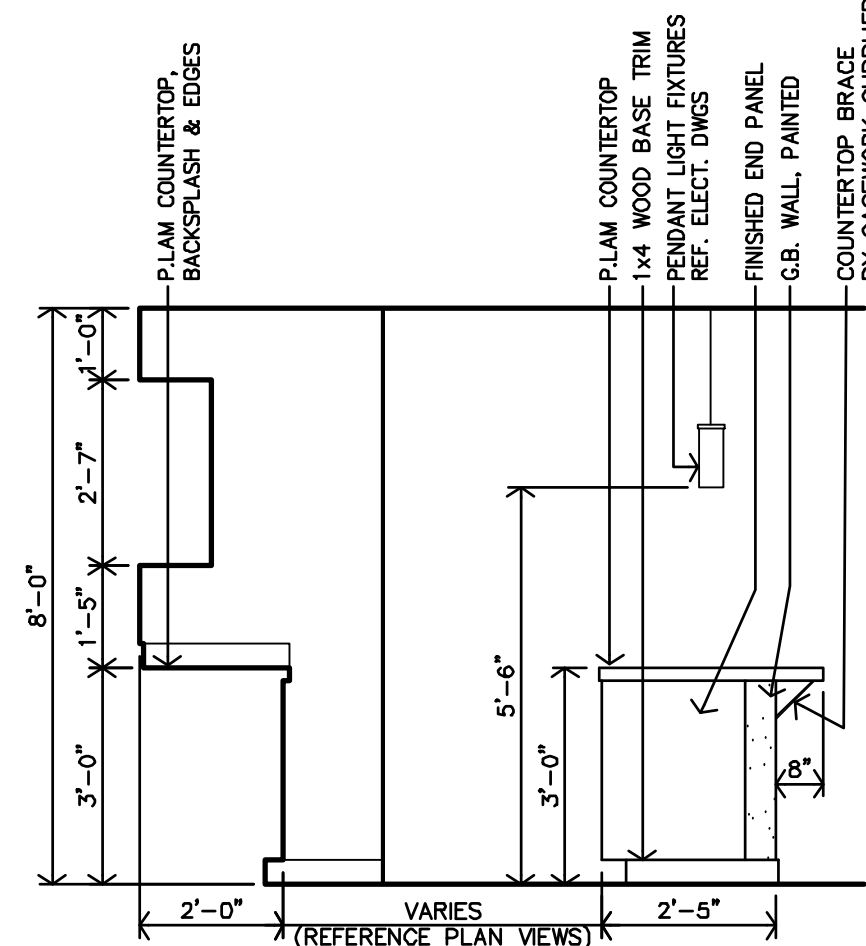

G UNIT 1D KITCHEN #3
INTERIOR ELEV.
3/8"=1'-0" UNITS: 1E-SIMILAR MIRRORED

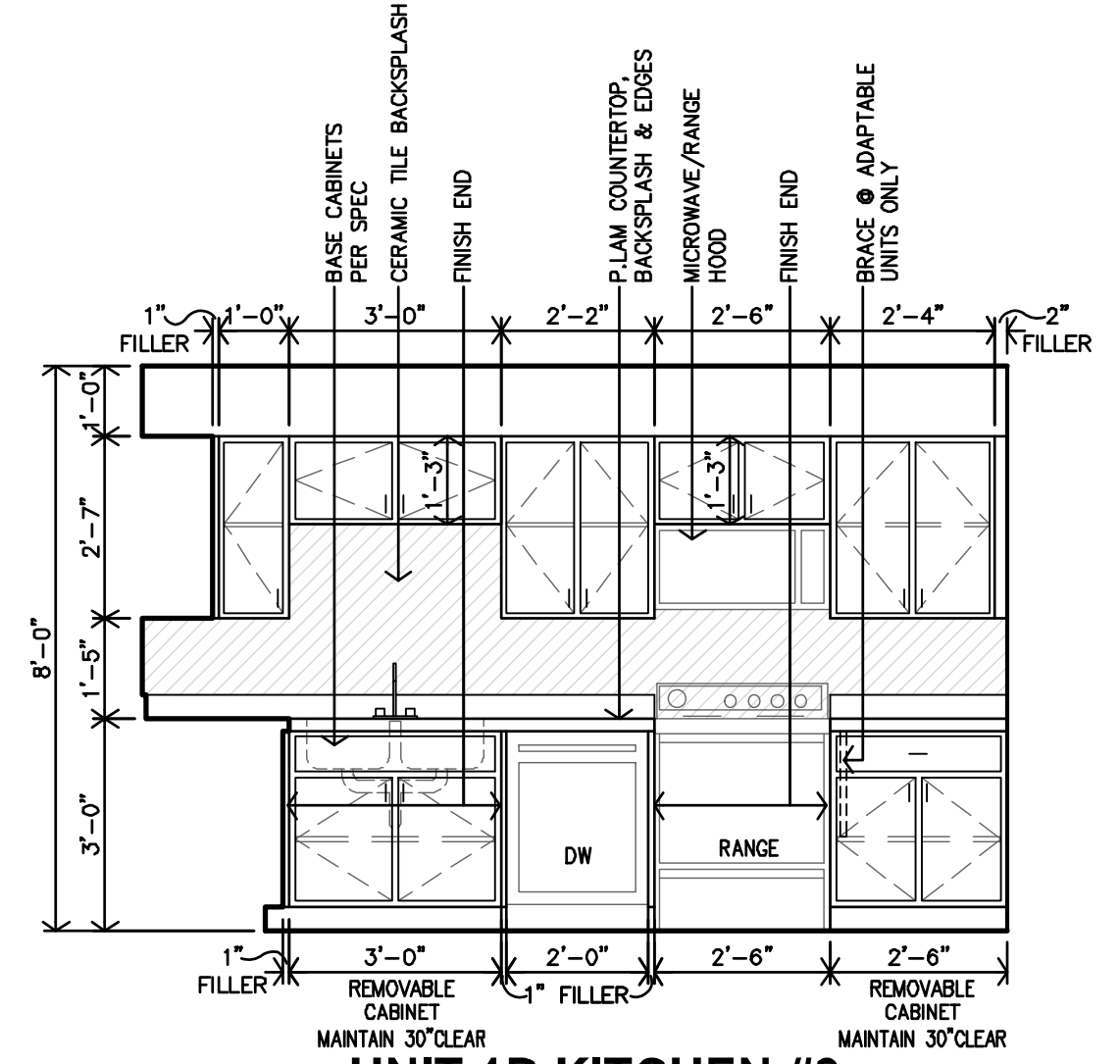

F UNIT 1D KITCHEN #3
INTERIOR ELEV.
3/8"=1'-0" UNITS: 1E-SIMILAR MIRRORED

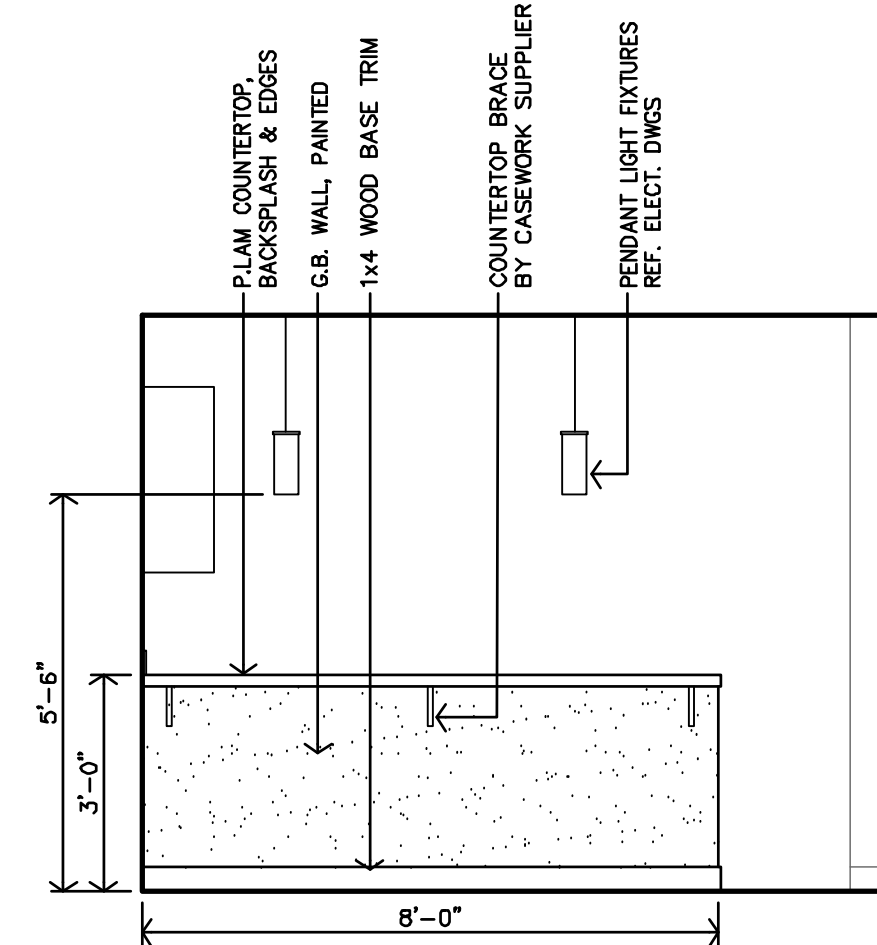

E UNITS 1B & 1C KITCHEN #3
INTERIOR ELEV.
3/8"=1'-0"

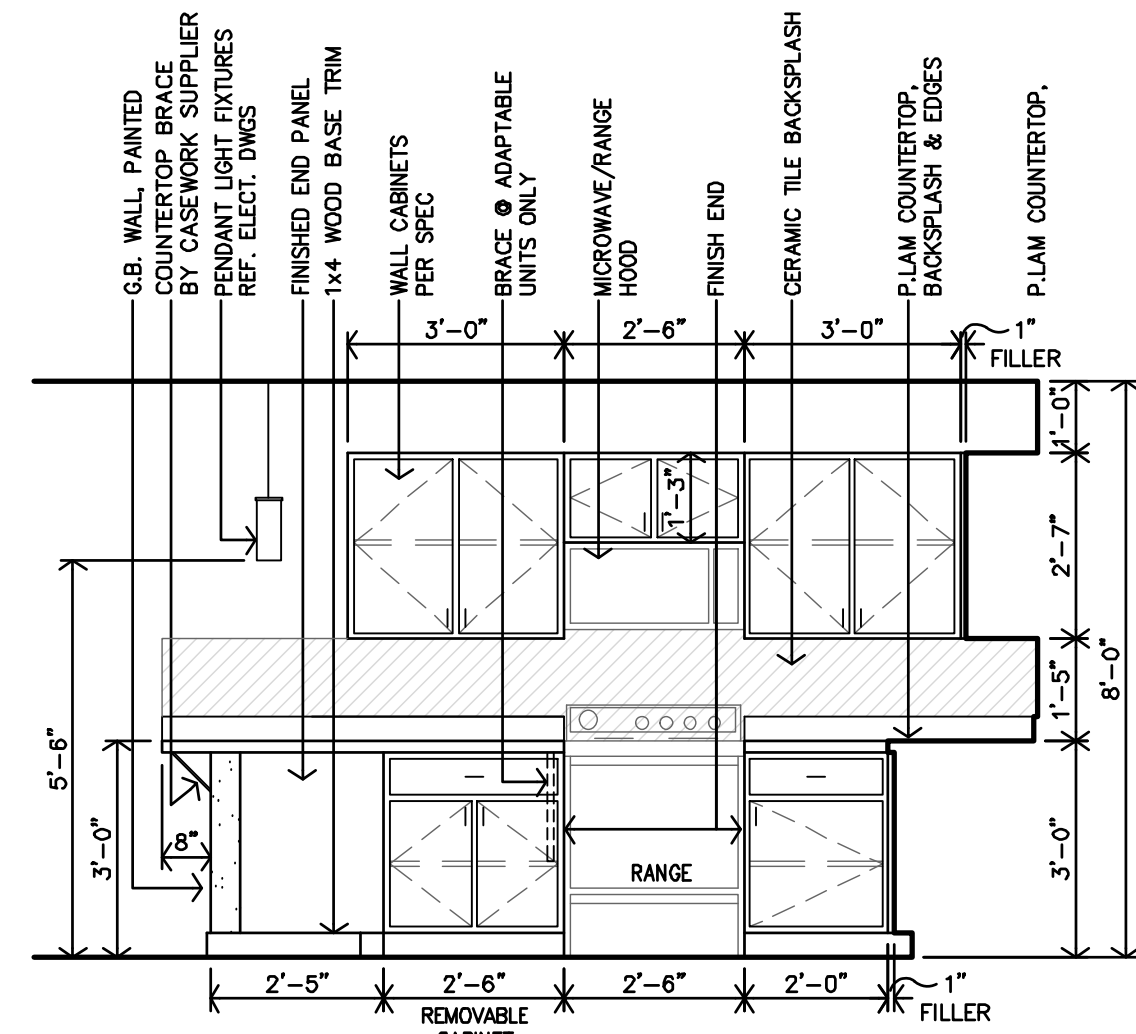

D UNITS 1B & 1C KITCHEN #3
INTERIOR ELEV.
3/8"=1'-0"

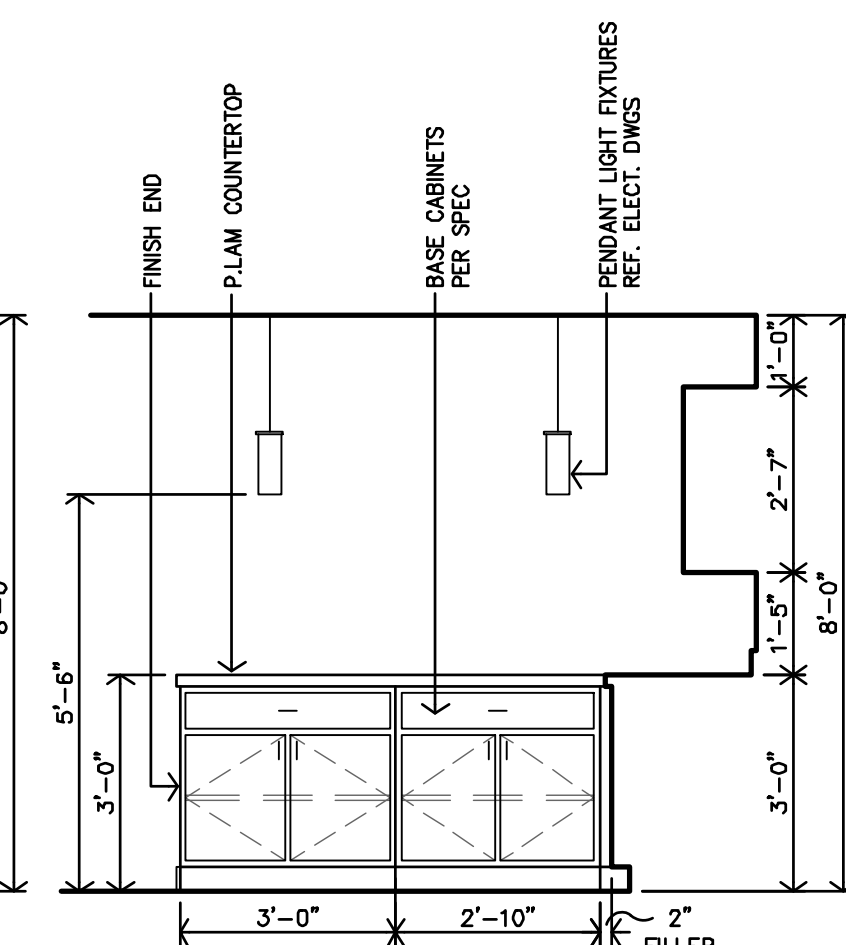

C UNITS 1B & 1C KITCHEN #3
INTERIOR ELEV.
3/8"=1'-0"

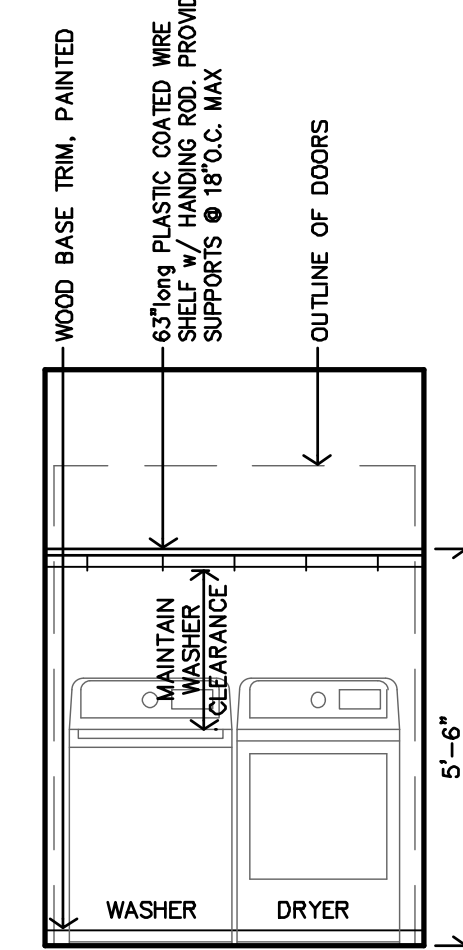

B UNITS 1B & 1C LAUNDRY #6
INTERIOR ELEV.
3/8"=1'-0"

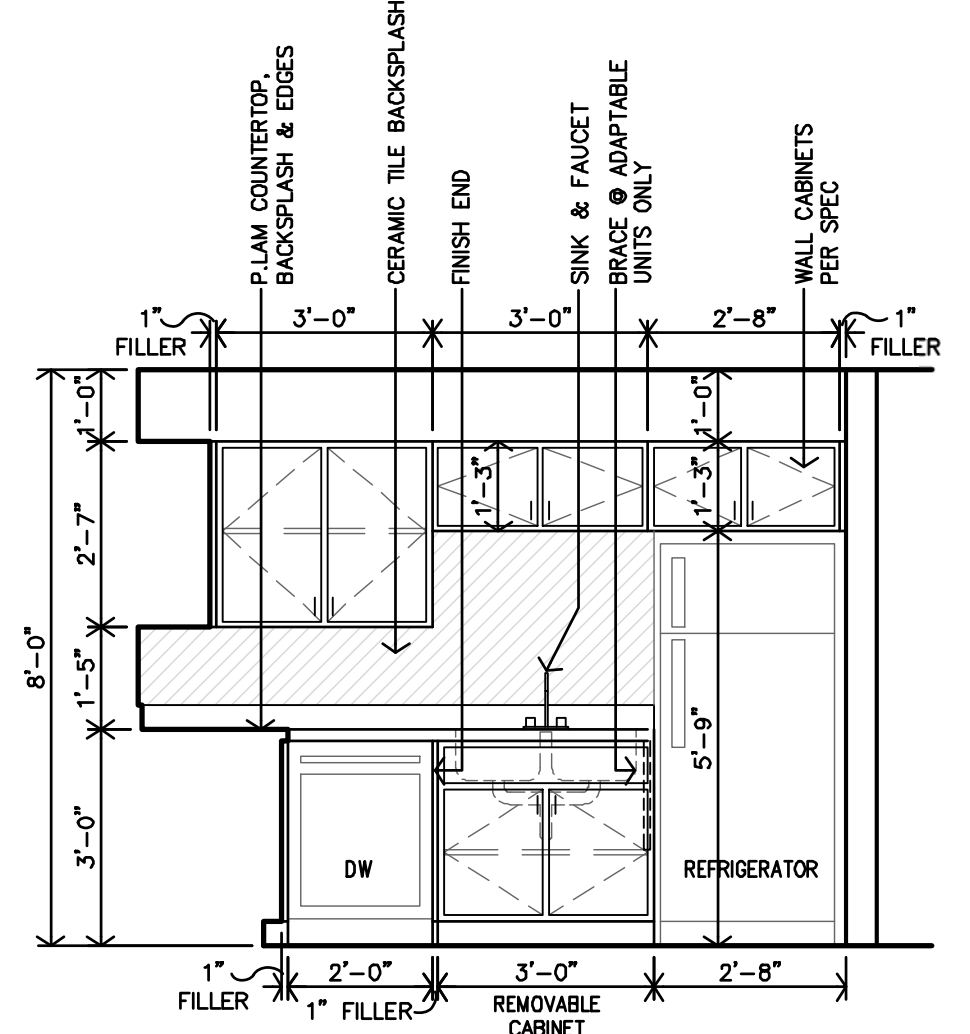

A UNITS 1B & 1C KITCHEN #3
INTERIOR ELEV.
3/8"=1'-0"



REVISION:	
DATE:	1-28-2022
JOB:	21-3137
SHEET:	

A2.10

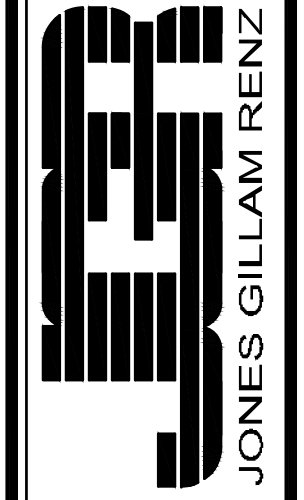

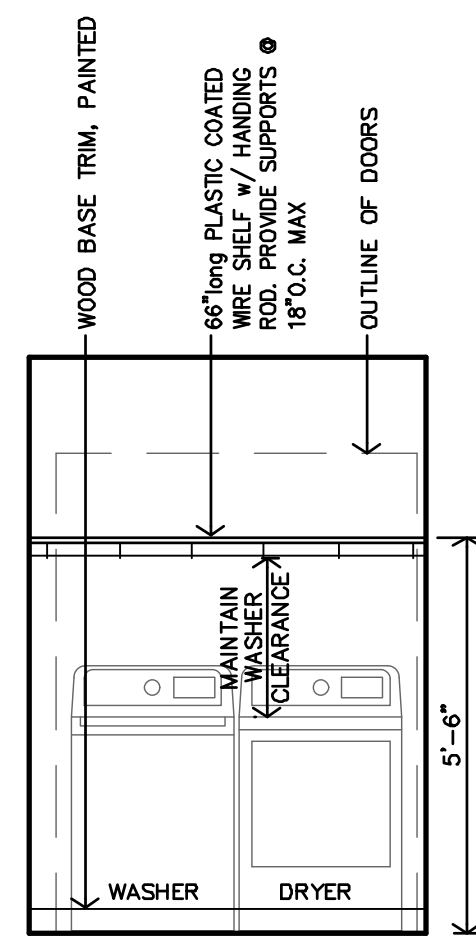

N UNIT 2D KITCHEN #3
INTERIOR ELEV.
3/8"=1'-0"

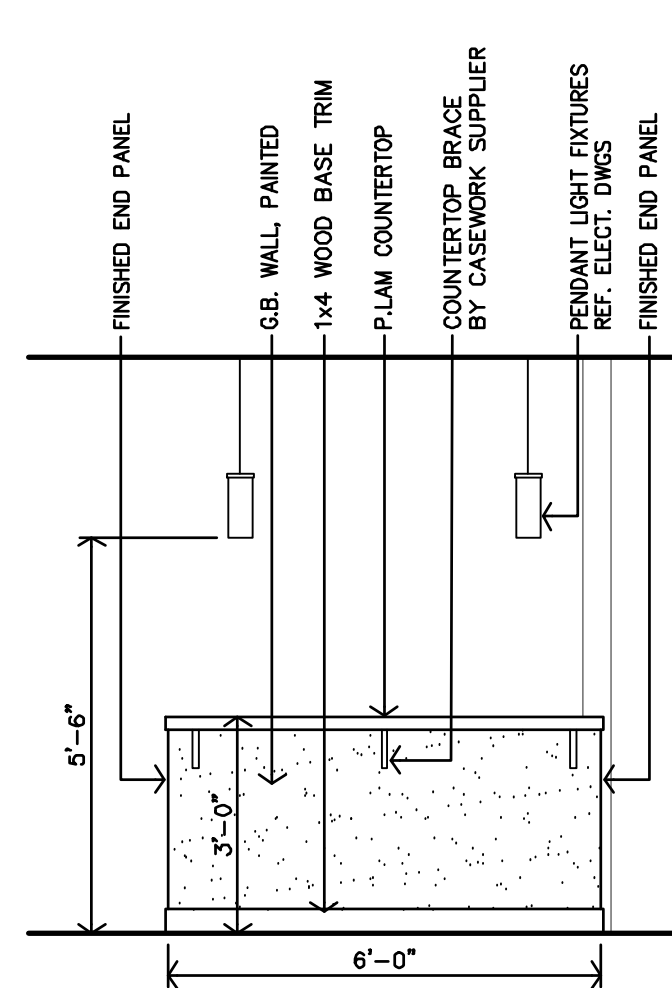

M UNIT 2D KITCHEN #3
INTERIOR ELEV.
3/8"=1'-0"

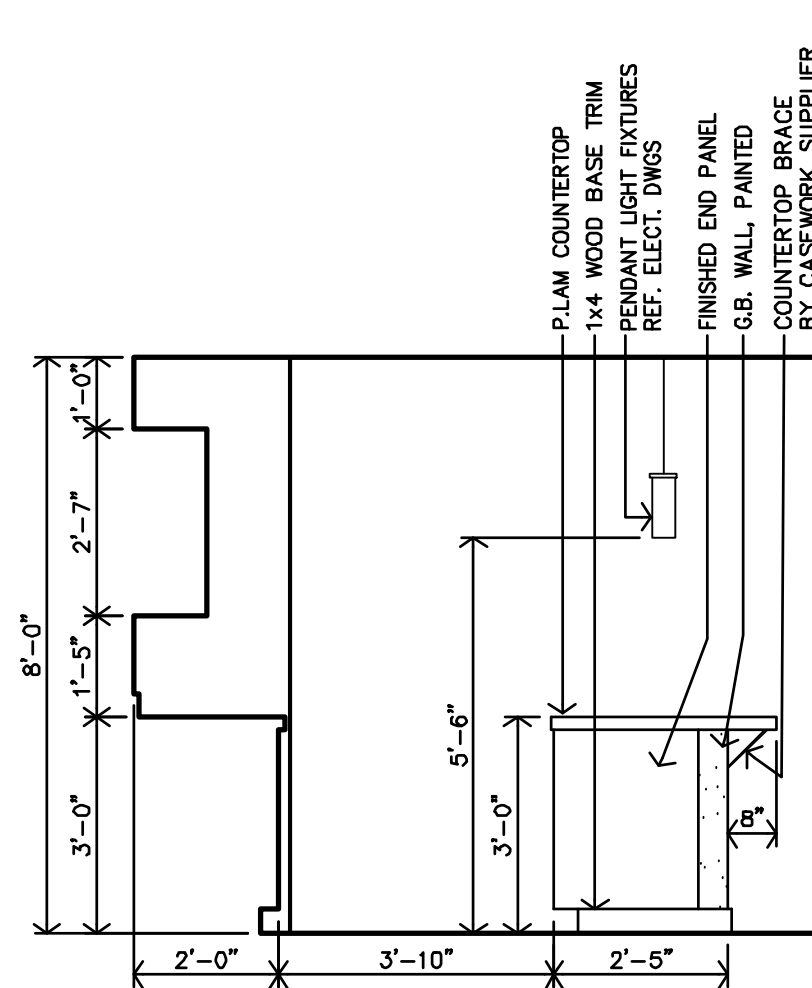

L UNIT 2D KITCHEN #3
INTERIOR ELEV.
3/8"=1'-0"

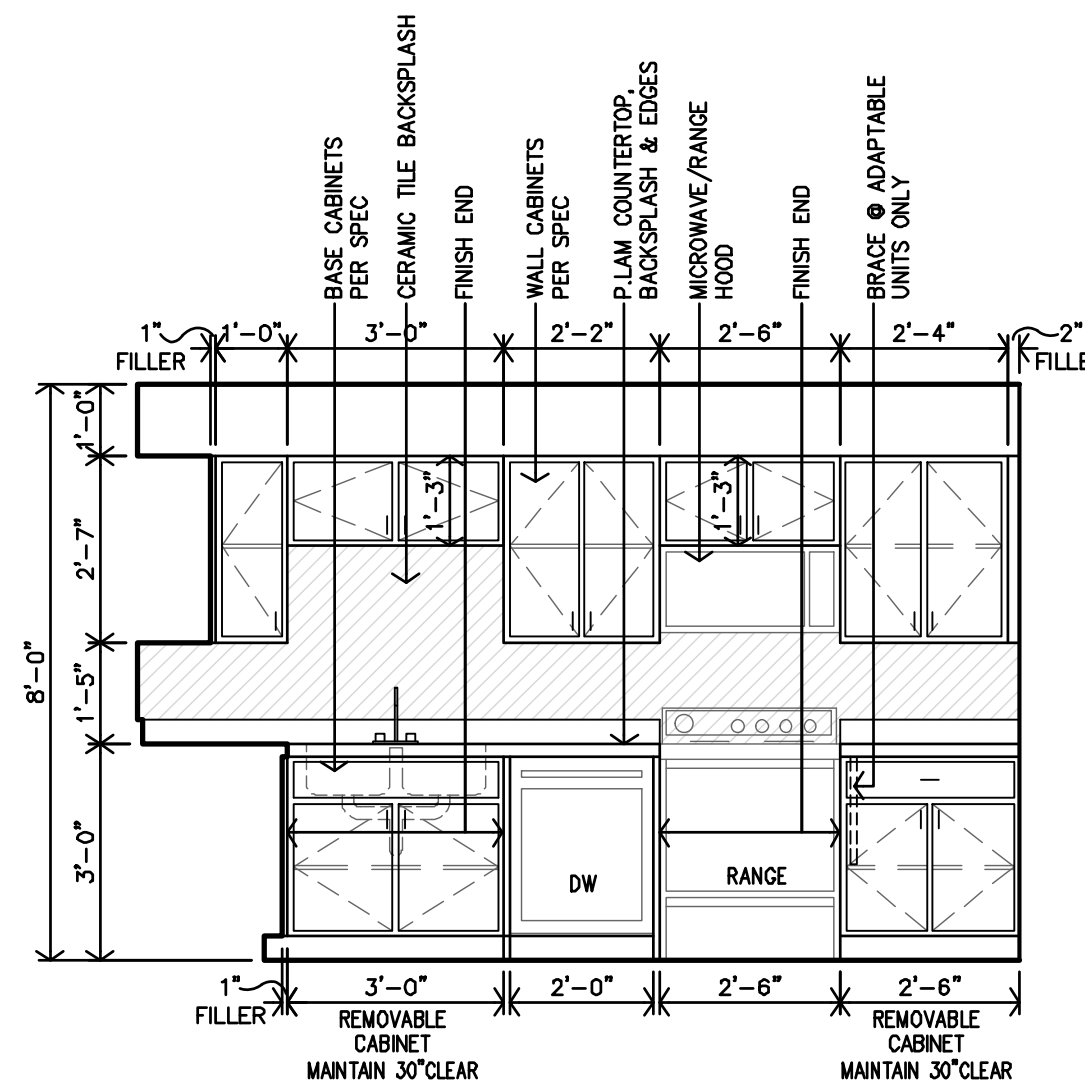

K UNIT 2D KITCHEN #3
INTERIOR ELEV.
3/8"=1'-0"

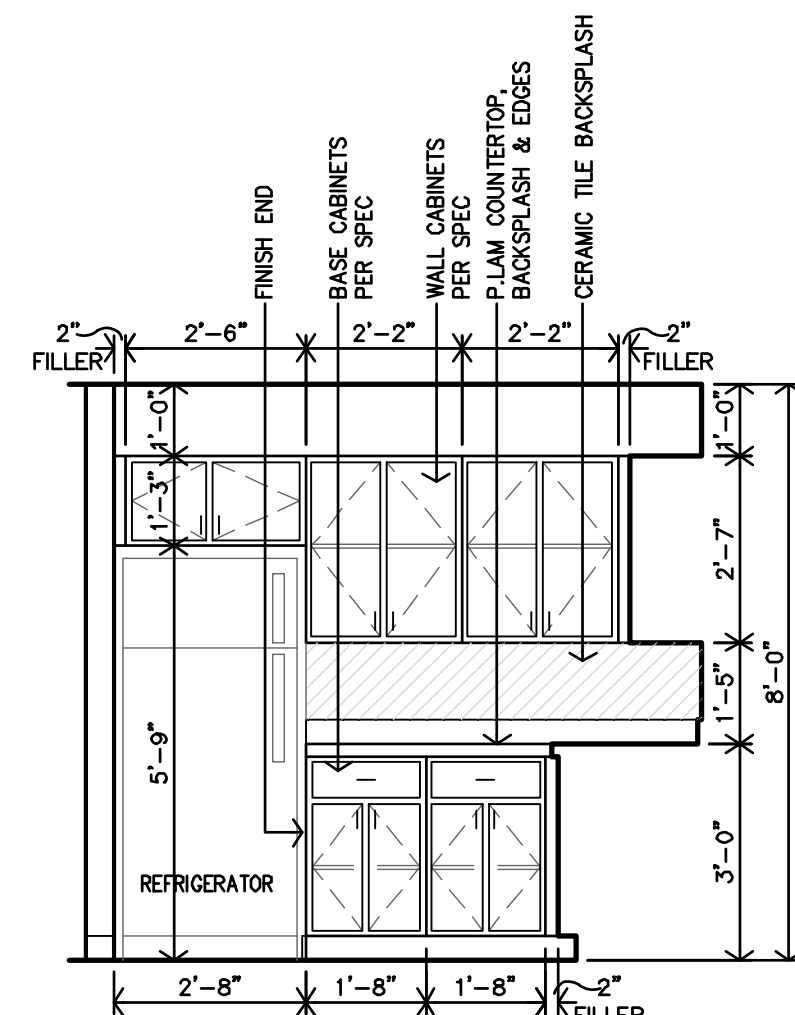

J UNIT 2D KITCHEN #3
INTERIOR ELEV.
3/8"=1'-0"

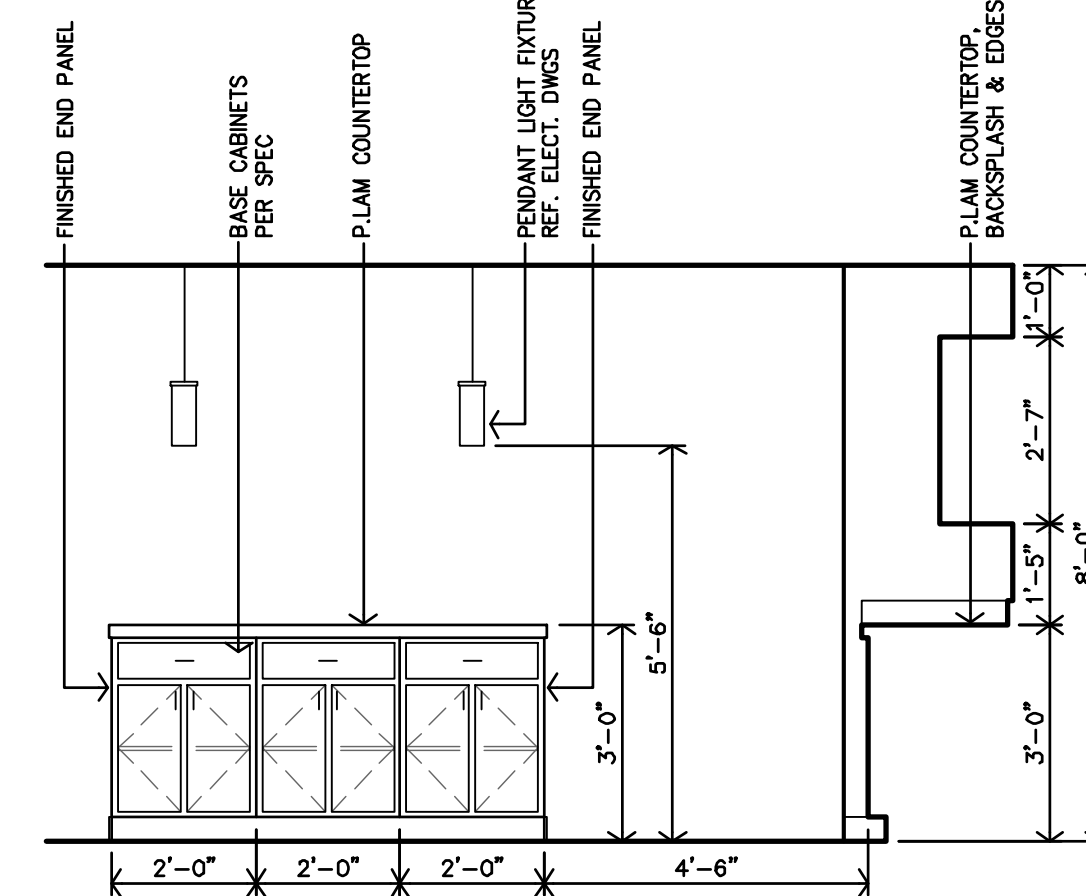

H UNIT 2D KITCHEN #3
INTERIOR ELEV.
3/8"=1'-0"

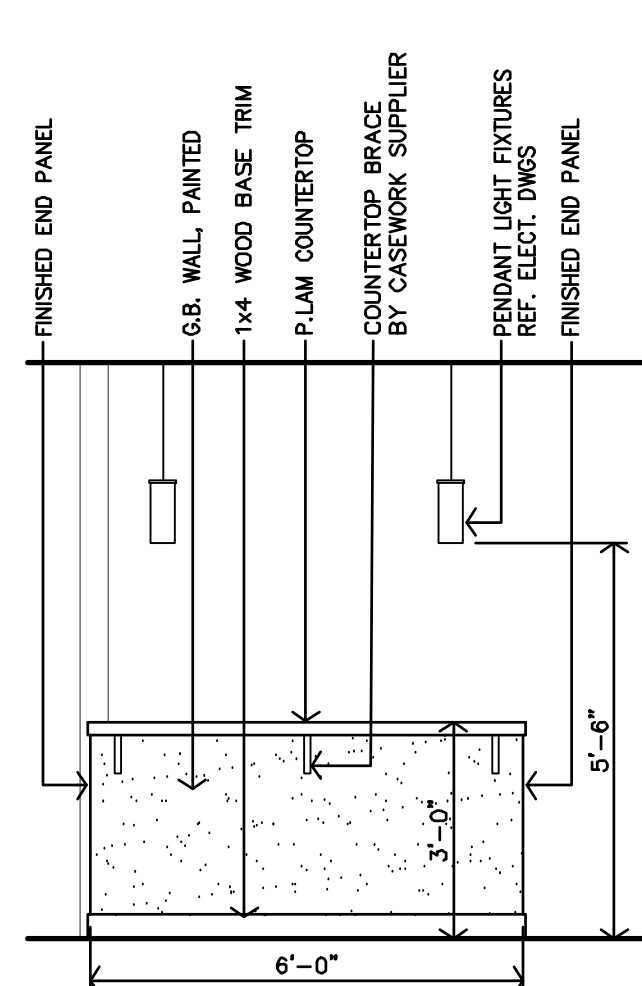

G UNITS 2B & 2C KITCHEN #3
INTERIOR ELEV.
3/8"=1'-0"

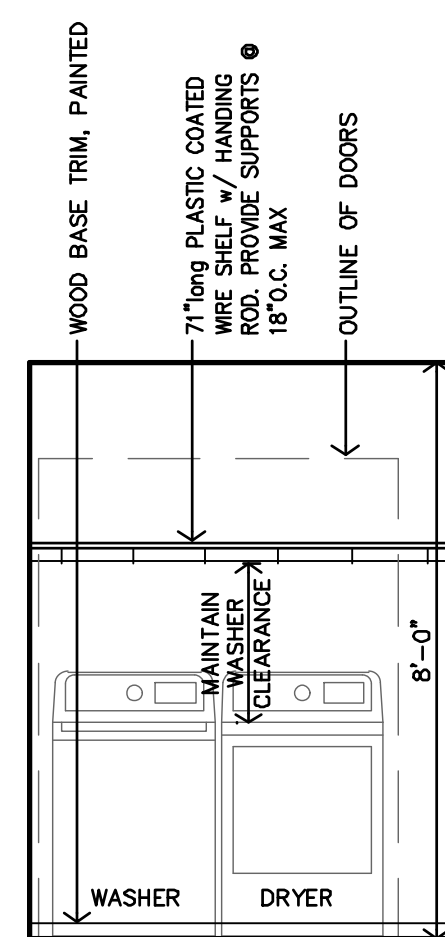

F UNITS 2B & 2C KITCHEN #3
INTERIOR ELEV.
3/8"=1'-0"

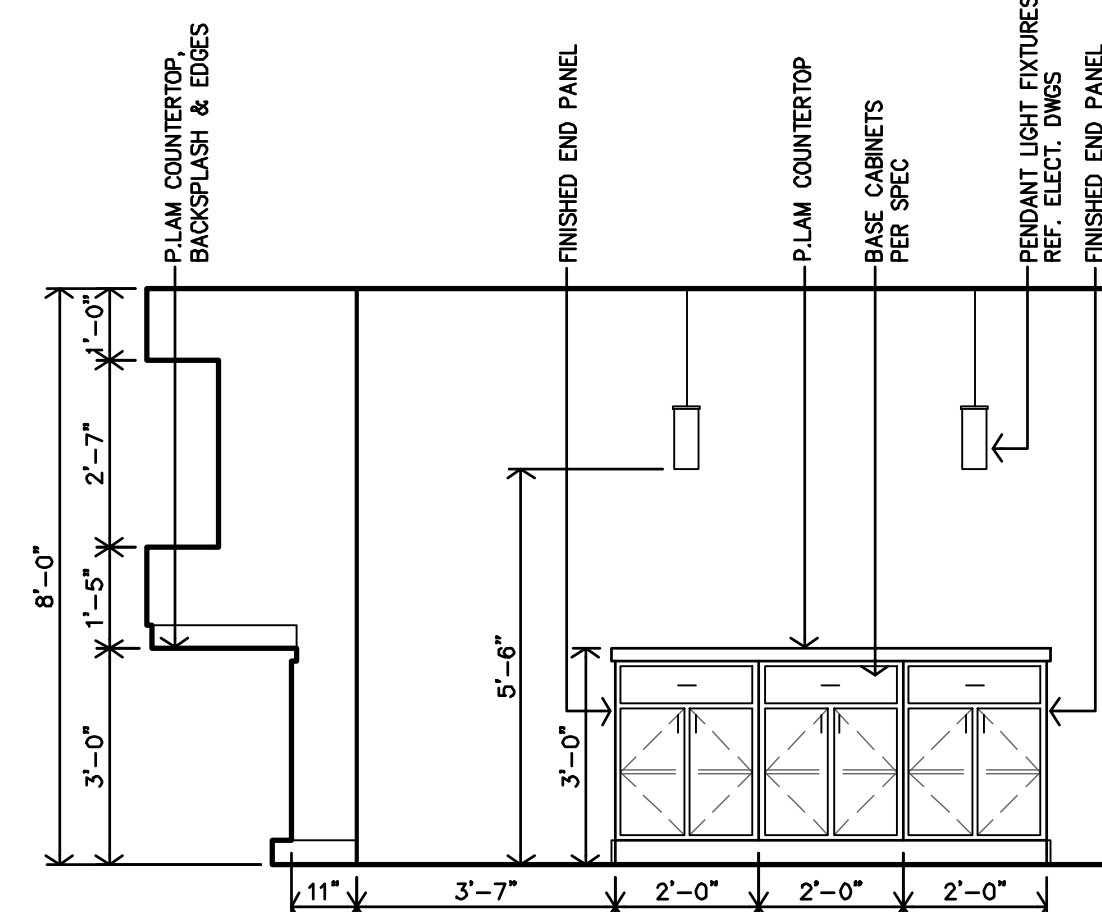

E UNITS 2B & 2C KITCHEN #3
INTERIOR ELEV.
3/8"=1'-0"

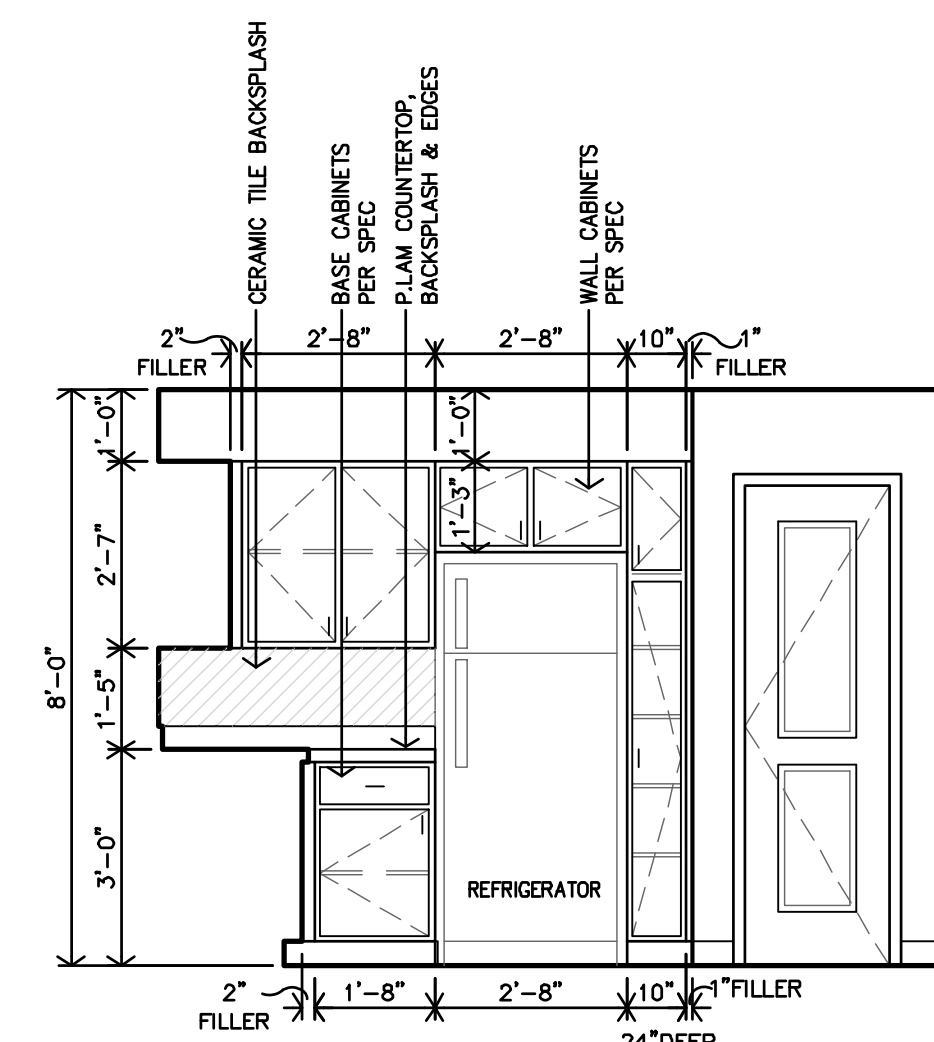

D UNITS 2B & 2C KITCHEN #3
INTERIOR ELEV.
3/8"=1'-0"

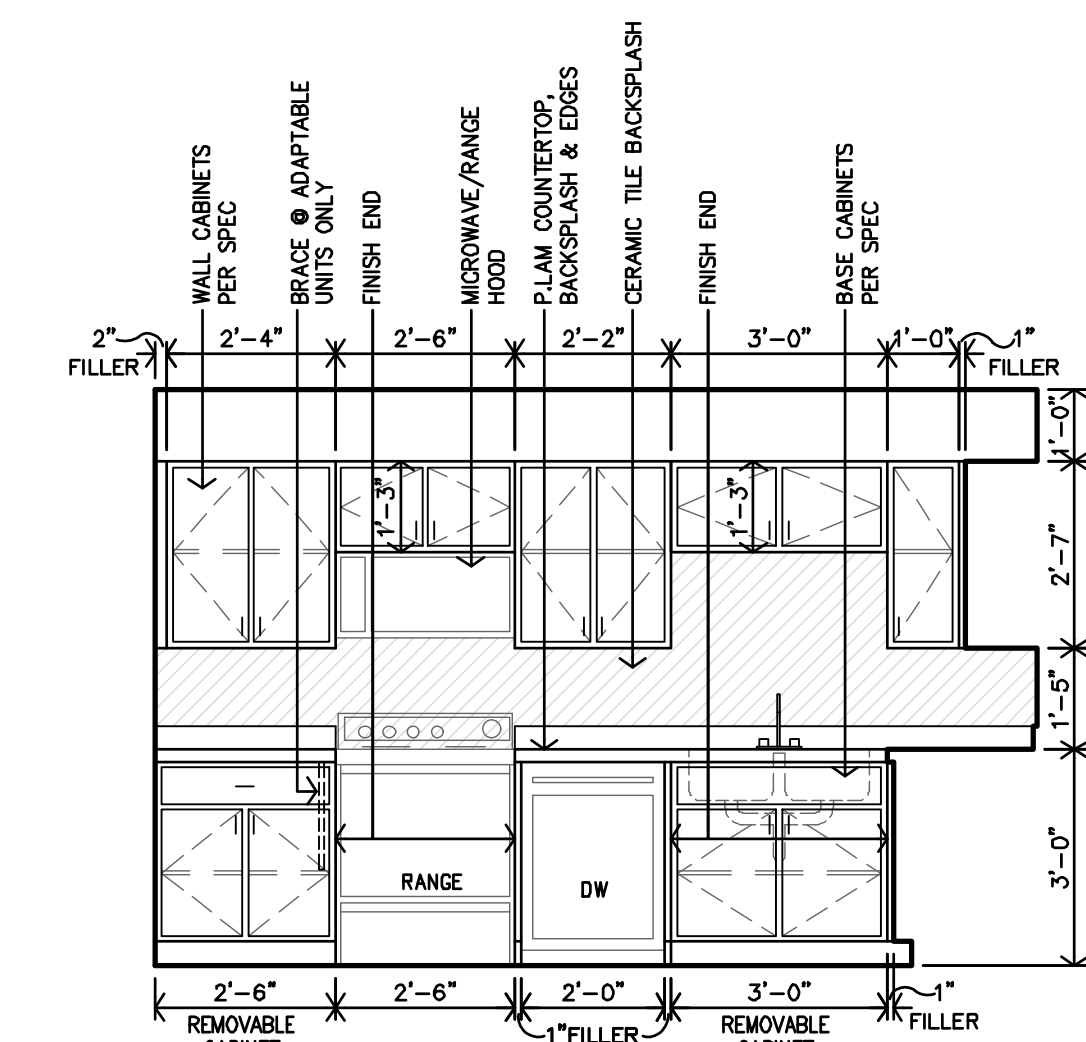

C UNITS 2B & 2C KITCHEN #3
INTERIOR ELEV.
3/8"=1'-0"

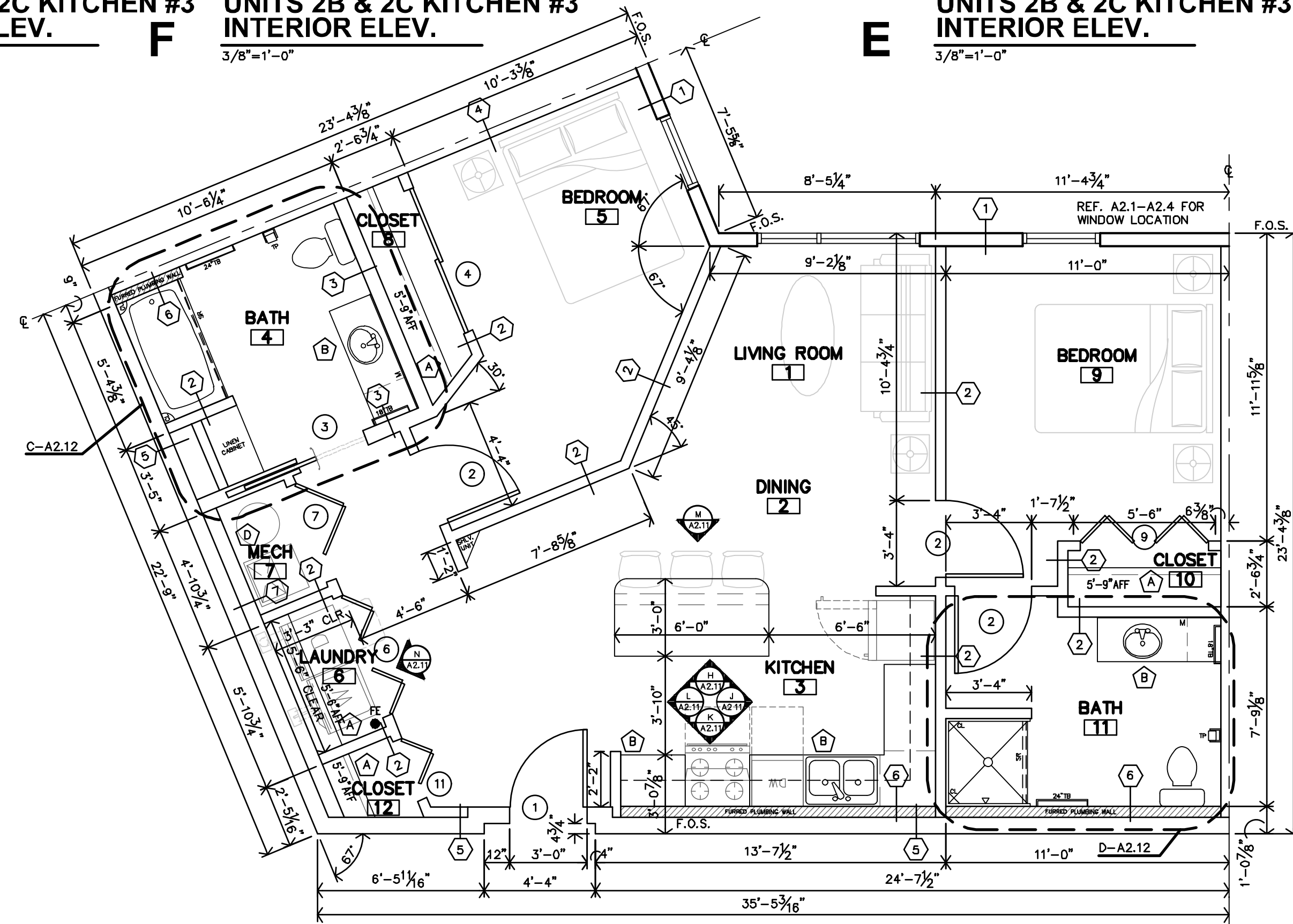

B UNIT 2D ADAPTABLE
2 BEDROOM - 2BATH UNIT PLAN
1/4"=1'-0"

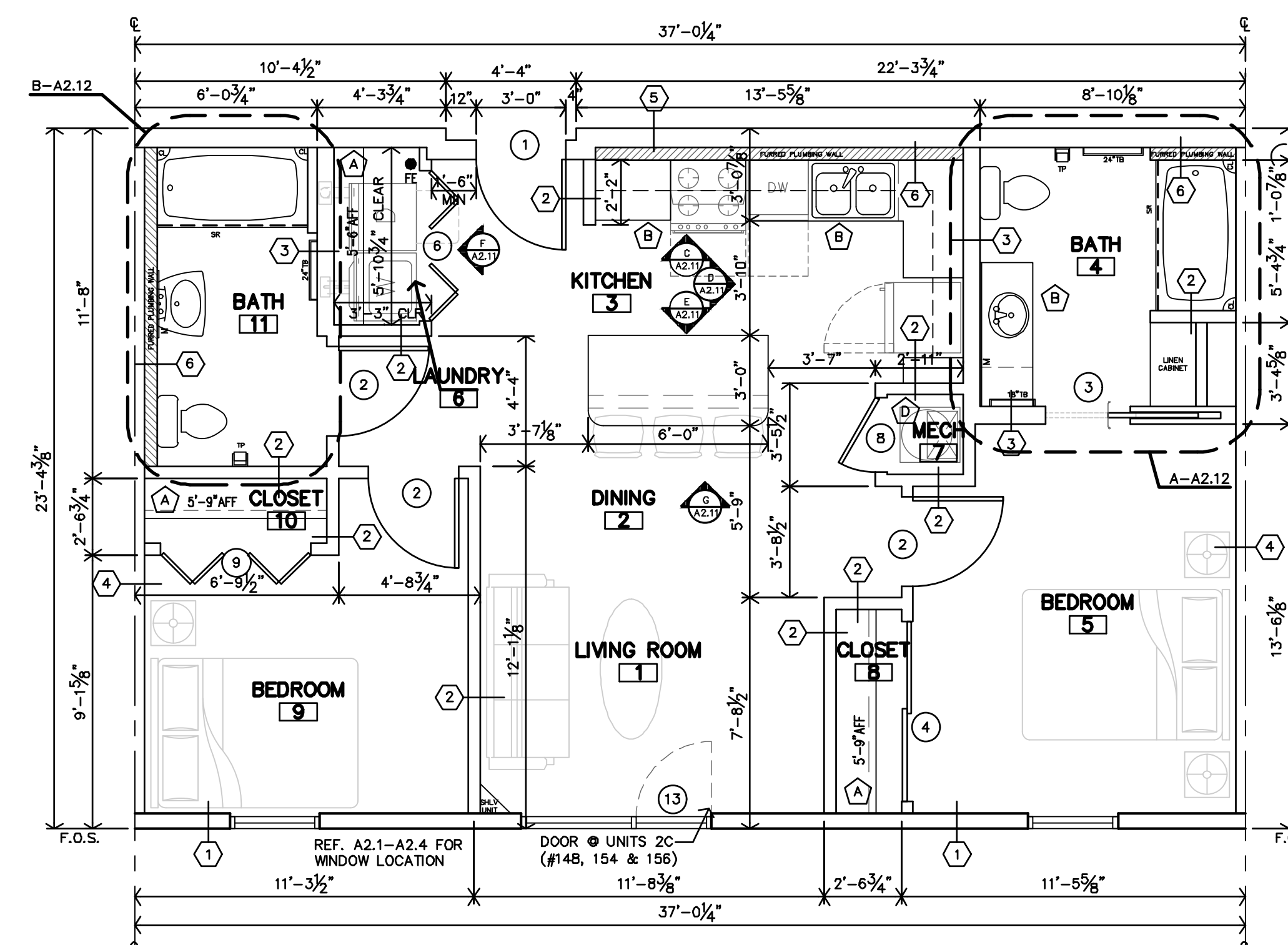

A UNITS 2B & 2C ADAPTABLE
2 BEDROOM - 2 BATH UNIT PLAN
1/4"=1'-0"



REVISION:	
DATE:	1-28-2022
JOB:	21-3137
SHEET:	

A2.11

CLIFTON RIVERSIDE APARTMENTS
NEW APARTMENTS
FORT WORTH, TEXAS

Architects Planners Designers
730 N. Fifth
P.O. Box 2928
Salina, KS 67402
1880 Main Street, Suite 301
Kansas City, MO 64108
jgr@jgarchitects.com
785.827.0386

COPYRIGHTED ©

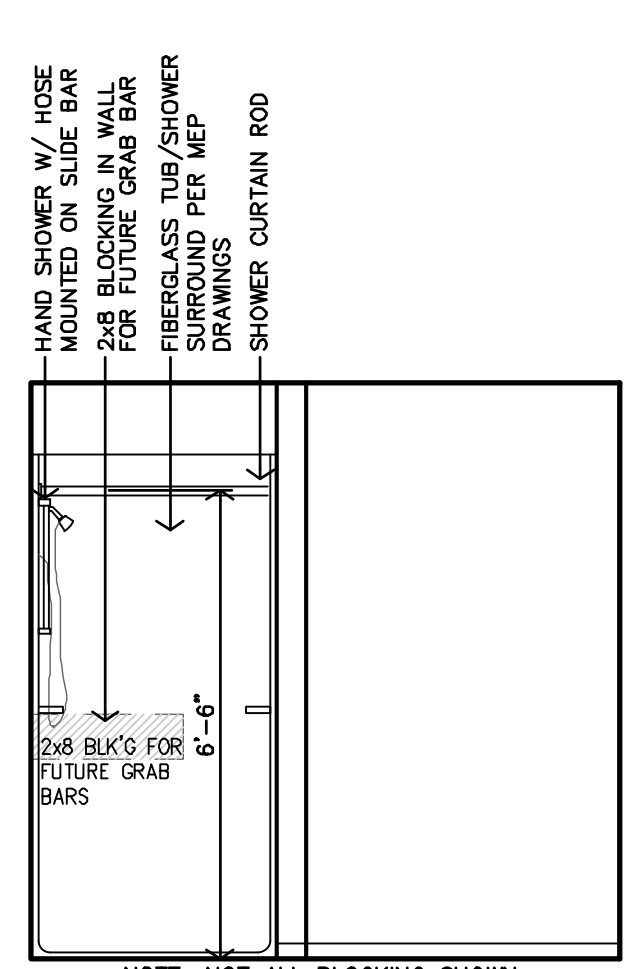

NOTE: NOT ALL BLOCKING SHOWN.

U UNIT 2D - BATH #11
INTERIOR ELEV.
3/8"=1'-0"

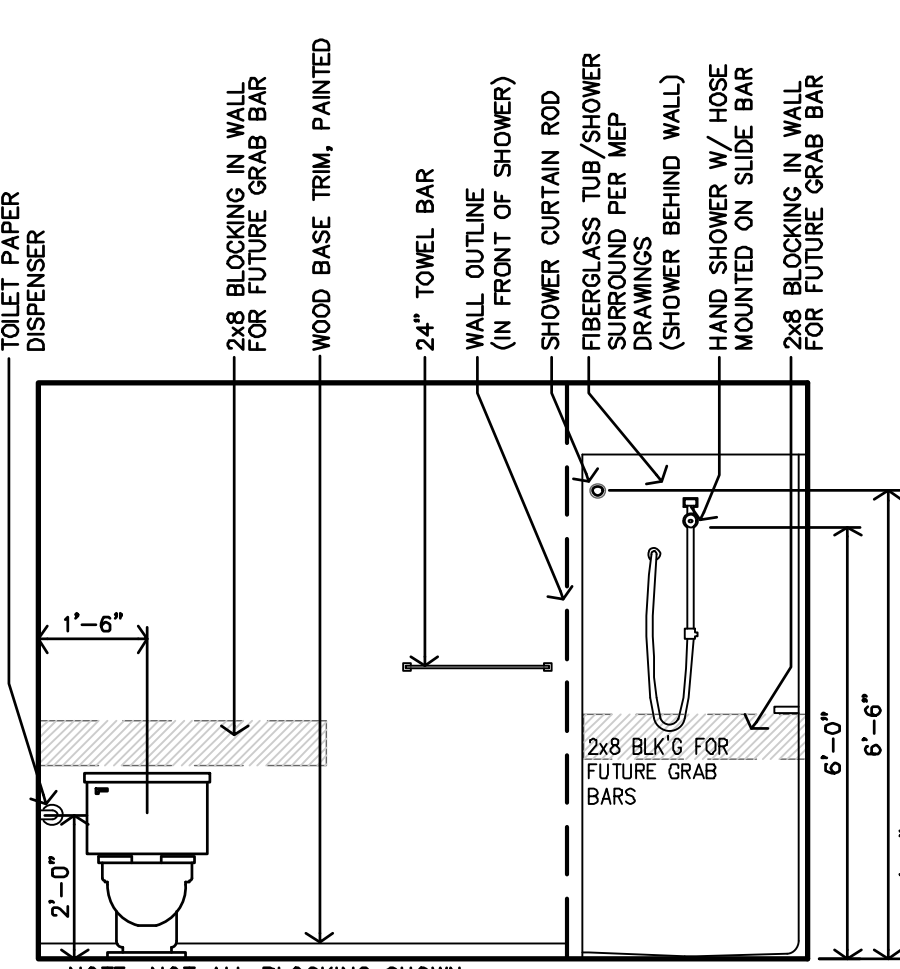

NOTE: NOT ALL BLOCKING SHOWN.

T UNIT 2D - BATH #11
INTERIOR ELEV.
3/8"=1'-0"

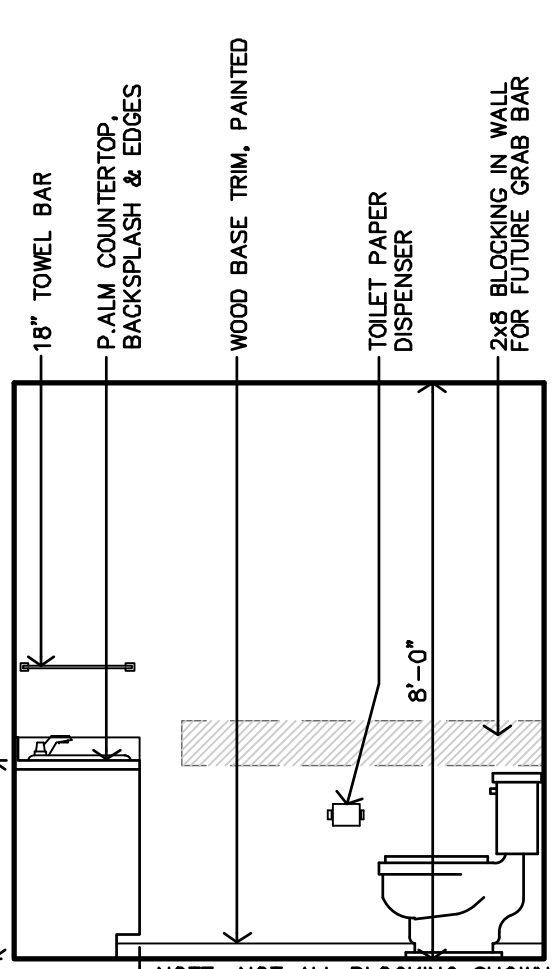

NOTE: NOT ALL BLOCKING SHOWN.

S UNIT 2D - BATH #11
INTERIOR ELEV.
3/8"=1'-0"

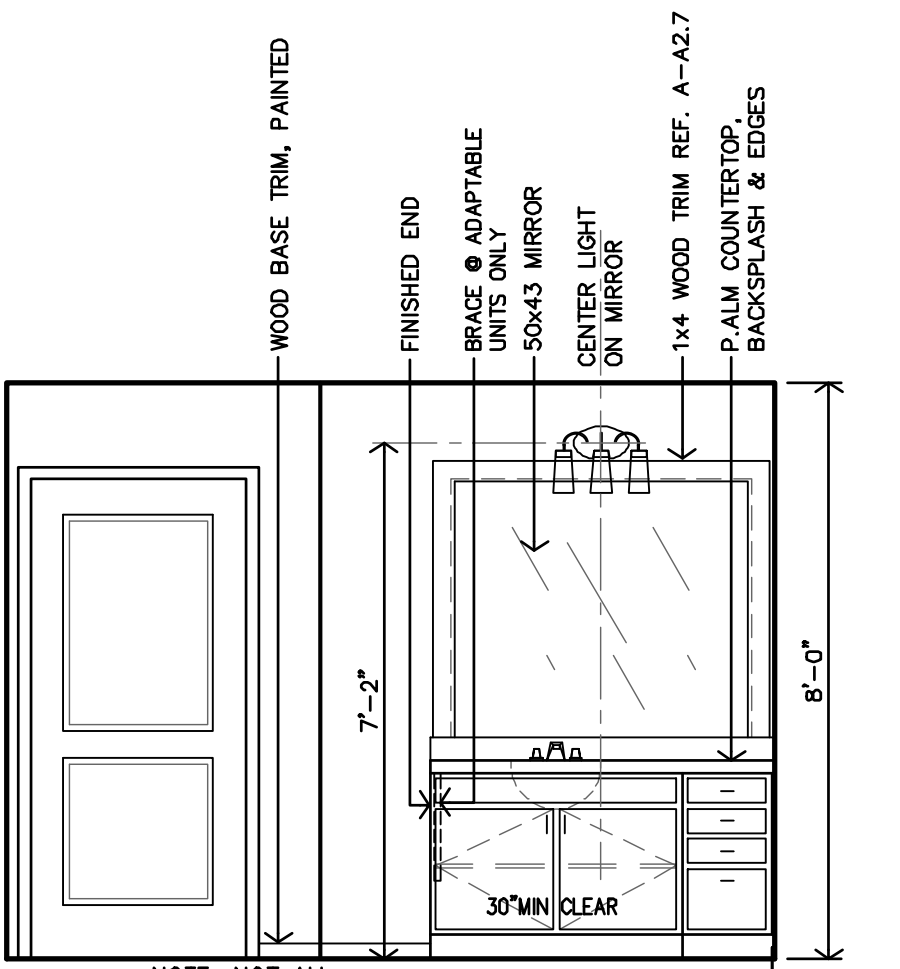

NOTE: NOT ALL BLOCKING SHOWN.

R UNIT 2D - BATH #11
INTERIOR ELEV.
3/8"=1'-0"

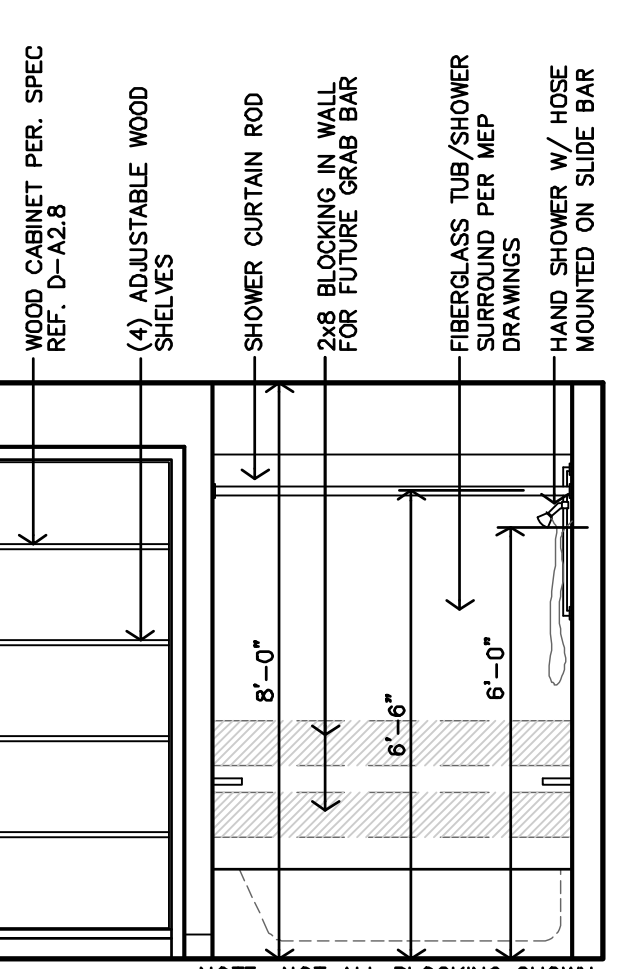

NOTE: NOT ALL BLOCKING SHOWN.

Q UNIT 2D - BATH #4
INTERIOR ELEV.
3/8"=1'-0"

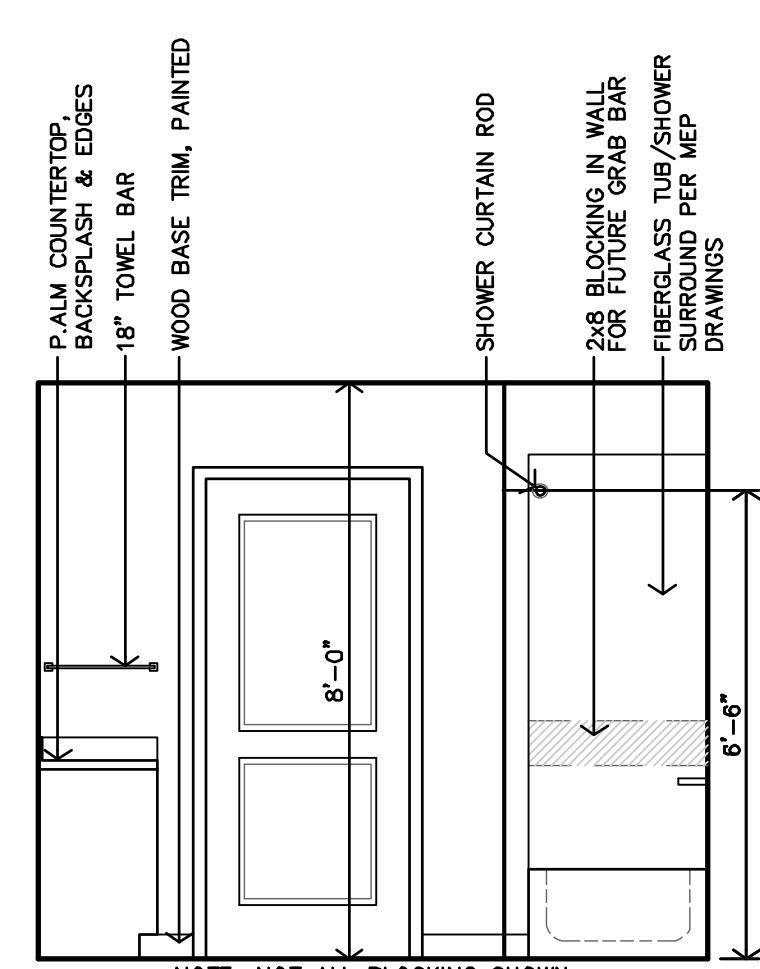

NOTE: NOT ALL BLOCKING SHOWN.

P UNIT 2D - BATH #4
INTERIOR ELEV.
3/8"=1'-0"

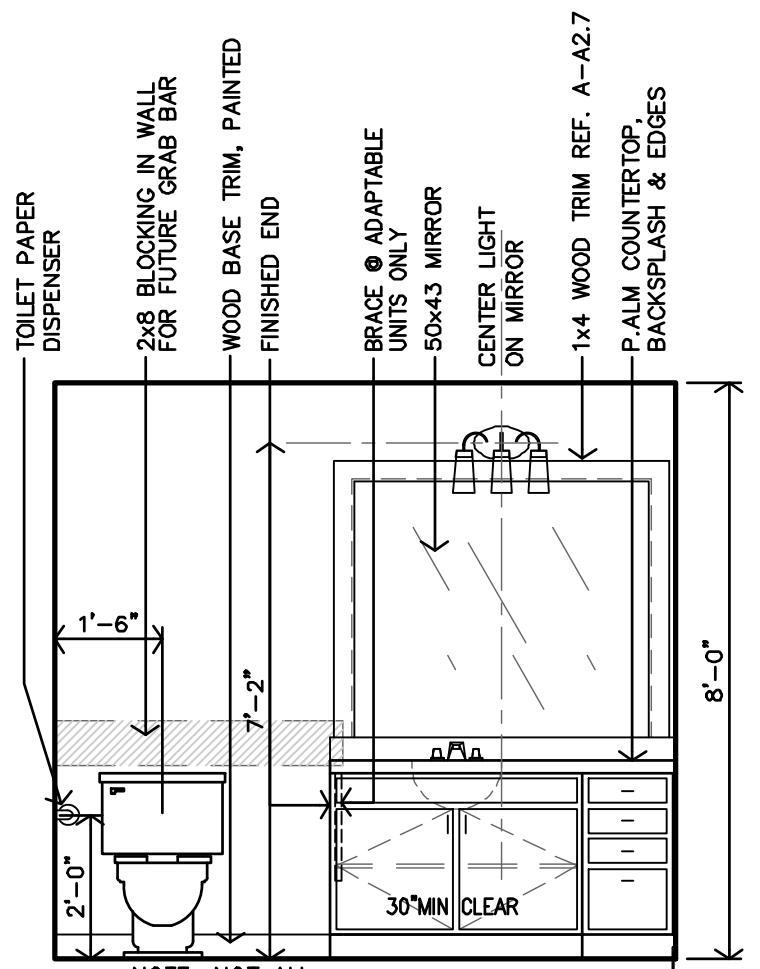

NOTE: NOT ALL BLOCKING SHOWN.

O UNIT 2D - BATH #4
INTERIOR ELEV.
3/8"=1'-0"

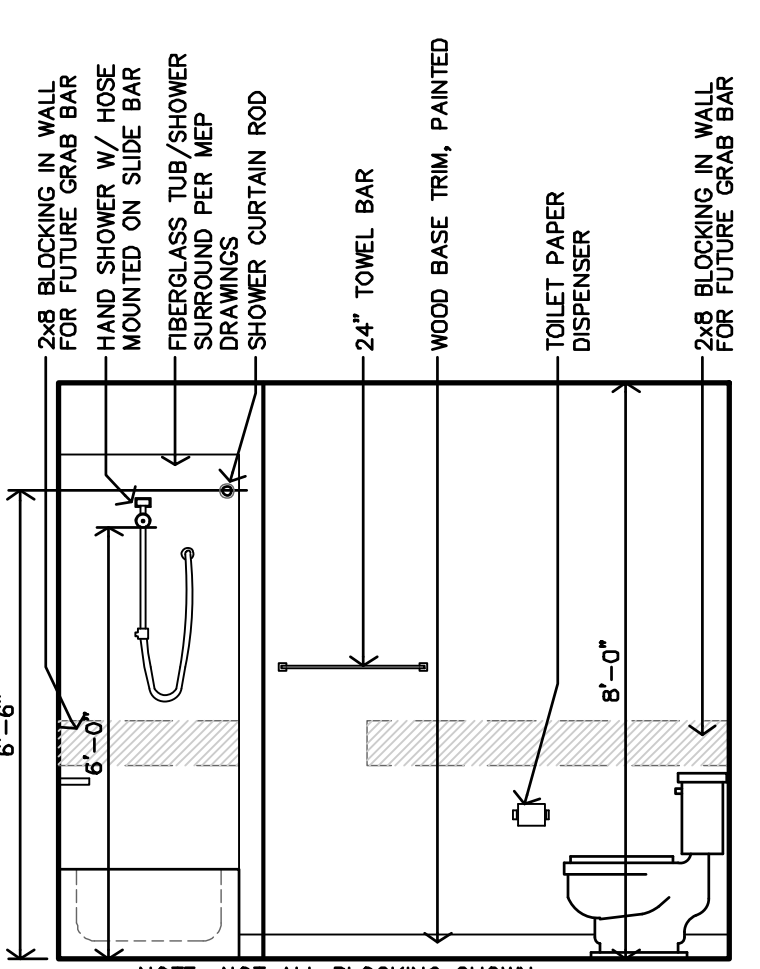

NOTE: NOT ALL BLOCKING SHOWN.

N UNIT 2D - BATH #4
INTERIOR ELEV.
3/8"=1'-0"

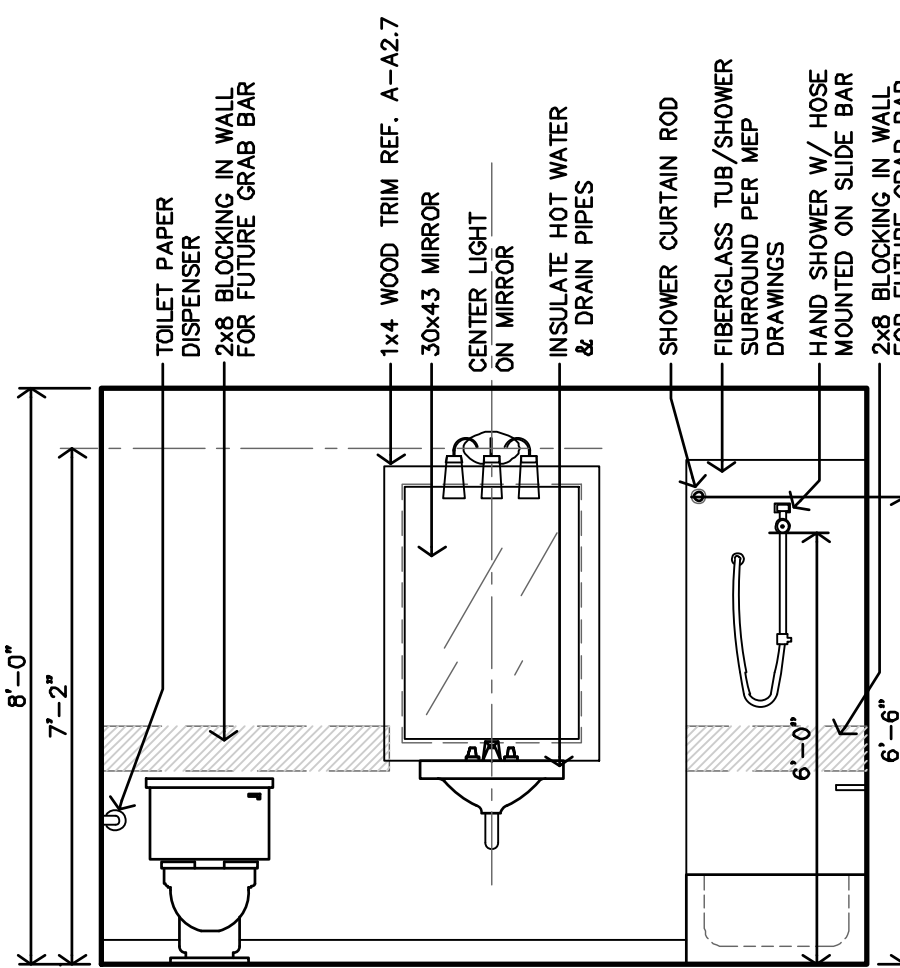

NOTE: NOT ALL BLOCKING SHOWN.

M UNITS 2B & 2C
BATH #11
INTERIOR ELEV.
3/8"=1'-0"

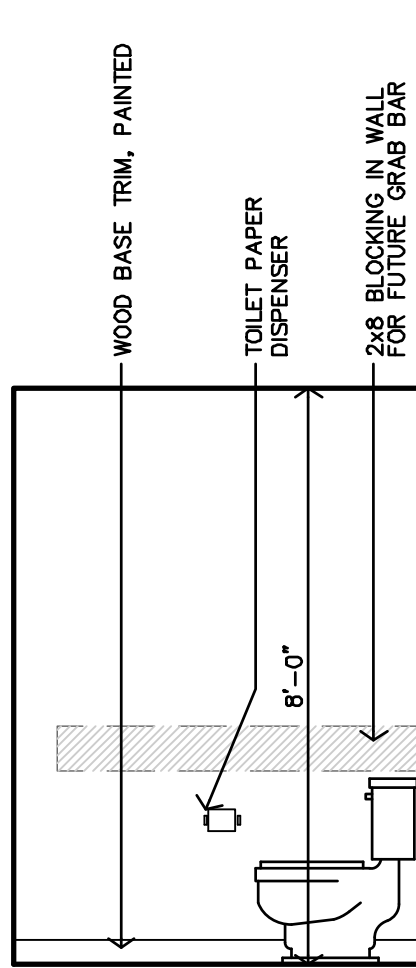

NOTE: NOT ALL BLOCKING SHOWN.

L UNITS 2B & 2C
BATH #11
INTERIOR ELEV.
3/8"=1'-0"

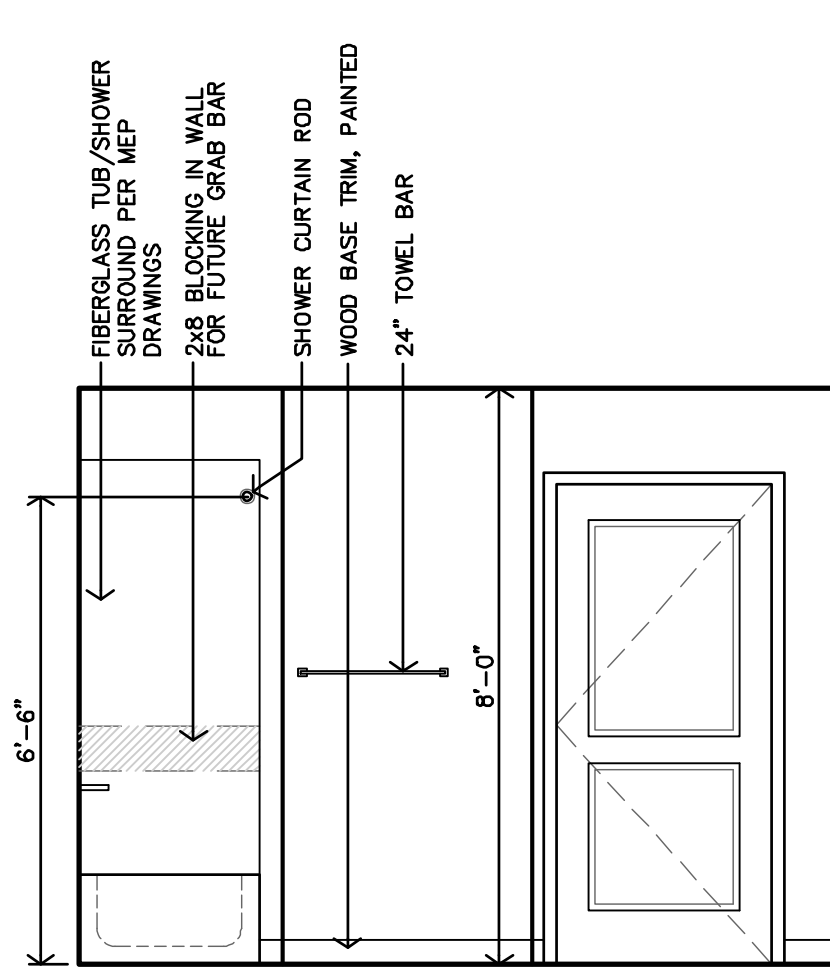

NOTE: NOT ALL BLOCKING SHOWN.

K UNITS 2B & 2C
BATH #11
INTERIOR ELEV.
3/8"=1'-0"

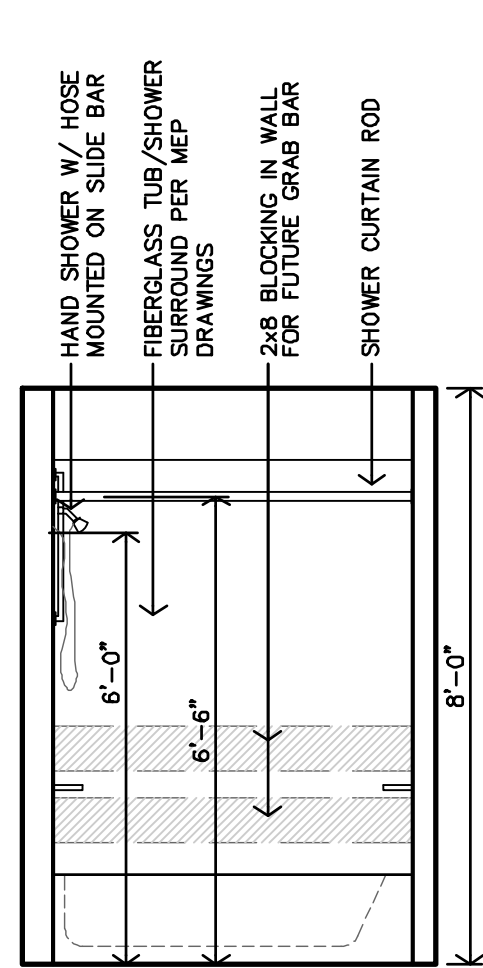

NOTE: NOT ALL BLOCKING SHOWN.

J UNITS 2B & 2C
BATH #11
INTERIOR ELEV.
3/8"=1'-0"

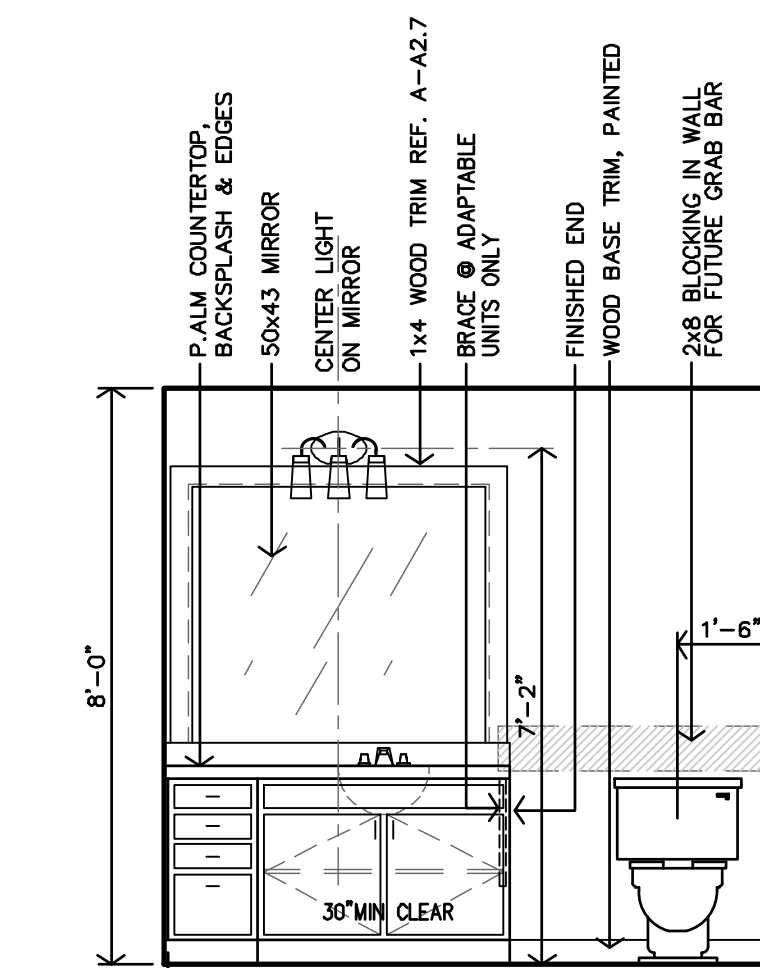

NOTE: NOT ALL BLOCKING SHOWN.

H UNITS 2B & 2C
BATH #4
INTERIOR ELEV.
3/8"=1'-0"

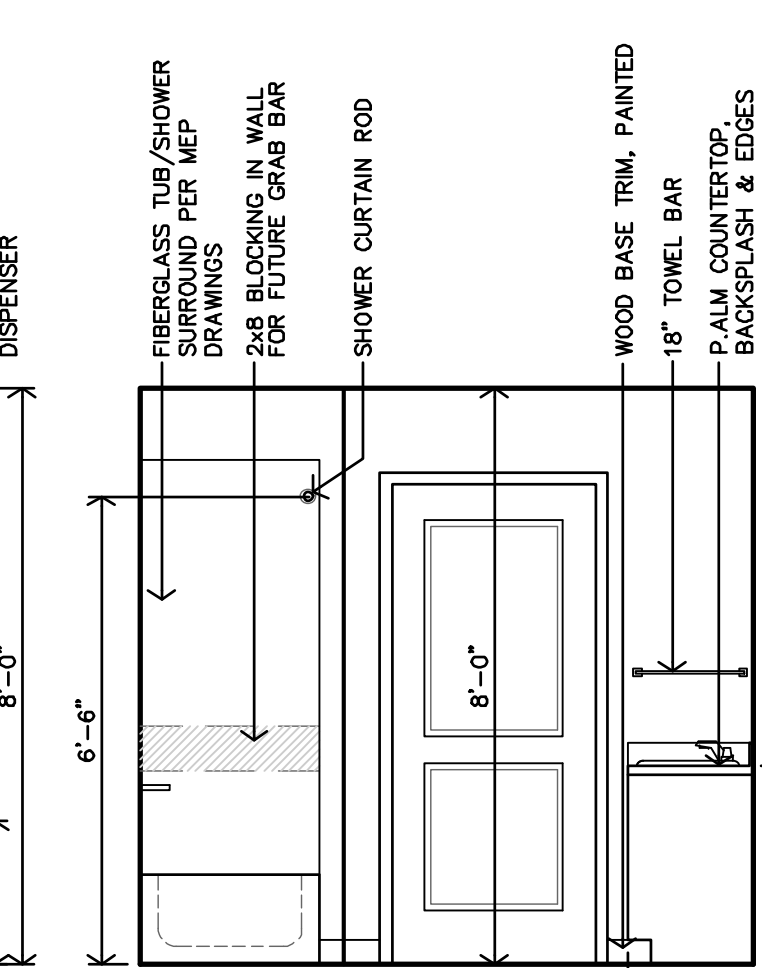

NOTE: NOT ALL BLOCKING SHOWN.

G UNITS 2B & 2C
BATH #4
INTERIOR ELEV.
3/8"=1'-0"

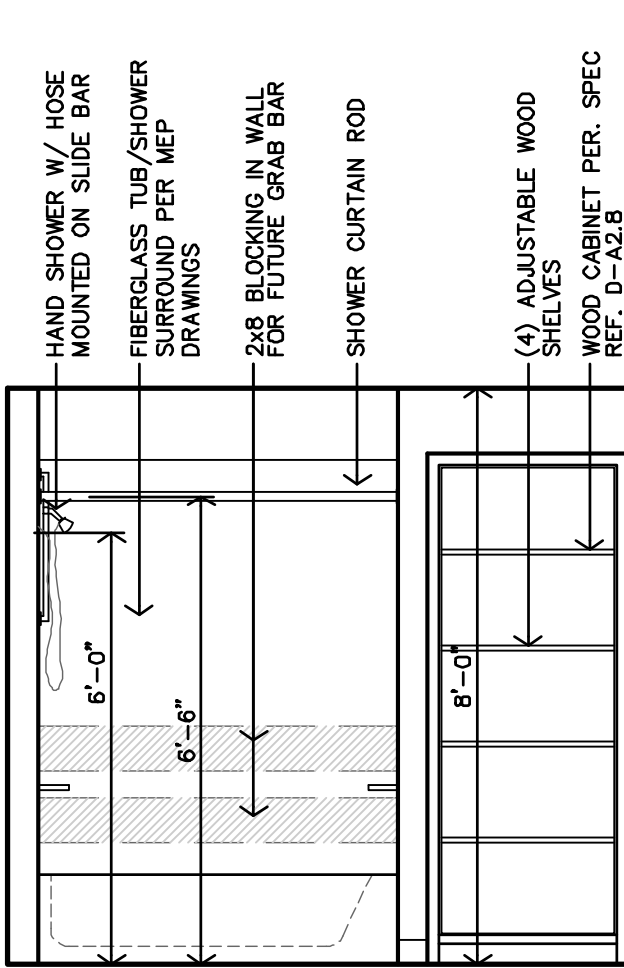

NOTE: NOT ALL BLOCKING SHOWN.

F UNITS 2B & 2C
BATH #4
INTERIOR ELEV.
3/8"=1'-0"

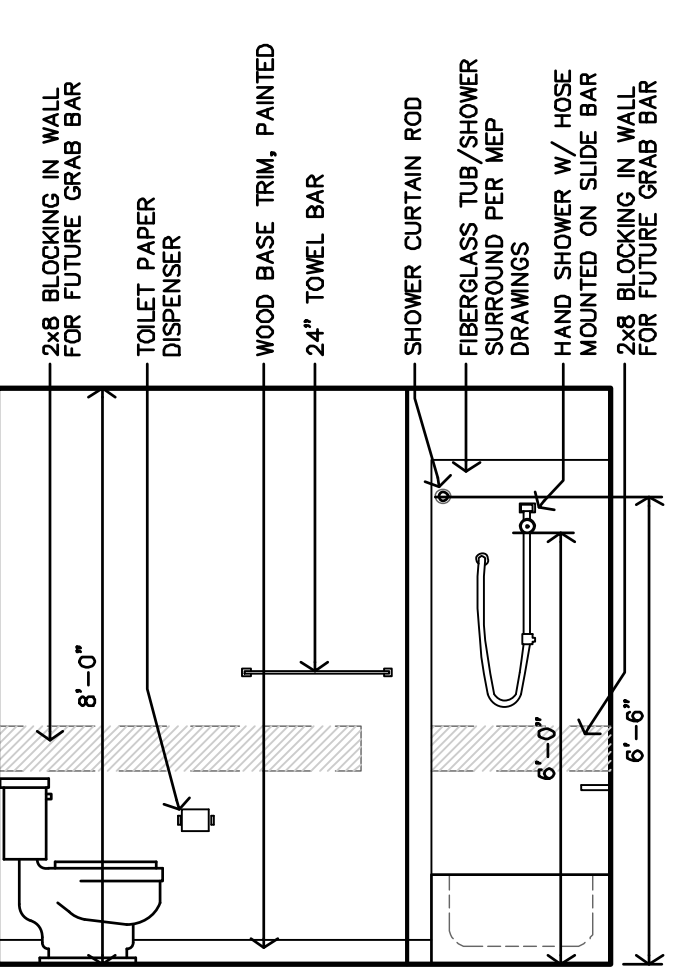

NOTE: NOT ALL BLOCKING SHOWN.

E UNITS 2B & 2C
BATH #4
INTERIOR ELEV.
3/8"=1'-0"

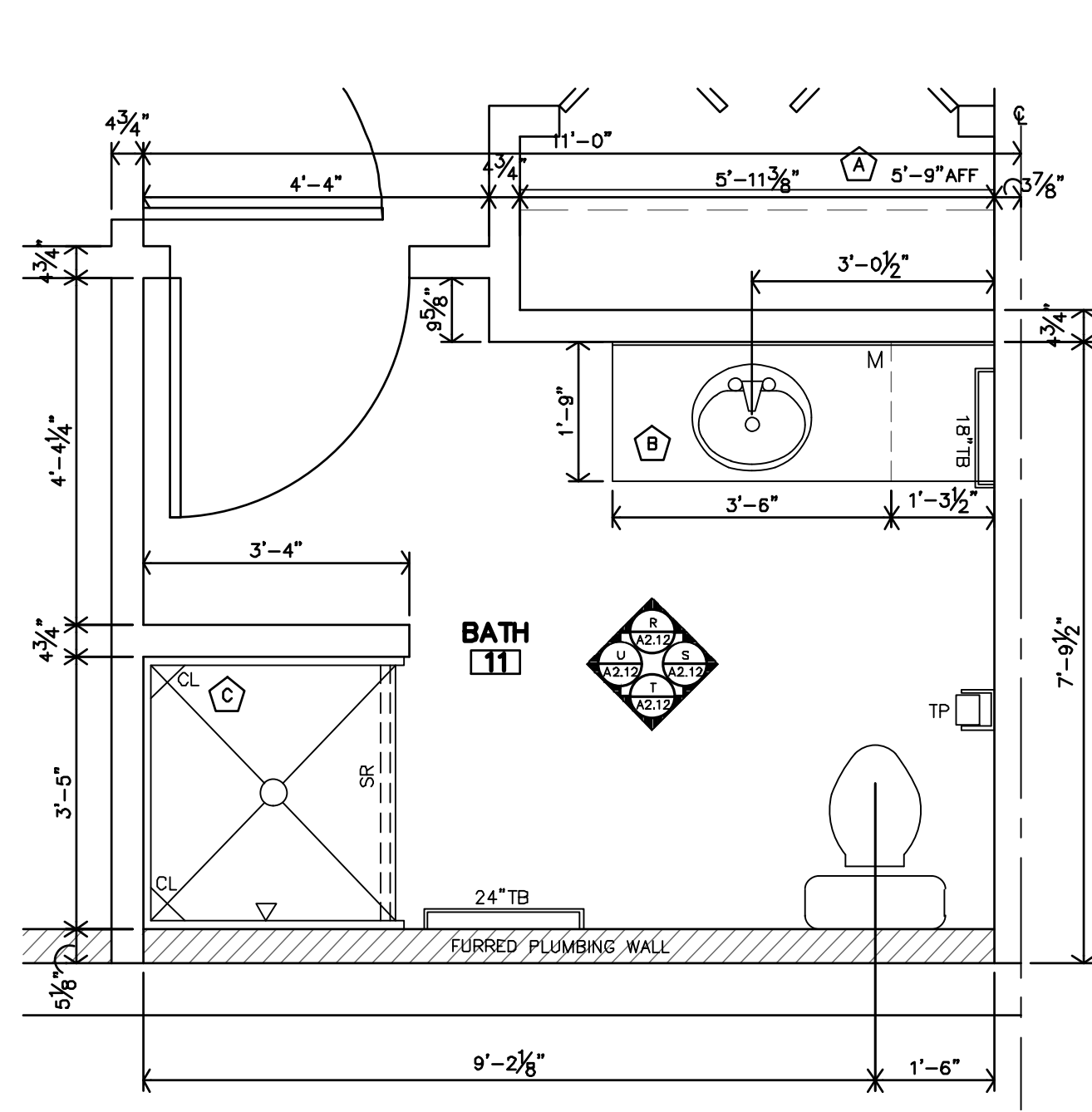

D UNITS 2D ADAPTABLE
BATH #11 ENLARGED PLAN
1/2"=1'-0"

ADAPTABLE BATH NOTES	
1. REF. APARTMENT GENERAL & ADAPTABLE UNIT NOTES ON SHEET A2.7 FOR ADDITIONAL DIRECTION.	
2. ALL DIMENSIONS ARE TO FACE OF CYP. BD. UNLESS NOTED OTHERWISE	
3. CONTRACTOR TO INSTALL 2x8 BLOCKING IN WALLS FOR ALL WALL MOUNTED/SUPPORTED COUNTERTOPS & BRACES, SHOWER UNIT, SLIDE BAR, TOWEL BARS, FUTURE GRABS BARS & FUTURE SHOWER SEAT, ETC. AS REQ'D. (REF. A2.7)	
4. SHOWER SEAT TO BE INSTALLED PER TENANT REQUEST IN ADAPTABLE UNITS.	
5. LOCATION OF WASHER & DRYER IS CRITICAL. WASHER IS TO BE LEFT OF DRYER. ALWAYS. THIS NEEDS TO BE COORDINATED ON SITE.	
6. F.O.S. = FACE OF STUD	

LEGEND	KEYNOTES:
M MIRROR	⊠ PLASTIC COATED WIRE CLOTHES SHELF & ROD (HEIGHT AS CALLED OUT ON PLAN)
TP TOILET PAPER DISPENSER	⊞ FLOORING TO BE CONTINUOUS @ REMOVABLE CABINETS
TB TOWEL BAR	⊞ VERIFY SIZE w/ SHOWER UNIT
CL CORNER LEDGE	⊞ WATER HEATER - REF. MECH. DRAWINGS
SR SHOWER ROD	

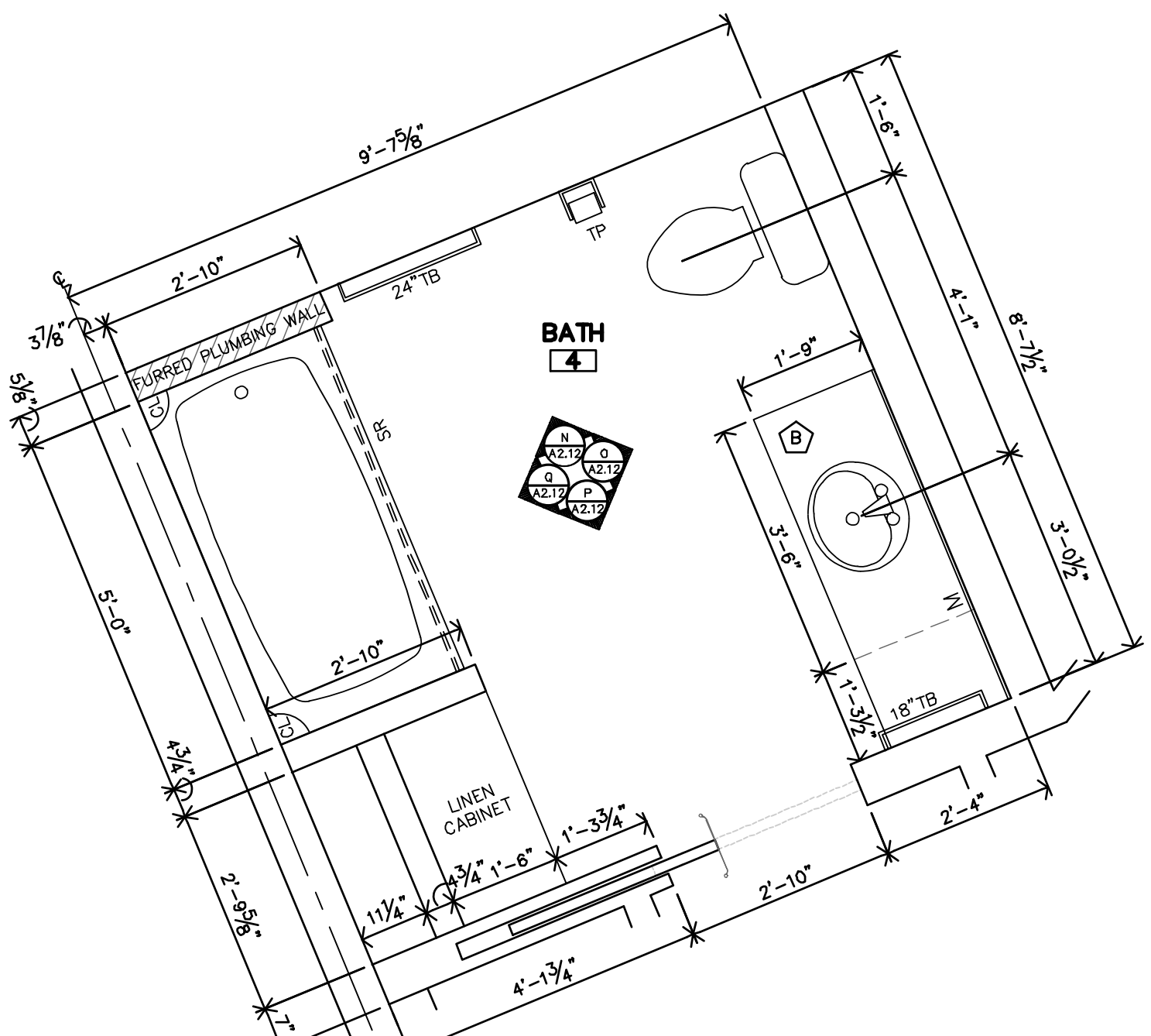

C UNITS 2D ADAPTABLE
BATH #4 ENLARGED PLAN
1/2"=1'-0"

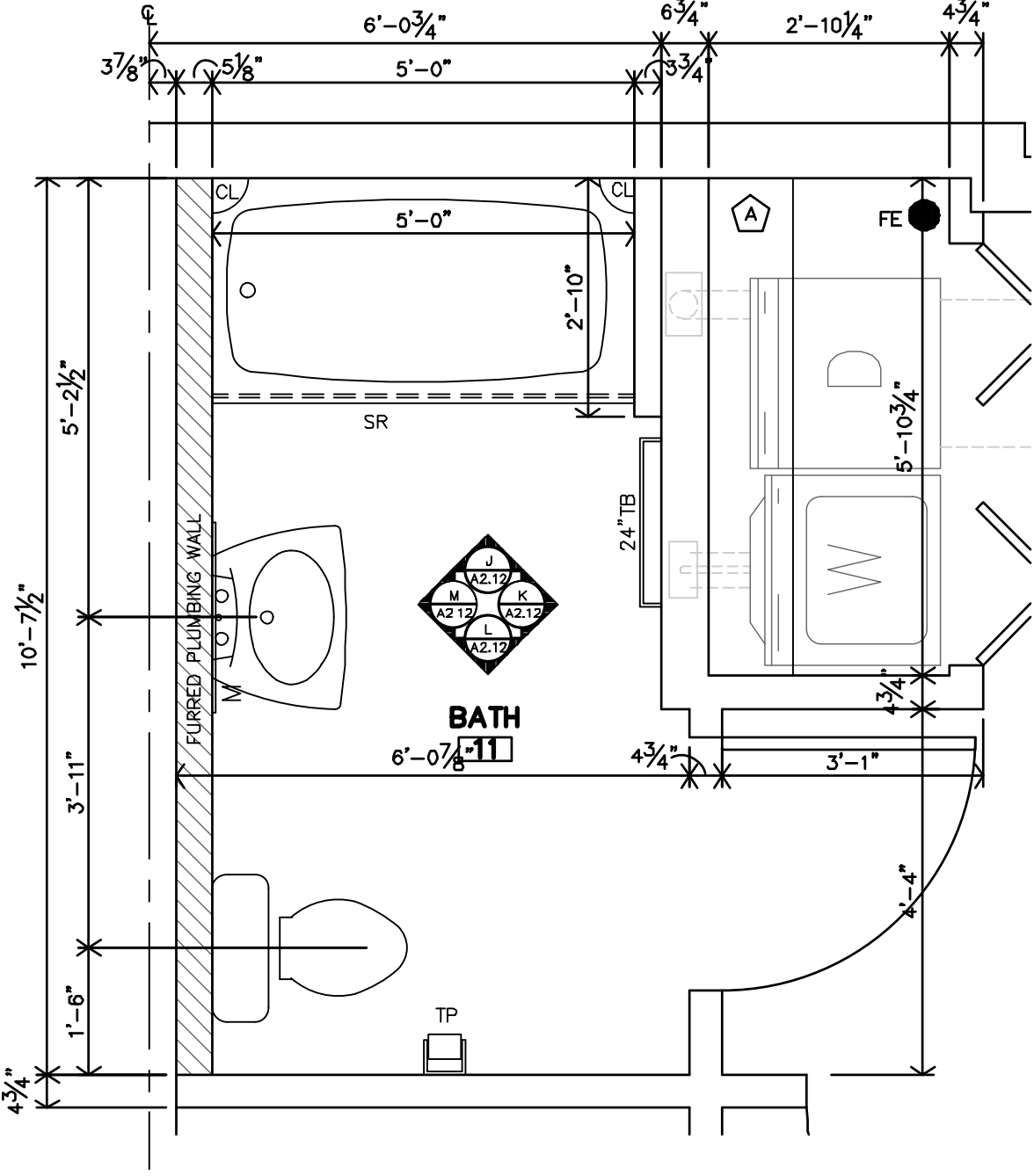

B UNITS 2B & 2C ADAPTABLE
BATH #11 ENLARGED PLAN
1/2"=1'-0"

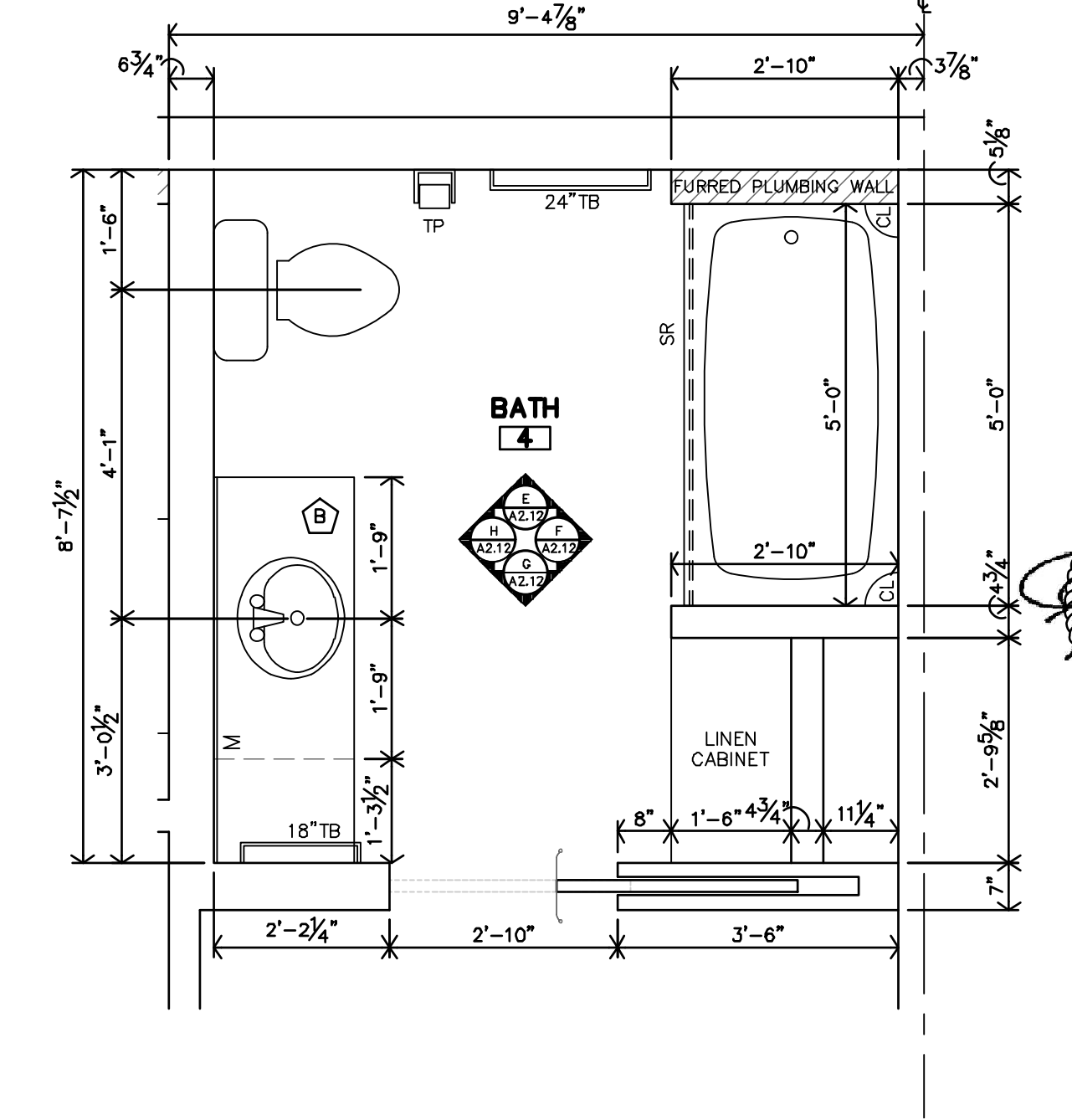

A UNITS 2B & 2C ADAPTABLE
BATH #4 ENLARGED PLAN
1/2"=1'-0"

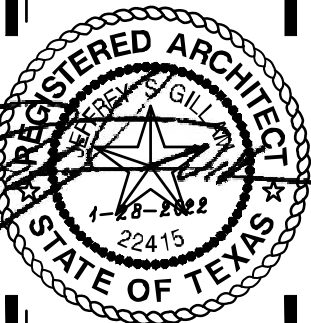

REVISION:	
DATE:	1-28-2022
JOB:	21-3137
SHEET:	

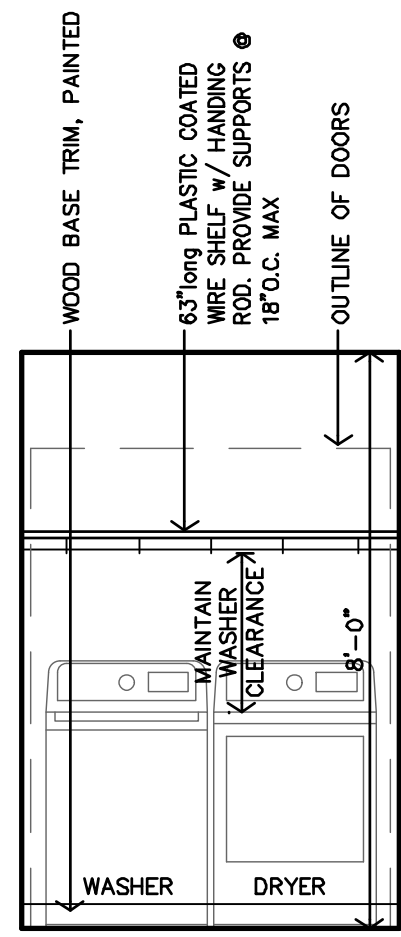

H UNITS 3B LAUNDRY #6
INTERIOR ELEV.
3/8"=1'-0"

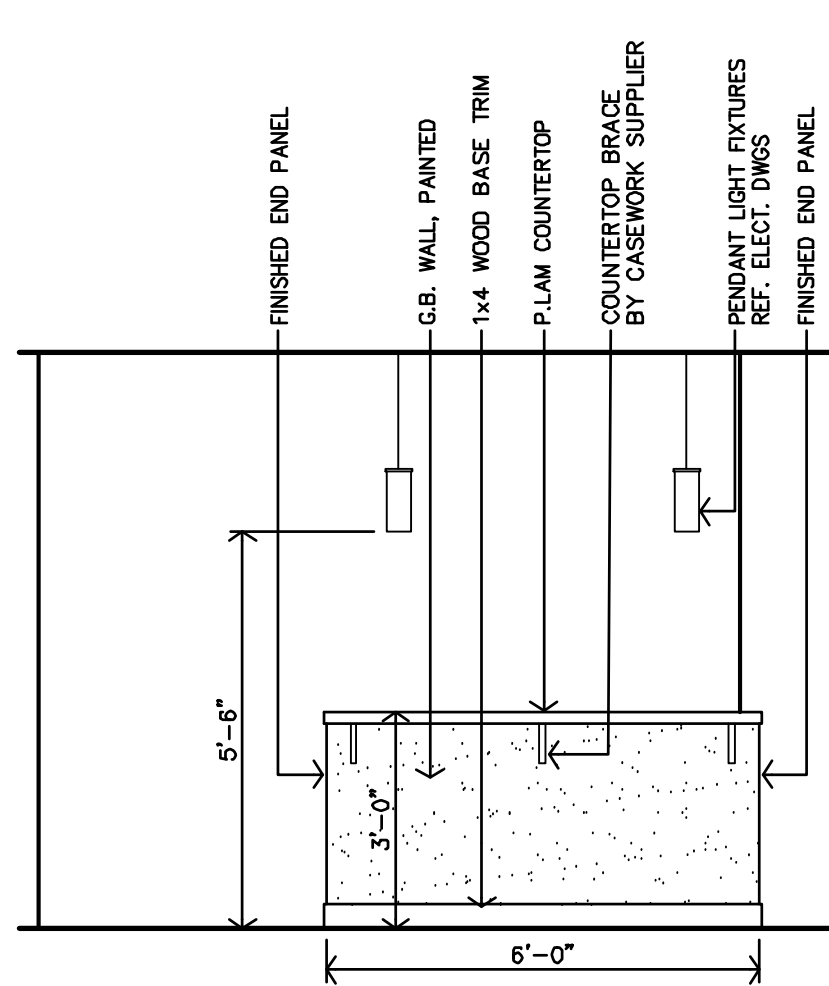

G UNITS 3B KITCHEN #3
INTERIOR ELEV.
3/8"=1'-0"

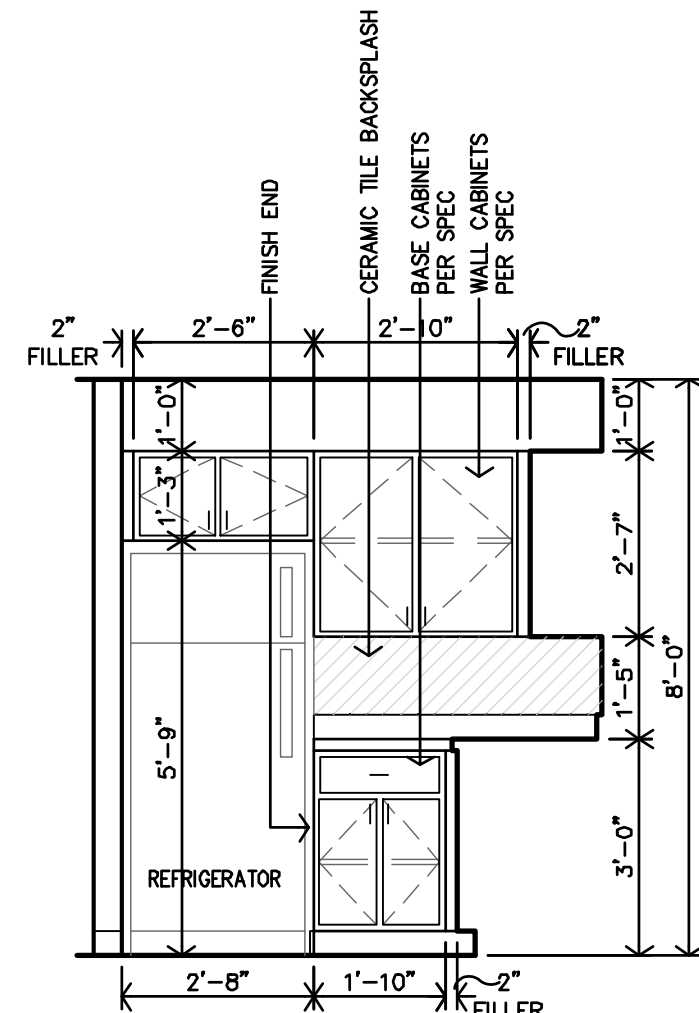

F UNITS 3B KITCHEN #3
INTERIOR ELEV.
3/8"=1'-0"

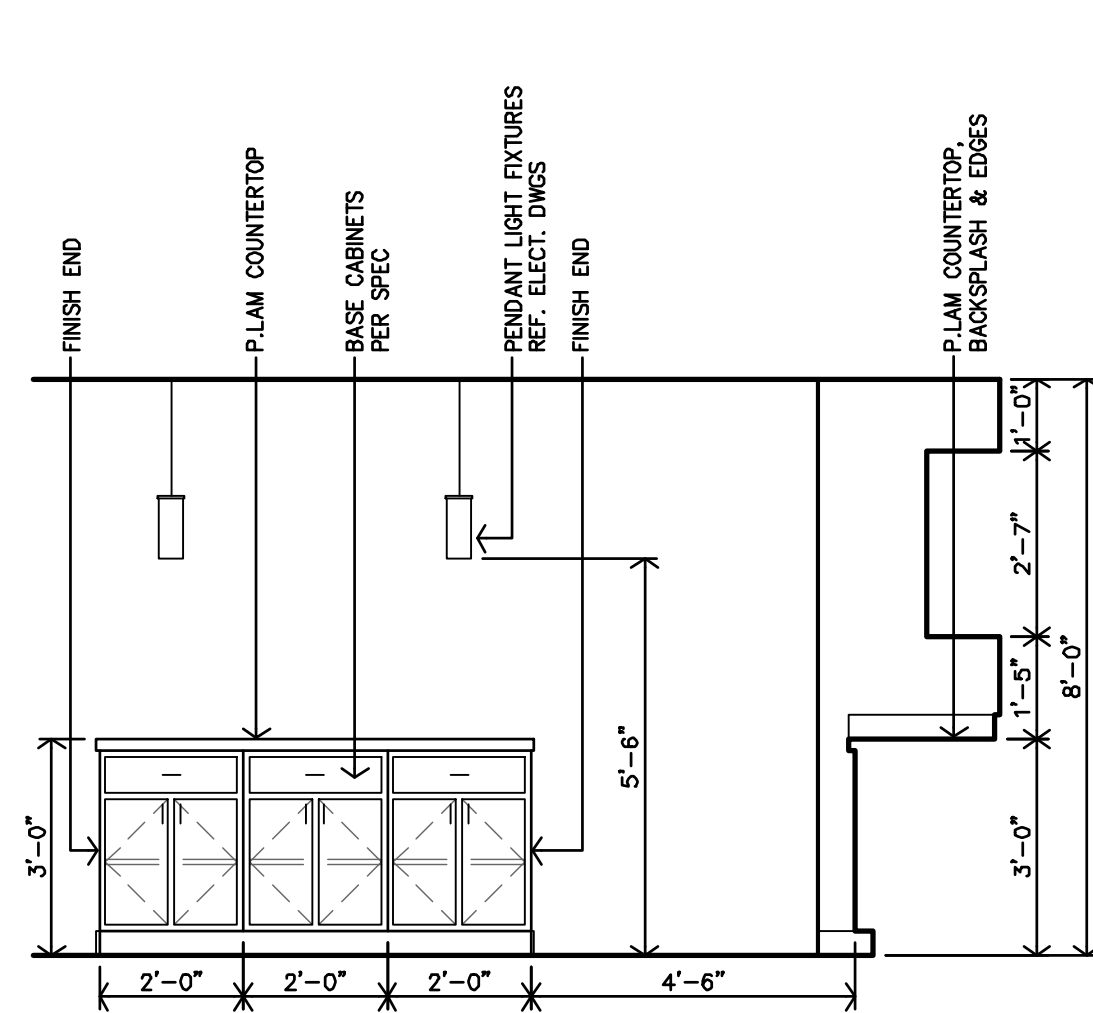

E UNITS 3B KITCHEN #3
INTERIOR ELEV.
3/8"=1'-0"

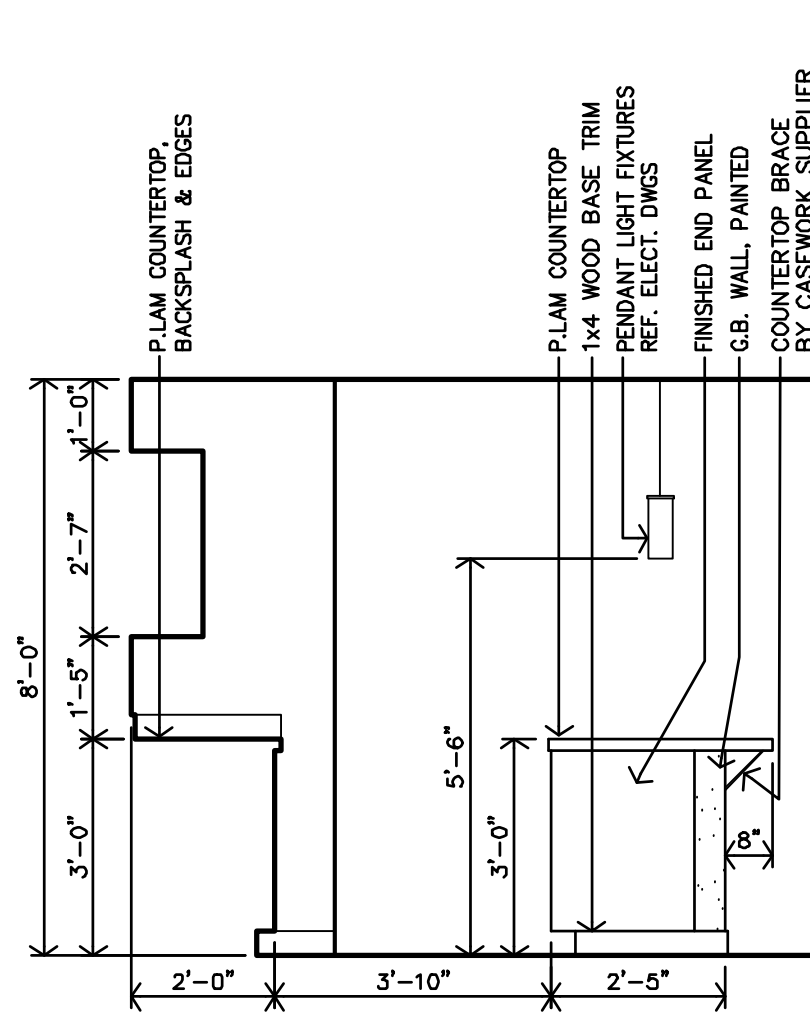

D UNITS 3B KITCHEN #3
INTERIOR ELEV.
3/8"=1'-0"

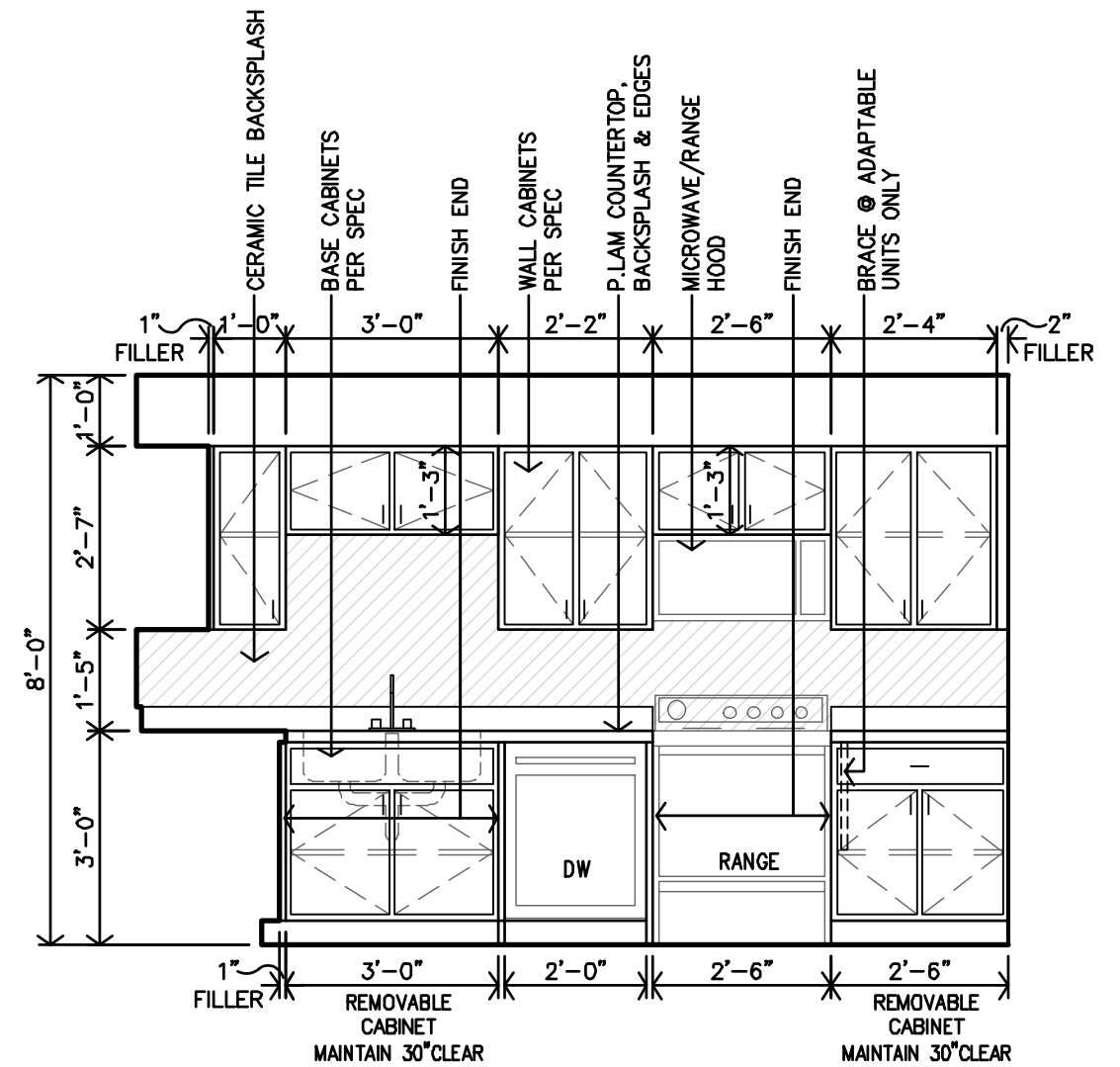

C UNITS 3B KITCHEN #3
INTERIOR ELEV.
3/8"=1'-0"

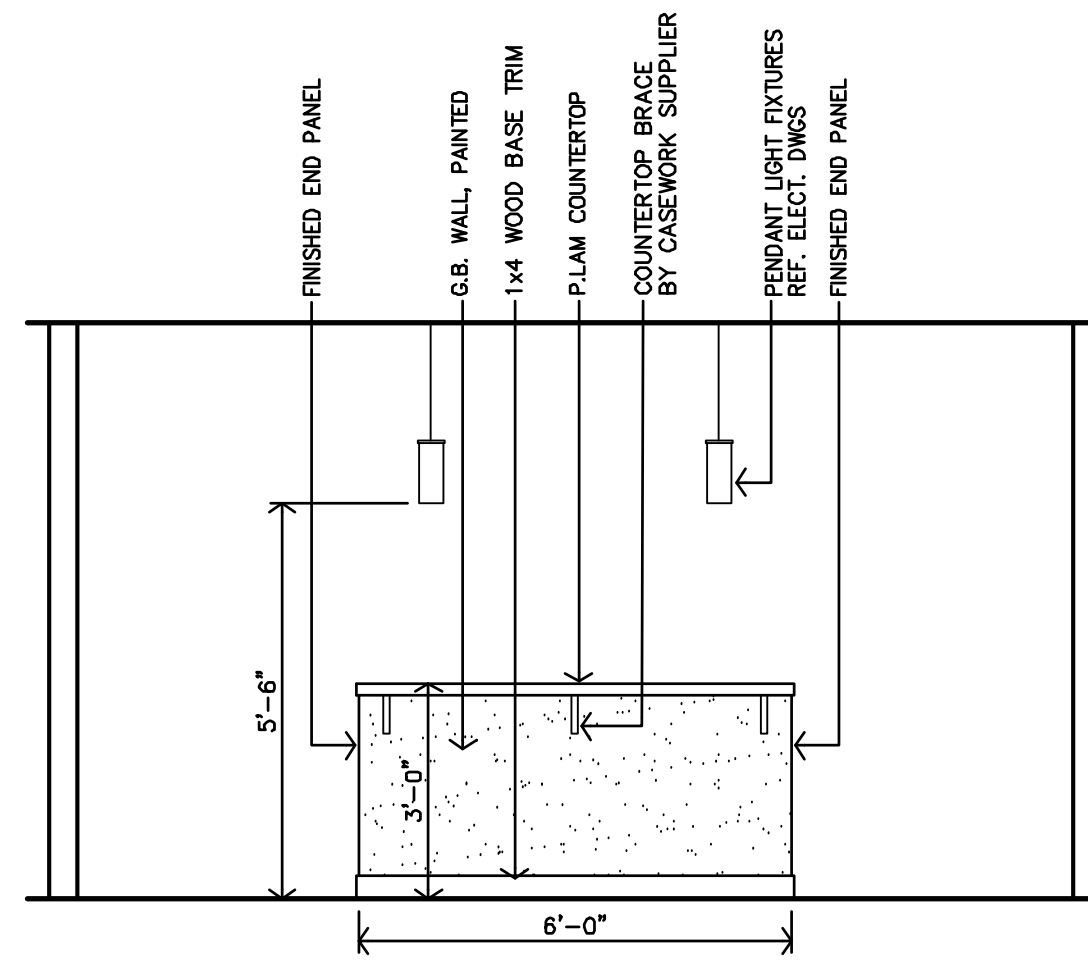

N UNITS 3B & 3C KITCHEN #3
INTERIOR ELEV.
3/8"=1'-0"

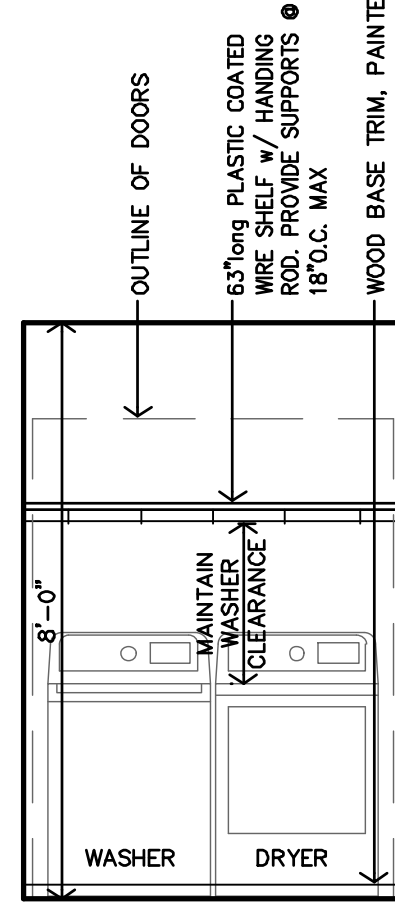

M UNITS 3C LAUNDRY #6
INTERIOR ELEV.
3/8"=1'-0"

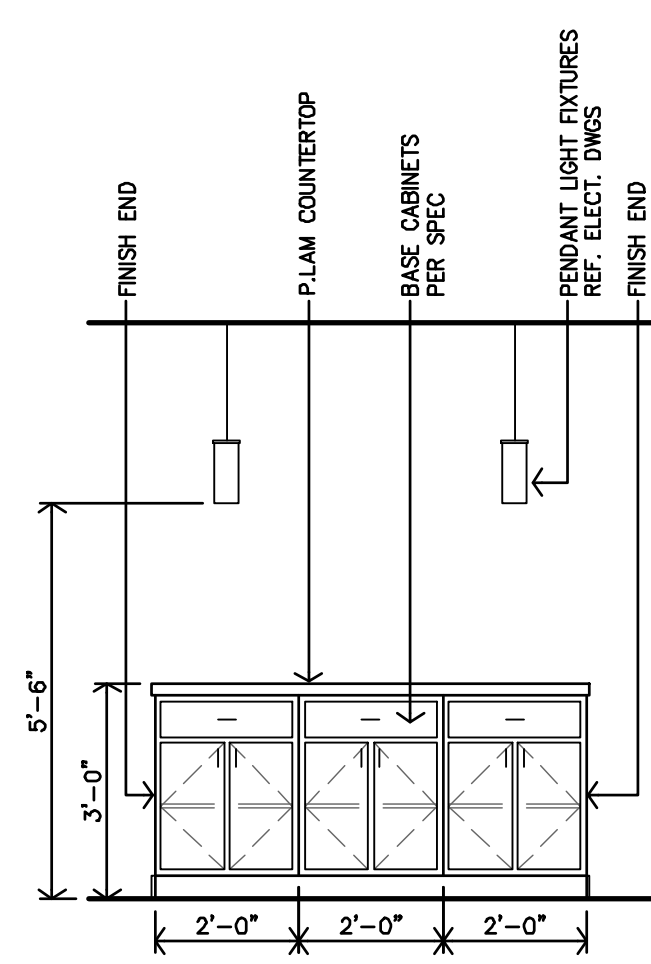

L UNITS 3C KITCHEN #3
INTERIOR ELEV.
3/8"=1'-0"

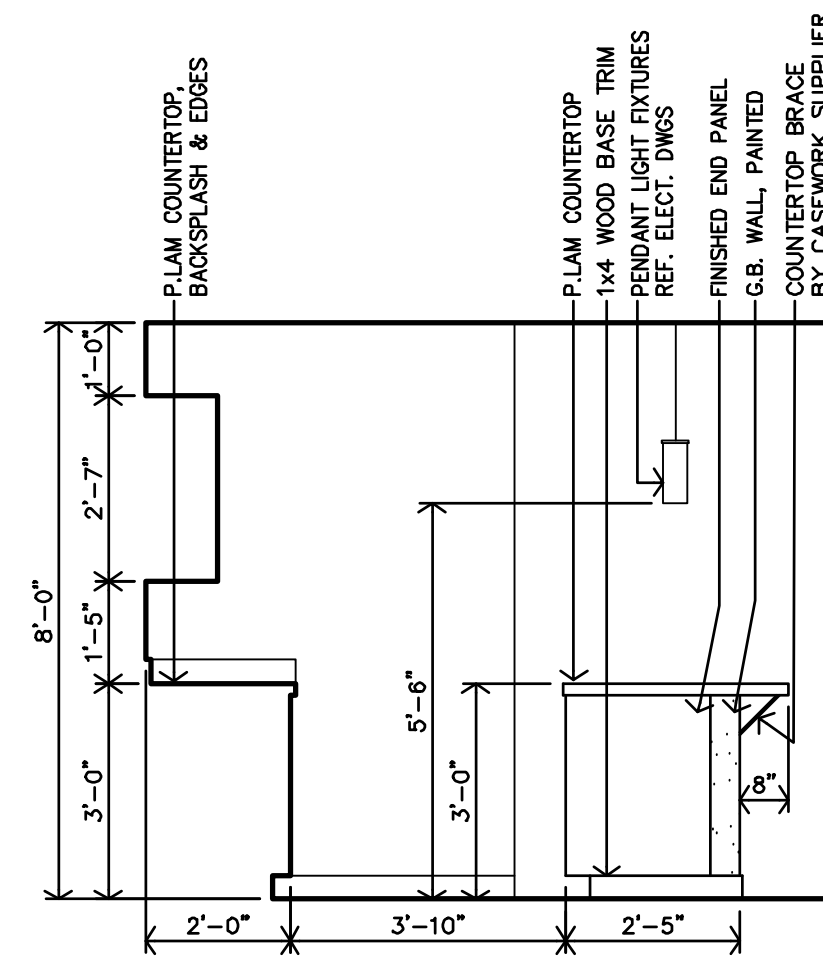

K UNITS 3C KITCHEN #3
INTERIOR ELEV.
3/8"=1'-0"

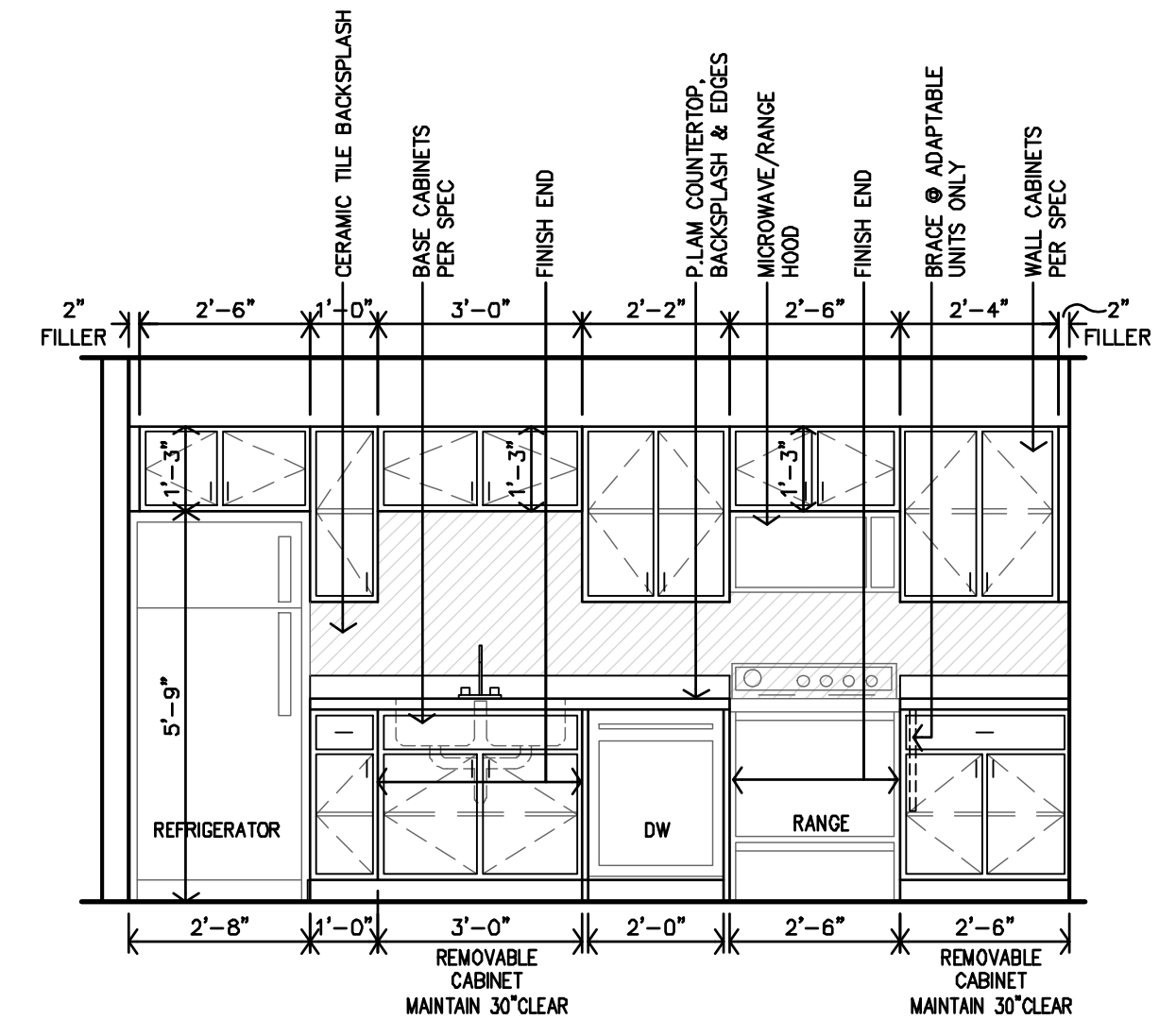

J UNITS 3C KITCHEN #3
INTERIOR ELEV.
3/8"=1'-0"

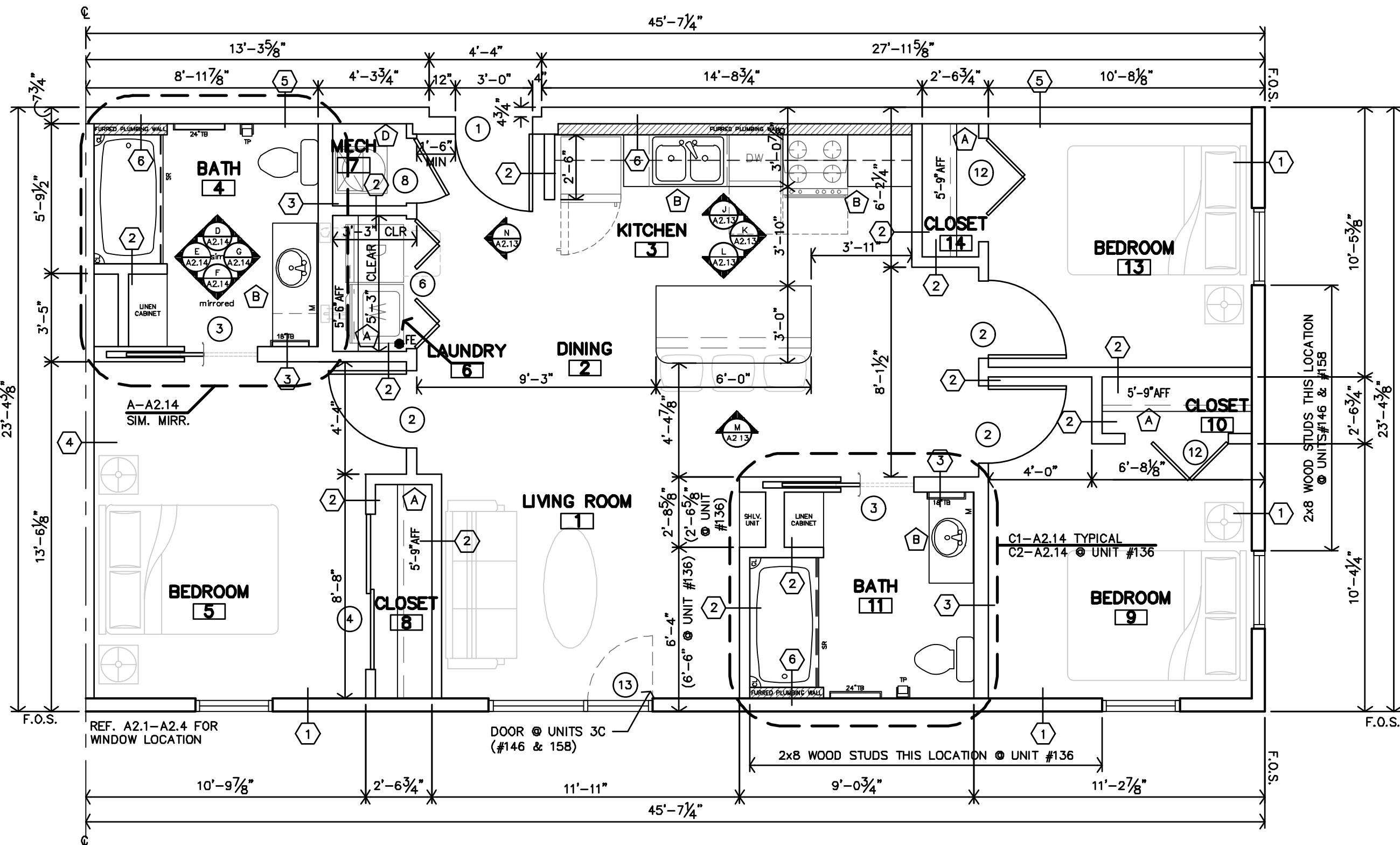

B UNIT 3C ADAPTABLE
3 BEDROOM - 2 BATH UNIT PLAN
1/4"=1'-0"

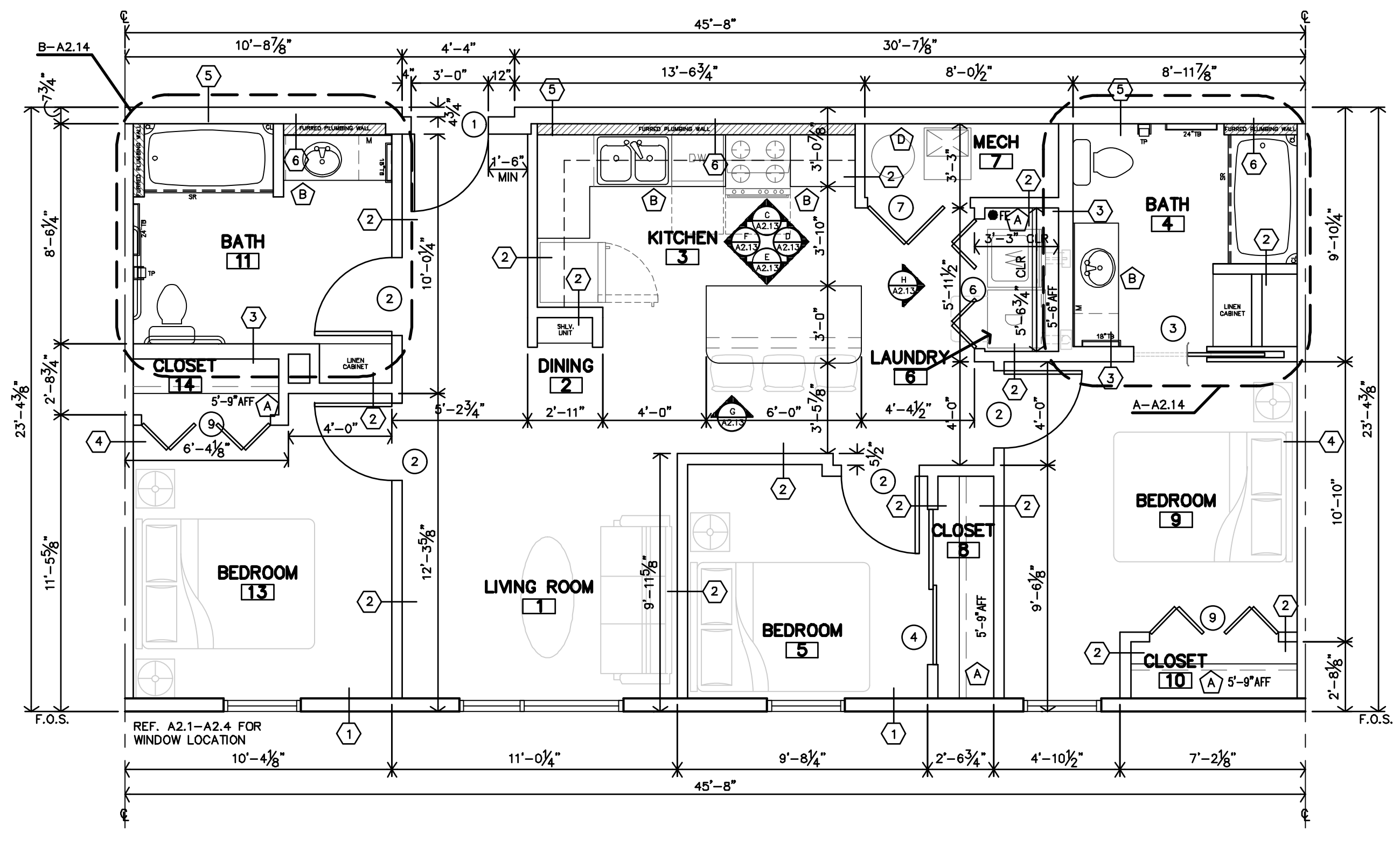

A UNIT 3B ADAPTABLE
3 BEDROOM - 2 BATH UNIT PLAN
1/4"=1'-0"



REVISION:	
DATE:	1-28-2022
JOB:	21-3137
SHEET:	

A2.13

CLIFTON RIVERSIDE APARTMENTS
NEW APARTMENTS
FORT WORTH, TEXAS

Architects Planners Designers
1880 North Street, Suite 301
P.O. Box 28208
Selling, KS 67402
jgr@jgrarchitects.com
785.827.0386

COPYRIGHTED ©

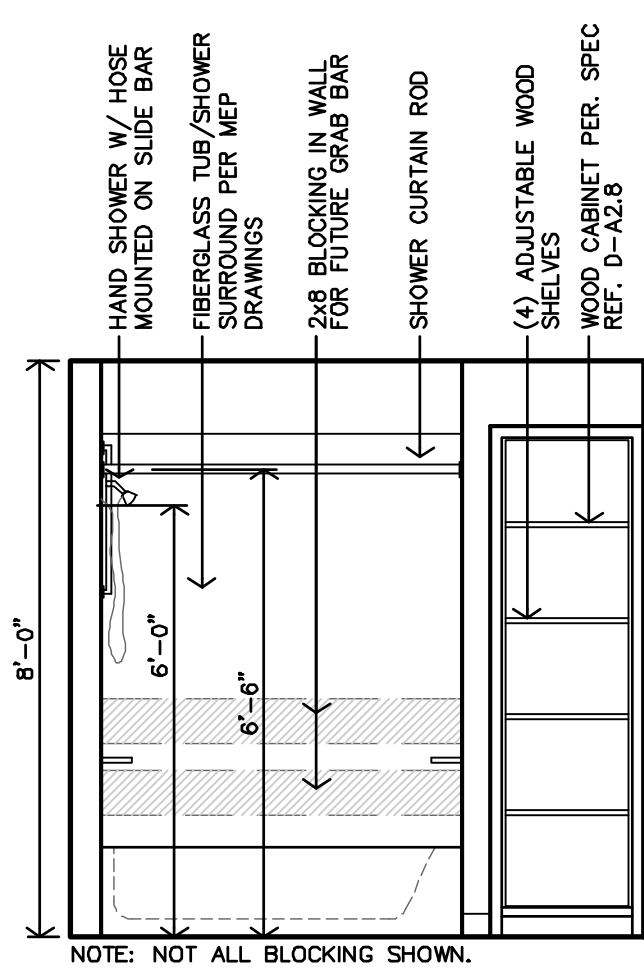

P UNITS 3C - BATH #11 INTERIOR ELEV.
3/8"=1'-0"

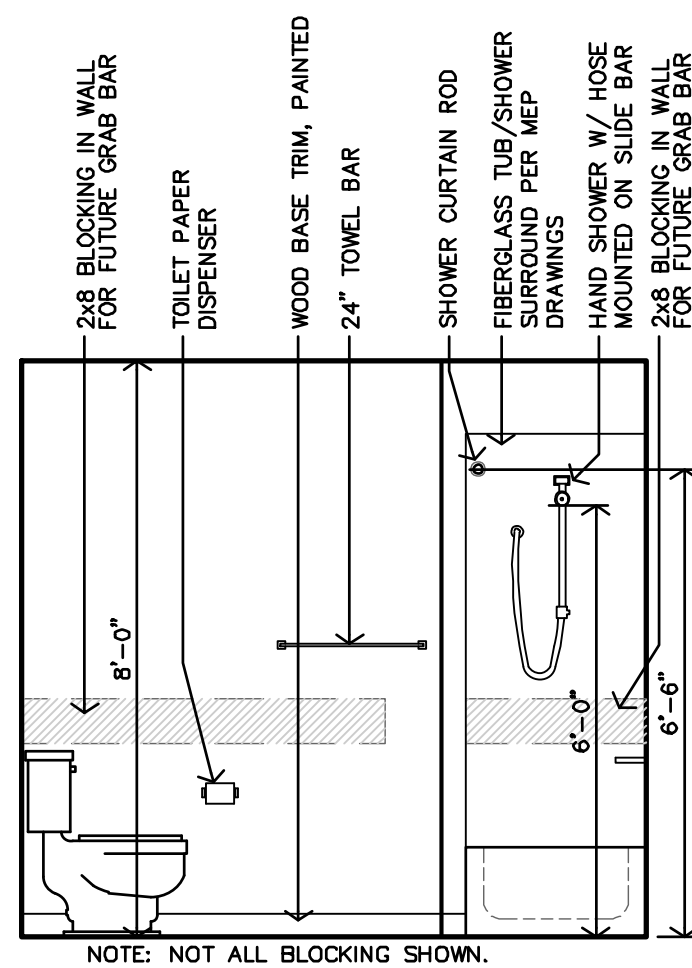

O UNITS 3C - BATH #11 INTERIOR ELEV.
3/8"=1'-0"

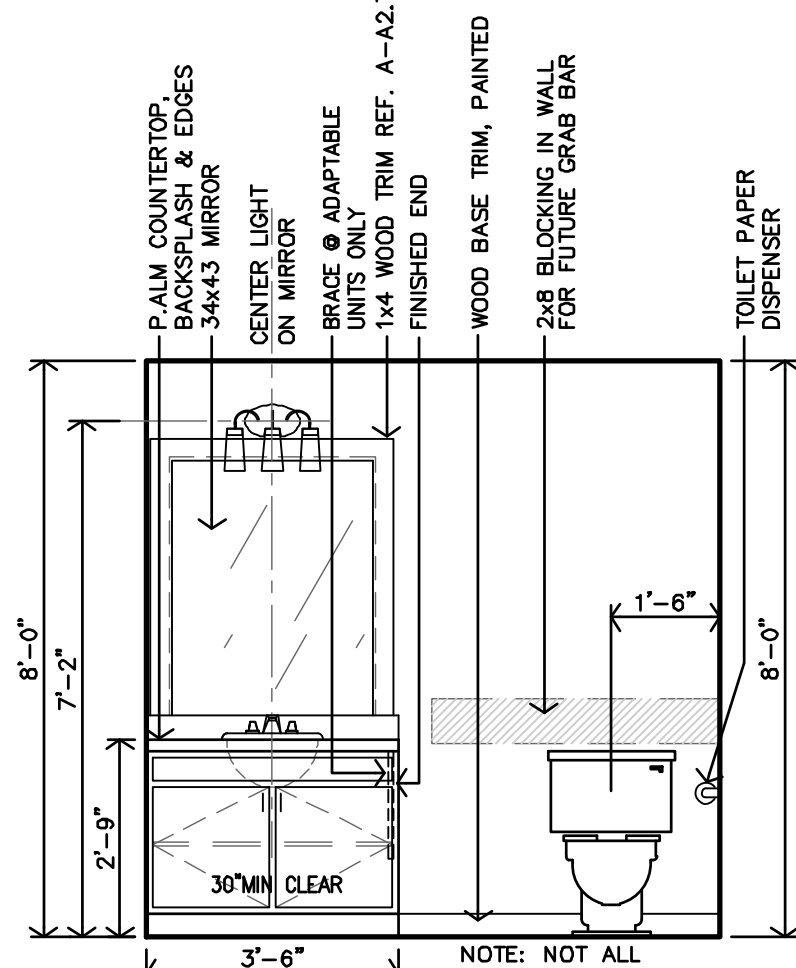

N UNITS 3C - BATH #11 INTERIOR ELEV.
3/8"=1'-0"

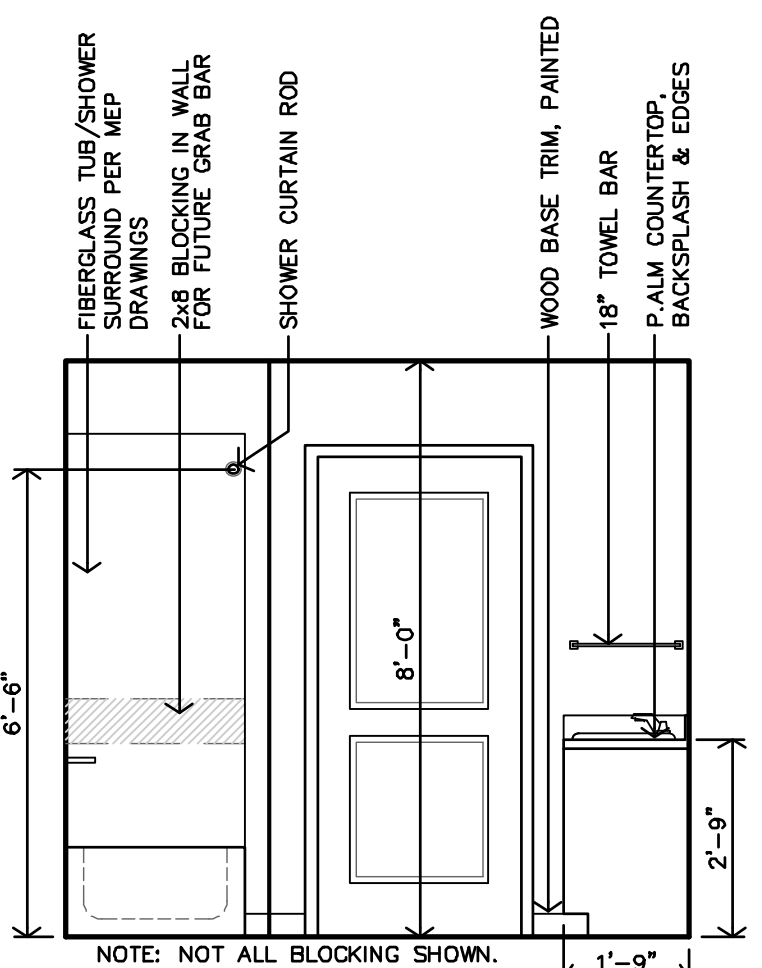

M UNITS 3C - BATH #11 INTERIOR ELEV.
3/8"=1'-0"

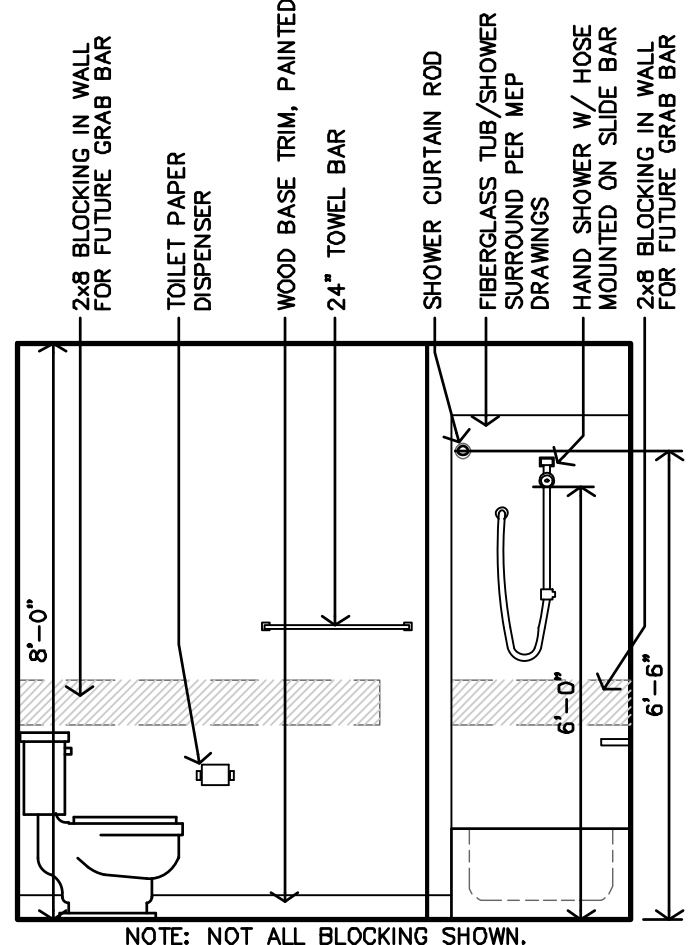

L UNITS 3B - BATH #11 INTERIOR ELEV.
3/8"=1'-0"

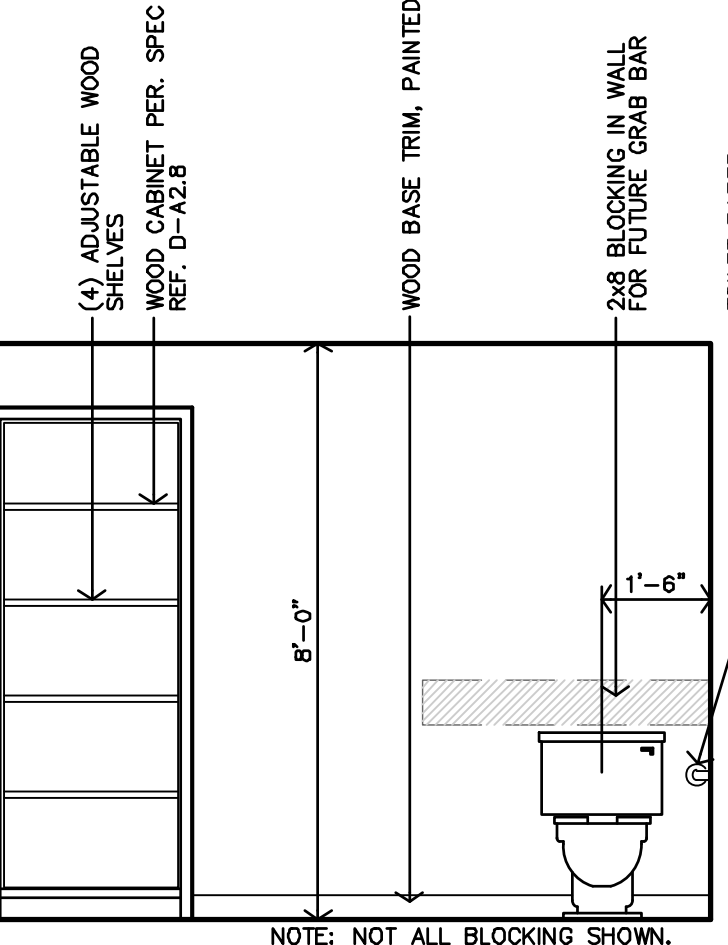

K UNITS 3B - BATH #11 INTERIOR ELEV.
3/8"=1'-0"

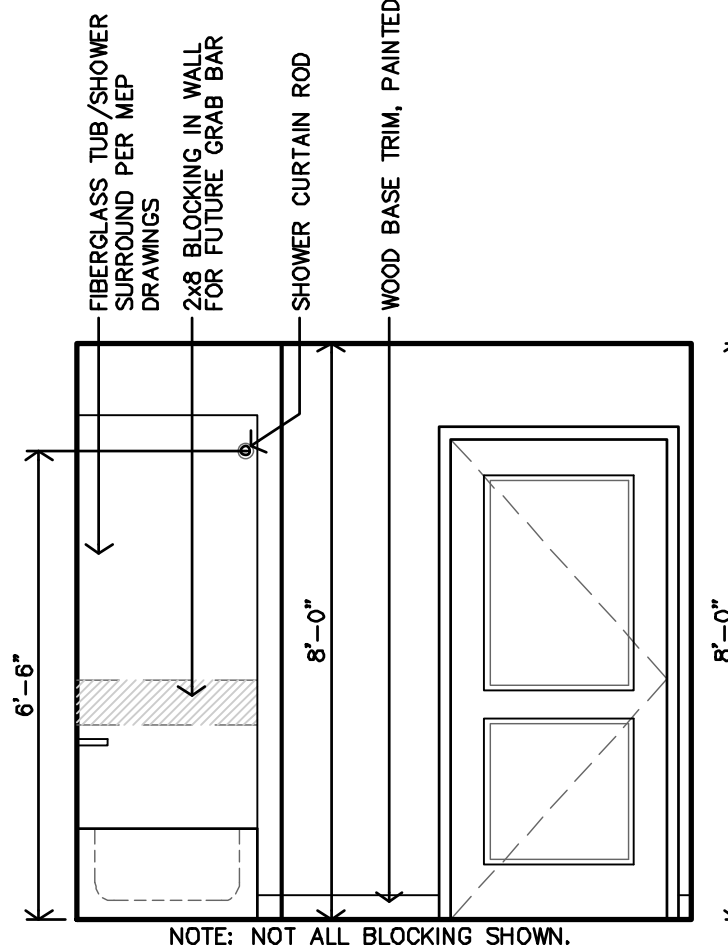

J UNITS 3B - BATH #11 INTERIOR ELEV.
3/8"=1'-0"

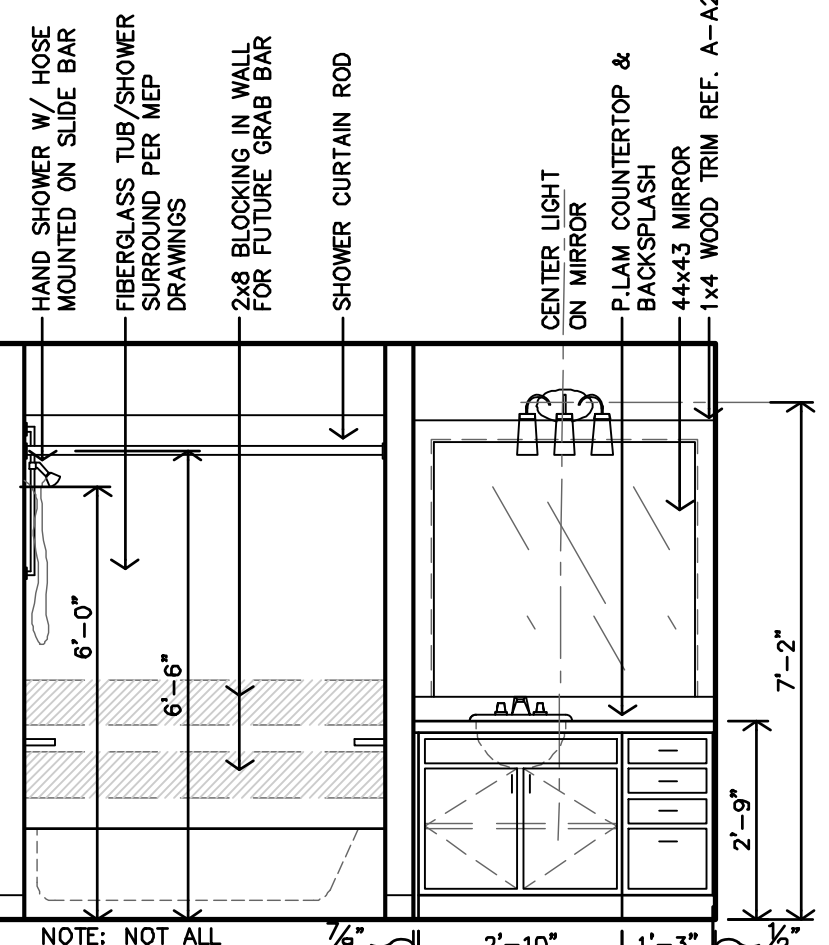

H UNITS 3B - BATH #11 INTERIOR ELEV.
3/8"=1'-0"

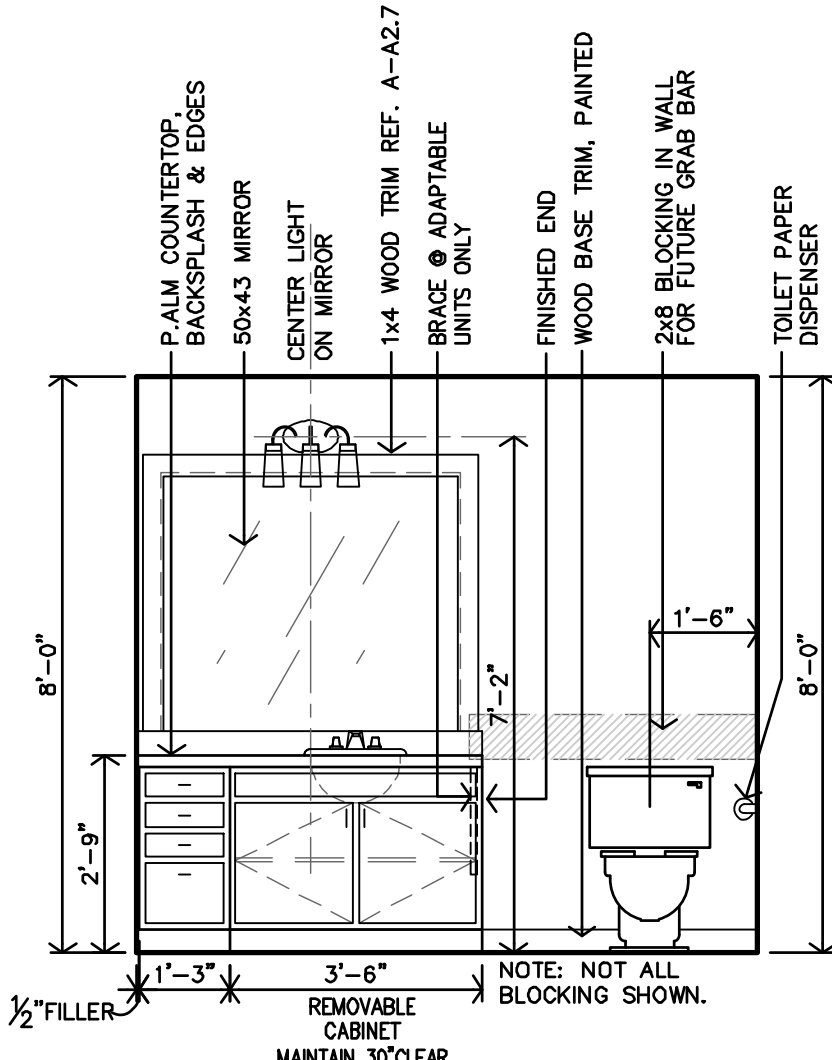

G UNITS 3B - BATH #4 INTERIOR ELEV.
3/8"=1'-0"

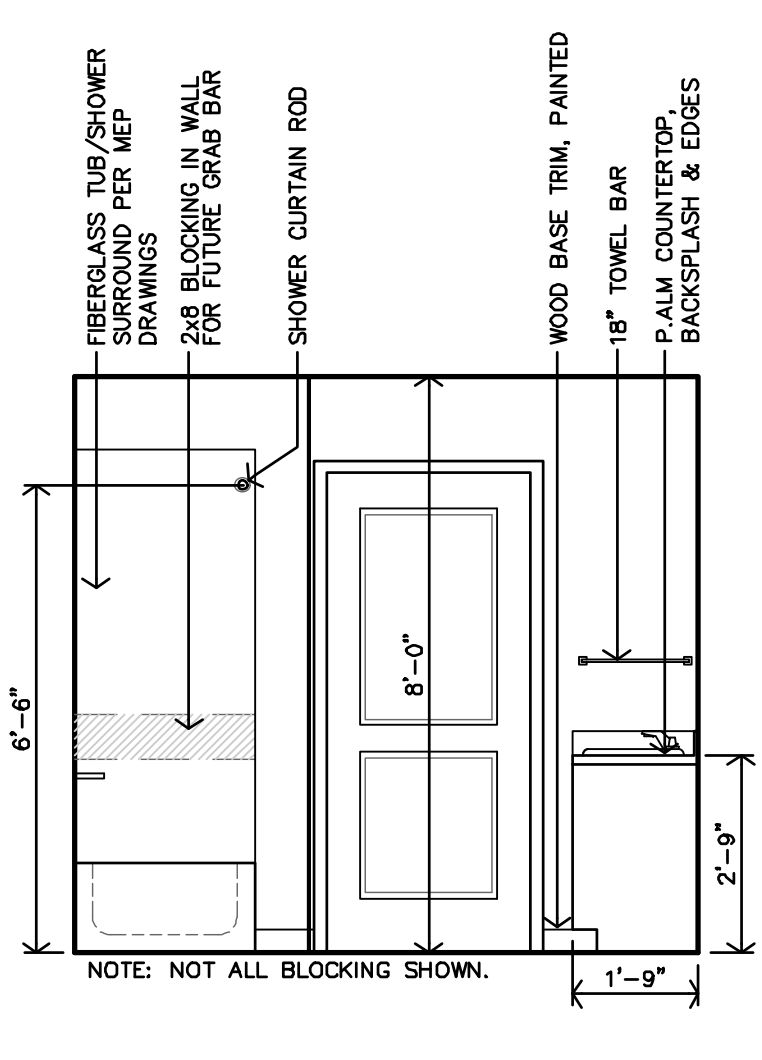

F UNITS 3B - BATH #4 INTERIOR ELEV.
3/8"=1'-0"

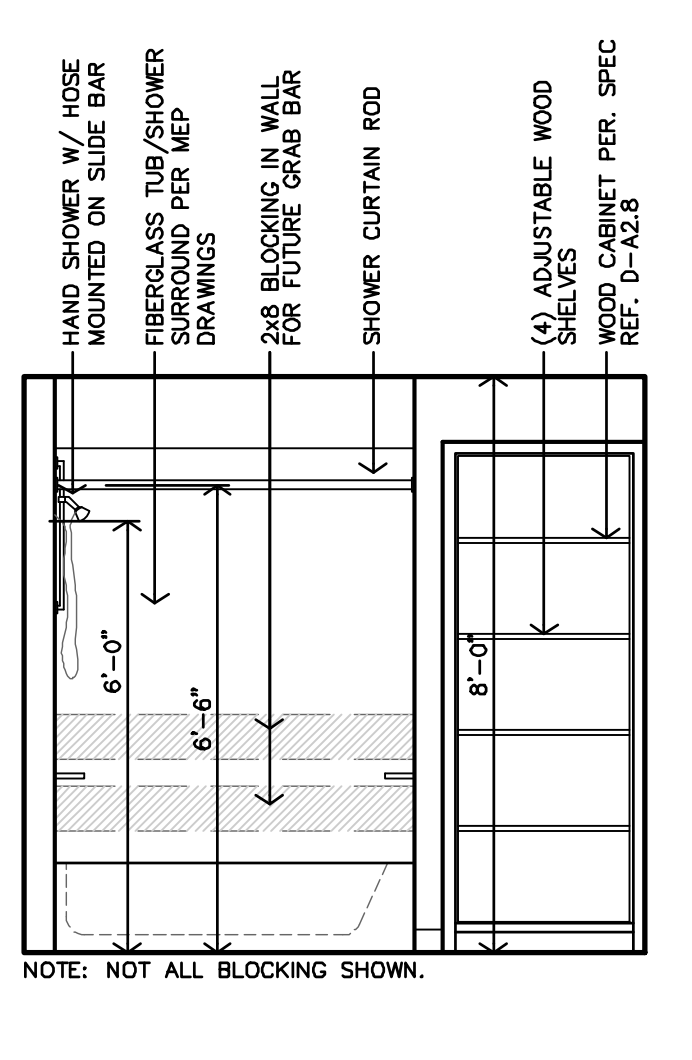

E UNITS 3B - BATH #4 INTERIOR ELEV.
3/8"=1'-0"

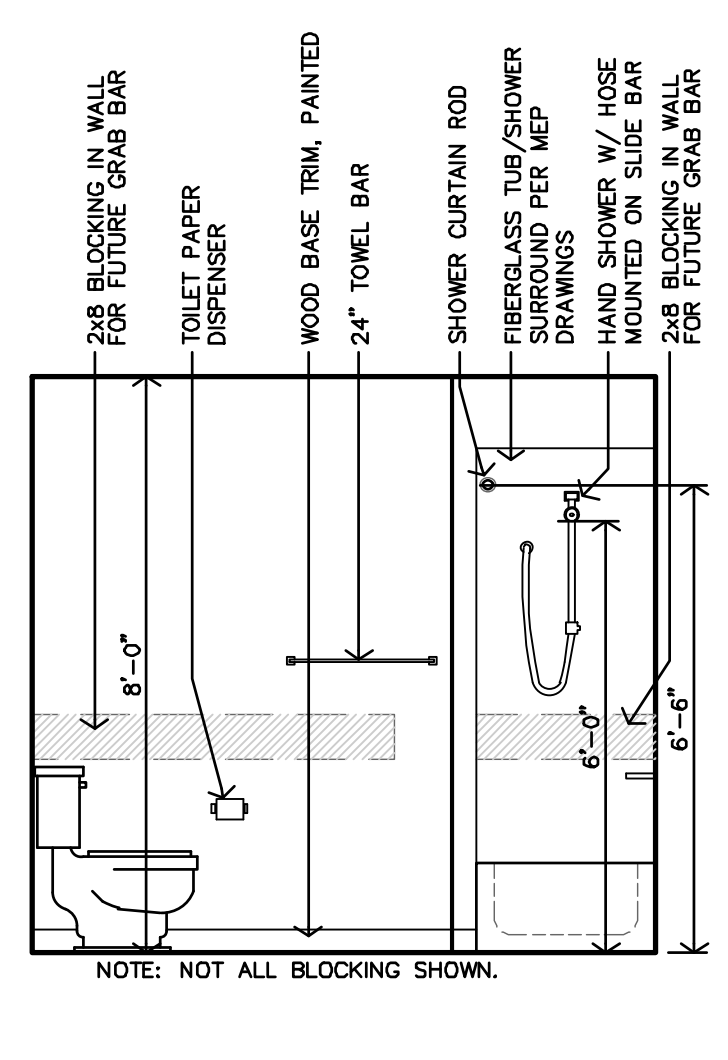

D UNITS 3B - BATH #4 INTERIOR ELEV.
3/8"=1'-0"

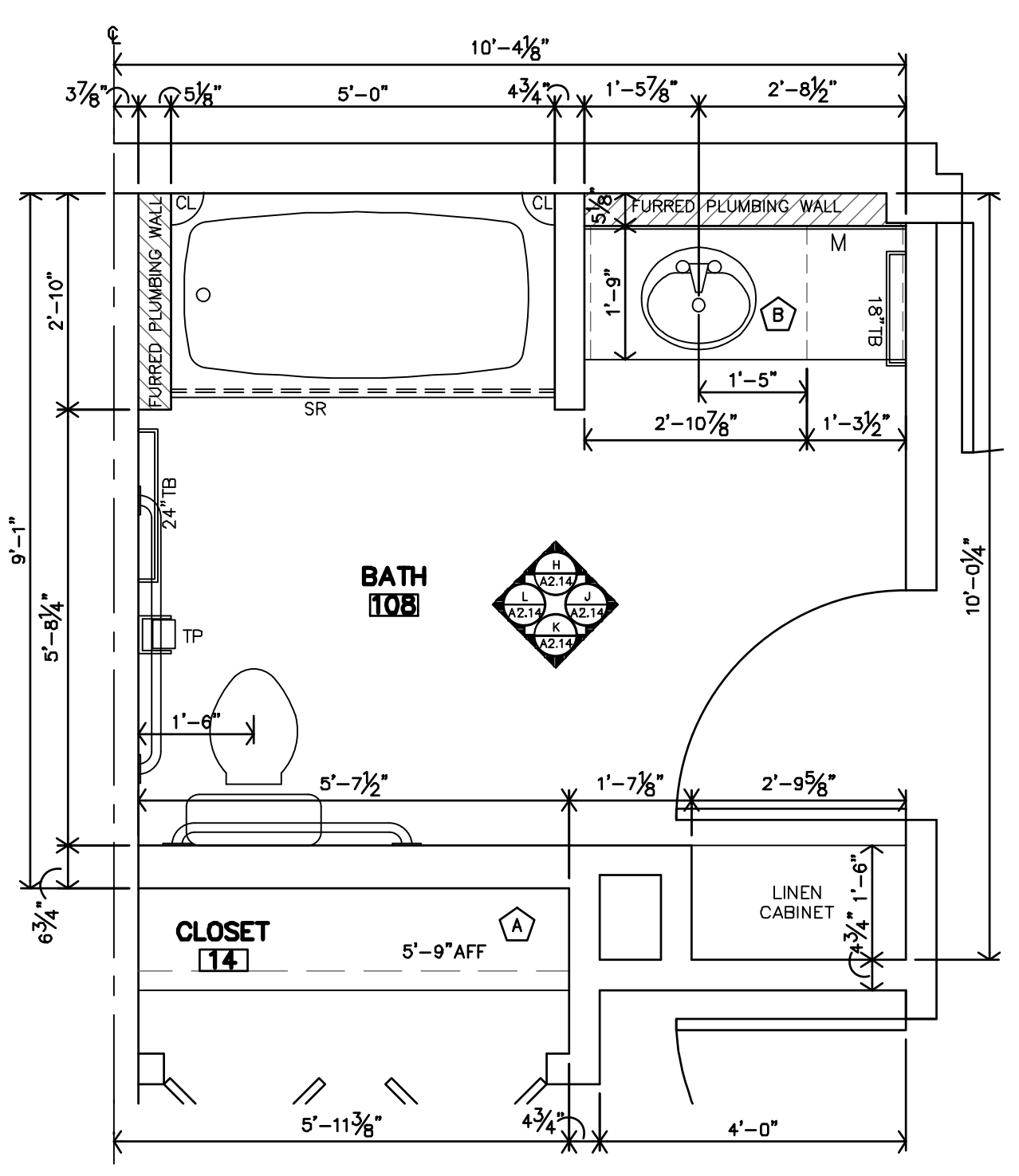

B UNIT 3B ADAPTABLE BATH #11 ENLARGED PLAN
1/2"=1'-0"

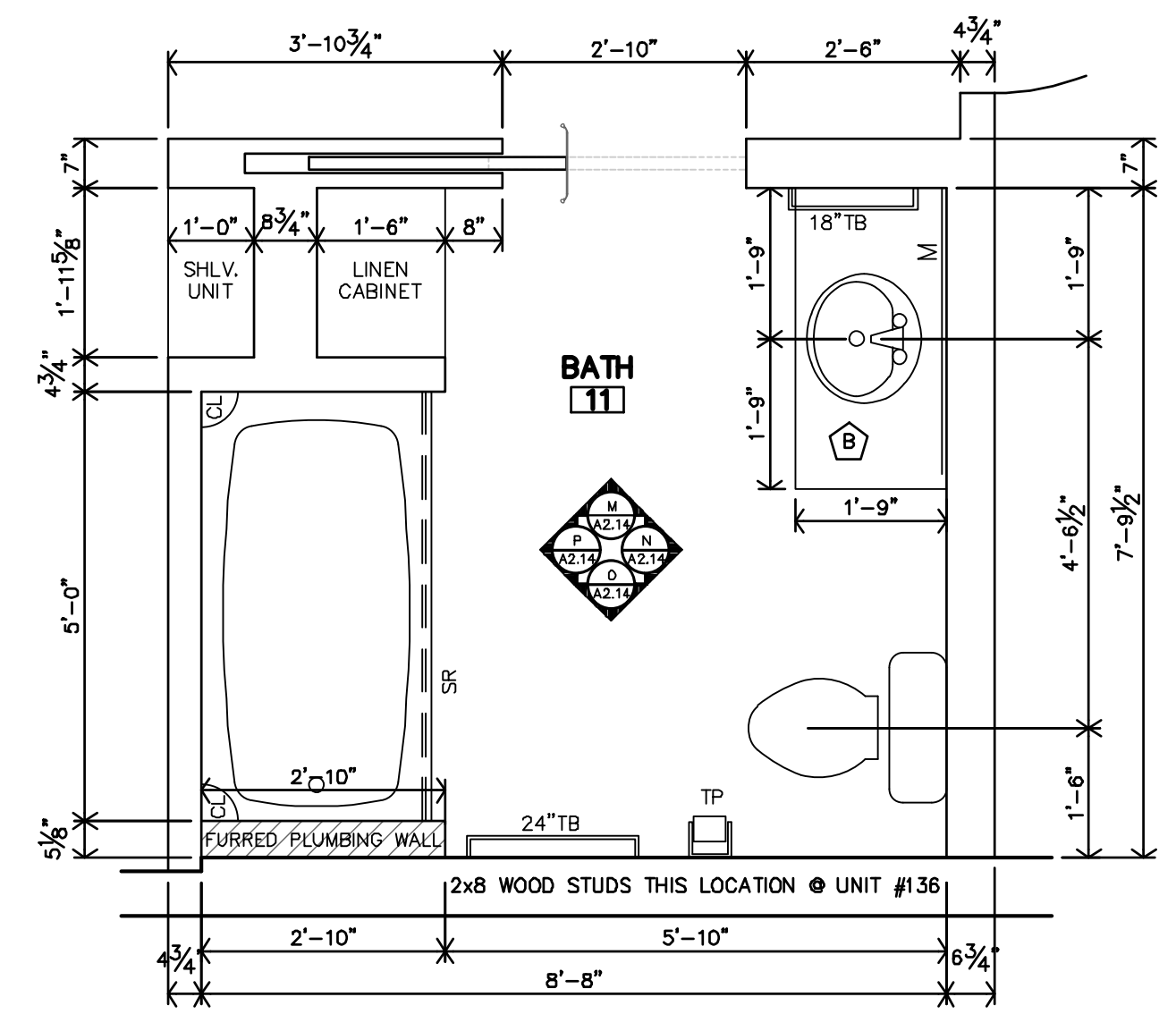

C2 UNIT #136 BATH #11 ENLARGED PLAN
1/2"=1'-0"

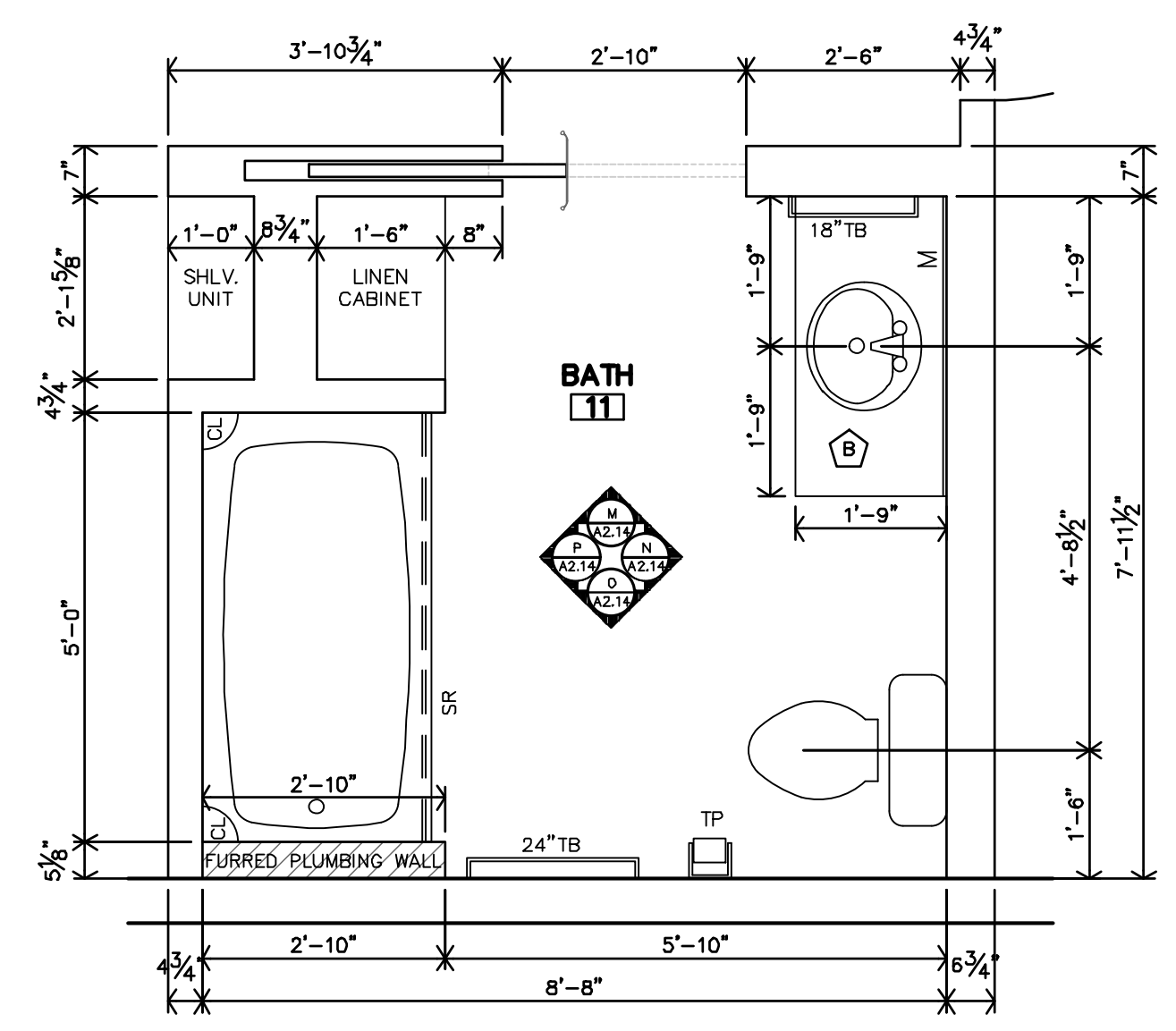

C1 UNIT 3C ADAPTABLE BATH #11 ENLARGED PLAN
1/2"=1'-0"

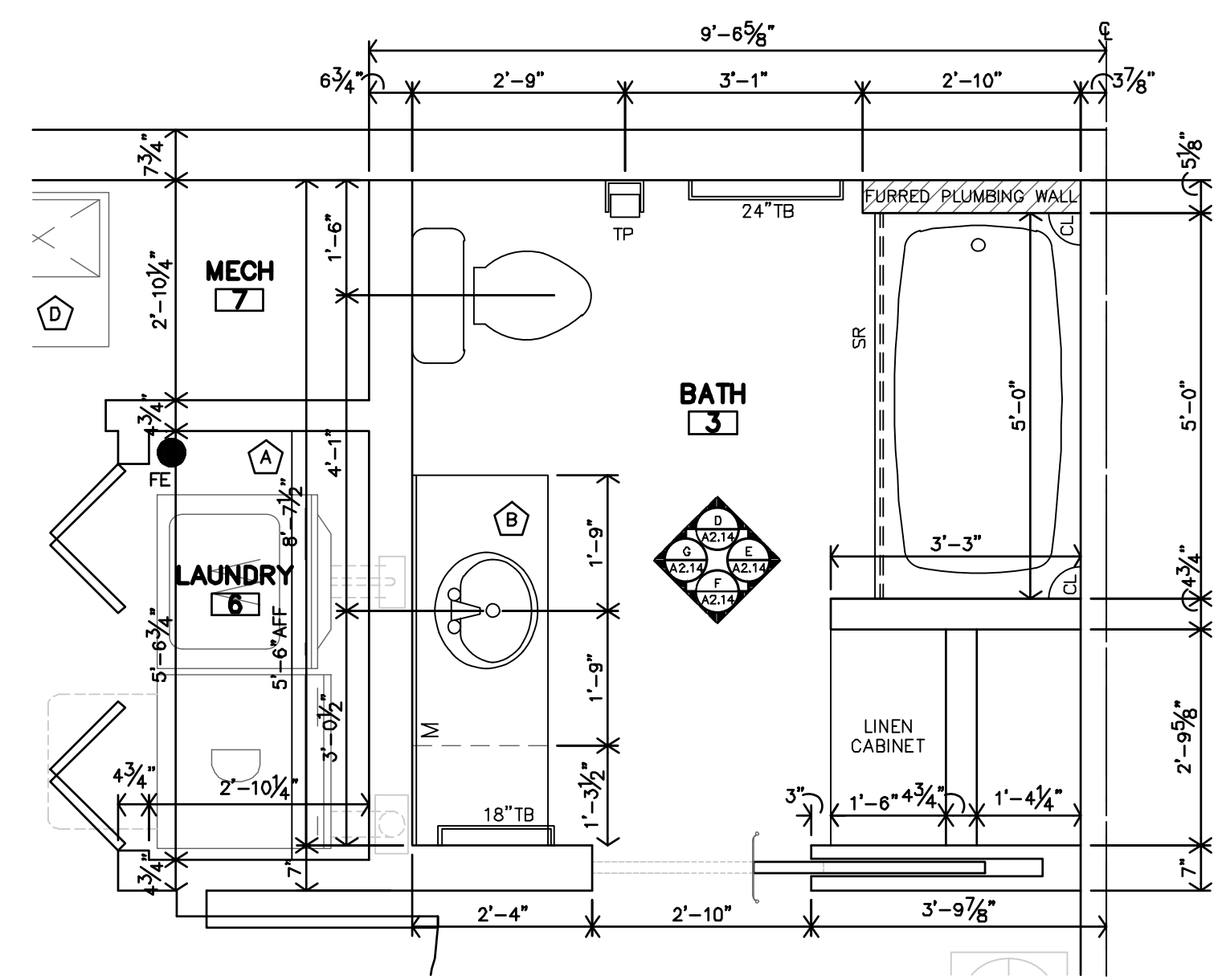

A UNIT 3B ADAPTABLE BATH #4 ENLARGED PLAN
1/2"=1'-0"

ADAPTABLE BATH NOTES	
1. REF. APARTMENT GENERAL & ADAPTABLE UNIT NOTES ON SHEET A2.7 FOR ADDITIONAL DIRECTION.	
2. ALL DIMENSIONS ARE TO FACE OF GYP. BD. UNLESS NOTED OTHERWISE.	
3. CONTRACTOR TO INSTALL 2x8 BLOCKING IN WALLS FOR ALL WALL MOUNTED/SUPPORTED COUNTERTOPS & BRACES, SHOWER UNIT, SLIDE BAR, TOWEL BARS, FUTURE GRABS BARS & FUTURE SHOWER SEAT, ETC. AS REQ'D. (REF. A2.7)	
4. SHOWER SEAT TO BE INSTALLED PER TENANT REQUEST IN ADAPTABLE UNITS.	
5. LOCATION OF WASHER & DRYER IS CRITICAL. WASHER IS TO BE LEFT OF DRYER. ALWAYS. THIS NEEDS TO BE COORDINATED ON SITE. ADAPTABLE & STANDARDS UNITS DESIGNED AROUND 27"x27" WASHER & DRYER.	
6. F.O.S. = FACE OF STUD	

LEGEND	KEYNOTES:
M MIRROR	A PLASTIC COATED WIRE CLOTHES SHELF & ROD (HEIGHT AS CALLED OUT ON PLAN)
TP TOILET PAPER DISPENSER	B FLOORING TO BE CONTINUOUS @ REMOVABLE CABINETS
CL CORNER LEDGE	C VERIFY SIZE W/ SHOWER UNIT
SR SHOWER ROD	D WATER HEATER - REF. MECH. DRAWINGS



REVISION:	
DATE:	1-28-2022
JOB:	21-3137
SHEET:	

ACCESSIBLE BATH NOTES	
1. REF APARTMENT GENERAL & ADAPTABLE UNIT NOTES ON SHEET A2.7 FOR ADDITIONAL DIRECTION.	
2. ALL DIMENSIONS ARE TO FACE OF GYP. BD. UNLESS NOTED OTHERWISE	
3. CONTRACTOR TO INSTALL 2x8 BLOCKING IN WALLS FOR ALL WALL MOUNTED/SUPPORTED COUNTERTOPS & BRACES, SHOWER UNIT SLIDE BAR, TOWEL BARS, FUTURE GRABS BARS & FUTURE SHOWER SEAT, ETC. AS REQ'D. (REF. A2.7)	
4. LOCATION OF WASHER & DRYER IS CRITICAL. WASHER IS TO BE LEFT OF DRYER, ALWAYS. THIS NEEDS TO BE COORDINATED ON SITE. ADAPTABLE & STANDARDS UNITS DESIGNED AROUND 27"X27" WASHER & DRYER. ACCESSIBLE UNITS DESIGNED AROUND 27"X33" WASHER & DRYER.	
LEGEND	KEYNOTES:
M MIRROR	(A) PLASTIC COATED WIRE CLOTHES SHELF & ROD (HEIGHT AS CALLED OUT ON PLAN)
TP TOILET PAPER DISPENSER	(B) FLOORING TO BE CONTINUOUS @ SINK CABINETS & KITCHEN WORKSPACE
TB TOWEL BAR	(C) VERIFY SIZE w/ SHOWER UNIT
CL CORNER LEDGE	(D) WATER HEATER - REF. MECH. DRAWINGS
SR SHOWER ROD	(E) NO CABINETS ABOVE WASHER & DRYER
SH SHOWER SEAT	
GB GRAB BAR	

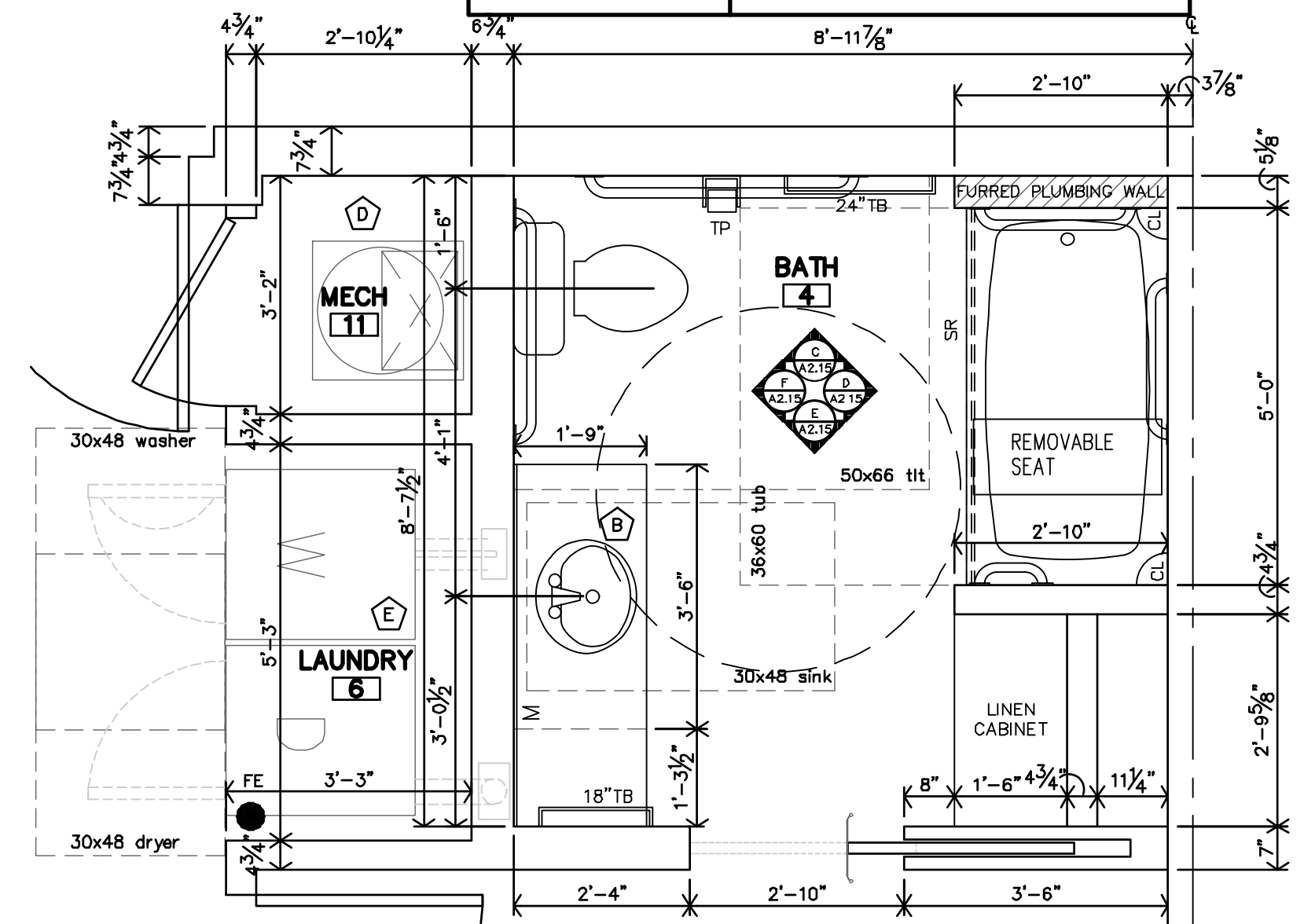

B UNIT 1A ACCESSIBLE BATH #4 ENLARGED PLAN
 1/2"=1'-0"

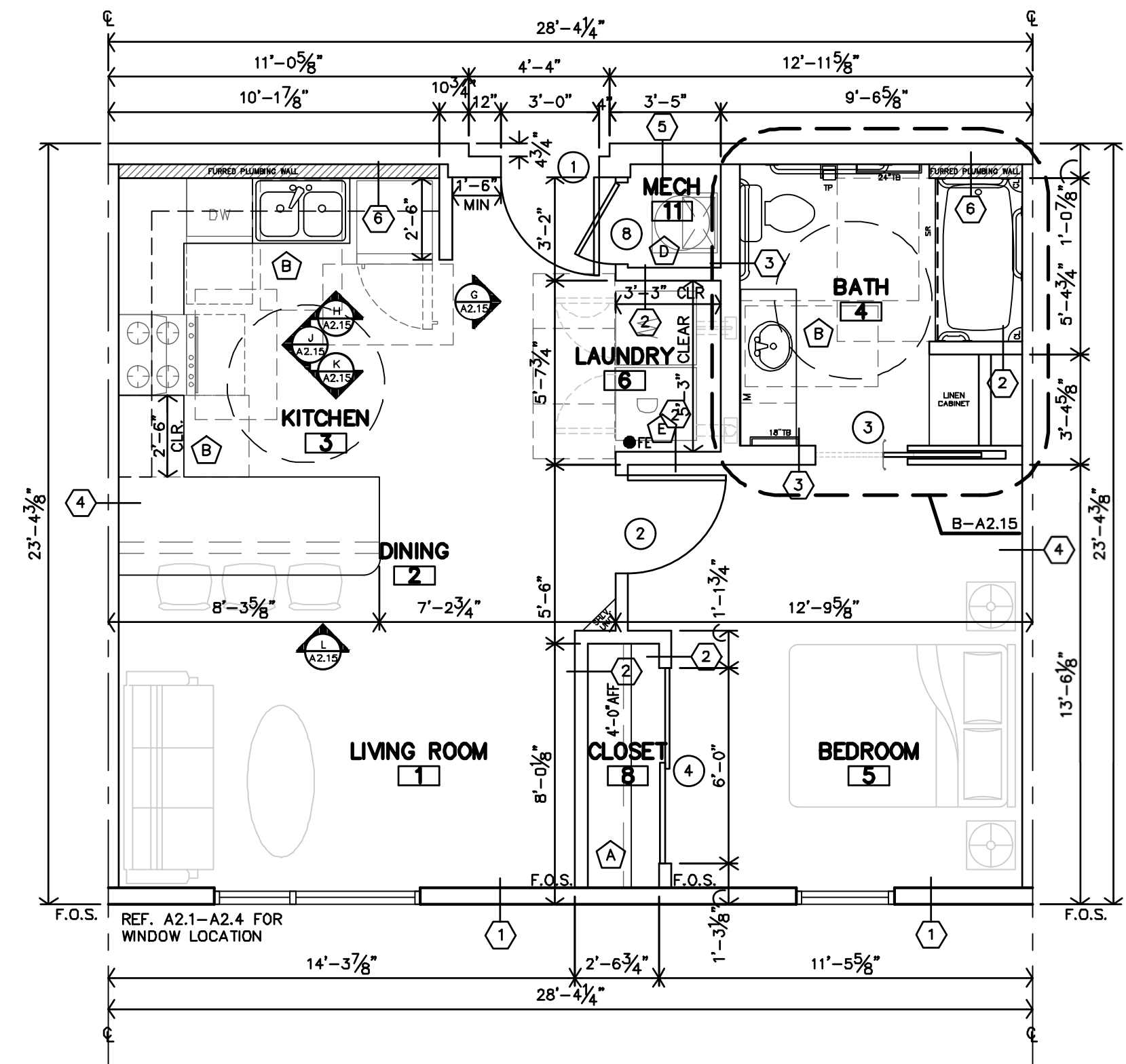

A UNIT 1A ACCESSIBLE 1 BEDROOM - 1 BATH UNIT PLAN
 1/4"=1'-0"

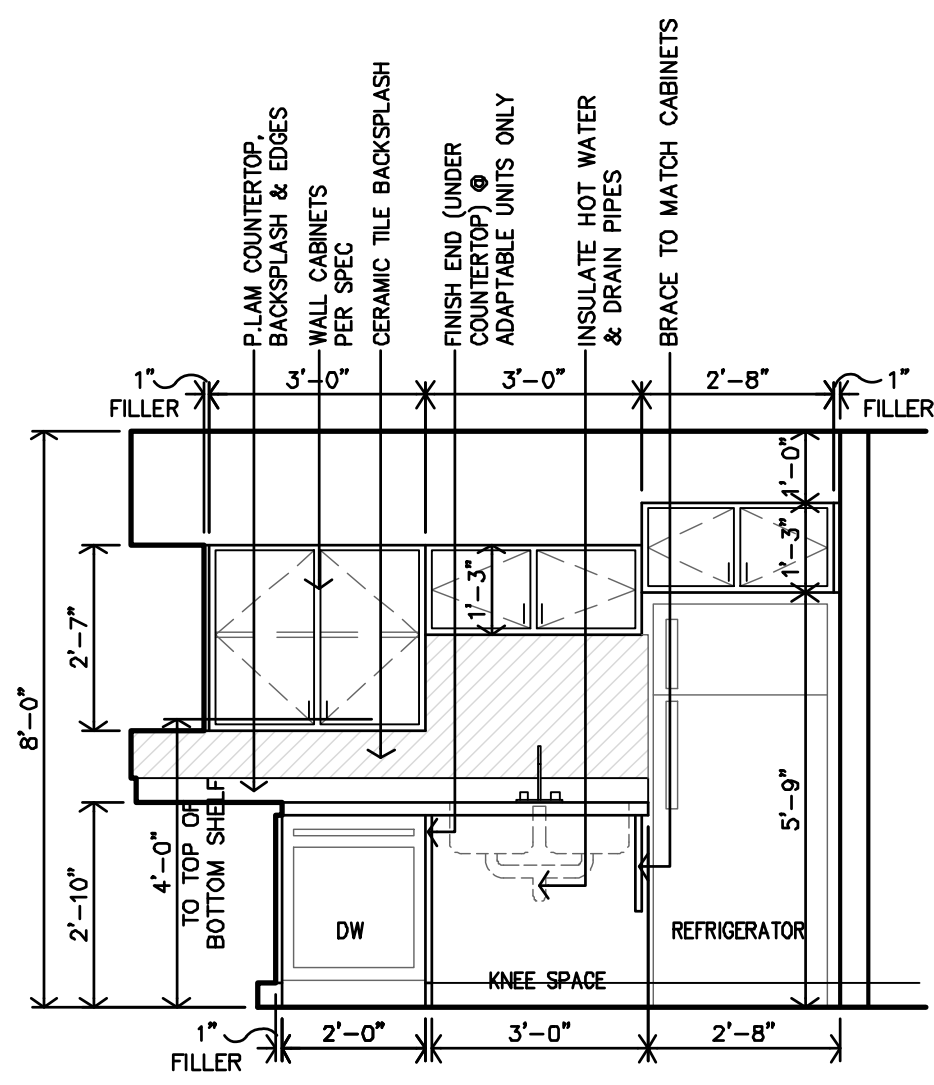

H UNIT 1A KITCHEN #3 INTERIOR ELEV.
 3/8"=1'-0"

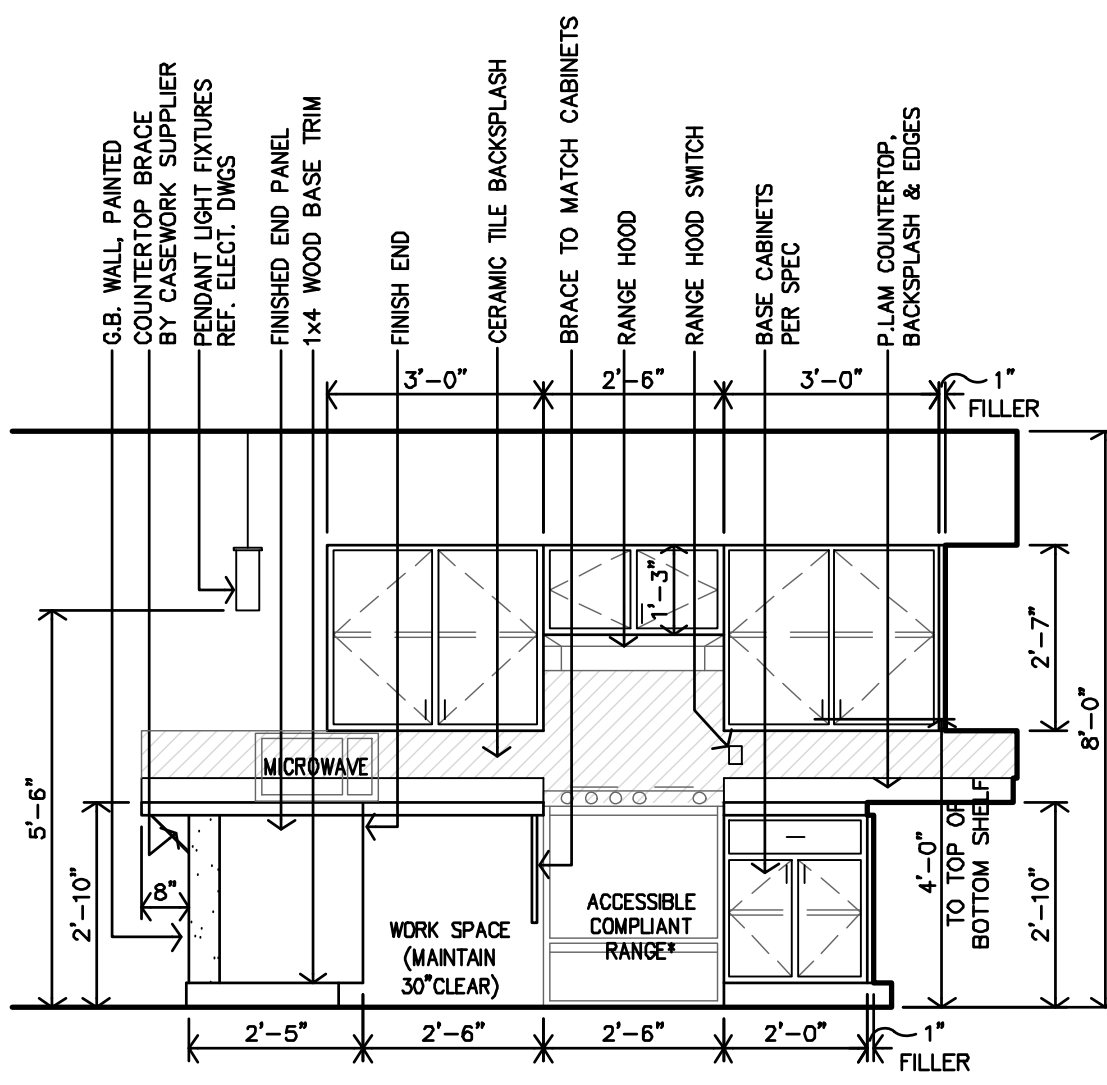

J UNIT 1A KITCHEN #3 INTERIOR ELEV.
 3/8"=1'-0"

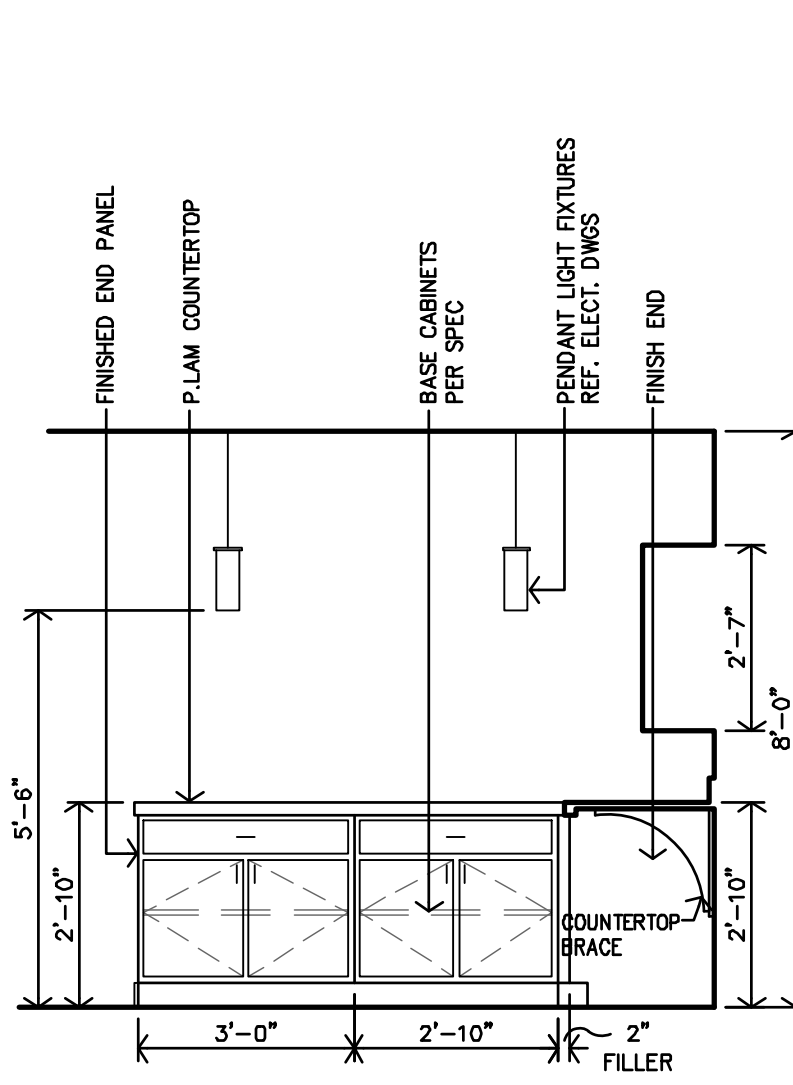

K UNIT 1A KITCHEN #3 INTERIOR ELEV.
 3/8"=1'-0"

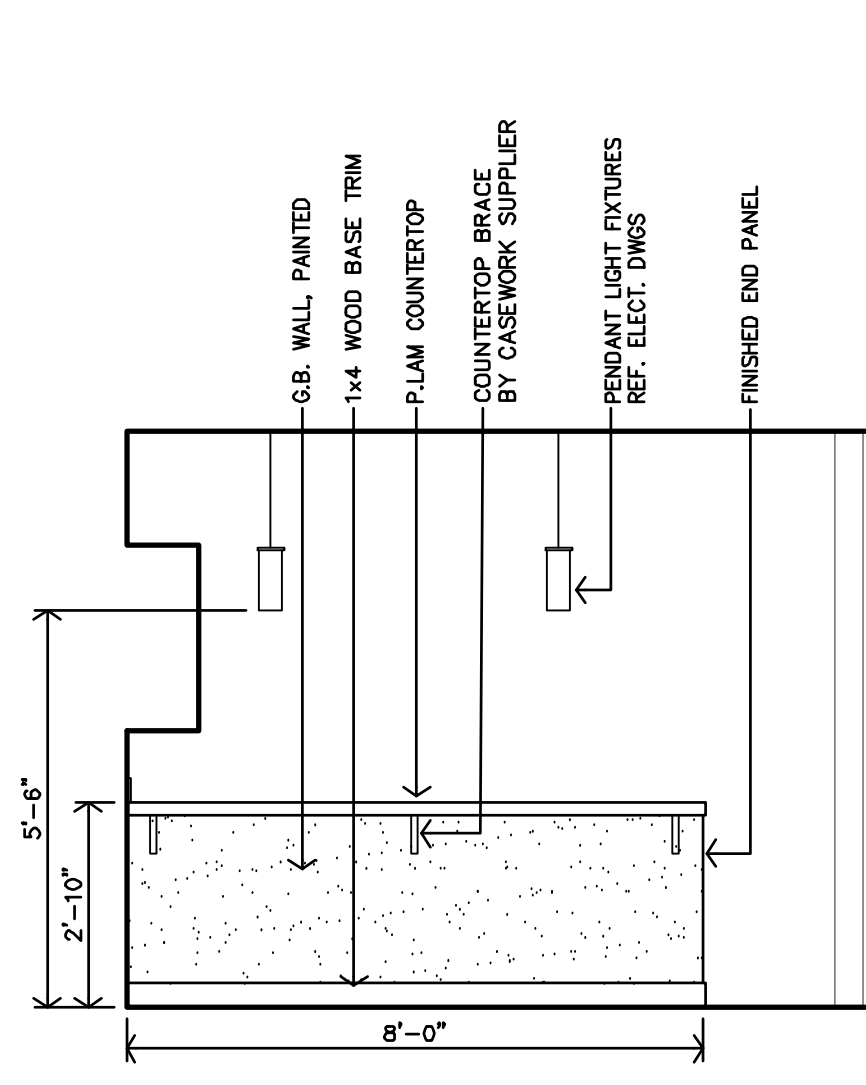

L UNIT 1A KITCHEN #3 INTERIOR ELEV.
 3/8"=1'-0"

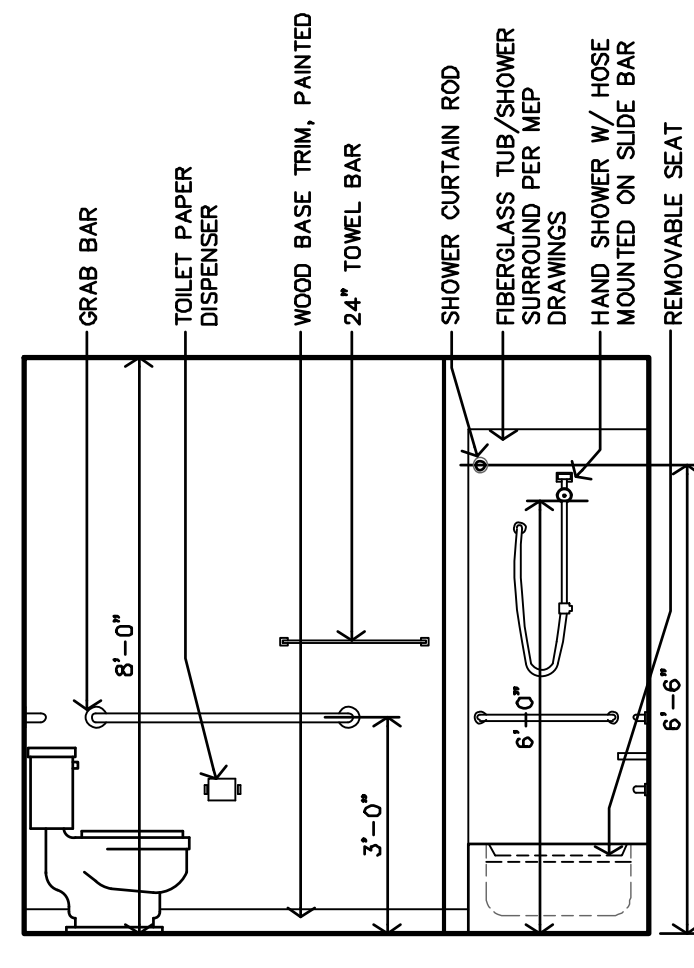

C UNIT 1A BATH #4 INTERIOR ELEV.
 3/8"=1'-0"

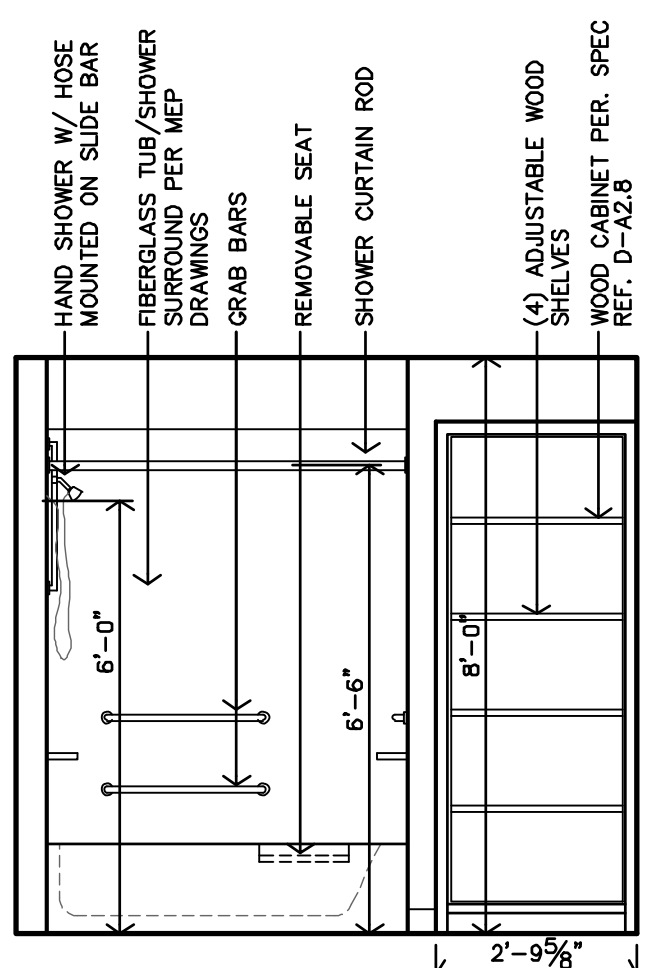

D UNIT 1A BATH #4 INTERIOR ELEV.
 3/8"=1'-0"

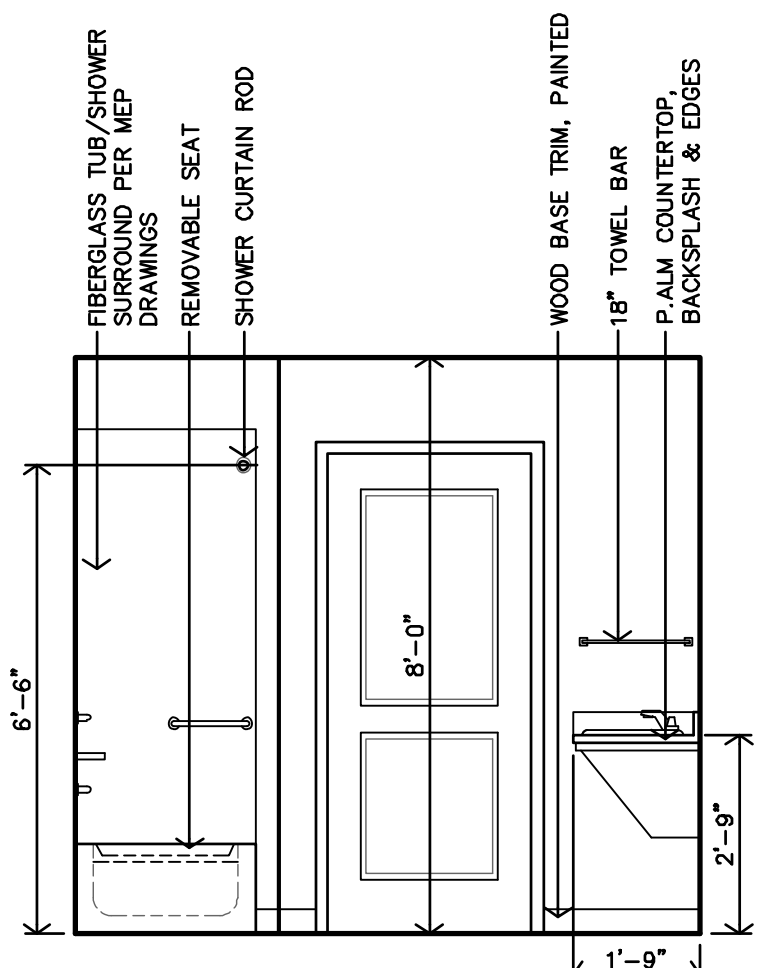

E UNIT 1A BATH #4 INTERIOR ELEV.
 3/8"=1'-0"

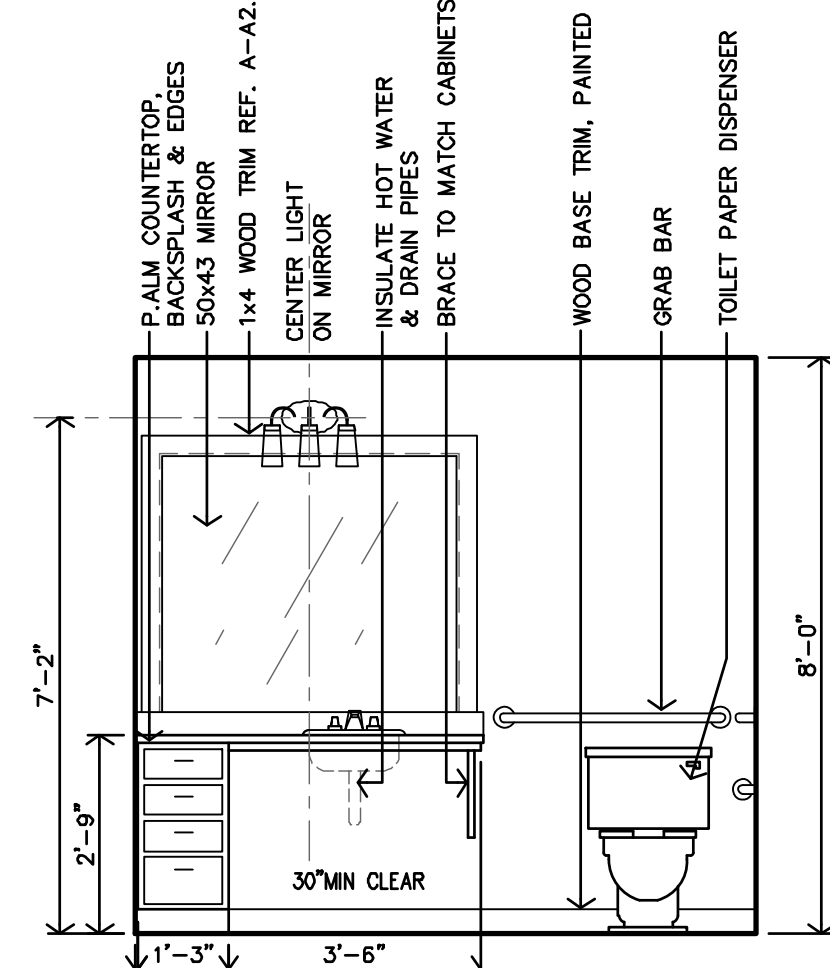

F UNIT 1A BATH #4 INTERIOR ELEV.
 3/8"=1'-0"

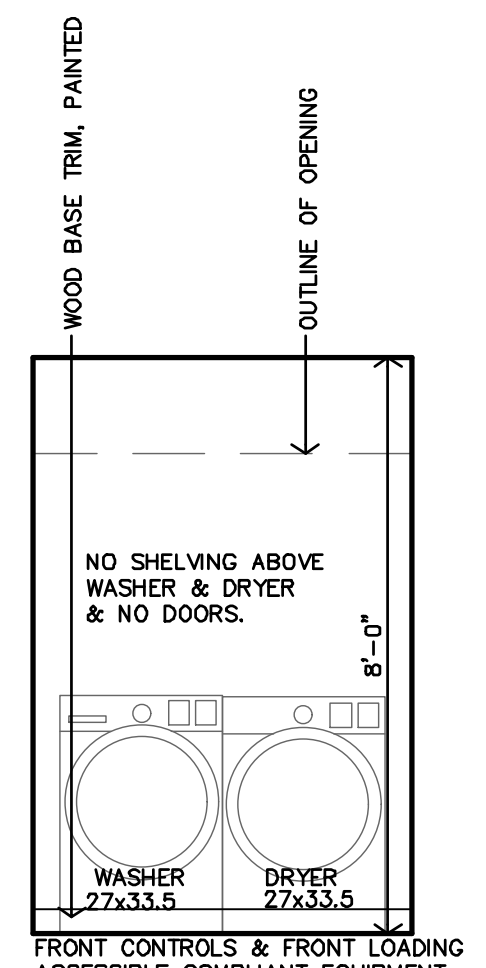

G UNIT 1A LAUNDRY #6 INTERIOR ELEV.
 3/8"=1'-0"

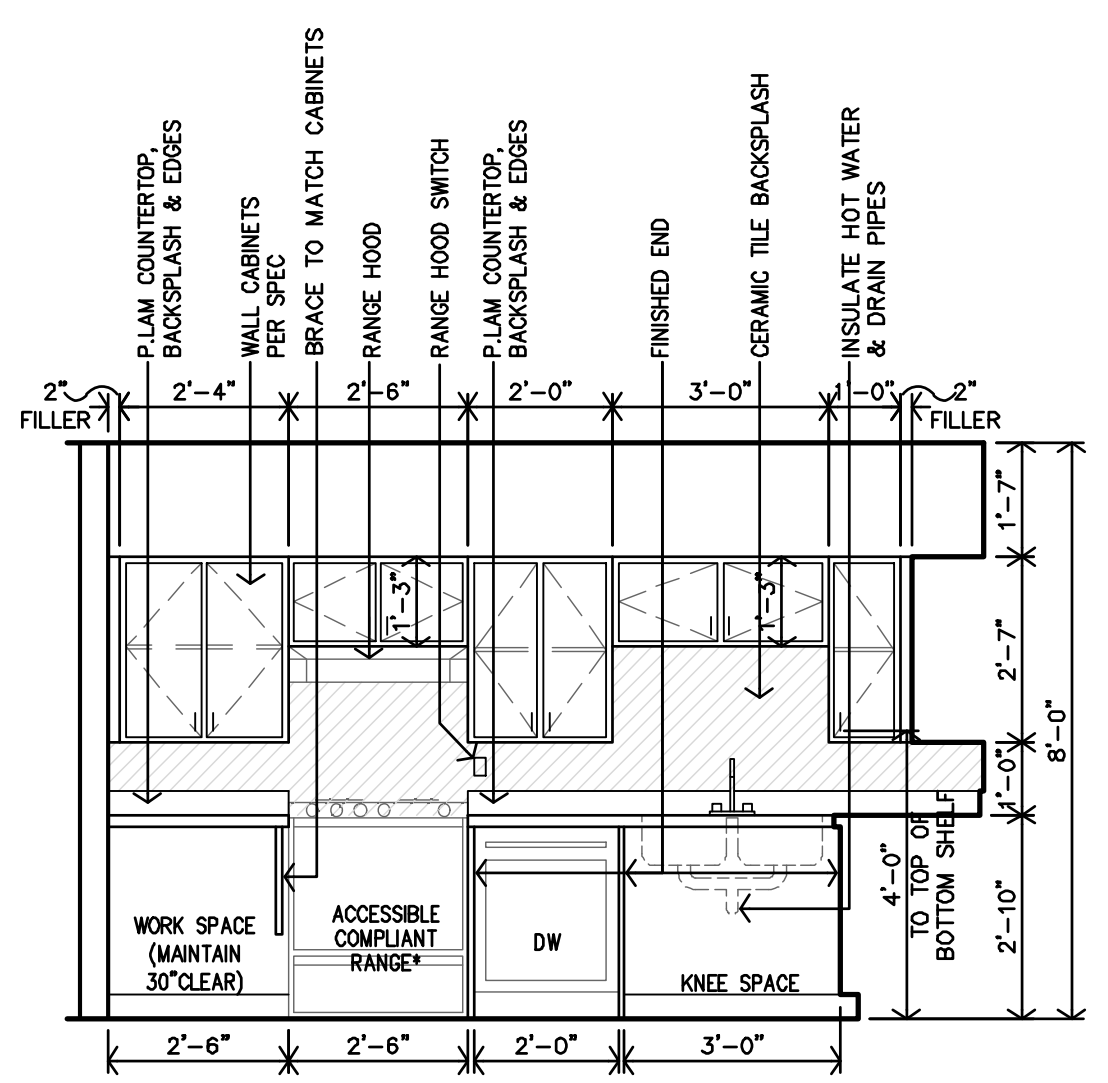

M UNIT 2A KITCHEN #3 INTERIOR ELEV.
 3/8"=1'-0"

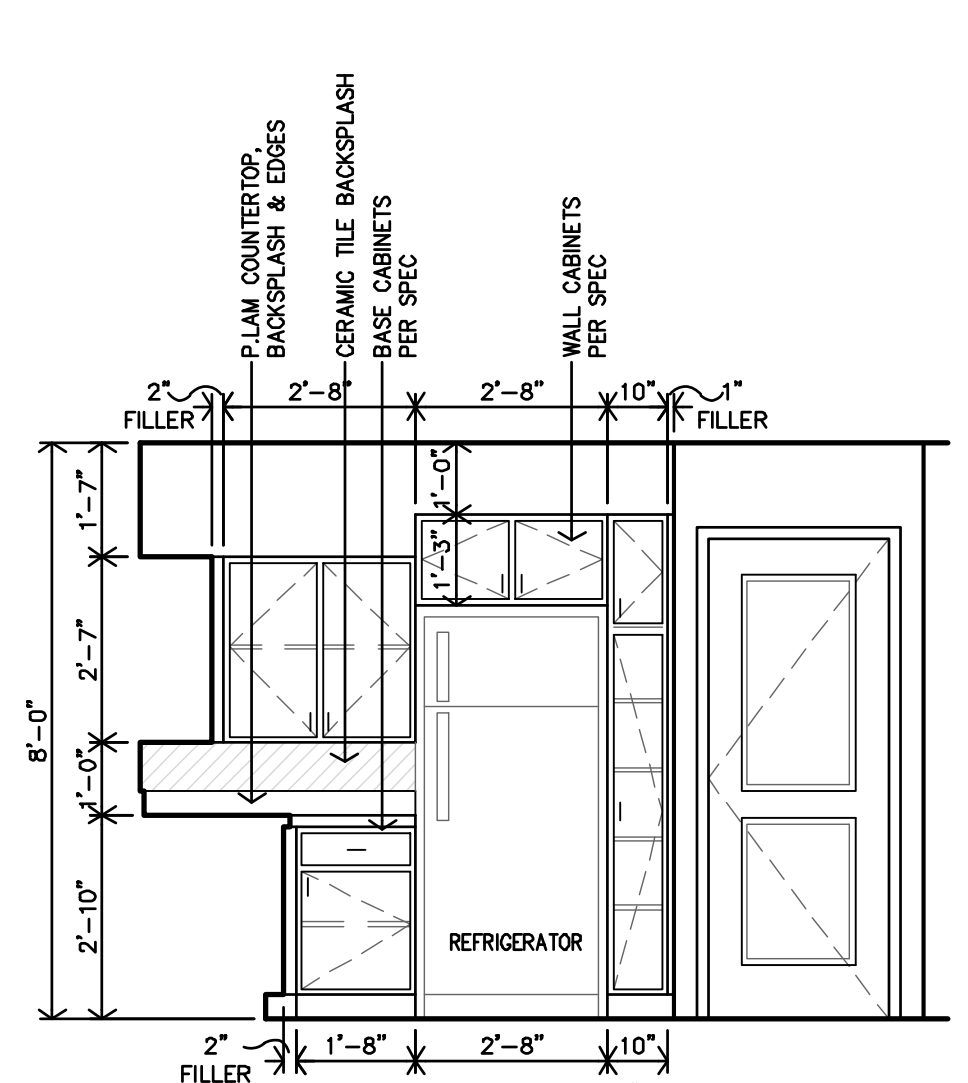

N UNIT 2A KITCHEN #3 INTERIOR ELEV.
 3/8"=1'-0"

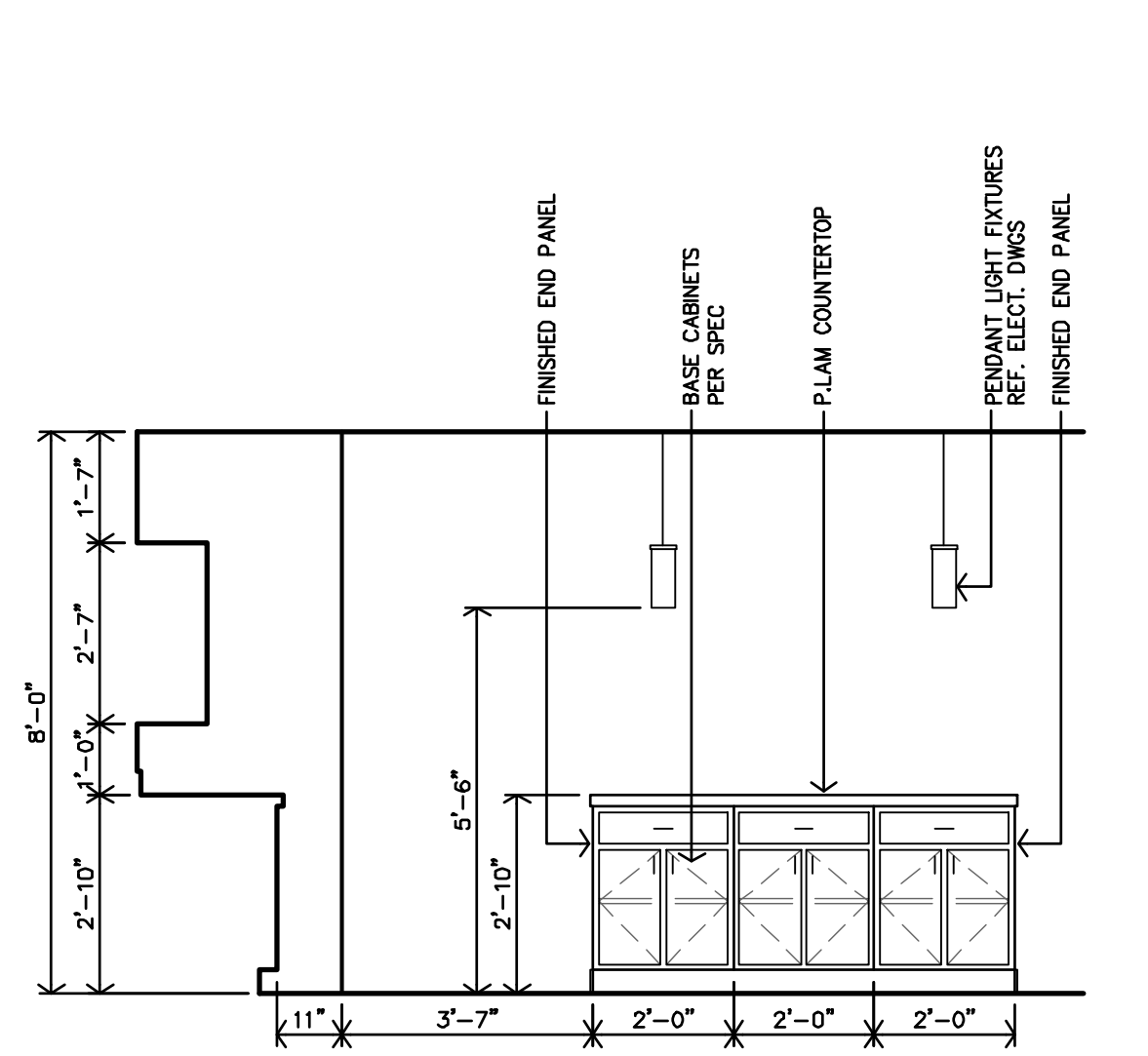

O UNIT 2A KITCHEN #3 INTERIOR ELEV.
 3/8"=1'-0"

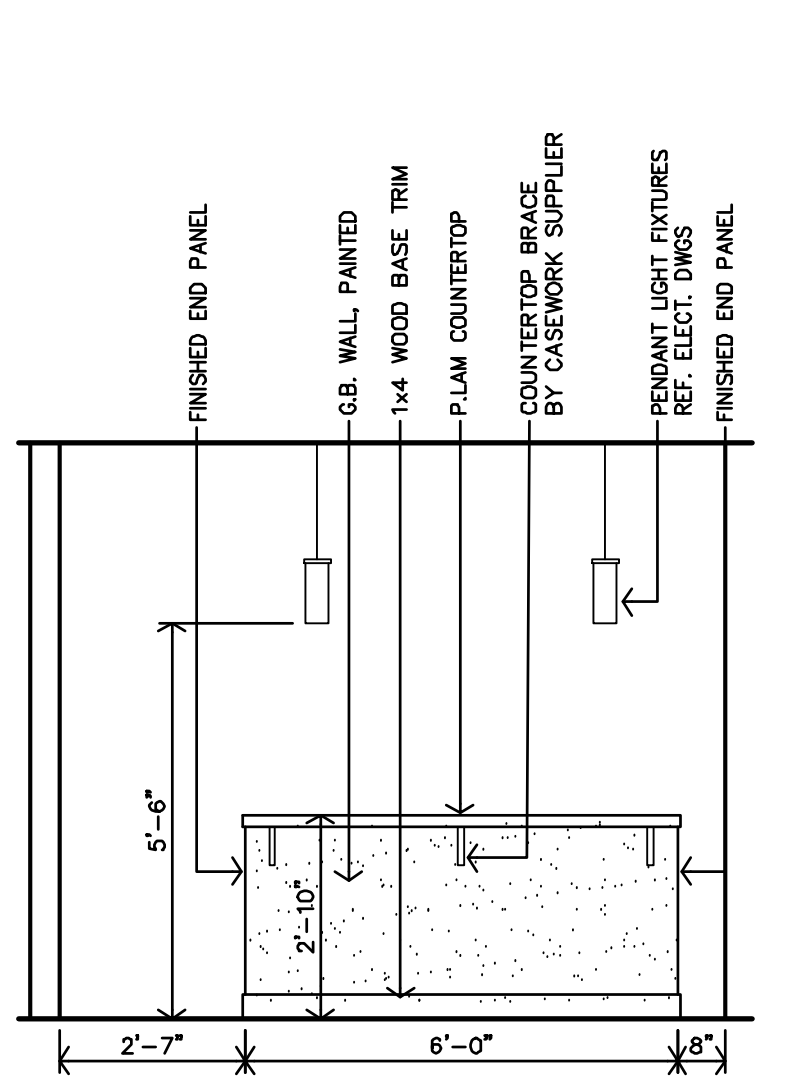

P UNIT 2A KITCHEN #3 INTERIOR ELEV.
 3/8"=1'-0"

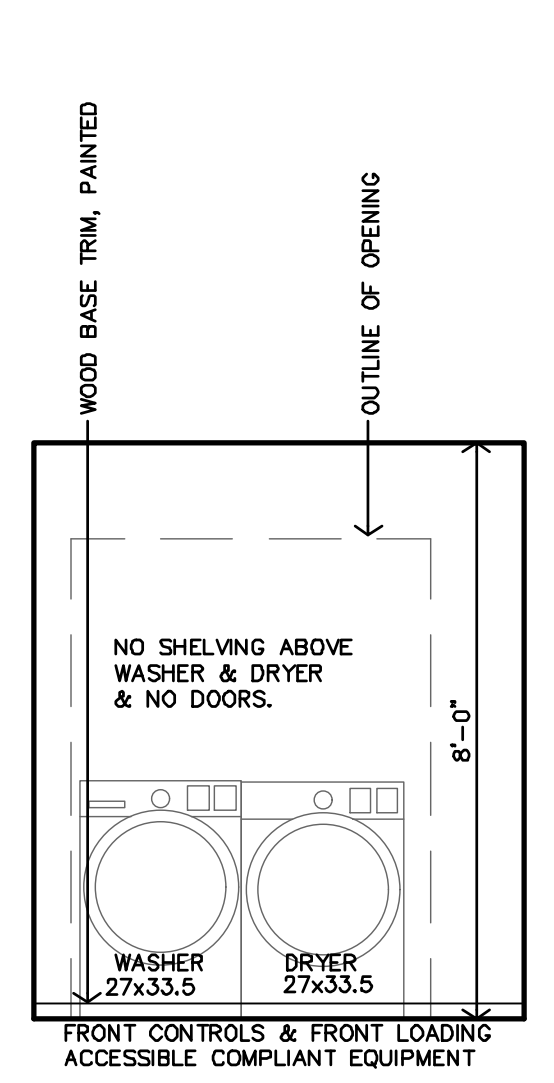

Q UNIT 2A KITCHEN #3 INTERIOR ELEV.
 3/8"=1'-0"

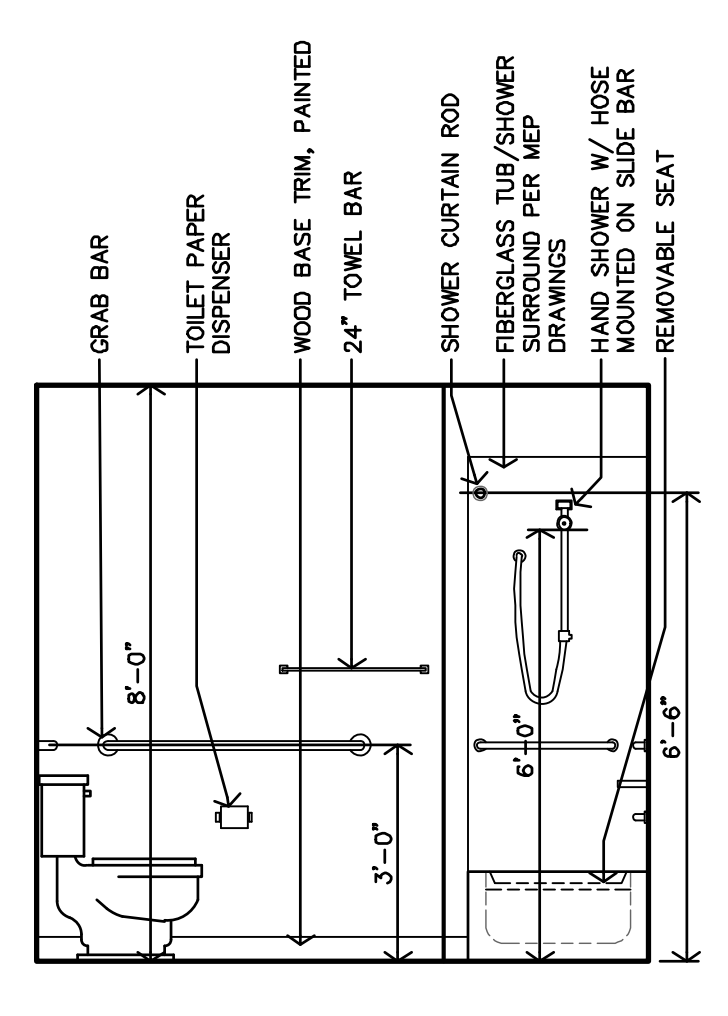

D UNIT 2A BATH #4 INTERIOR ELEV.
 3/8"=1'-0"

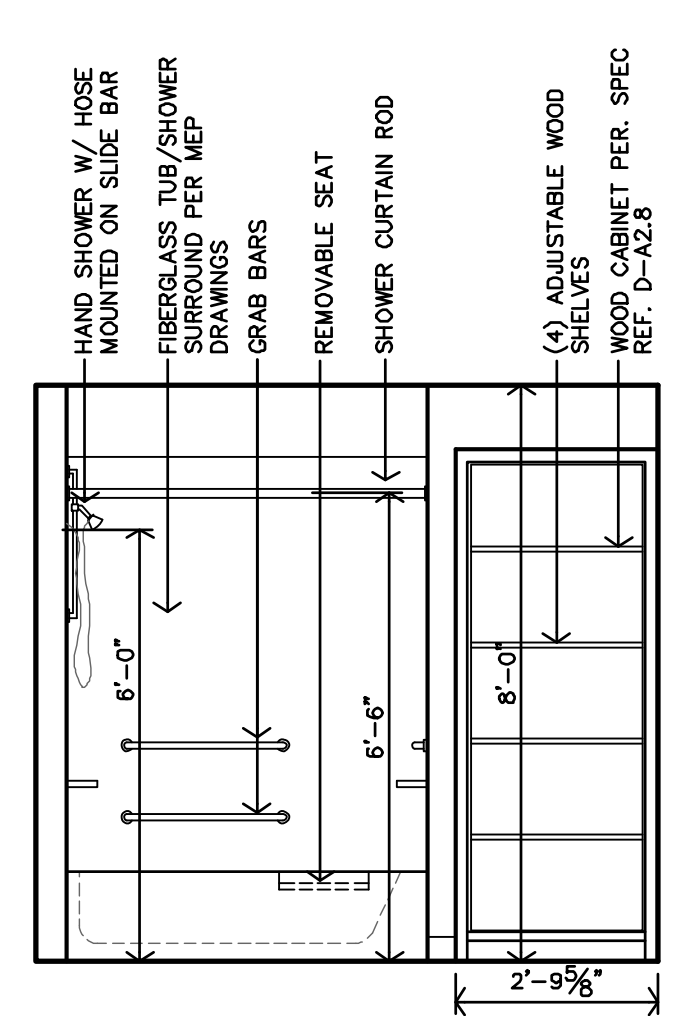

E UNIT 2A BATH #4 INTERIOR ELEV.
 3/8"=1'-0"

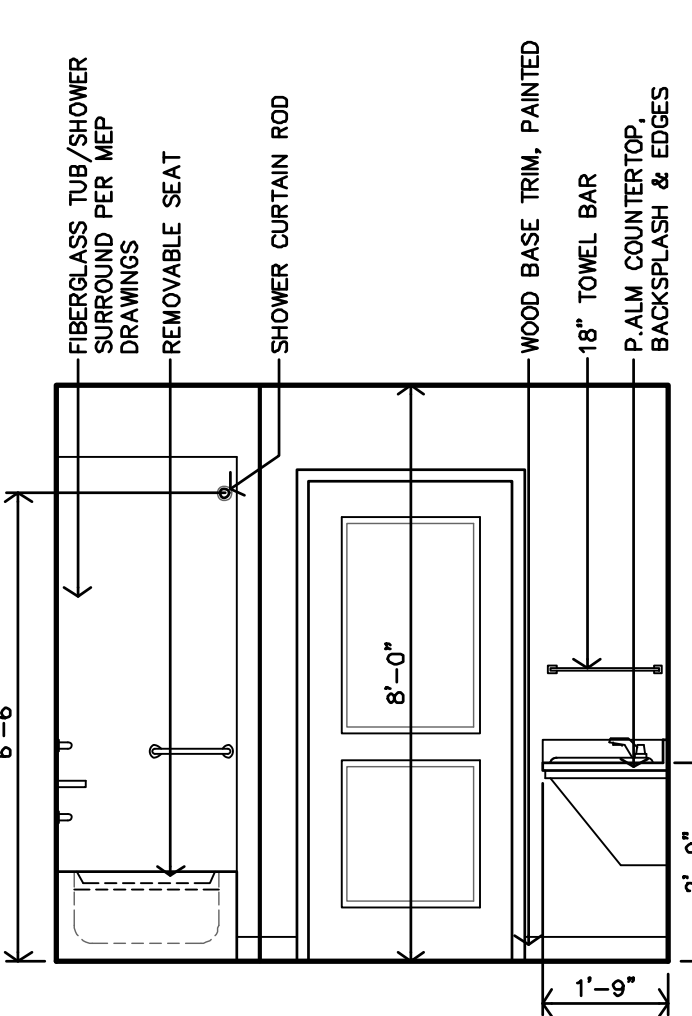

F UNIT 2A BATH #4 INTERIOR ELEV.
 3/8"=1'-0"

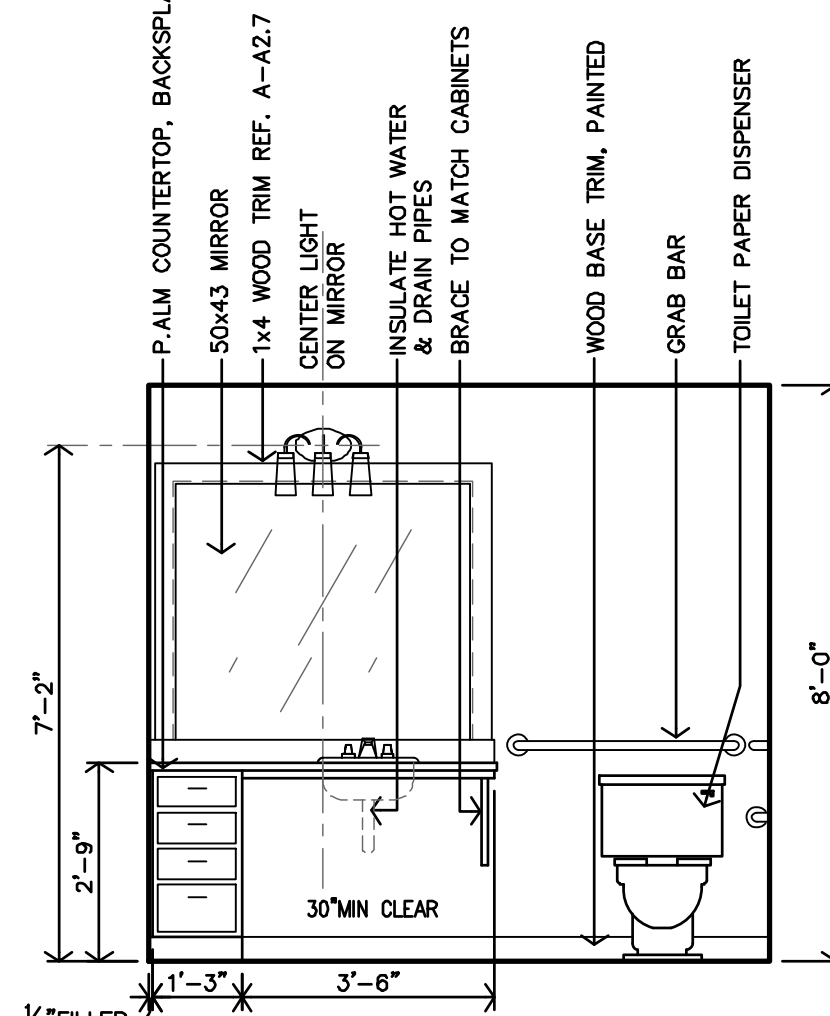

G UNIT 2A BATH #4 INTERIOR ELEV.
 3/8"=1'-0"

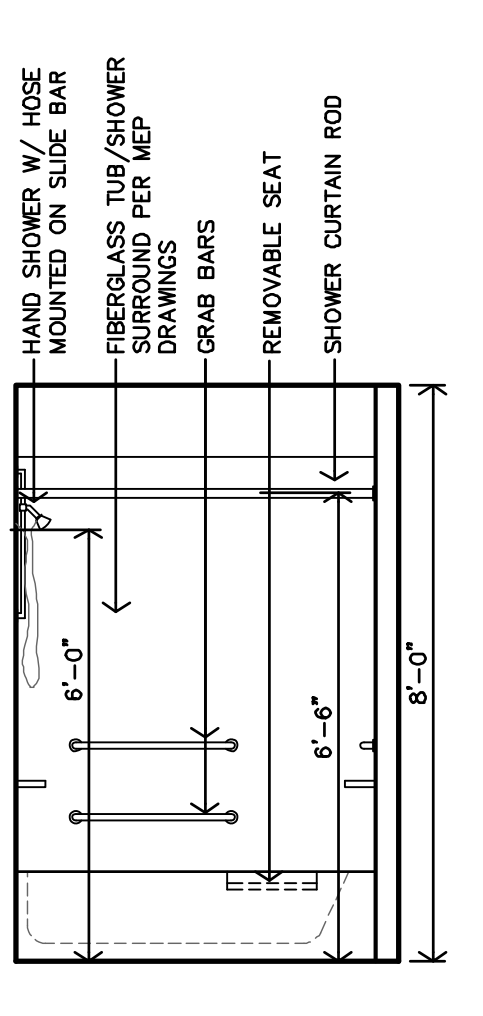

H UNIT 2A BATH #11 INTERIOR ELEV.
 3/8"=1'-0"

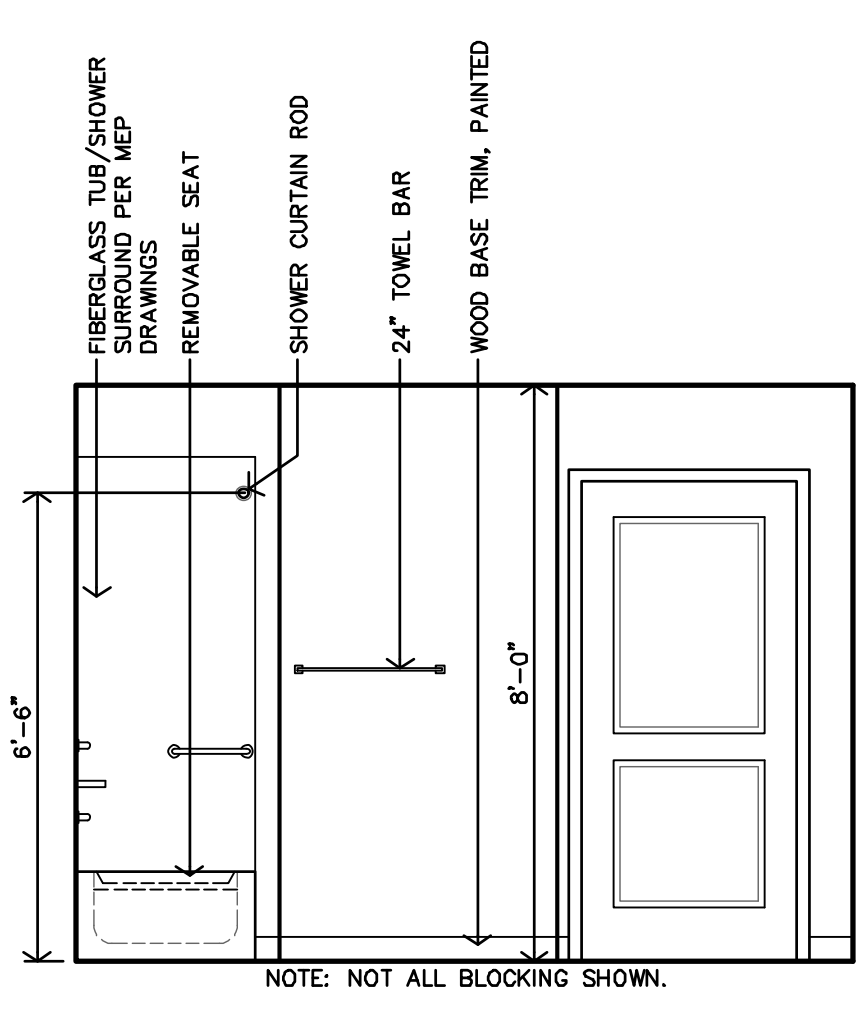

J UNIT 2A BATH #11 INTERIOR ELEV.
 3/8"=1'-0"

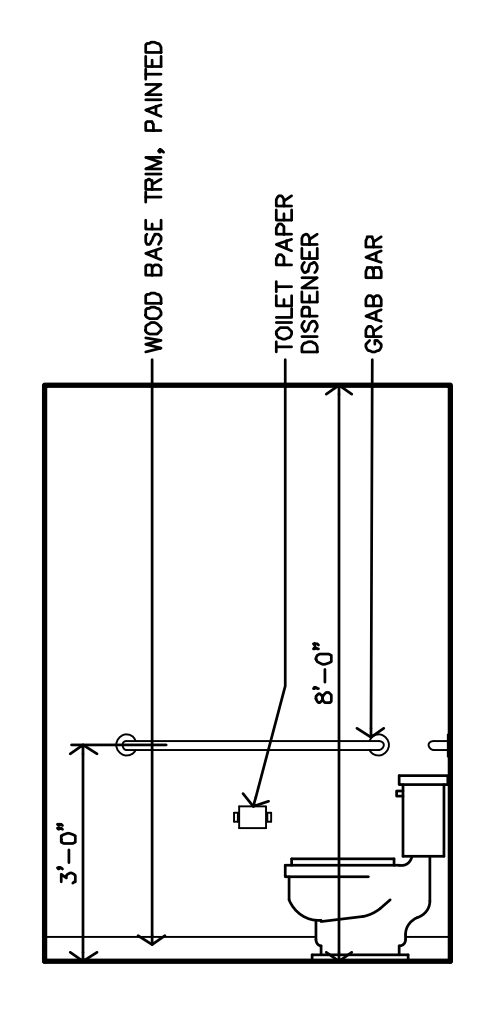

K UNIT 2A BATH #11 INTERIOR ELEV.
 3/8"=1'-0"

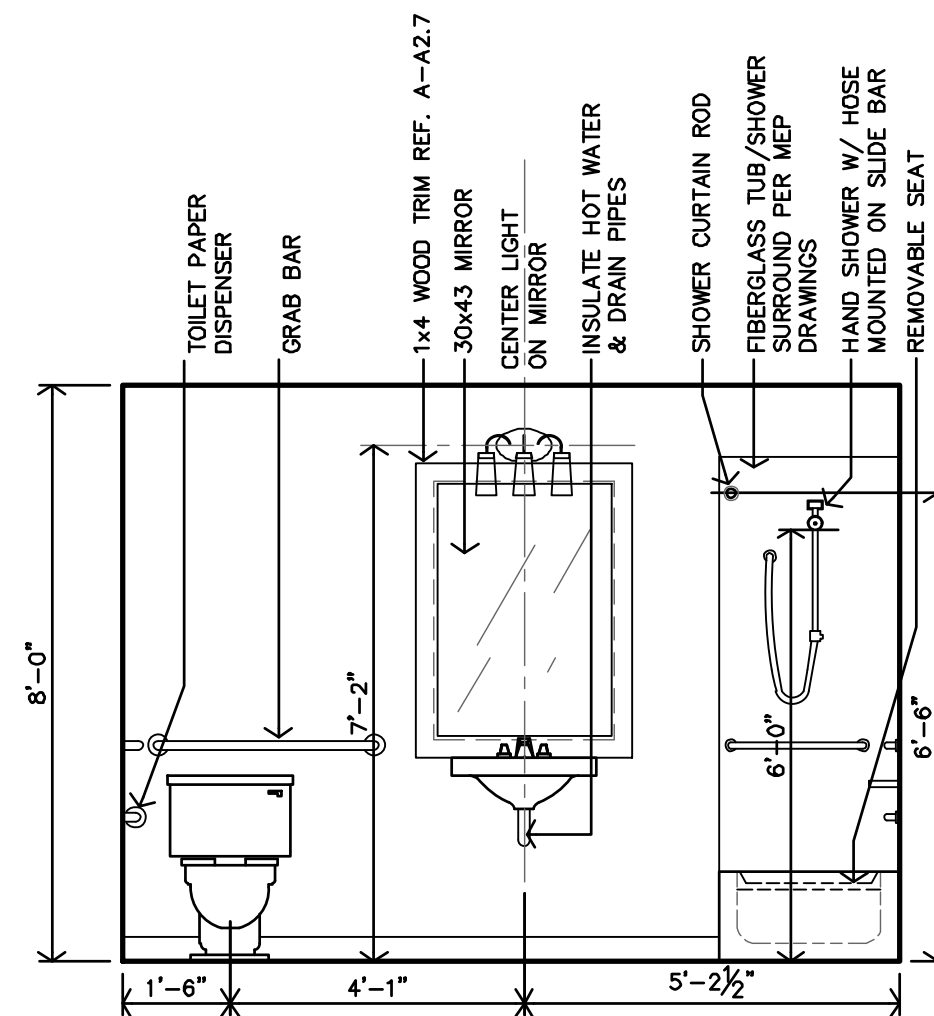

L UNIT 2A BATH #11 INTERIOR ELEV.
 3/8"=1'-0"

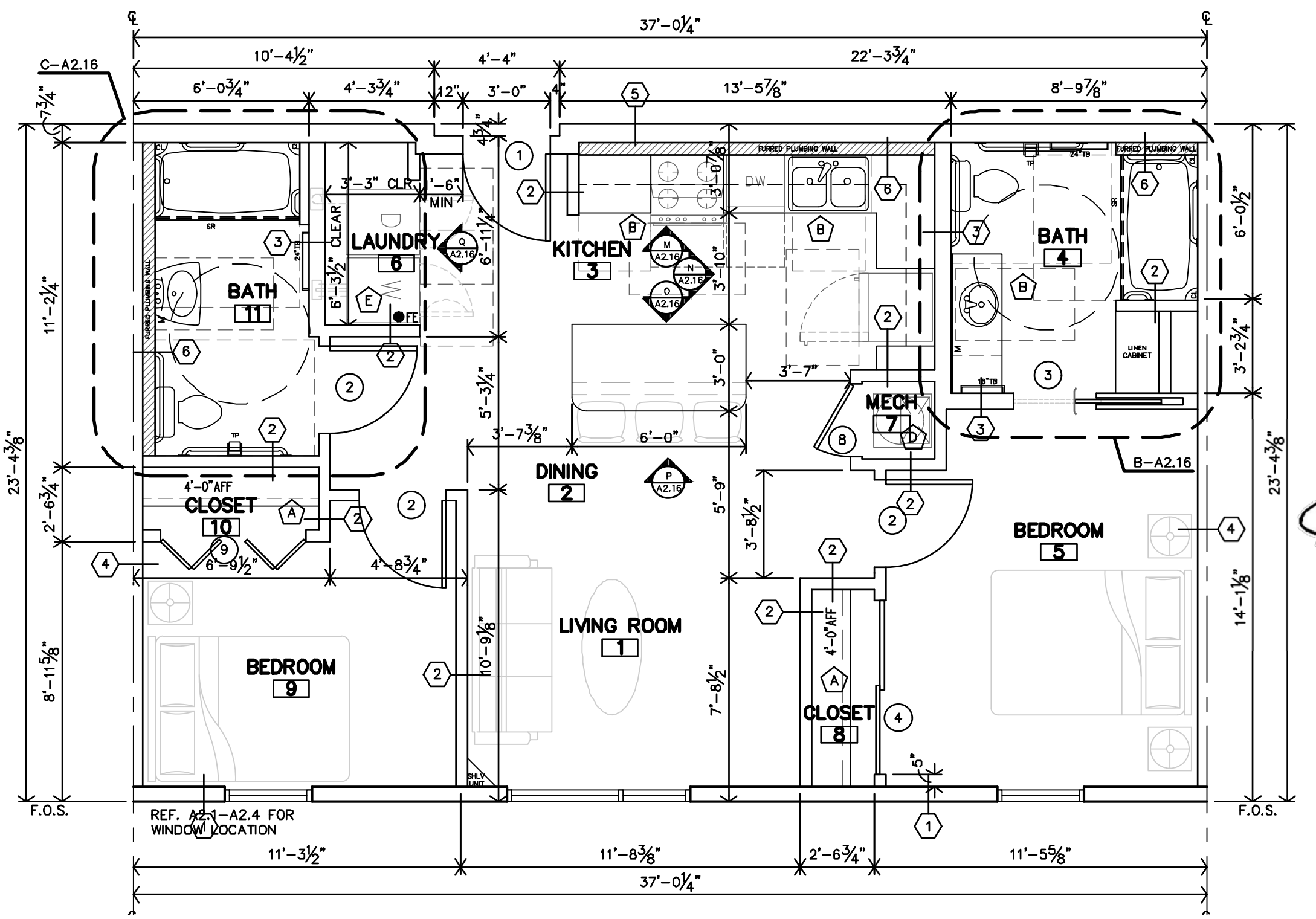

A UNIT 2A ACCESSIBLE 2 BEDROOM - 2 BATH UNIT PLAN
 1/4"=1'-0"

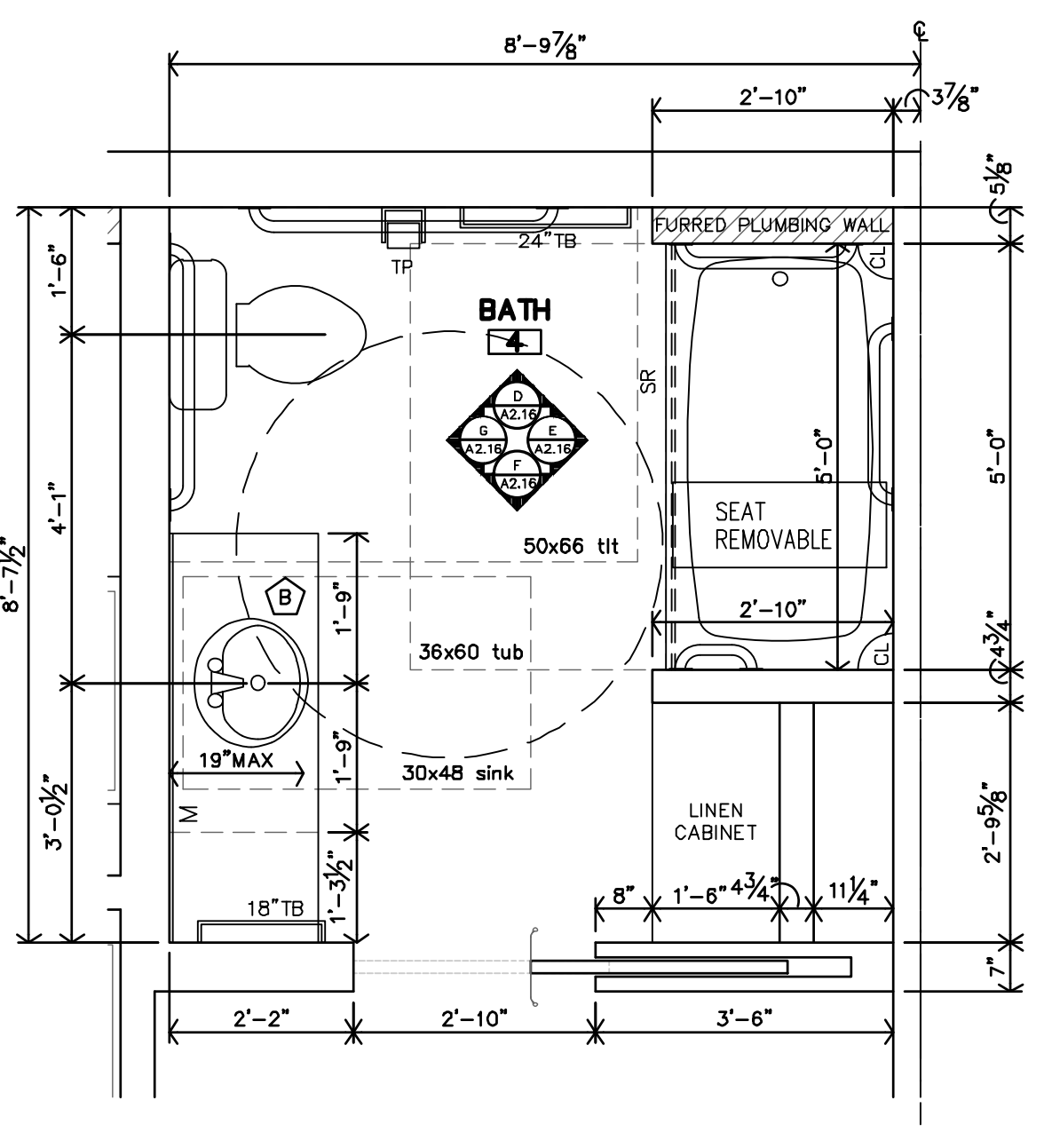

B UNIT 2A ACCESSIBLE BATH #4 ENLARGED PLAN
 1/2"=1'-0"

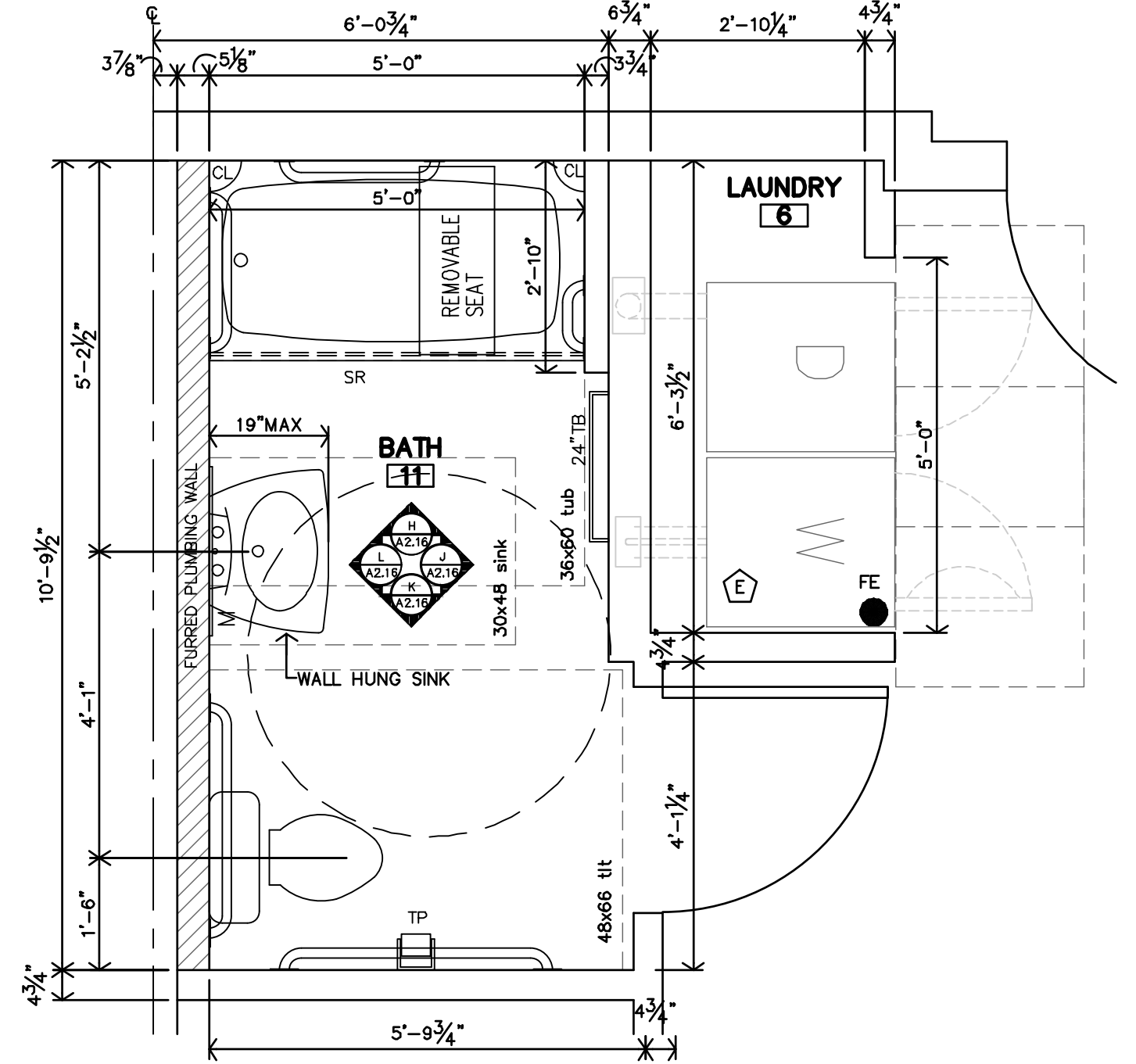

C UNIT 2A ACCESSIBLE BATH #11 ENLARGED PLAN
 1/2"=1'-0"

ACCESSIBLE BATH NOTES

- REF APARTMENT GENERAL & ADAPTABLE UNIT NOTES ON SHEET A2.7 FOR ADDITIONAL DIRECTION.
- ALL DIMENSIONS ARE TO FACE OF CYP. BD. UNLESS NOTED OTHERWISE
- CONTRACTOR TO INSTALL 2x8 BLOCKING IN WALLS FOR ALL WALL MOUNTED/SUPPORTED COUNTERTOPS & BRACES, SHOWER UNIT, SLIDE BAR, TOWEL BARS, FUTURE GRABS BARS & FUTURE SHOWER SEAT, ETC. AS REQ'D. (REF. A2.7)
- LOCATION OF WASHER & DRYER IS CRITICAL. WASHER IS TO BE LEFT OF DRYER. ALWAYS. THIS NEEDS TO BE COORDINATED ON SITE. ADAPTABLE & STANDARDS UNITS DESIGNED AROUND 27"x33" WASHER & DRYER. ACCESSIBLE UNITS DESIGNED AROUND 27"x33" WASHER & DRYER.

LEGEND	KEYNOTES:
M MIRROR	(A) PLASTIC COATED WIRE CLOTHES SHELF & ROD (HEIGHT AS CALLED OUT ON PLAN)
TP TOILET PAPER DISPENSER	(B) FLOORING TO BE CONTINUOUS @ SINK CABINETS & KITCHEN WORKSPACE
CL CORNER LEDGE	(C) VERIFY SIZE W/ SHOWER UNIT
SR SHOWER ROD	(D) WATER HEATER - REF. MECH. DRAWINGS
SH SHOWER SEAT	(E) NO CABINETS ABOVE WASHER & DRYER
GB GRAB BAR	

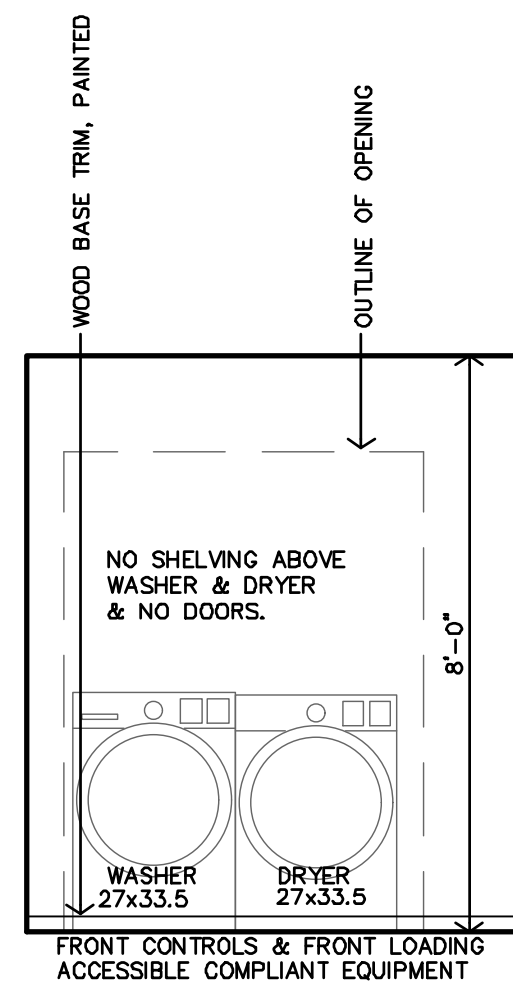

R UNIT 3A LAUNDRY #6 INTERIOR ELEV.
3/8"=1'-0"

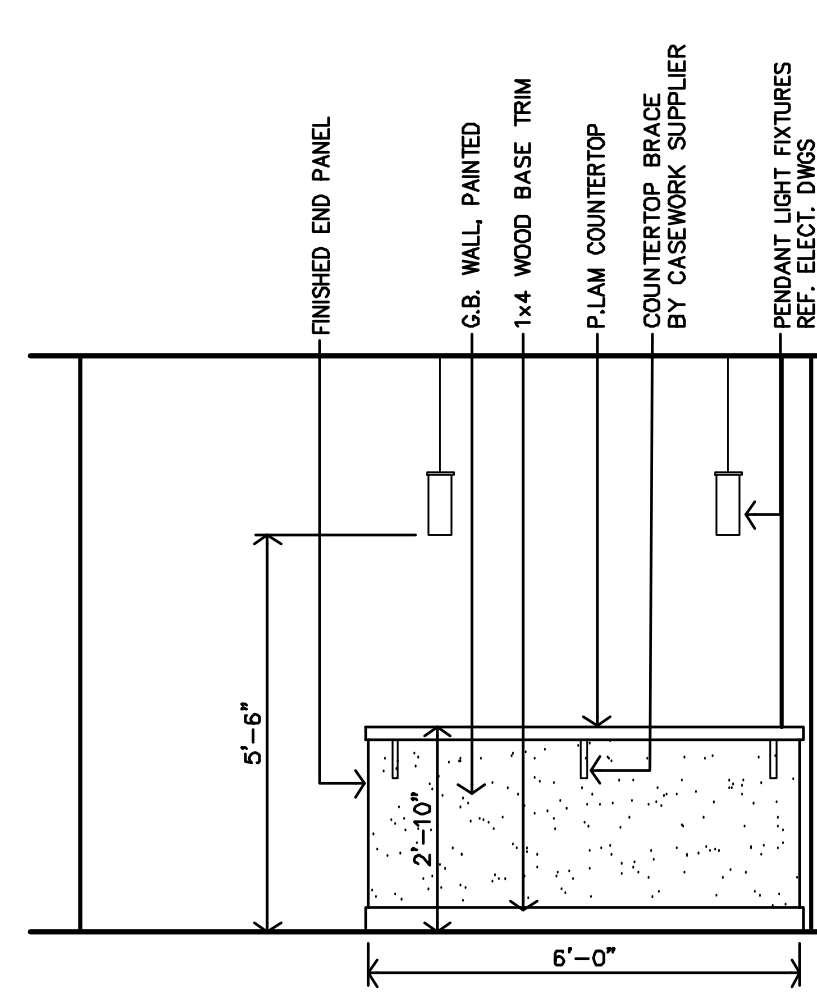

Q UNIT 3A KITCHEN #3 INTERIOR ELEV.
3/8"=1'-0"

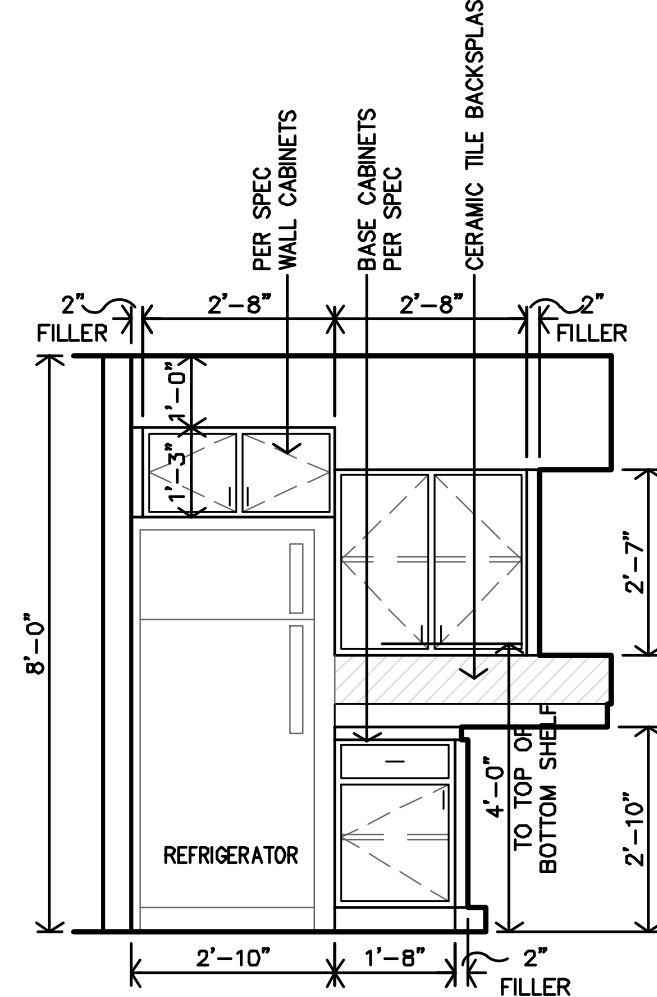

P UNIT 3A KITCHEN #3 INTERIOR ELEV.
3/8"=1'-0"

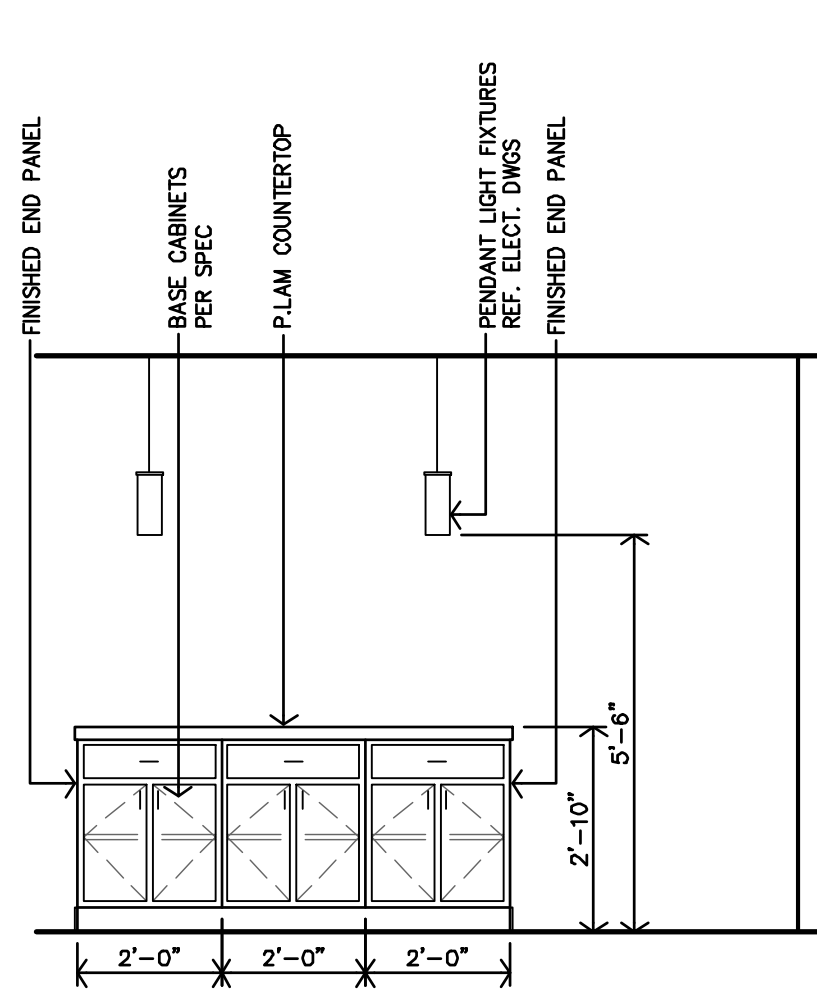

O UNIT 3A KITCHEN #3 INTERIOR ELEV.
3/8"=1'-0"

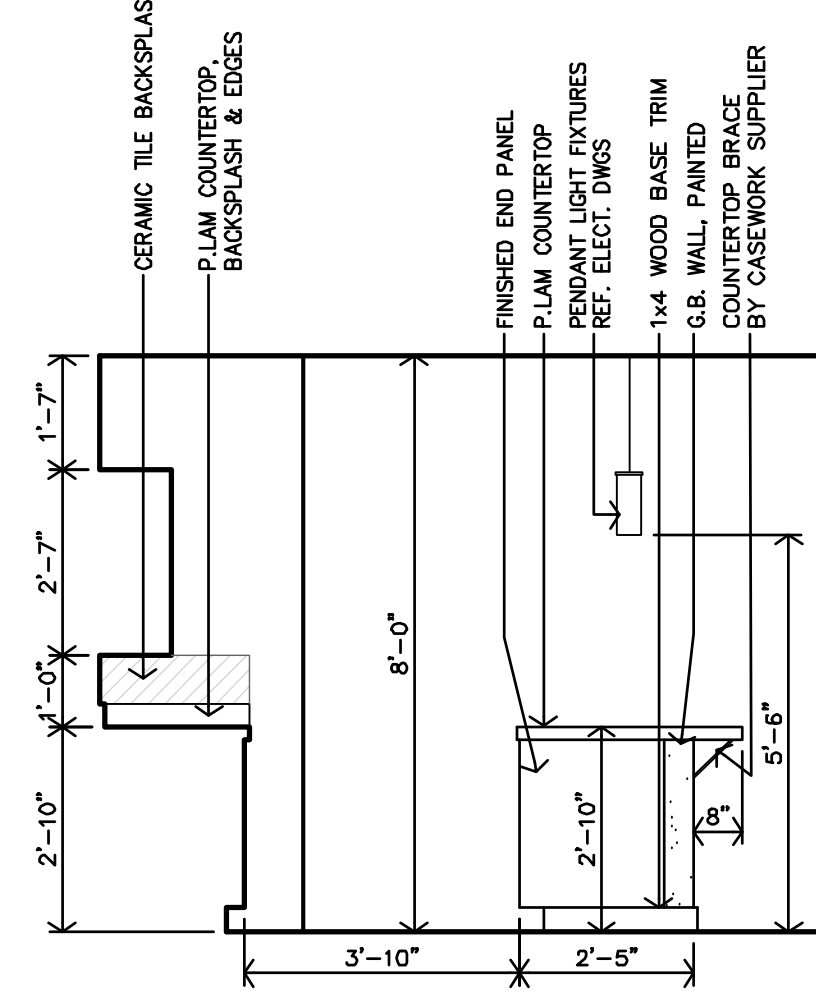

N UNIT 3A KITCHEN #3 INTERIOR ELEV.
3/8"=1'-0"

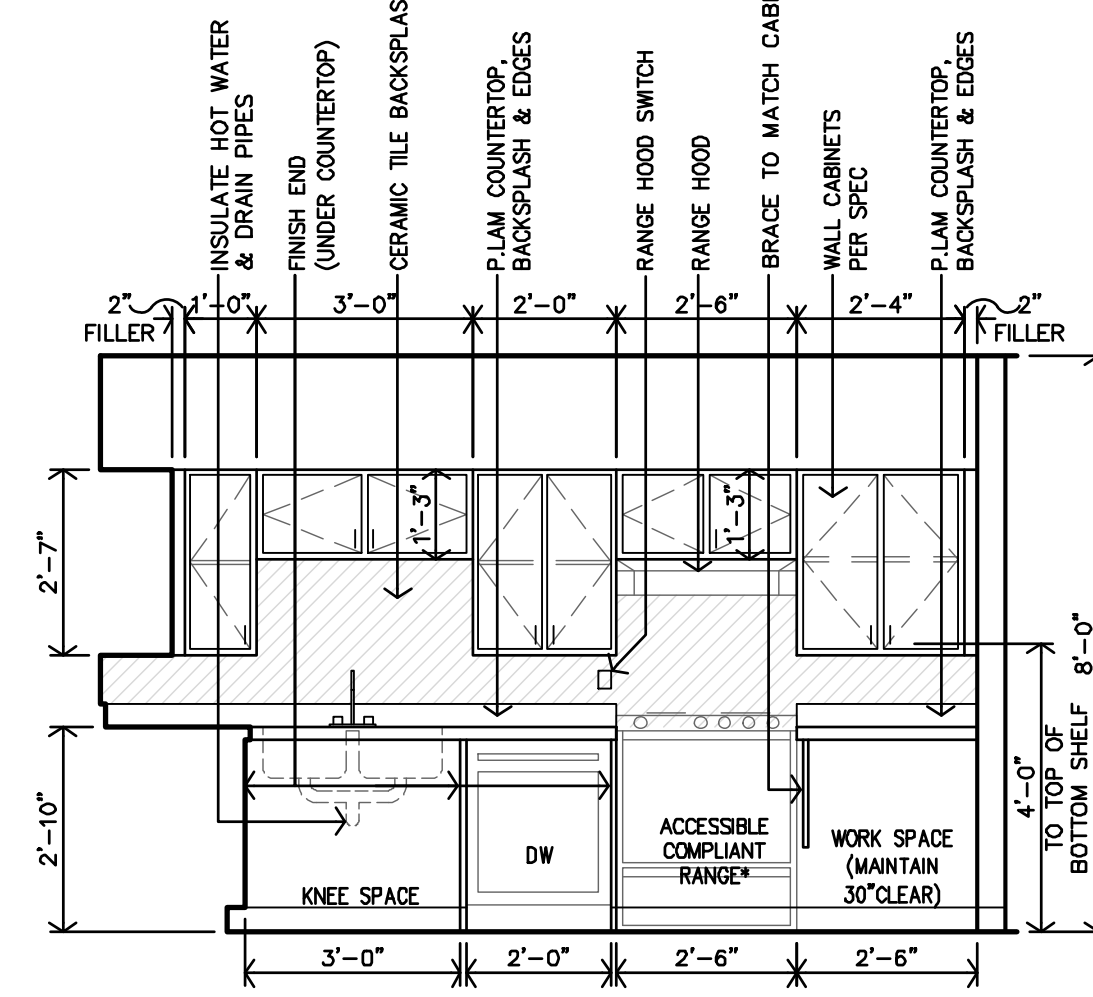

M UNIT 3A KITCHEN #3 INTERIOR ELEV.
3/8"=1'-0"

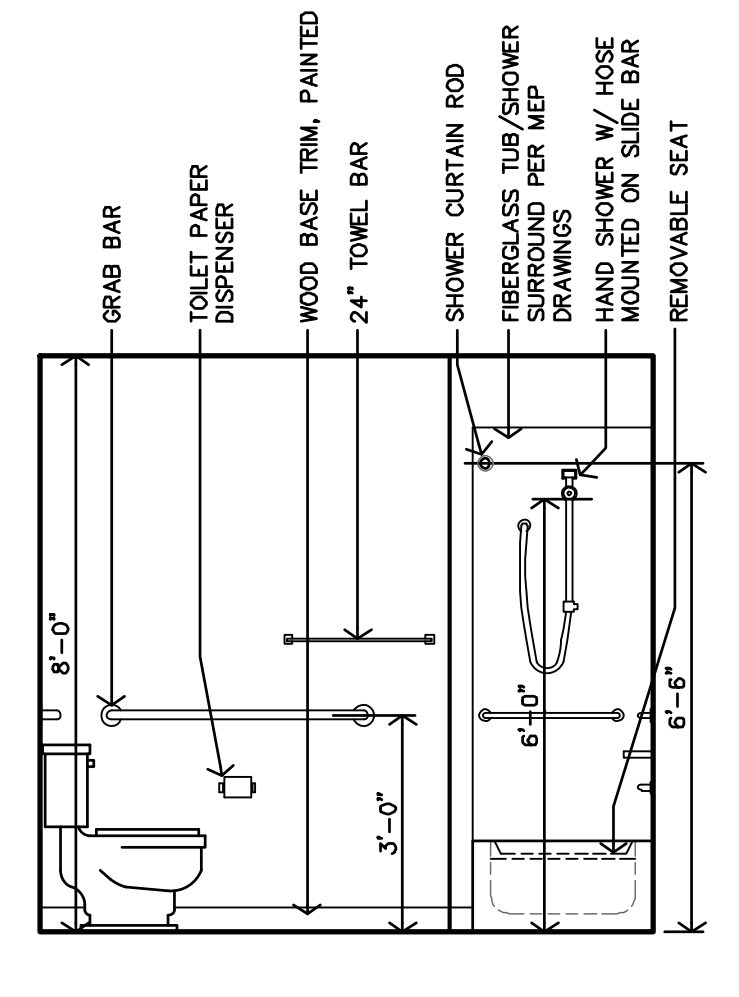

L UNIT 3A BATH #11 INTERIOR ELEV.
3/8"=1'-0"

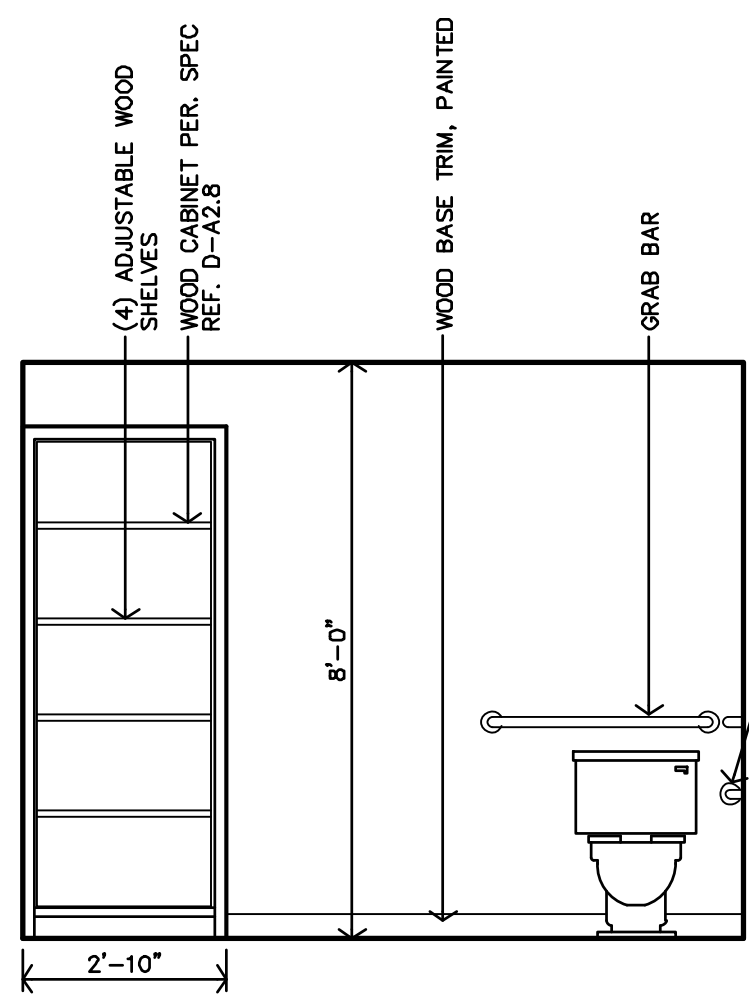

K UNIT 3A BATH #11 INTERIOR ELEV.
3/8"=1'-0"

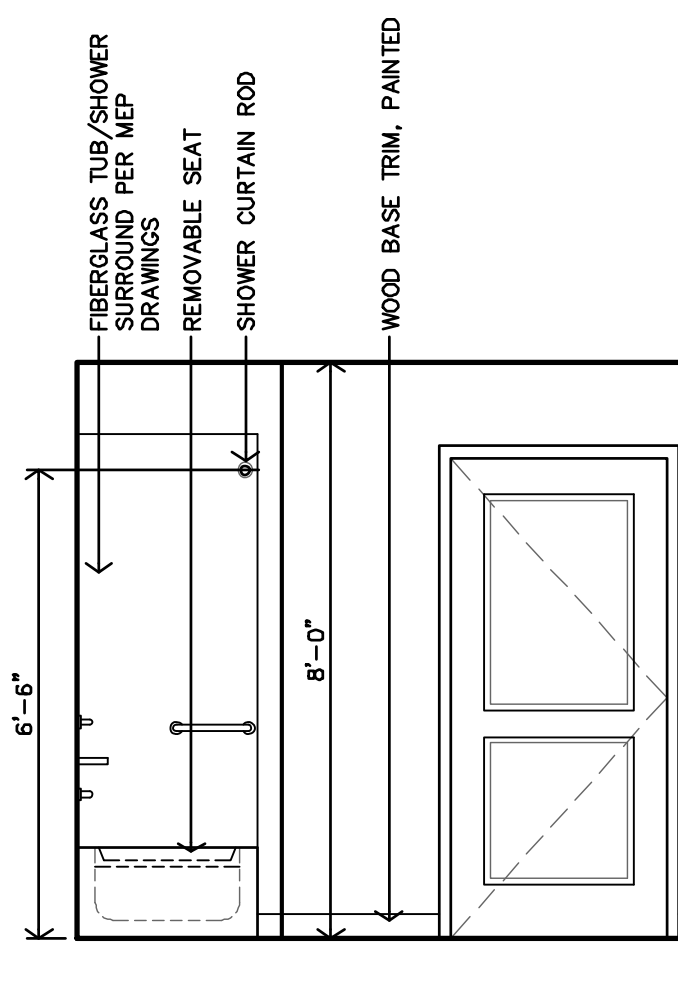

J UNIT 3A BATH #11 INTERIOR ELEV.
3/8"=1'-0"

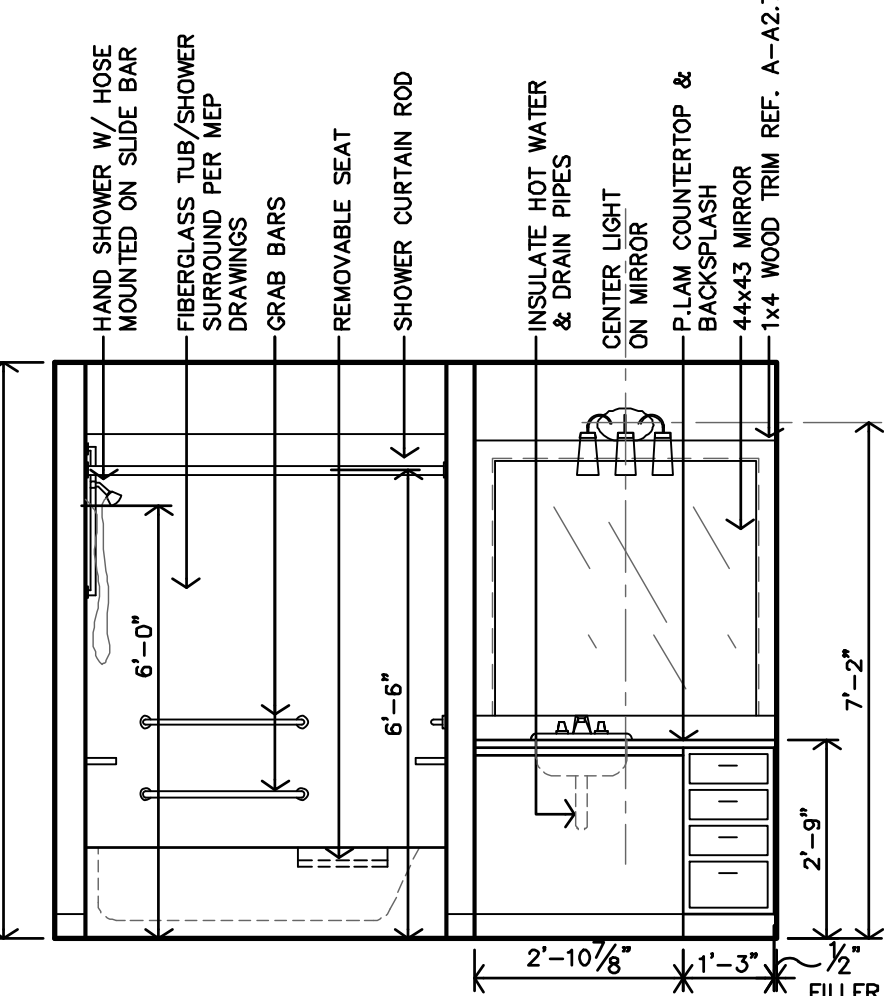

H UNIT 3A BATH #11 INTERIOR ELEV.
3/8"=1'-0"

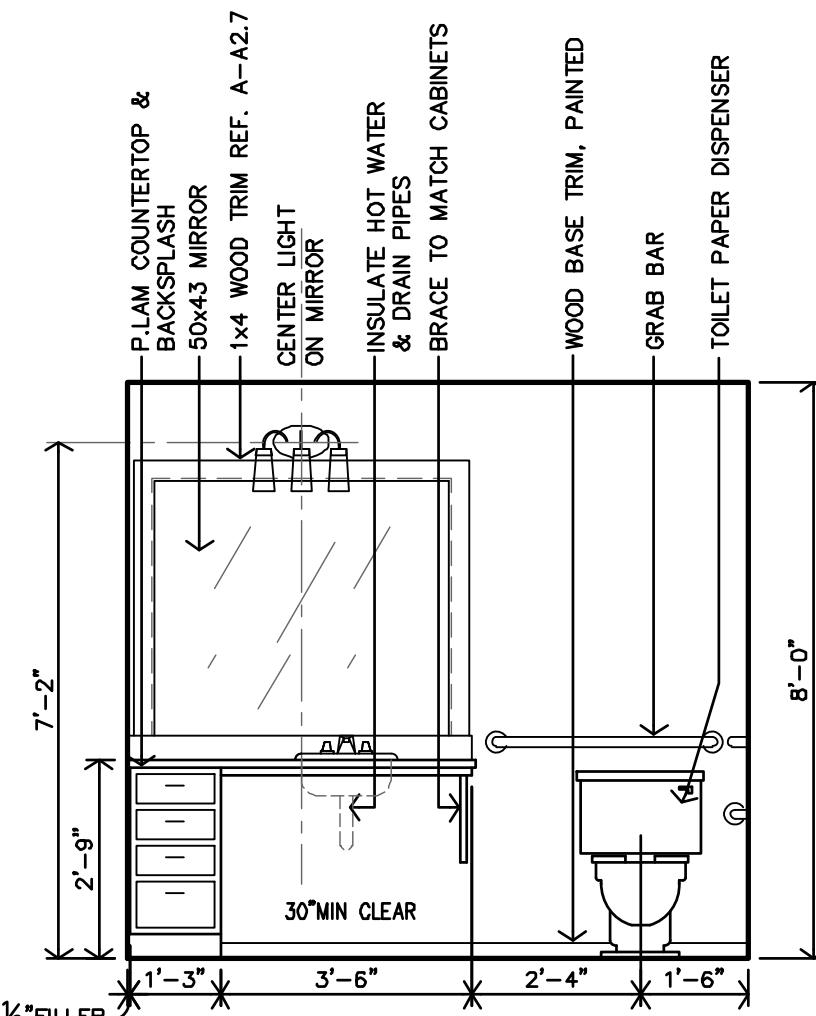

G UNIT 3A BATH #4 INTERIOR ELEV.
3/8"=1'-0"

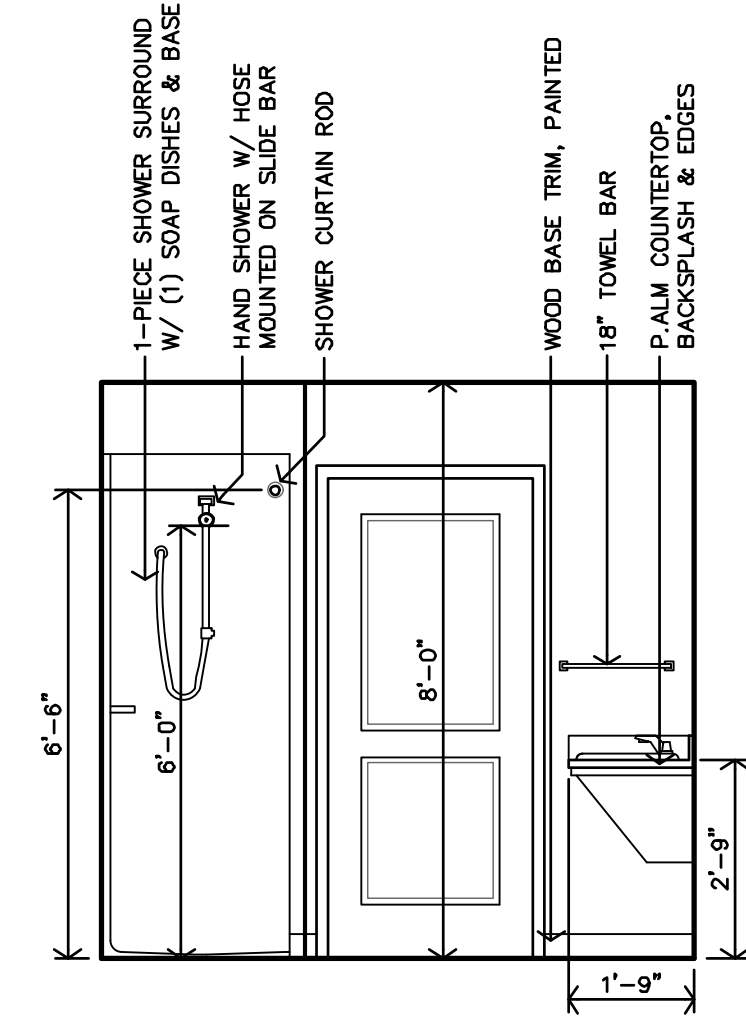

F UNIT 3A BATH #4 INTERIOR ELEV.
3/8"=1'-0"

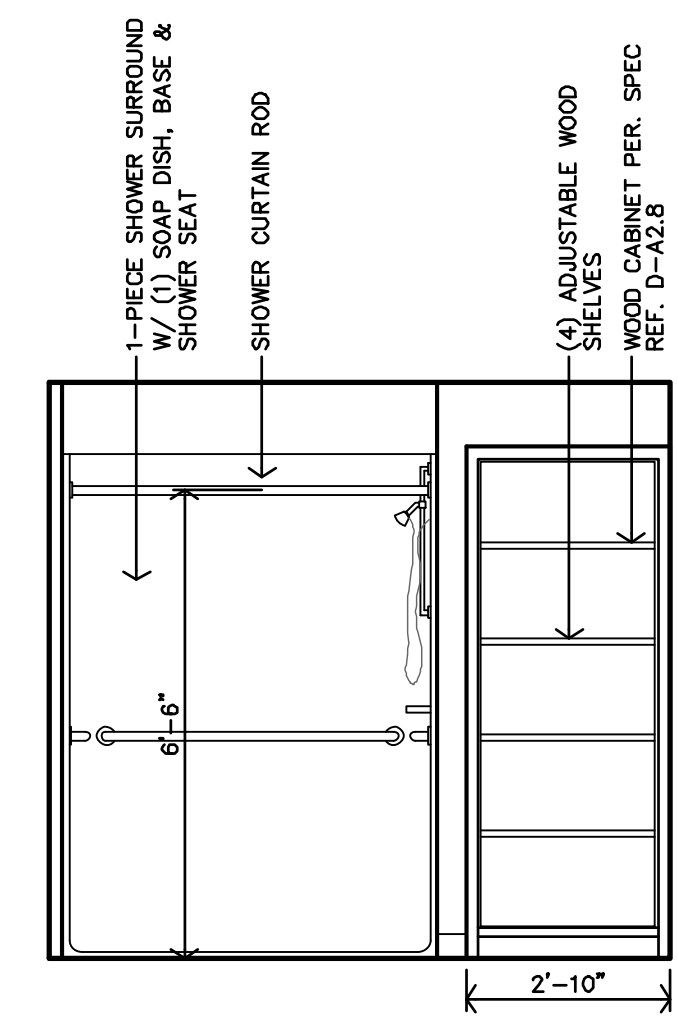

E UNIT 3A BATH #4 INTERIOR ELEV.
3/8"=1'-0"

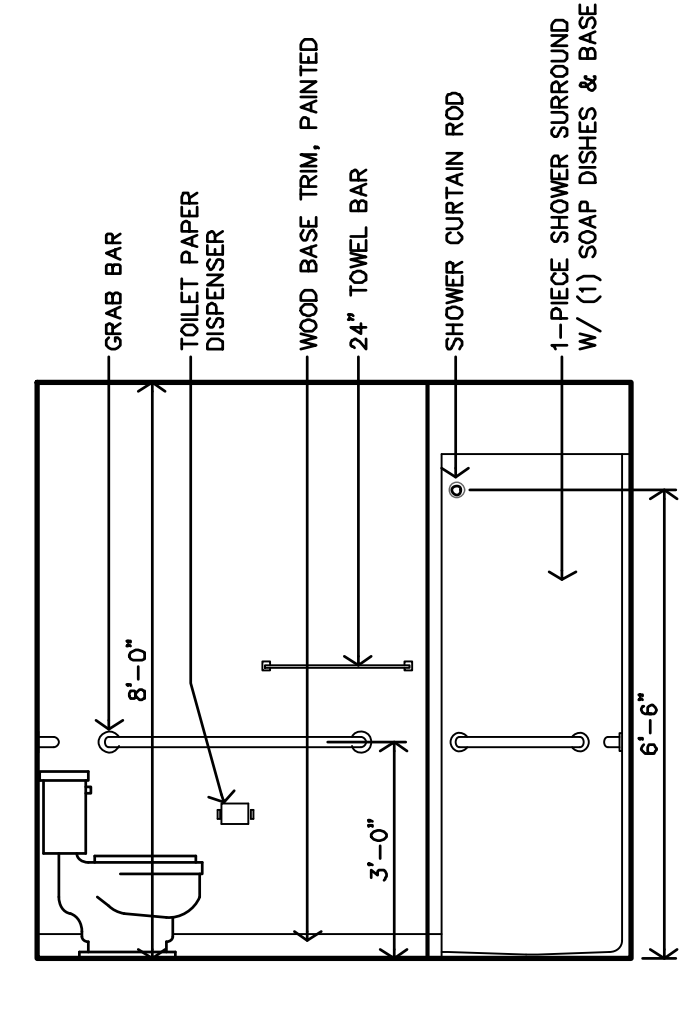

D UNIT 3A BATH #4 INTERIOR ELEV.
3/8"=1'-0"

ACCESSIBLE BATH NOTES

- REF APARTMENT GENERAL & ADAPTABLE UNIT NOTES ON SHEET A2.7 FOR ADDITIONAL DIRECTION.
- ALL DIMENSIONS ARE TO FACE OF CYP. BD. UNLESS NOTED OTHERWISE
- CONTRACTOR TO INSTALL 2x8 BLOCKING IN WALLS FOR ALL WALL MOUNTED/SUPPORTED COUNTERTOPS & BRACES, SHOWER UNIT, SLIDE BAR, TOWEL BARS, FUTURE GRABS BARS & FUTURE SHOWER SEAT, ETC. AS REQ'D. (REF. A2.7)
- LOCATION OF WASHER & DRYER IS CRITICAL. WASHER IS TO BE LEFT OF DRYER, ALWAYS. THIS NEEDS TO BE COORDINATED ON SITE ADAPTABLE & STANDARDS UNITS DESIGNED AROUND 27x42 WASHER & DRYER. ACCESSIBLE UNITS DESIGNED AROUND 27x33 WASHER & DRYER.

LEGEND

- M MIRROR
- TP TOWEL PAPER DISPENSER
- TB TOWEL BAR
- CL CORNER LEDGE
- SR SHOWER ROD
- SH SHOWER SEAT
- GB GRAB BAR

KEYNOTES:

- (A) PLASTIC COATED WIRE CLOTHES SHELF & ROD (HEIGHT AS CALLED OUT ON PLAN)
- (B) FLOORING TO BE CONTINUOUS @ SINK CABINETS & KITCHEN WORKSPACE
- (C) VERIFY SIZE W/ SHOWER UNIT
- (D) WATER HEATER - REF. MECH. DRAWINGS
- (E) NO CABINETS ABOVE WASHER & DRYER

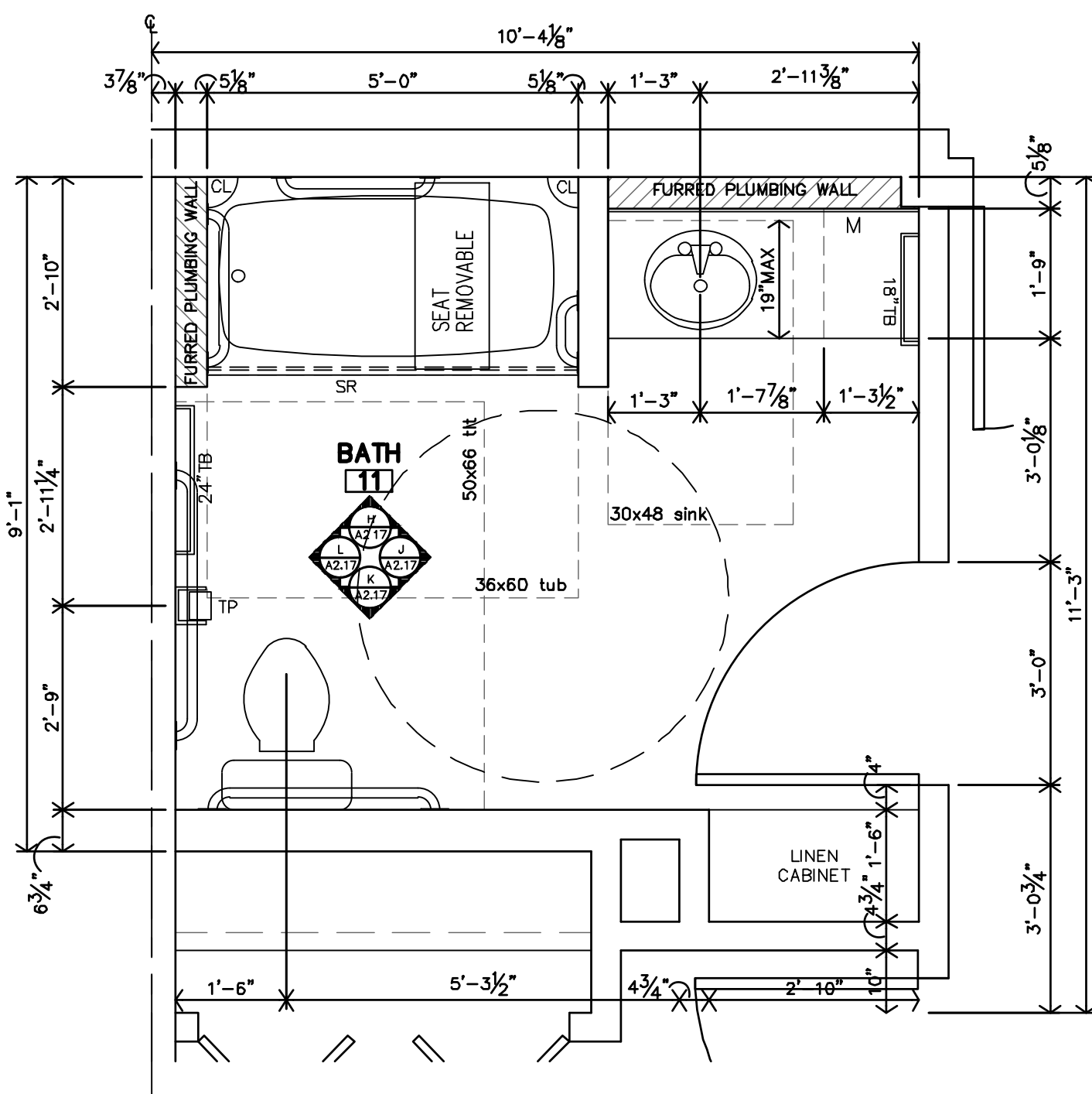

C 3A - ACCESSIBLE, 3 BEDROOM 2 BATH #11 ENLARGED PLAN
1/2"=1'-0"

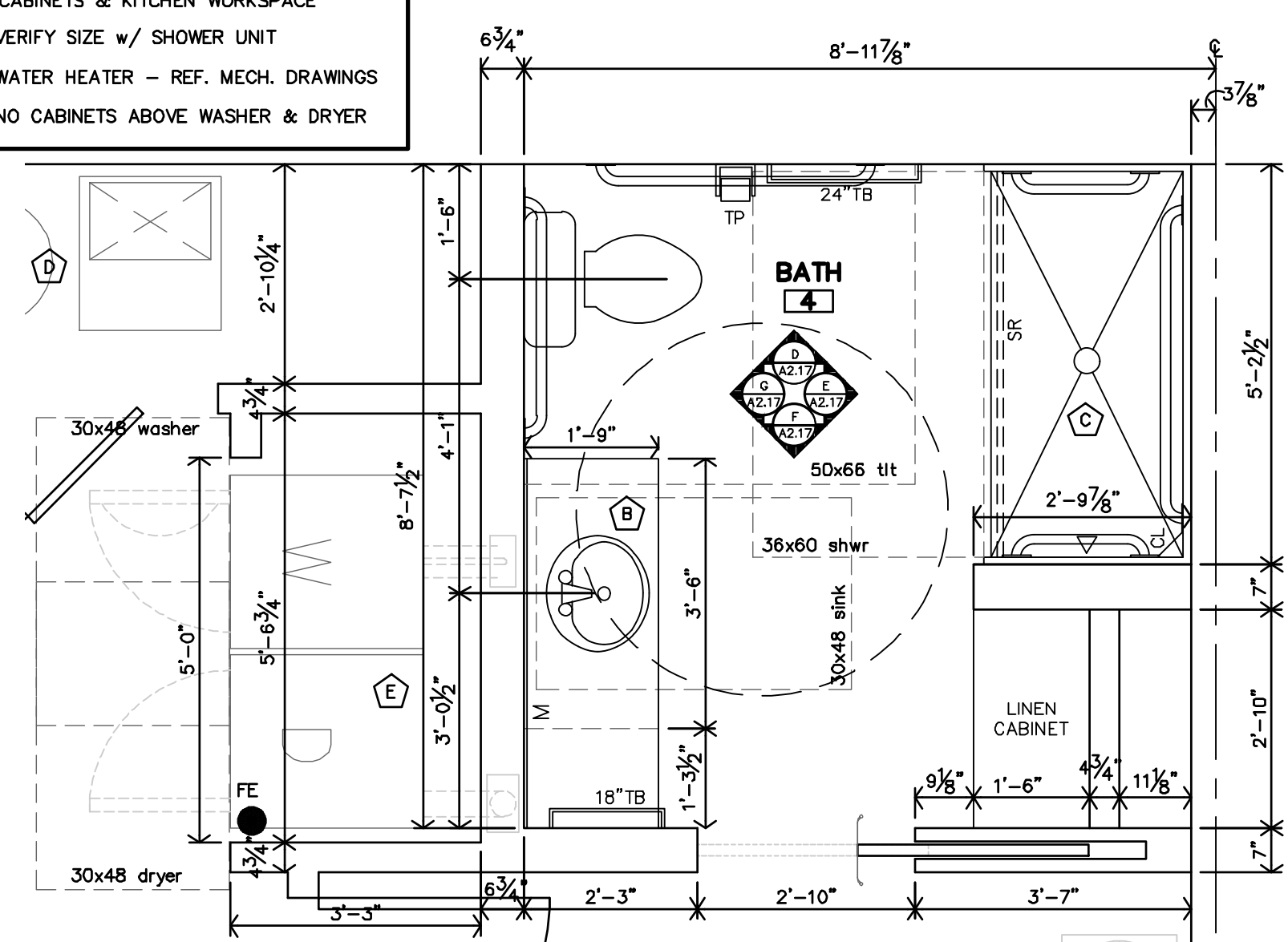

B UNIT 3A ACCESSIBLE BATH #4 ENLARGED PLAN
1/2"=1'-0"

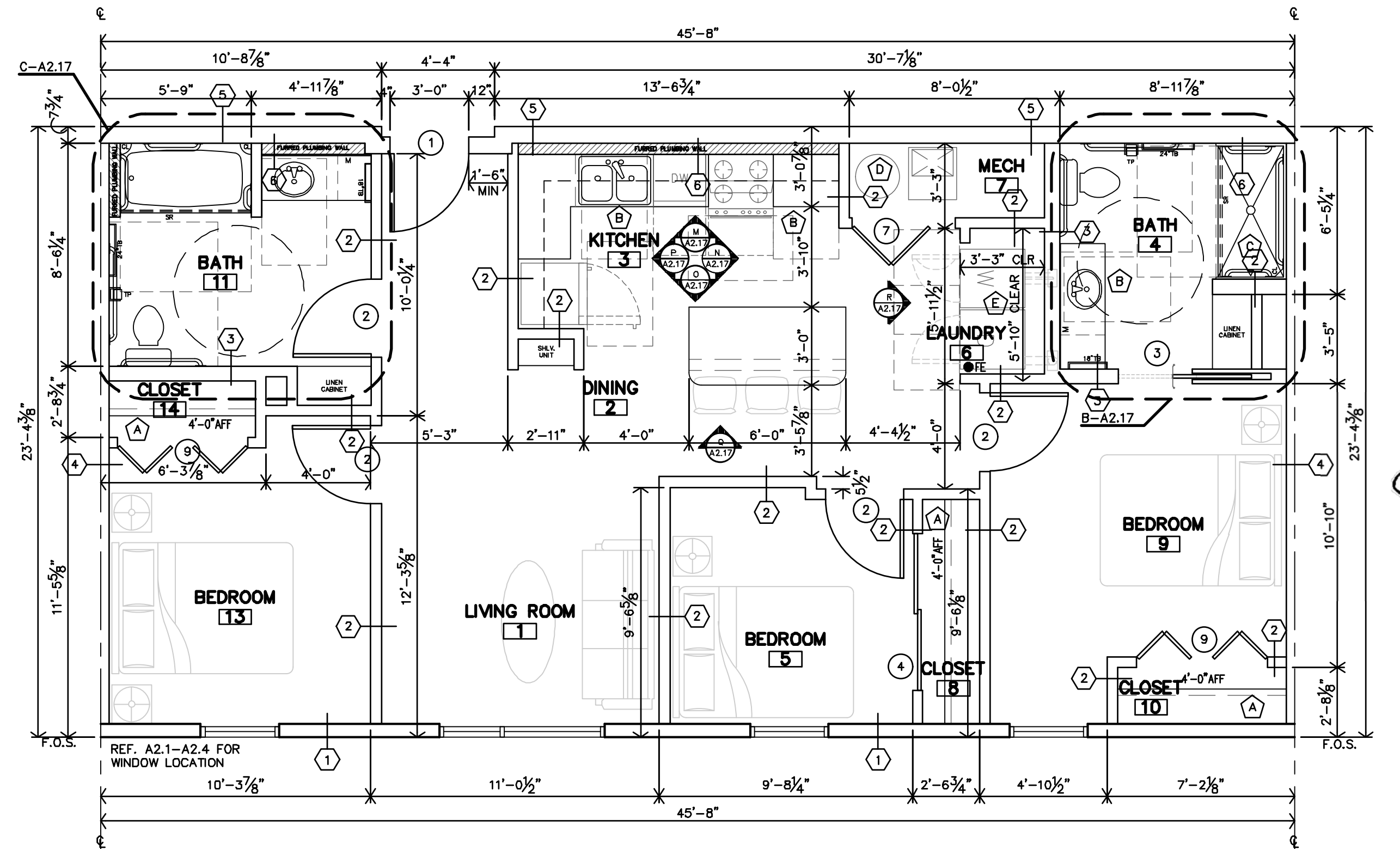

A UNIT 3A - ACCESSIBLE 3 BEDROOM - 2 BATH UNIT PLAN
1/4"=1'-0"



REVISION:	
DATE:	1-28-2022
JOB:	21-3137
SHEET:	

MASONRY FINISHES: BRICK BLEND 1 BRICK BLEND 2 PRECAST COLOR 3
FIBER CEMENT FINISHES: COLOR 1 COLOR 2 COLOR 3
PREFINISHED METAL: COLOR 1
TOTAL FACADE W/O GLAZING: 35,263 S.F. TOTAL BRICK: 11,910 S.F. BRICK MASONRY = 33%

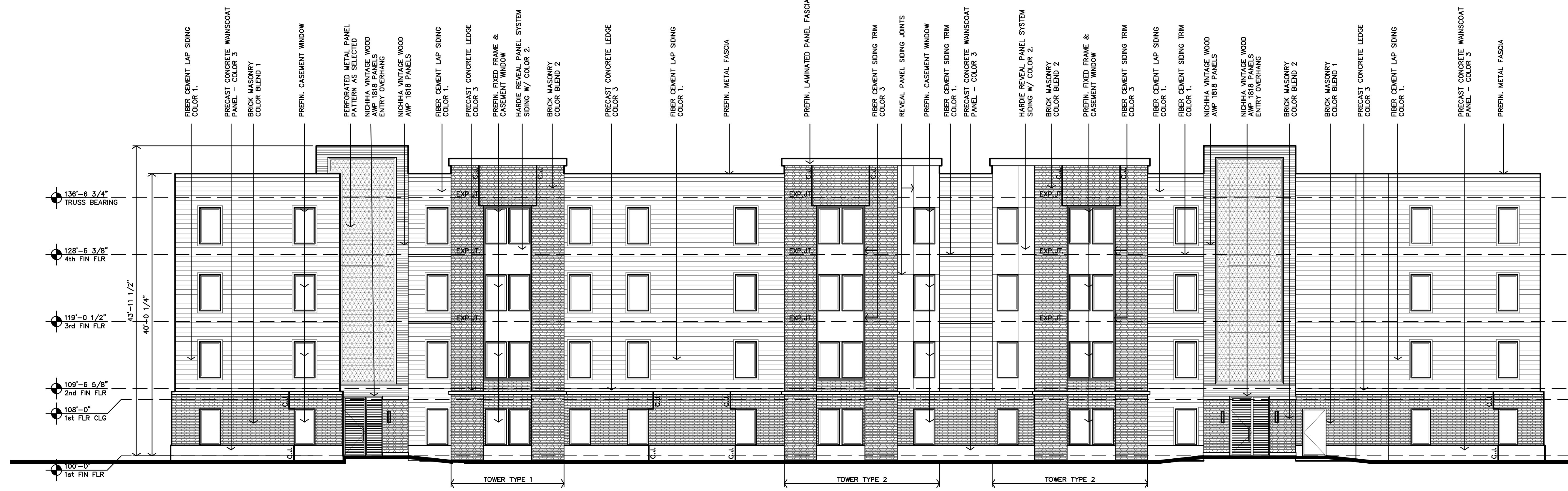

B EXTERIOR FACADE EAST ELEVATION
1/8"=1'-0"

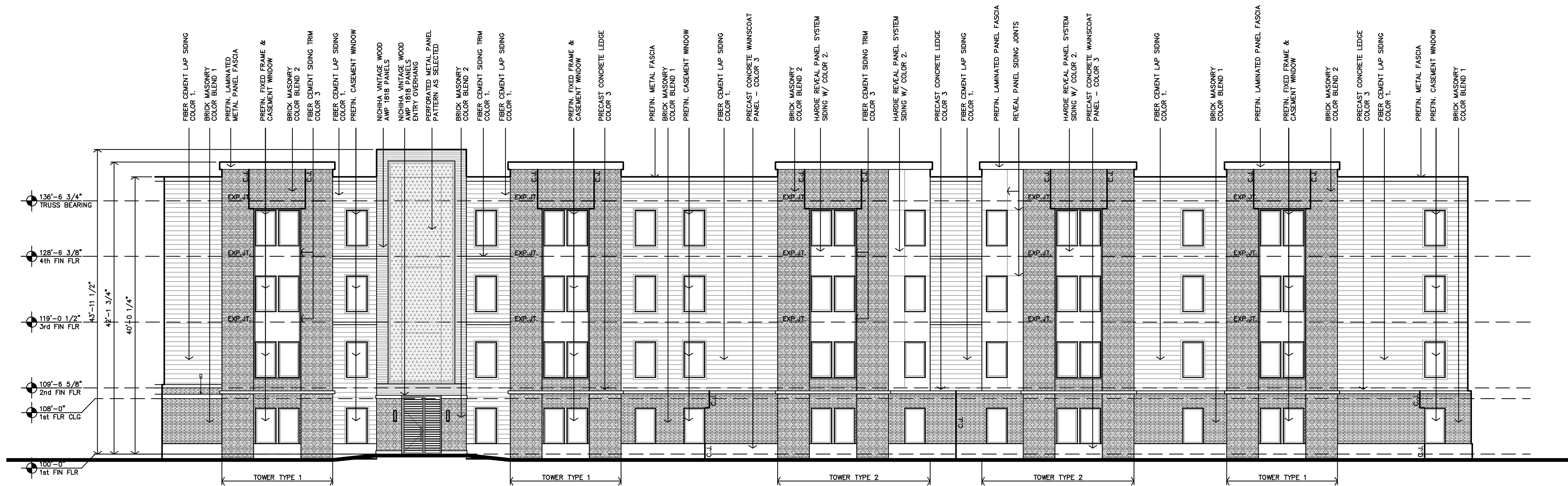

A EXTERIOR FACADE SOUTH ELEVATION
1/8"=1'-0"



REVISION:
DATE: 1-28-2022
JOB: 21-3137
SHEET:

A3.1

CLIFTON RIVERSIDE APARTMENTS
NEW APARTMENTS
FORT WORTH, TEXAS

Architects Planners Designers
730 N. Ninth
P.O. Box 2398
Selling, KS 67402
1881 Main Street, Suite 301
Kansas City, MO 64108
jpr@jprarchitects.com
785.827.0386

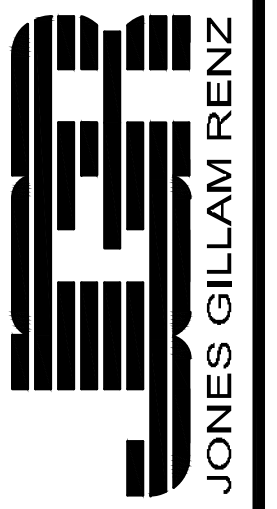

COPYRIGHTED ©

MASONRY FINISHES: BRICK BLEND 1 BRICK BLEND 2 PRECAST COLOR 3
FIBER CEMENT FINISHES: COLOR 1 COLOR 2 COLOR 3
REFINISHED METAL: COLOR 1
TOTAL FACADE W/O GLAZING: 35,263 S.F. TOTAL BRICK: 11,910 S.F. BRICK MASONRY = 33%



D TOWER TYPE 2 ENLARGED ELEVATION
3/16"=1'-0"

C TOWER TYPE 1 ENLARGED ELEVATION
3/16"=1'-0"

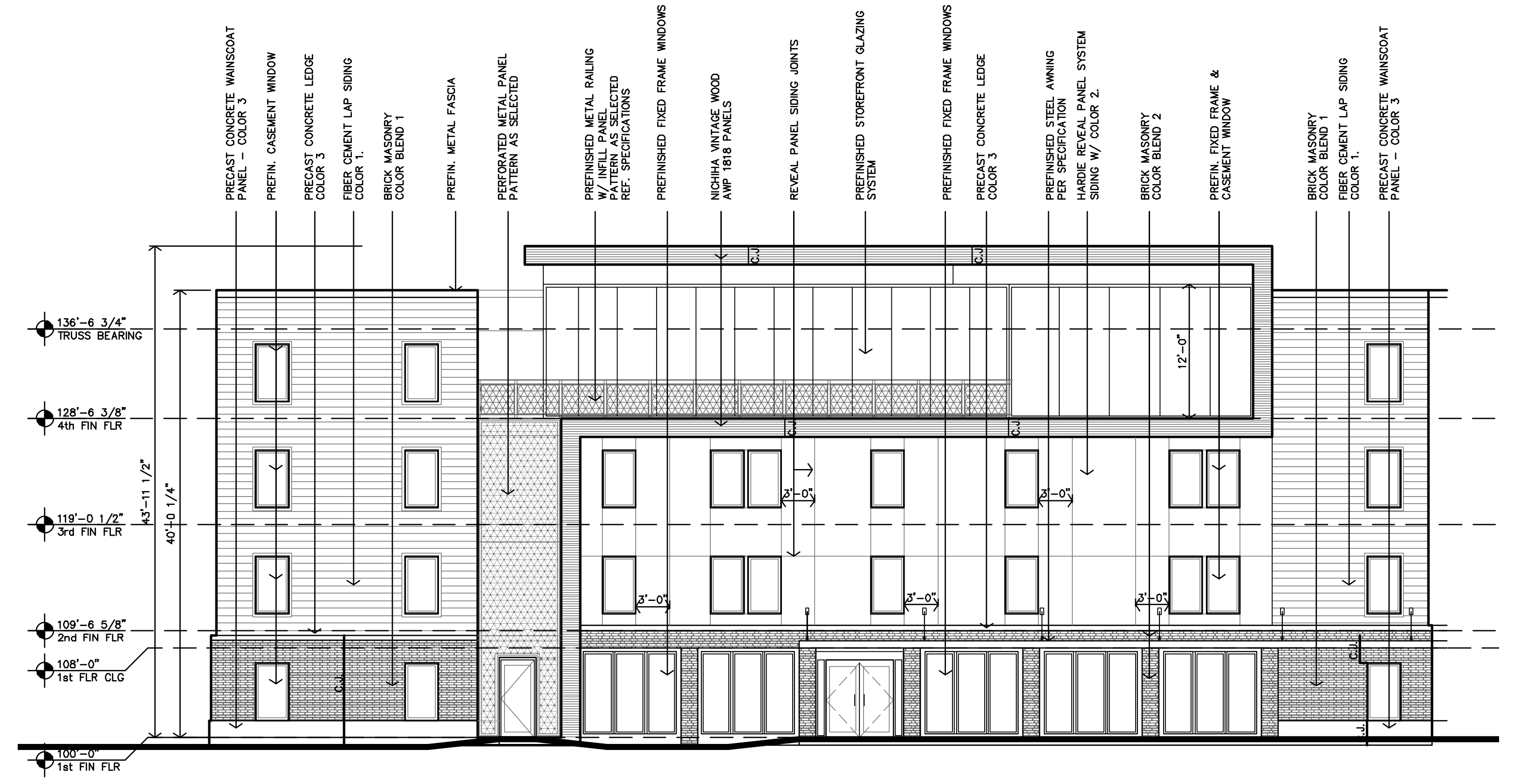

B EXTERIOR FACADE WEST ELEVATION
1/8"=1'-0"

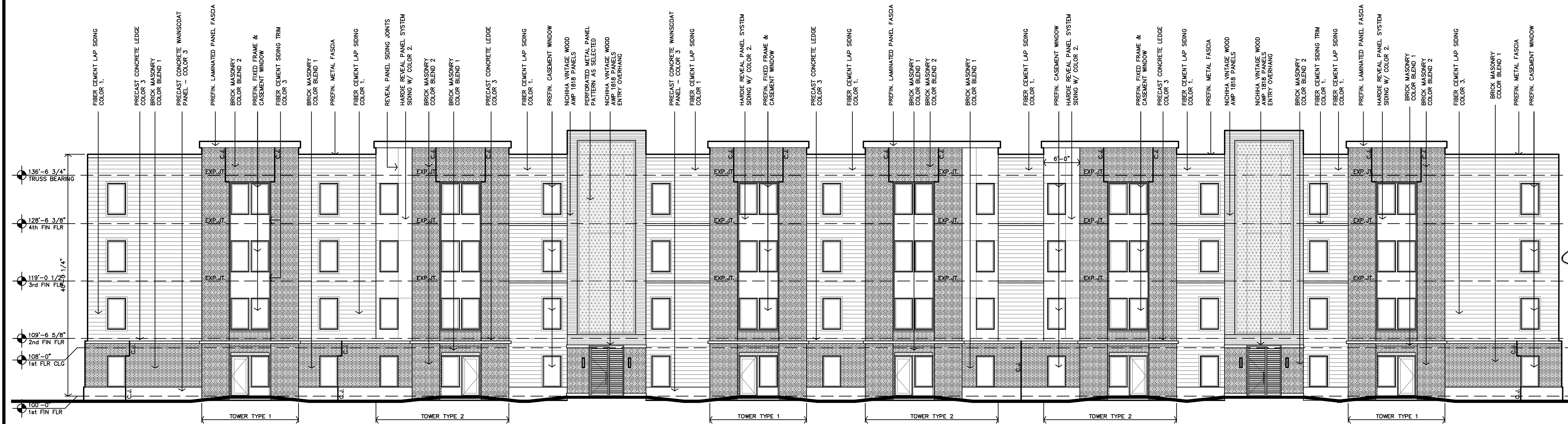

A EXTERIOR FACADE NORTH ELEVATION
1/8"=1'-0"



REVISION:
DATE: 1-28-2022
JOB: 21-3137
SHEET:

A3.2

CLIFTON RIVERSIDE APARTMENTS
NEW APARTMENTS
FORT WORTH, TEXAS

Architects Planners Designers
1881 Main Street, Suite 301
Kansas City, MO 64108
785.827.0396
jpr@jprarchitects.com

COPYRIGHTED ©

MASONRY FINISHES: BRICK BLEND 1 BRICK BLEND 2 PRECAST COLOR 3
FIBER CEMENT FINISHES: COLOR 1 COLOR 2 COLOR 3
PREFINISHED METAL: COLOR 1
TOTAL FACADE W/O GLAZING: 35,263 S.F. TOTAL BRICK: 11,910 S.F. BRICK MASONRY = 33%

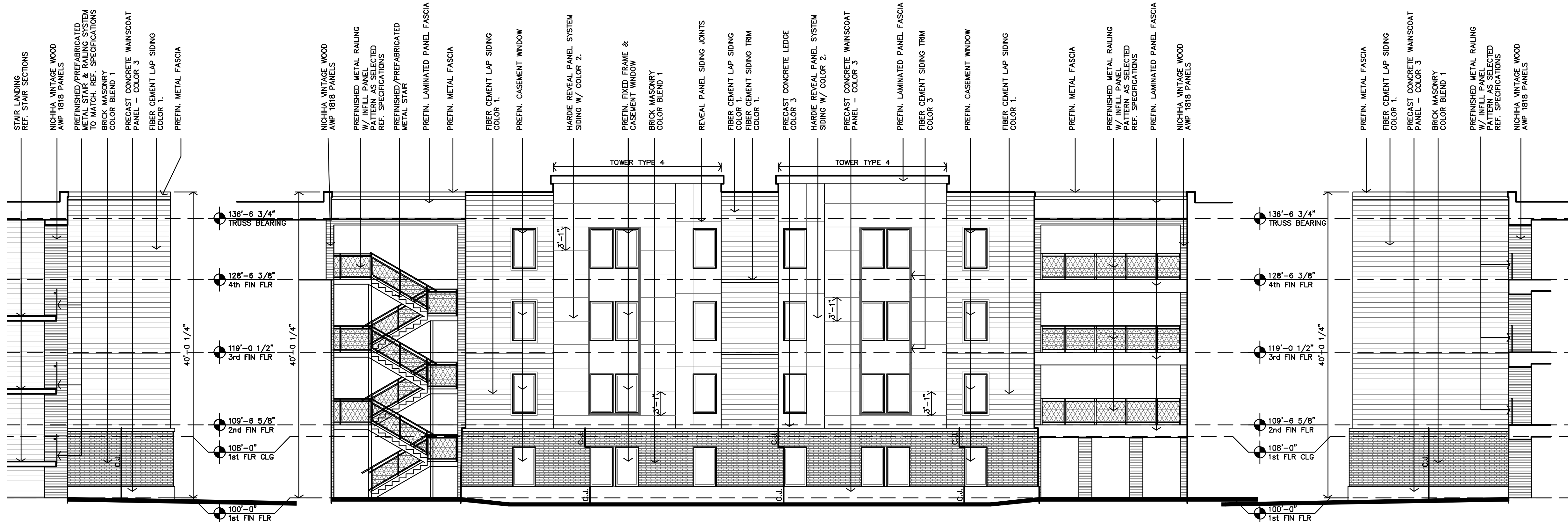

F COURTYARD FACADE WEST FACING ELEVATION
1/8"=1'-0"

E COURTYARD FACADE SOUTH FACING ELEVATION
1/8"=1'-0"

E COURTYARD FACADE EAST FACING ELEVATION
1/8"=1'-0"

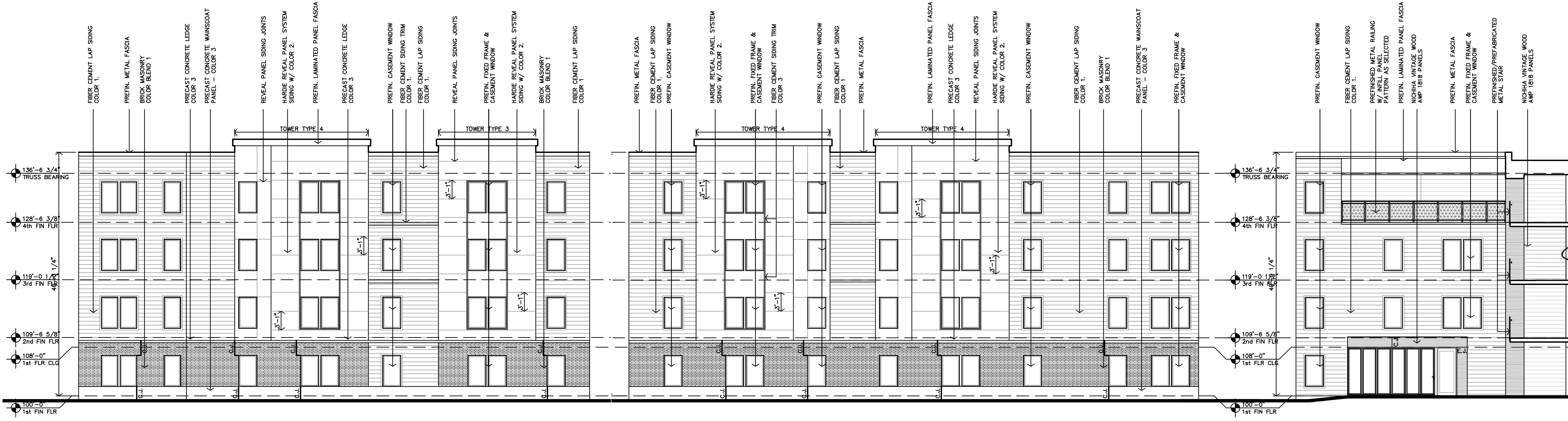

C COURTYARD FACADE WEST FACING ELEVATION
1/8"=1'-0"

B COURTYARD FACADE NORTH FACING ELEVATION
1/8"=1'-0"

A COURTYARD FACADE EAST FACING ELEVATION
1/8"=1'-0"



REVISION:
DATE: 1-28-2022
JOB: 21-3137
SHEET:

A3.3

Architects Planners Designers
1881 Main Street, Suite 301
Kansas City, MO 64108
785.827.0396
jgr@jgrarchitects.com

CLIFTON RIVERSIDE APARTMENTS
NEW APARTMENTS
TEXAS
JONES GILLAM RENZ

FORT WORTH,

COPYRIGHTED ©

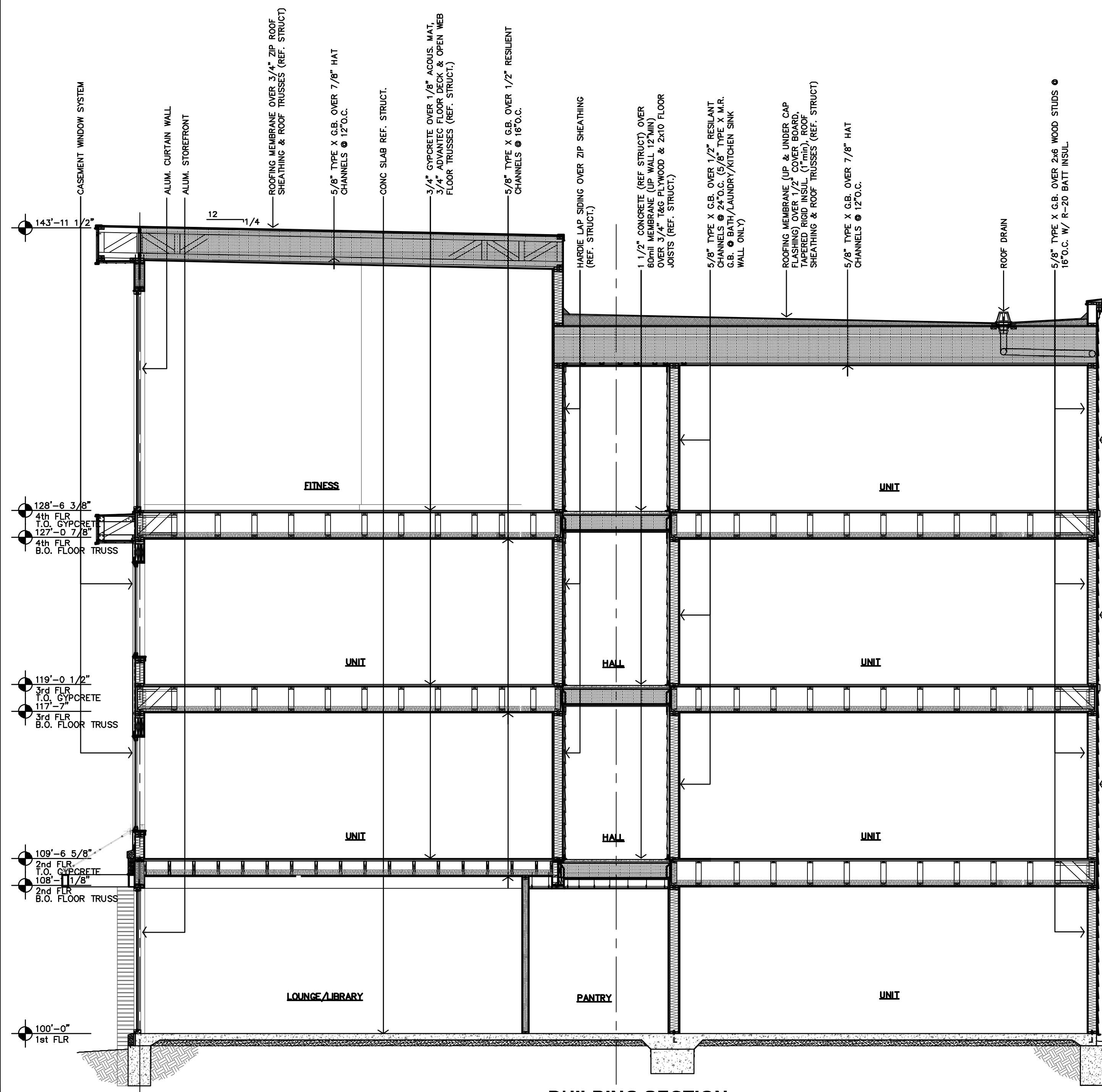

B BUILDING SECTION
1/4"=1'-0"

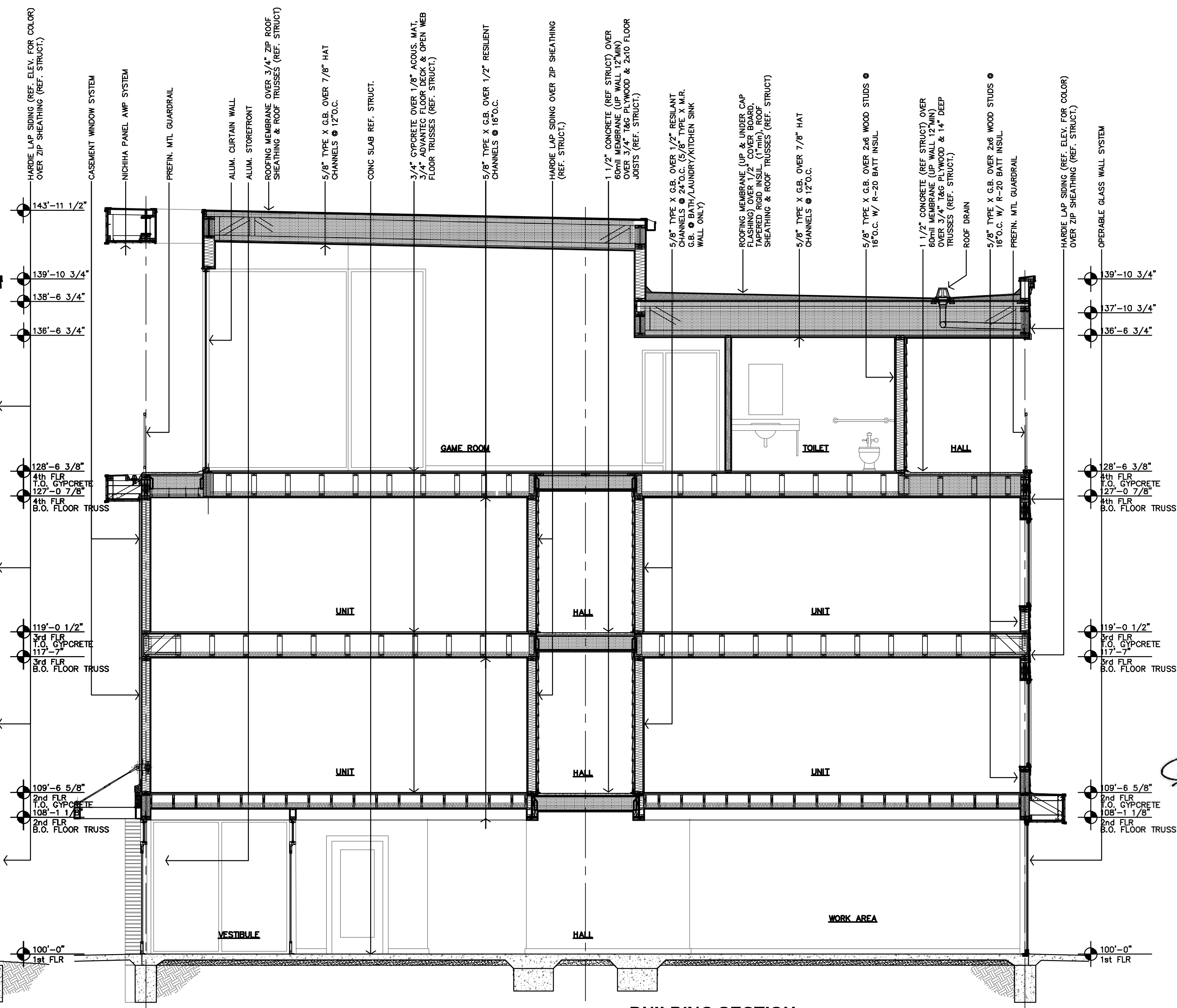

A BUILDING SECTION
1/4"=1'-0"



REVISION:	
DATE:	1-28-2022
JOB:	21-3137
SHEET:	

A3.4

COPYRIGHTED ©

CLIFTON RIVERSIDE APARTMENTS
NEW APARTMENTS
FORT WORTH, TEXAS

Architects Planners Designers
730 N. Ninth
P.O. Box 2928
Salina, KS 67402
jpr@jprarchitects.com

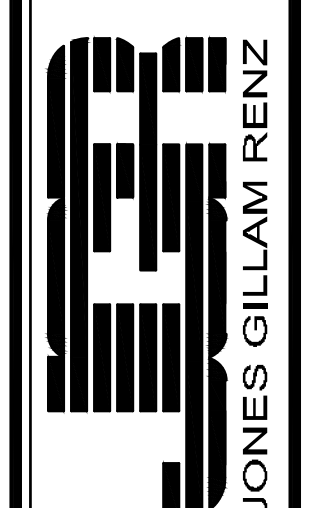

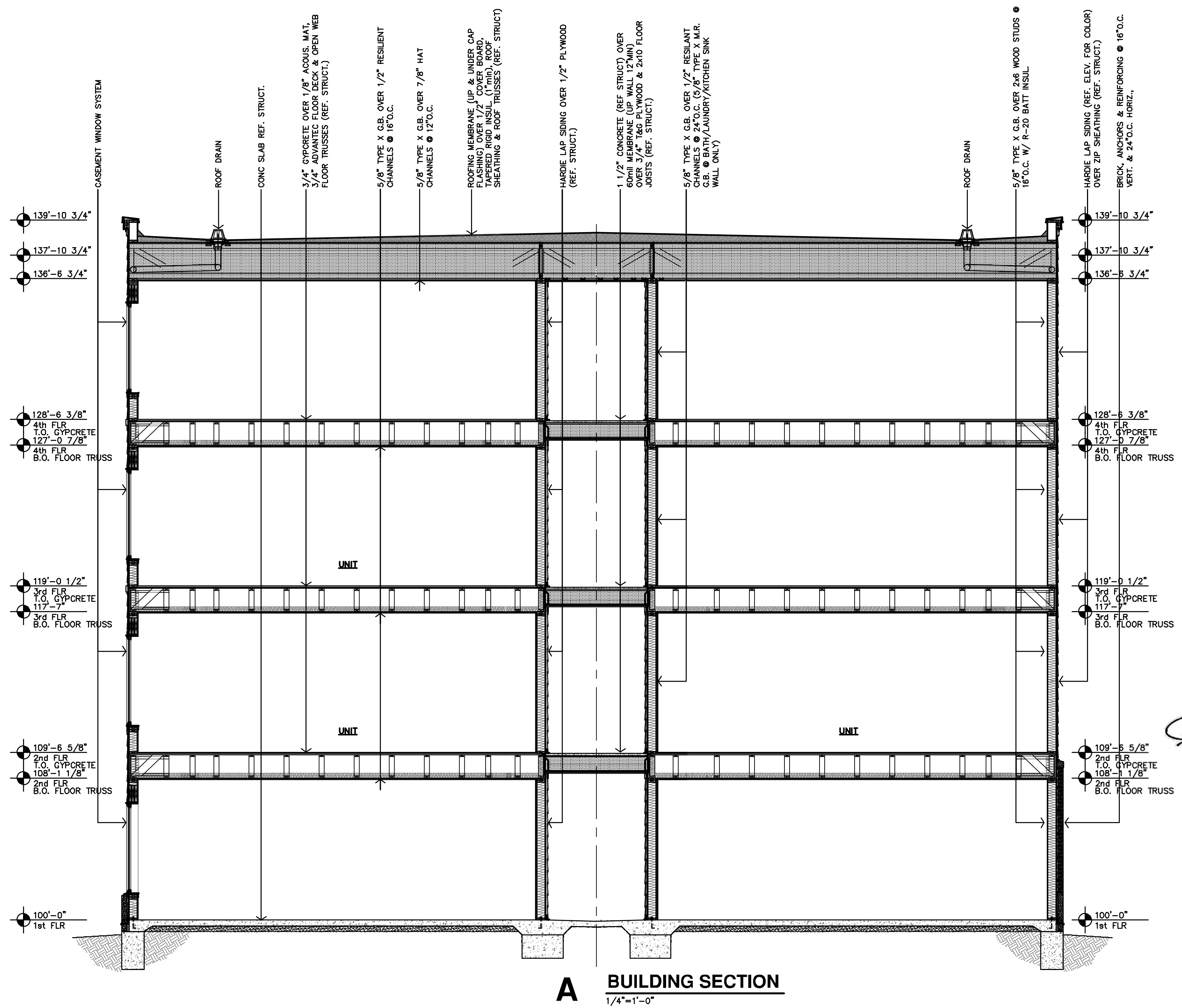

A BUILDING SECTION
 1/4"=1'-0"

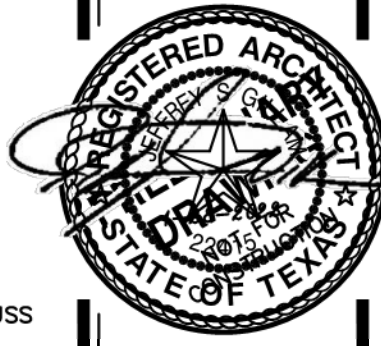

REVISION:	
DATE:	1-28-2022
JOB:	21-3137
SHEET:	

A3.5