

# FINAL DEVELOPMENT PLANS

## FOR

# ROOSEVELT LOFTS

### SAN ANGELO, TX

**UTILITIES**  
 SANITARY SEWER AND WATER  
 CITY OF SAN ANGELO  
 CITY HALL ANNEX, FIRST FLOOR  
 301 W. BEAUREGARD AVE.  
 SAN ANGELO, TX 76903  
 325-657-4209

**ELECTRIC SERVICE**  
 AEP TEXAS  
 877-373-4858

**COMMUNICATIONS**  
 OPTIMUM  
 877-694-9474

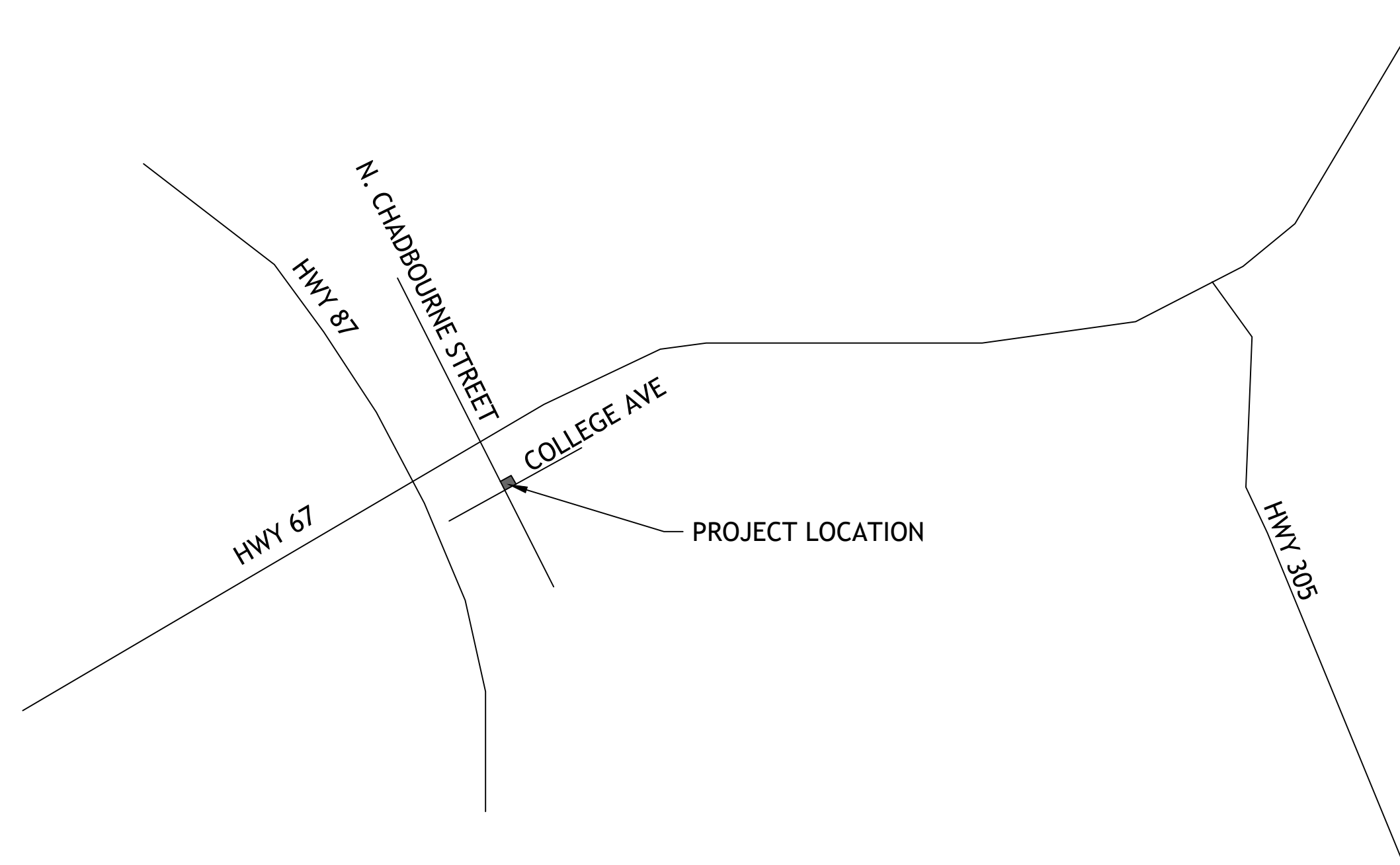

LOCATION MAP

#### INDEX OF SHEETS

- C-1 COVER SHEET
- C-2 EXISTING CONDITIONS
- C-3 DEMOLITION PLAN
- C-4 SITE PLAN
- C-5 UTILITY PLAN
- C-6 GRADING PLAN
- C-7 GRADING PLAN
- C-8 DETAILS

SM Engineering  
**SME**  
 5507 High Meadow Circle  
 Manhattan Kansas, 66503  
 smcivilengr@gmail.com  
 785.341.9747

SM ENGINEERING  
 TEXAS ENGINEERING FIRM  
 F-21697  
 Drawings and/or Specifications are original  
 proprietary work and property of the  
 Engineer and intended specifically for this  
 project. Use of items contained herein  
 without consent of the Engineers is  
 prohibited. Drawings illustrate best  
 information available to the Engineer. Field  
 verification of actual elements, conditions,  
 and dimensions is required.

Revisions

#### OWNER/DEVELOPER

OPG RIDGEMOUNT PARTNERS, LLC  
 NATE MILLER, DIRECTOR OF DEVELOPMENT  
 5341 W. 151st TERRACE  
 LEAWOOD, KS 66224  
 785-493-1130

#### SURVEYOR

MDS LAND SURVEYING  
 874 HARPER RD, SUITE 104  
 KERRVILLE, TX 78028  
 830-816-1818

#### ENGINEER

SM ENGINEERING  
 5507 HIGH MEADOW CIRCLE  
 MANHATTAN KANSAS, 66503  
 SMCIVILENGR@GMAIL.COM  
 785.341.9747

#### UTILITY STATEMENT:

THE UNDERGROUND UTILITIES SHOWN HEREON ARE FROM FIELD SURVEY INFORMATION OF ONE-CALL LOCATED UTILITIES, FIELD SURVEY INFORMATION OF ABOVE GROUND OBSERVABLE EVIDENCE, AND/OR THE SCALING AND PLOTTING OF EXISTING UTILITY MAPS AND DRAWINGS AVAILABLE TO THE SURVEYOR AT THE TIME OF SURVEY. THE SURVEYOR MAKES NO GUARANTEE THAT THE UNDERGROUND UTILITIES SHOWN COMPRISE ALL SUCH UTILITIES IN THE AREA, EITHER IN SERVICE OR ABANDONED. FURTHERMORE, THE SURVEYOR DOES NOT WARRANT THAT THE UNDERGROUND UTILITIES SHOWN ARE IN THE EXACT LOCATION INDICATED ALTHOUGH HE DOES CERTIFY THAT THEY ARE LOCATED AS ACCURATELY AS POSSIBLE FROM INFORMATION AVAILABLE. THE SURVEYOR HAS NOT PHYSICALLY LOCATED THE UNDERGROUND UTILITIES BY EXCAVATION UNLESS OTHERWISE NOTED ON THIS SURVEY.

#### SAFETY NOTICE TO CONTRACTOR

IN ACCORDANCE WITH GENERALLY ACCEPTED CONSTRUCTION PRACTICE, THE CONTRACTOR WILL BE SOLELY AND COMPLETELY RESPONSIBLE FOR CONDITIONS OF THE JOB SITE, INCLUDING SAFETY OF ALL PERSONS AND PROPERTY DURING PERFORMANCE OF THE WORK. THIS REQUIREMENT WILL APPLY CONTINUOUSLY AND NOT BE LIMITED TO NORMAL WORKING HOURS.

#### WARRANTY/DISCLAIMER

THE DESIGNS REPRESENTED IN THESE PLANS ARE IN ACCORDANCE WITH ESTABLISHED PRACTICES OF CIVIL ENGINEERING FOR THE DESIGN FUNCTIONS AND USES INTENDED BY THE OWNER AT THIS TIME. HOWEVER, NEITHER SM ENGINEERING, INC NOR ITS PERSONNEL CAN OR DO WARRANTY THESE DESIGNS OR PLANS AS CONSTRUCTED, EXCEPT IN THE SPECIFIC CASES WHERE SM ENGINEERING PERSONNEL INSPECT AND CONTROL THE PHYSICAL CONSTRUCTION ON A CONTEMPORARY BASIS AT THE SITE.

#### CAUTION- NOTICE TO CONTRACTOR

THE CONTRACTOR IS SPECIFICALLY CAUTIONED THAT THE LOCATION AND/OR ELEVATION OF EXISTING UTILITIES AS SHOWN ON THESE PLANS IS BASED ON RECORDS OF THE VARIOUS UTILITY COMPANIES AND, WHERE POSSIBLE, MEASUREMENTS TAKEN IN THE FIELD. THE INFORMATION IS NOT TO BE RELIED ON AS BEING EXACT OR COMPLETE. THE CONTRACTOR MUST CALL THE APPROPRIATE UTILITY COMPANY AT LEAST 72 HOURS BEFORE ANY EXCAVATION TO REQUEST EXACT FIELD LOCATION OF UTILITIES. IT SHALL BE THE RESPONSIBILITY OF THE CONTRACTOR TO RELOCATE ALL EXISTING UTILITIES WHICH CONFLICT WITH PROPOSED IMPROVEMENTS SHOWN ON THE PLANS. THE CONTRACTOR SHALL EXPOSE EXISTING UTILITIES AT LOCATIONS OF POSSIBLE CONFLICTS PRIOR TO ANY CONSTRUCTION.

#### LEGAL DESCRIPTION

TRACT ONE: A 0.221 ACRE (9,606 SQUARE FEET) TRACT OUT OF LOTS 8 AND 9, BLOCK 43, MAIN PART OF THE CITY OF SAN ANGELO, TOM GREEN COUNTY, TEXAS AS CONVEYED TO FIRESIDE PARTNERS, LLC BY SPECIAL WARRANTY DEED RECORDED IN DOCUMENT NO. 201615534, OFFICIAL PUBLIC RECORDS OF TOM GREEN COUNTY, TEXAS.

TRACT TWO: A 0.101 ACRE (4,412 SQUARE FEET) TRACT OUT OF LOT 7, BLOCK 43, MAIN PART OF THE CITY OF SAN ANGELO, TOM GREEN COUNTY, TEXAS AS CONVEYED TO FIRESIDE PARTNERS, LLC BY SPECIAL WARRANTY DEED RECORDED IN DOCUMENT NO. 201615534, OFFICIAL PUBLIC RECORDS OF TOM GREEN COUNTY, TEXAS.

TRACT THREE: A 0.064 ACRE (2,772 SQUARE FEET) TRACT OUT OF ACRE LOTS 6 AND 7, MILES ADDITION, CITY OF SAN ANGELO, TOM GREEN COUNTY, TEXAS AS CONVEYED TO FIRESIDE PARTNERS, LLC BY SPECIAL WARRANTY DEED RECORDED IN DOCUMENT NO. 201615534, OFFICIAL PUBLIC RECORDS OF TOM GREEN COUNTY, TEXAS.

TRACT FOUR: A 0.104 ACRE (4,517 SQUARE FEET) TRACT OUT OF ACRE LOT 7, MILES ADDITION, CITY OF SAN ANGELO, TOM GREEN COUNTY, TEXAS AS CONVEYED TO FIRESIDE PARTNERS, LLC BY SPECIAL WARRANTY DEED RECORDED IN DOCUMENT NO. 201615534, OFFICIAL PUBLIC RECORDS OF TOM GREEN COUNTY, TEXAS.

TRACT FIVE: A 0.005 ACRE (198 SQUARE FEET) TRACT OUT OF ACRE LOT 7, MILES ADDITION, CITY OF SAN ANGELO, TOM GREEN COUNTY, TEXAS AS CONVEYED TO FIRESIDE PARTNERS, LLC BY DEED WITHOUT WARRANTY RECORDED IN DOCUMENT NO. 202016755, OFFICIAL PUBLIC RECORDS OF TOM GREEN COUNTY, TEXAS.

TRACT SIX: A 0.002 ACRE (90 SQUARE FEET) TRACT OF ABANDONED STREET RIGHT-OF-WAY AS CONVEYED TO FIRESIDE PARTNERS, LLC BY QUITCLAIM DEED RECORDED IN DOCUMENT NO. 202016754, OFFICIAL PUBLIC RECORDS OF TOM GREEN COUNTY, TEXAS.

TRACT SEVEN: A 0.020 ACRE (860 SQUARE FEET) TRACT BEING THE EAST 10' OF THE EAST 30' OF LOT 8, BLOCK 43, MAIN PART OF THE CITY OF SAN ANGELO, TOM GREEN COUNTY, TEXAS AS CONVEYED TO FIRESIDE PARTNERS, LLC BY QUITCLAIM DEED RECORDED IN DOCUMENT NO. 201815800, OFFICIAL PUBLIC RECORDS OF TOM GREEN COUNTY, TEXAS.

ROOSEVELT LOFTS  
 50 N CHADBOURNE STREET  
 SAN ANGELO, TX 76903



SAMUEL D. MALINOWSKY  
 PROFESSIONAL ENGINEER

sheet  
**C1.0**  
 Civil  
 COVER SHEET  
 permit  
 16 JANUARY 2024

- 1/2" IRON ROD FOUND CAPPED "SKG"
- BUILDING CORNER
- CALCULATED POINT
- DRILL HOLE FOUND
- CLEAN OUT
- GAS METER
- GUY ANCHOR
- LIGHT POLE
- METER POLE
- POWER POLE
- SANITARY SEWER MANHOLE
- SIGN
- STORM DRAIN MANHOLE
- TRAFFIC SIGNAL POLE
- WATER METER
- WATER VALVE
- ( ) RECORD BEARING & DISTANCE
- (DI) DRAIN INLET
- DOC. DOCUMENT
- D.R. DEED RECORDS OF TOM GREEN COUNTY
- FT. FEET
- NO. NUMBER
- O.P.R. OFFICIAL PUBLIC RECORDS OF TOM GREEN COUNTY
- PC PAGE
- POB POINT OF BEGINNING
- SQ. SQUARE
- VOL. VOLUME
- ASPHALT
- CONCRETE
- ADJOINER LINE
- BOUNDARY LINE
- CHAIN LINK FENCE
- LOT LINE
- OVERHEAD POWER
- PIPE FENCE
- SURVEY LINE

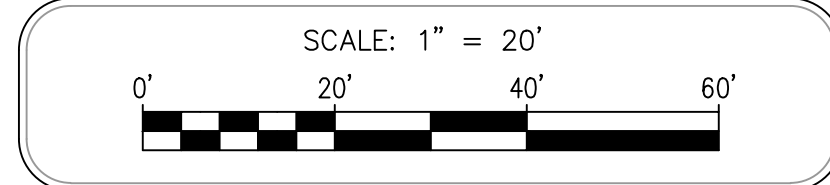
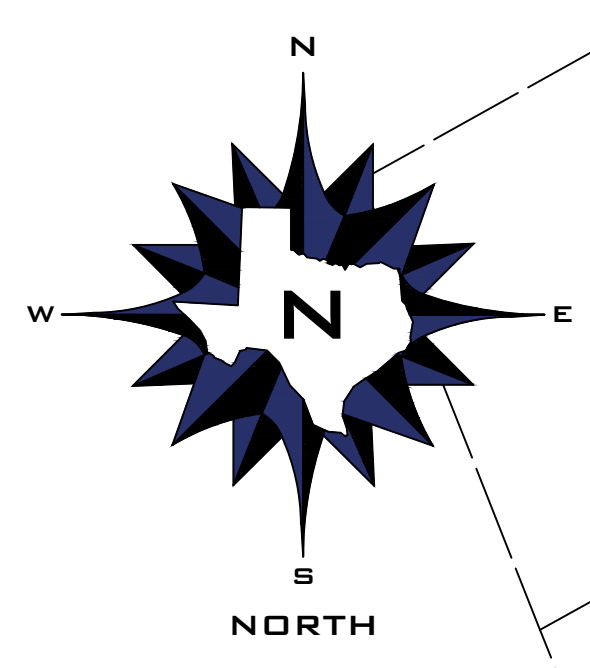

LINE	BEARING	DISTANCE
L1	S 21°20'36" E	19.97'
L2	N 21°34'57" W	19.97'
L3	N 61°15'22" E	10.00'
L4	S 21°10'58" E	20.00'
L5	S 61°15'22" W	10.00'
L6	N 21°10'58" W	20.00'
L7	S 70°40'47" W	9.97'
L8	N 19°18'51" W	85.41'
L9	N 61°15'22" E	10.11'
L10	S 19°18'51" E	87.06'
L11	N 70°39'23" E	4.00'
L12	S 22°02'07" E	17.91'
L13	S 60°24'13" W	5.86'
L14	N 16°32'02" W	18.96'

LINE	BEARING	DISTANCE
L1	S 21°24'56" E	20.00'
L2	N 21°34'56" W	20.00'
L3	N 60°21'17" E	10.00'
L4	S 22°05'03" E	20.00'
L5	S 60°21'17" W	10.00'
L6	N 22°05'03" W	20.00'
L7	S 69°49'10" W	10.00'
L8	N 20°10'28" W	85.39'
L9	N 60°21'17" E	10.14'
L10	S 20°10'28" E	87.06'
L11	N 70°36'27" E	4.00'
L12	S 22°05'03" E	17.91'
L13	S 60°21'17" W	5.87'
L14	N 16°34'58" W	18.96'

- ① FRESIDE PARTNERS, LLC CALLED 9,608 SQ. FT. SPECIAL WARRANTY DEED DOC. NO. 201615534 O.P.R.
- ② FRESIDE PARTNERS, LLC CALLED 4,410 SQ. FT. SPECIAL WARRANTY DEED DOC. NO. 201615534 O.P.R.
- ③ FRESIDE PARTNERS, LLC CALLED 2,776 SQ. FT. SPECIAL WARRANTY DEED DOC. NO. 201615534 O.P.R.
- ④ FRESIDE PARTNERS, LLC CALLED 4,492 SQ. FT. SPECIAL WARRANTY DEED DOC. NO. 201615534 O.P.R.
- ⑤ FRESIDE PARTNERS, LLC CALLED 198 SQ. FT. DEED WITHOUT WARRANTY DEED NO. 202016755 O.P.R.
- ⑥ FRESIDE PARTNERS, LLC CALLED 90 SQ. FT. QUITCLAIM DEED DOC. NO. 202016754 O.P.R.
- FRESIDE PARTNERS, LLC CALLED 862 SQ. FT. QUITCLAIM DEED DOC. NO. 201815800 O.P.R.

1. BEARINGS SHOWN HEREON ARE BASED ON THE TEXAS STATE PLANE COORDINATE SYSTEM OF 1983, CENTRAL ZONE (4203).
2. DISTANCES SHOWN HEREON ARE GRID VALUES.
3. FIELD SURVEY COMPLETED 02-08-2023.
4. VISIBLE IMPROVEMENTS/UTILITIES WERE LOCATED WITH THIS SURVEY; UNDERGROUND UTILITIES MAY EXIST WHICH ARE NOT SHOWN HEREON.
5. ACCORDING TO MAP NOS. 484510480E AND 484510485E OF THE FEDERAL EMERGENCY MANAGEMENT AGENCY'S FLOOD INSURANCE RATE MAPS FOR TOM GREEN COUNTY, TEXAS, HAVING AN EFFECTIVE DATE OF JUNE 19, 2012, THE SUBJECT TRACT IS SITUATED WITHIN ZONE X; DEFINED AS AREAS DETERMINED TO BE OUTSIDE THE 0.2% ANNUAL CHANCE FLOODPLAIN. THIS FLOOD STATEMENT SHALL NOT CREATE LIABILITY ON THE PART OF THE SURVEYOR.
6. DETERMINATION OF THE OWNERSHIP, LOCATION, OR DEVELOPMENT OF MINERALS RELATED TO THE SUBJECT TRACT FALL OUTSIDE THE SCOPE OF THIS SURVEY.
7. FIELD NOTE DESCRIPTIONS OF EQUAL DATE WAS PREPARED IN CONJUNCTION WITH THIS SURVEY.

ISSUED BY: TITLE RESOURCES GUARANTY COMPANY  
 COUNTERSIGNED BY: INDEPENDENCE TITLE  
 GE NO: 2253464-COM  
 EFFECTIVE DATE: JANUARY 13, 2023  
 ISSUE DATE: JANUARY 20, 2023  
 REFERENCES:  
 •(10.1) VOL. 460, PG. 64 D.R. (SHOWN HEREON)

STATE OF TEXAS §  
 COUNTY OF KERR §

I HEREBY CERTIFY THAT THIS SURVEY WAS MADE ON THE GROUND, UNDER MY SUPERVISION, THIS 15th DAY OF FEBRUARY, 2023, THAT THIS PLAT CORRECTLY REPRESENTS THE FACTS FOUND AT THE TIME OF THIS SURVEY AND THAT THERE ARE NO VISIBLE EASEMENTS OR ENCROACHMENTS OF BUILDINGS ON ADJOINING PROPERTY AND THAT ALL BUILDINGS ARE WHOLLY LOCATED ON THIS PROPERTY EXCEPT AS SHOWN ABOVE.

JEFF BOERNER, RPLS  
 # 4939  
 TEXAS REGISTRATION NO.

TRACT ONE: A 0.221 ACRE (9,606 SQUARE FEET) TRACT OUT OF LOTS 6 AND 9, BLOCK 43, MAIN PART OF THE CITY OF SAN ANGELO, TOM GREEN COUNTY, TEXAS AS CONVEYED TO FRESIDE PARTNERS, LLC BY SPECIAL WARRANTY DEED RECORDED IN DOCUMENT NO. 201615534, OFFICIAL PUBLIC RECORDS OF TOM GREEN COUNTY, TEXAS.

TRACT TWO: A 0.101 ACRE (4,412 SQUARE FEET) TRACT OUT OF LOT 7, BLOCK 43, MAIN PART OF THE CITY OF SAN ANGELO, TOM GREEN COUNTY, TEXAS AS CONVEYED TO FRESIDE PARTNERS, LLC BY SPECIAL WARRANTY DEED RECORDED IN DOCUMENT NO. 201615534, OFFICIAL PUBLIC RECORDS OF TOM GREEN COUNTY, TEXAS.

TRACT THREE: A 0.064 ACRE (2,772 SQUARE FEET) TRACT OUT OF ACRES LOTS 6 AND 7, MILES ADDITION, CITY OF SAN ANGELO, TOM GREEN COUNTY, TEXAS AS CONVEYED TO FRESIDE PARTNERS, LLC BY SPECIAL WARRANTY DEED RECORDED IN DOCUMENT NO. 201615534, OFFICIAL PUBLIC RECORDS OF TOM GREEN COUNTY, TEXAS.

TRACT FOUR: A 0.104 ACRE (4,517 SQUARE FEET) TRACT OUT OF ACRES LOTS 6 AND 7, MILES ADDITION, CITY OF SAN ANGELO, TOM GREEN COUNTY, TEXAS AS CONVEYED TO FRESIDE PARTNERS, LLC BY SPECIAL WARRANTY DEED RECORDED IN DOCUMENT NO. 201615534, OFFICIAL PUBLIC RECORDS OF TOM GREEN COUNTY, TEXAS.

TRACT FIVE: A 0.005 ACRE (198 SQUARE FEET) TRACT OUT OF ACRES LOTS 6 AND 7, MILES ADDITION, CITY OF SAN ANGELO, TOM GREEN COUNTY, TEXAS AS CONVEYED TO FRESIDE PARTNERS, LLC BY DEED WITHOUT WARRANTY RECORDED IN DOCUMENT NO. 202016755, OFFICIAL PUBLIC RECORDS OF TOM GREEN COUNTY, TEXAS.

TRACT SIX: A 0.002 ACRE (90 SQUARE FEET) TRACT OF ABANDONED STREET RIGHT-OF-WAY AS CONVEYED TO FRESIDE PARTNERS, LLC BY QUITCLAIM DEED RECORDED IN DOCUMENT NO. 202016754, OFFICIAL PUBLIC RECORDS OF TOM GREEN COUNTY, TEXAS.

TRACT SEVEN: A 0.020 ACRE (860 SQUARE FEET) TRACT BEING THE EAST 10' OF THE EAST 30' OF LOT 8, BLOCK 43, MAIN PART OF THE CITY OF SAN ANGELO, TOM GREEN COUNTY, TEXAS AS CONVEYED TO FRESIDE PARTNERS, LLC BY QUITCLAIM DEED RECORDED IN DOCUMENT NO. 201815800, OFFICIAL PUBLIC RECORDS OF TOM GREEN COUNTY, TEXAS.

LAND TITLE SURVEY OF THE FRESIDE PARTNERS, LLC TRACTS BEING A COMBINED 0.517 ACRE OUT OF THE CHRISTIAN SALINGER SURVEY NO. 322, A-1848 JOHN BRAUN SURVEY NO. 323, A-60 TOM GREEN COUNTY, TEXAS FEBRUARY 2023

MDS LAND SURVEYING COMPANY, INC.  
 ALTA | BOUNDARY | CONSTRUCTION | OIL & GAS | TOPOGRAPHIC  
 TEXAS BOARD OF PROFESSIONAL LAND SURVEYING FIRM REGISTRATION NO. 10019600  
 874 HARPER ROAD, SUITE 104 • KERRVILLE, TX 78028 • 830-816-1818  
 JOB No. 23-038-00 SURVEYORS: JB/LK SHEET 1 OF 1

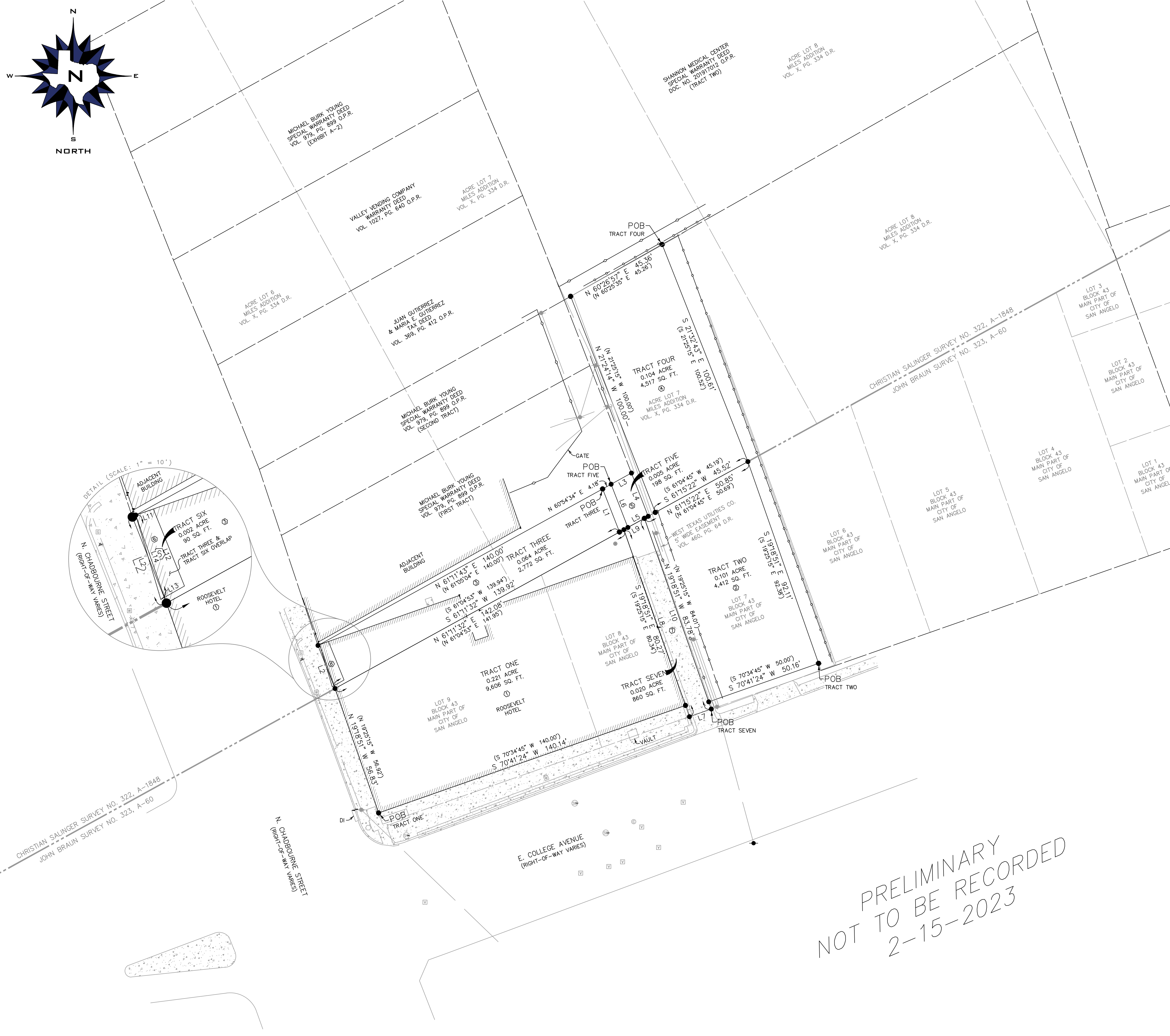

PRELIMINARY  
 NOT TO BE RECORDED  
 2-15-2023



Revisions

**ROOSEVELT LOFTS**

50 N CHADBOURNE STREET  
SAN ANGELO, TX 76903

sheet

**C3.0**

Civil  
DEMOLITION PLAN

permit  
16 JANUARY 2024

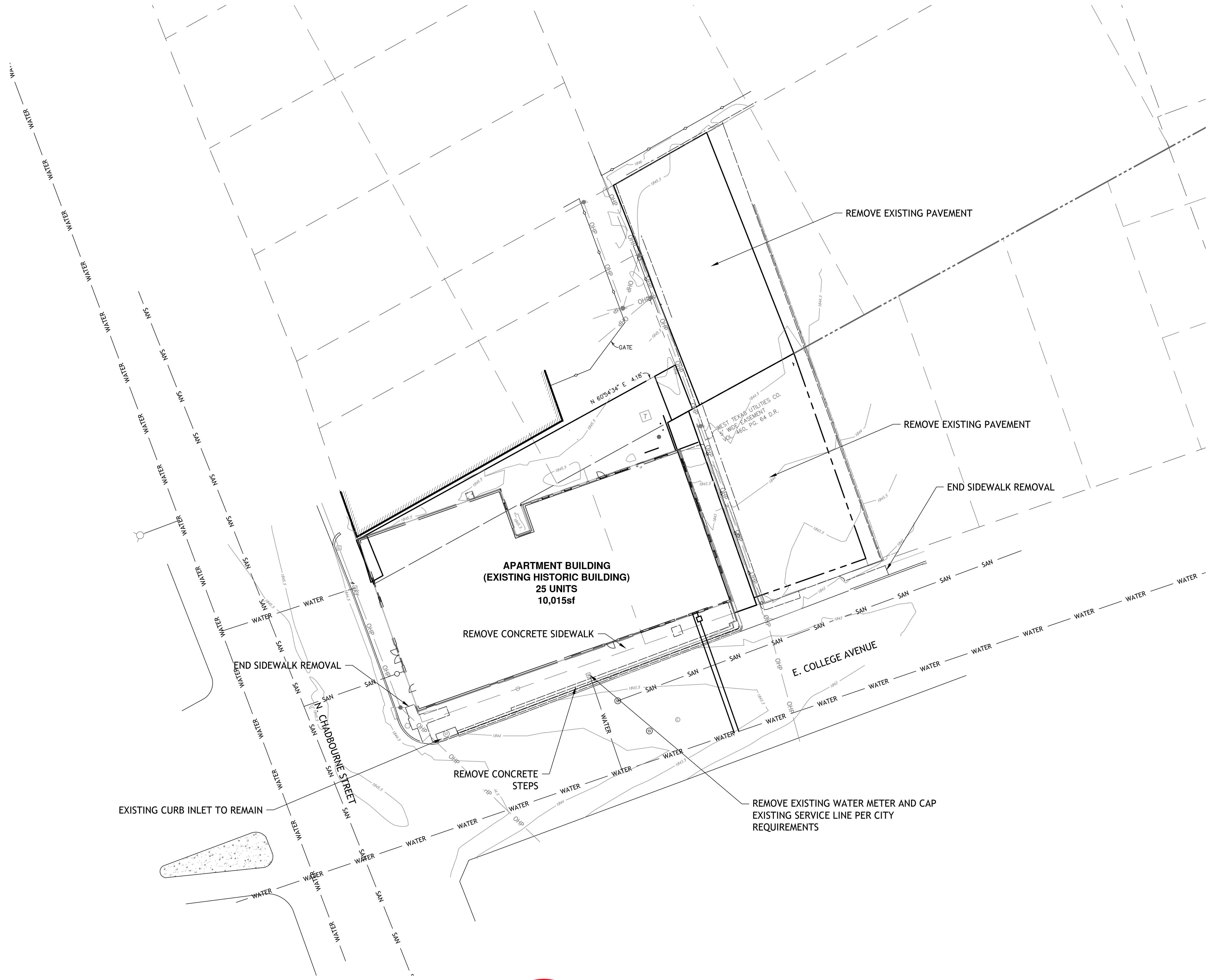

EN23-50000066  
2/2/2024

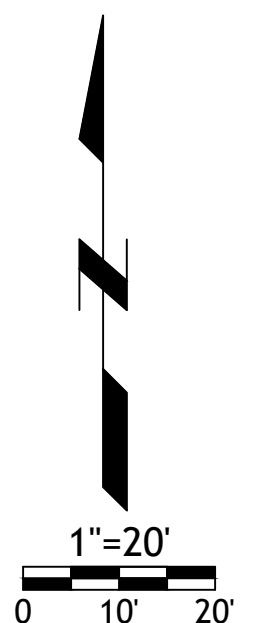



Revisions

**CONSTRUCTION NOTES:**

1. COORDINATE START-UP AND ALL CONSTRUCTION ACTIVITIES WITH OWNER.
2. CONSTRUCTION METHODS AND MATERIALS NOT SPECIFIED IN THESE PLANS ARE TO MEET OR EXCEED THE STANDARD SPECIFICATIONS.
3. ALL CONSTRUCTION WORK AND UTILITY WORK OUTSIDE OF PROPERTY BOUNDARIES SHALL BE PERFORMED IN COOPERATION WITH AND IN ACCORDANCE WITH REGULATIONS OF THE AUTHORITIES CONCERNED.
4. PUBLIC CONVENIENCE AND SAFETY: THE CONTRACTOR SHALL CONDUCT THE WORK IN A MANNER THAT WILL INSURE, AS FAR AS PRACTICABLE, THE LEAST OBSTRUCTION TO TRAFFIC, AND SHALL PROVIDE FOR THE CONVENIENCE AND SAFETY OF THE GENERAL PUBLIC AND RESIDENTS ALONG AND ADJACENT TO HIGHWAYS IN THE CONSTRUCTION AREA.
5. ALL DIMENSIONS SHOWN ARE TO THE BACK OF CURB UNLESS OTHERWISE NOTED.
6. ACCESSIBLE STALLS SHOWN WITH A "VAN" SHALL BE 16'-0" MIN. AND SHALL HAVE A SIGN DESIGNATING "VAN-ACCESSIBLE". SEE DETAIL.
7. ALL TRAFFIC CONTROL DEVICES, INSTALLATION AND OPERATIONS SHALL CONFORM WITH THE "MANUAL ON UNIFORM TRAFFIC CONTROL DEVICES".

**NOTE:**

1. CONTRACTOR SHALL REFER TO ARCHITECTURAL PLANS FOR EXACT LOCATIONS AND DIMENSIONS OF ENTRANCE, SLOPED PAVING, EXIT PORCHES, RAMPS, TRUCK DOCKS. PRECISE BUILDING DIMENSIONS AND EXACT BUILDING UTILITY ENTRANCE LOCATIONS.
2. THESE PLANS HAVE NOT BEEN VERIFIED WITH FINAL ARCHITECTURAL CONTRACT DRAWINGS. CONTRACTOR SHALL VERIFY AND NOTIFY THE ENGINEER OF ANY DISCREPANCIES. CONTRACTOR IS FULLY RESPONSIBLE FOR REVIEW AND COORDINATION OF ALL DRAWINGS AND CONTRACTOR DOCUMENTS.
3. ALL DIMENSIONS ARE TO BACK OF CURB UNLESS NOTED OTHERWISE
4. ALL DIMENSIONS ARE PERPENDICULAR TO PROPERTY LINE.
5. ACTUAL SIGN LOCATIONS TO BE COORDINATED WITH CONSTRUCTION MANAGER.
6. SEE ELECTRICAL PLAN FOR LOCATION OF PARKING LOT LIGHTS.

**ROOSEVELT LOFTS**

50 N CHADBOURNE STREET  
SAN ANGELO, TX 76903

COSA ES  
ARC # S-1849

s h e e t

**C4.0**

Civil  
SITE PLAN  
permit  
16 JANUARY 2024

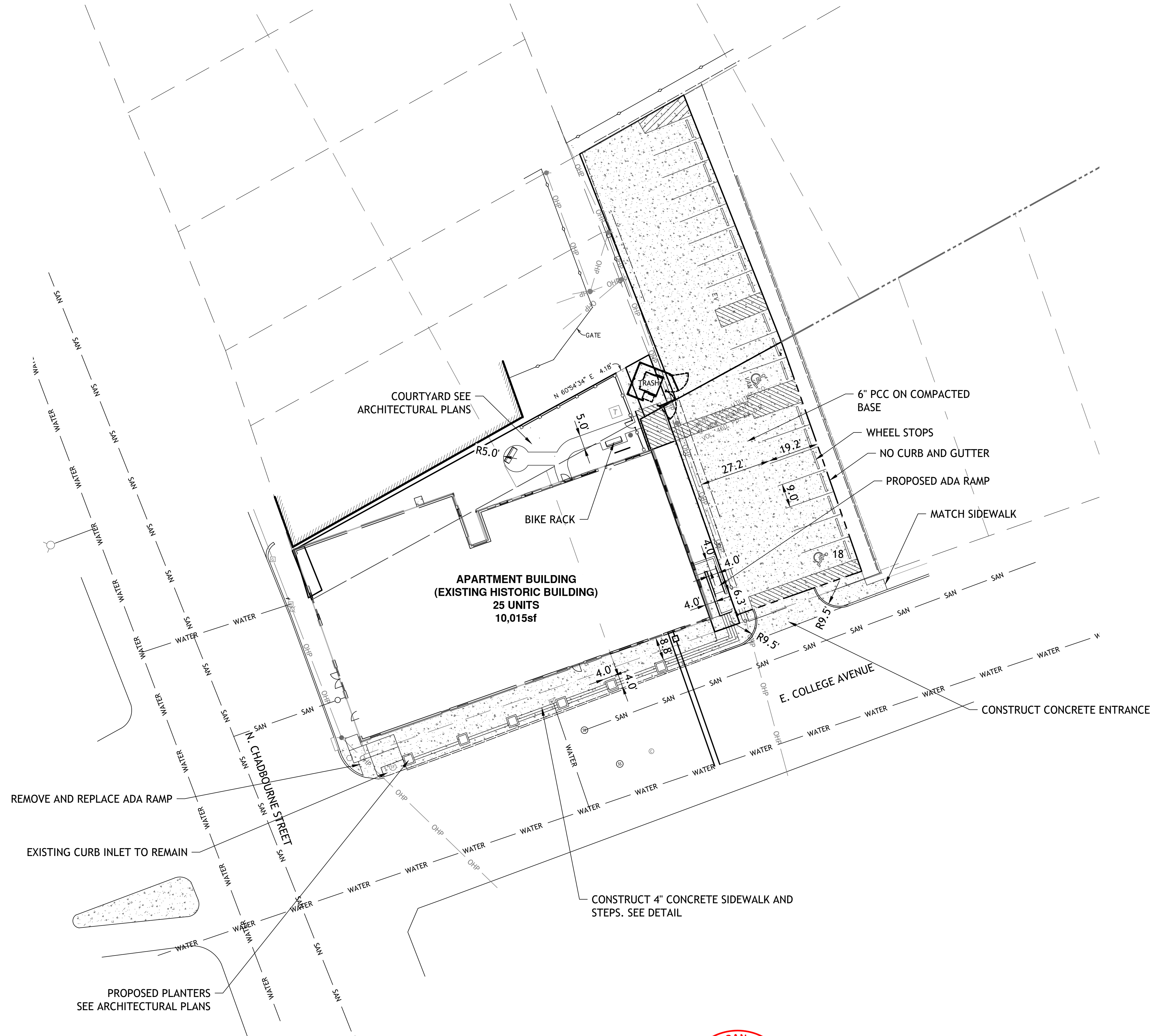

CITY OF SAN ANGELO  
DEPARTMENT OF PUBLIC WORKS

- ACCEPTED
- ACCEPTED AS NOTED

Drawing as to design only. Dimensions and location are not verified, contractor to verify as to plans and/or installation requirements.

*[Signature]* DATE 2/2/2024

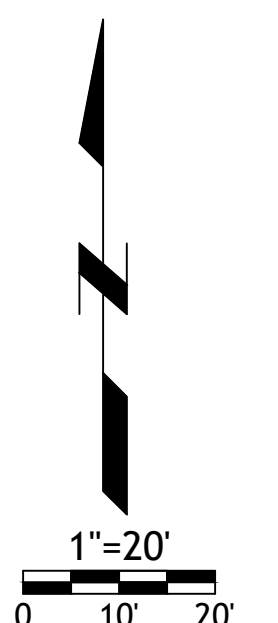

EN23-50000066  
2/2/2024

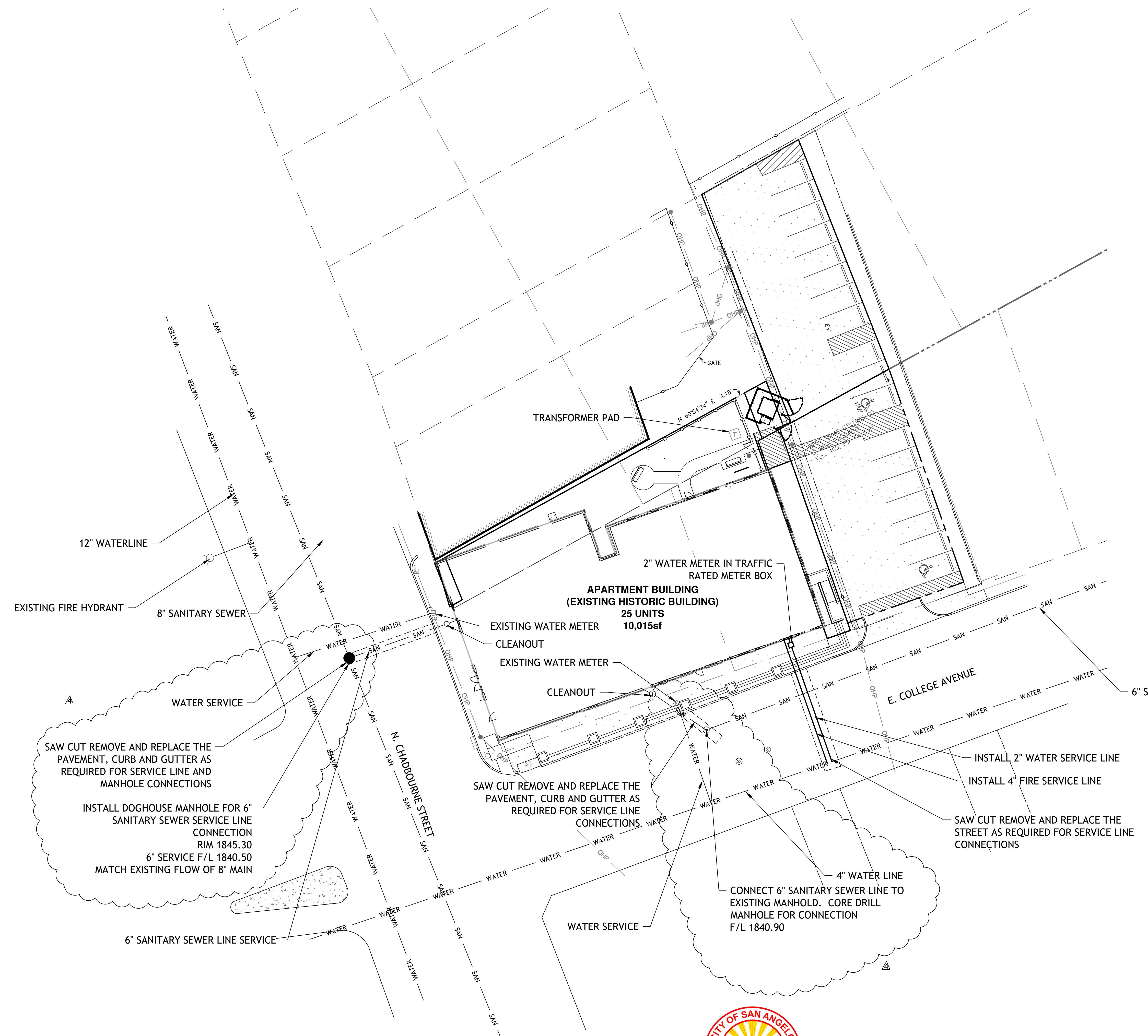

- UTILITY NOTES:**
- CONSTRUCTION SHALL NOT START ON ANY PUBLIC WATER OR SANITARY SEWER SYSTEM UNTIL WRITTEN APPROVAL OR PERMITS HAVE BEEN RECEIVED FROM THE ENGINEER.
  - ALL UTILITY AND STORM SEWER TRENCHES CONSTRUCTED UNDER AREAS THAT RECEIVE PAVING SHALL BE BACKFILLED TO 18 INCHES ABOVE THE TOP OF THE PIPE WITH SELECT GRANULAR MATERIAL PLACED ON EIGHT-INCH LIFTS, AND COMPACTED TO 95% MODIFIED PROCTOR DENSITY.
  - CONTRACTOR SHALL NOT OPEN, TURN OFF, INTERFERE WITH, OR ATTACH ANY PIPE OR HOSE TO OR TAP ANY WATER MAIN BELONGING TO THE CITY UNLESS DULY AUTHORIZED TO DO SO BY THE CITY. ANY ADVERSE CONSEQUENCE OF ANY SCHEDULED OR UNSCHEDULED DISRUPTIONS OF SERVICE TO THE PUBLIC ARE TO BE THE LIABILITY OF THE CONTRACTOR. SM ENGINEERING AND OWNER ARE TO BE HELD HARMLESS.
  - DISINFECTION AND PRESSURE TESTING OF WATER LINES SHALL BE PERFORMED PER SECTION 820 OF THE CITY OF KERRVILLE CONSTRUCTION STANDARDS. THE CONTRACTOR SHALL FURNISH ALL EQUIPMENT AND SUPPLIES REQUIRED FOR TESTING.
  - ALL WATER AND SANITARY SEWER SYSTEMS THAT ARE TO BE PUBLIC LINES SHALL BE CONSTRUCTED IN ACCORDANCE WITH SPECIFICATIONS PREVIOUSLY APPROVED BY THE CITY OF SAN ANGELO AND THE STATE OF TEXAS AND SHALL BE INSPECTED BY THE CITY. IT IS THE CONTRACTOR'S RESPONSIBILITY TO ASSURE THAT THIS INSPECTION OCCURS.
  - LOCATIONS SHOWN FOR PROPOSED WATER LINES ARE APPROXIMATE. VARIATIONS MAY BE MADE, WITH APPROVAL OF THE ENGINEER, TO AVOID CONFLICTS.
  - CONTRACTOR TO INSTALL TRACING TAPE ALONG ALL NON-METALLIC WATER MAINS AND SERVICE LINES PER SPECIFICATIONS.
  - CONTRACTOR SHALL EXPOSE EXISTING UTILITIES AT LOCATIONS OF POSSIBLE CONFLICT AND POINTS OF CONNECTION PRIOR TO ANY CONSTRUCTION OF NEW UTILITIES.
  - WATER LINES SHALL HAVE A MINIMUM COVER OF 36 INCHES AND A MAXIMUM COVER OF 60". ALL VALVES ON MAINS AND FIRE HYDRANT LEADS SHALL BE WITH VALVE BOX ASSEMBLIES. THE SIZE OF VALVE BOX ASSEMBLY TO BE INSTALLED IS DETERMINED BY THE TYPE AND SIZE OF VALVE. VALVE BOX CAPS SHALL HAVE THE WORD "WATER".
  - A MINIMUM HORIZONTAL DISTANCE OF 10 FEET SHALL BE MAINTAINED BETWEEN PARALLEL WATER AND SANITARY SEWER LINES. WHEN IT IS NECESSARY FOR ANY WATER LINE TO CROSS A SANITARY SEWER LINE, THE SEWER LINE SHALL BE CONSTRUCTED OF DUCTILE IRON PIPE AT LEAST 10 FEET EITHER SIDE OF THE WATER LINE UNLESS THE WATER LINE IS AT LEAST 2 FEET CLEAR DISTANCE ABOVE THE SANITARY SEWER LINE.
  - CONTRACTOR TO PROVIDE 10 GAUGE TRACER WIRE AND TRACER WIRE STATIONS. TRACER WIRE SHALL BE PLACED BELOW PIPE EMBEDMENT. SPLICES ARE TOO BE CONNECTED WITH "COPPERHEAD SNAKEBITE LOCKING CONNECTORS" OR CITY APPROVED EQUAL.

SM Engineering  
**SM E**  
 5507 High Meadow Circle  
 Manhattan Kansas, 66503  
 smcivilengr@gmail.com  
 785.341.9747

SM ENGINEERING  
 TEXAS ENGINEERING FIRM  
 F-21697

Drawings and/or Specifications are original proprietary work and property of the Engineer and intended specifically for this project. Use of items contained herein without consent of the Engineer is prohibited. Drawings illustrate best information available to the Engineer. Field verification of actual elements, conditions, and dimensions is required.



- Revisions
- ▲ 2-20-24 ADDENDUM 1
  - ▲ 2-23-24 ADDENDUM 2
  - ▲ 4-26-24 TRAFFIC CONTROL
  - ▲ 5-7-24 CITY COMMENTS

CITY OF SAN ANGELO  
 DEPARTMENT OF PUBLIC WORKS

ACCEPTED  
 ACCEPTED AS NOTED

Drawing as to design only. Dimensions and location are not verified, contractor to verify as to plans and/or installation requirements.

DATE 5/24/2024

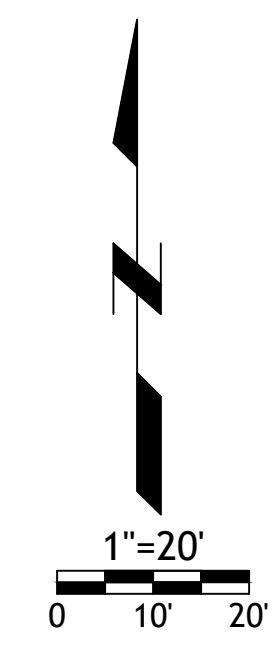

EN23-50000066  
 5/24/2024

**ROOSEVELT LOFTS**  
 50 N CHABOURNE STREET  
 SAN ANGELO, TX 76903

COSA ES  
 ARC # S-1855

**sheet**  
**C5.0**  
 Civil  
 UTILITY PLAN  
 permit  
 16 JANUARY 2024

Revisions

ROOSEVELT LOFTS

50 N CHADBOURNE STREET  
SAN ANGELO, TX 76903

sheet

C6.0

Civil  
GRADING PLAN  
permit  
16 JANUARY 2024

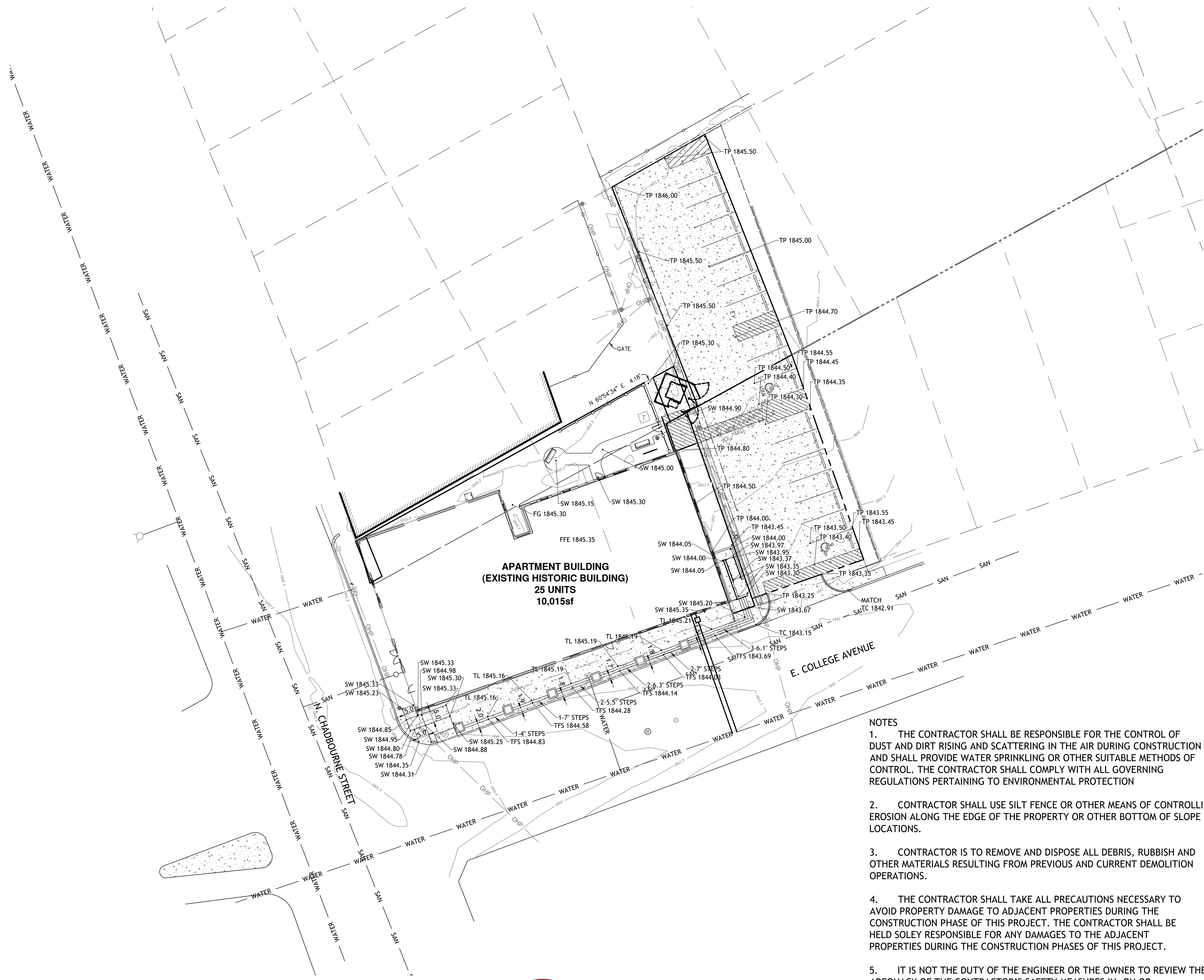

APARTMENT BUILDING  
(EXISTING HISTORIC BUILDING)  
25 UNITS  
10,015sf

NOTES

1. THE CONTRACTOR SHALL BE RESPONSIBLE FOR THE CONTROL OF DUST AND DIRT RISING AND SCATTERING IN THE AIR DURING CONSTRUCTION AND SHALL PROVIDE WATER SPRINKLING OR OTHER SUITABLE METHODS OF CONTROL. THE CONTRACTOR SHALL COMPLY WITH ALL GOVERNING REGULATIONS PERTAINING TO ENVIRONMENTAL PROTECTION
2. CONTRACTOR SHALL USE SILT FENCE OR OTHER MEANS OF CONTROLLING EROSION ALONG THE EDGE OF THE PROPERTY OR OTHER BOTTOM OF SLOPE LOCATIONS.
3. CONTRACTOR IS TO REMOVE AND DISPOSE ALL DEBRIS, RUBBISH AND OTHER MATERIALS RESULTING FROM PREVIOUS AND CURRENT DEMOLITION OPERATIONS.
4. THE CONTRACTOR SHALL TAKE ALL PRECAUTIONS NECESSARY TO AVOID PROPERTY DAMAGE TO ADJACENT PROPERTIES DURING THE CONSTRUCTION PHASE OF THIS PROJECT. THE CONTRACTOR SHALL BE HELD SOLELY RESPONSIBLE FOR ANY DAMAGES TO THE ADJACENT PROPERTIES DURING THE CONSTRUCTION PHASES OF THIS PROJECT.
5. IT IS NOT THE DUTY OF THE ENGINEER OR THE OWNER TO REVIEW THE ADEQUACY OF THE CONTRACTOR'S SAFETY MEASURES IN, ON OR NEAR THE CONSTRUCTION SITE AT ANY TIME DURING CONSTRUCTION
6. HANDICAP STALLS SHALL MEET ADA REQUIREMENTS AND SHALL NOT EXCEED 2% SLOPE IN ANY DIRECTION AT THE BUILDING ENTRY AND ACCESSIBLE STALLS. SLOPES EXCEEDING 2% WILL BE REPLACED AT THE CONTRACTORS EXPENSE.

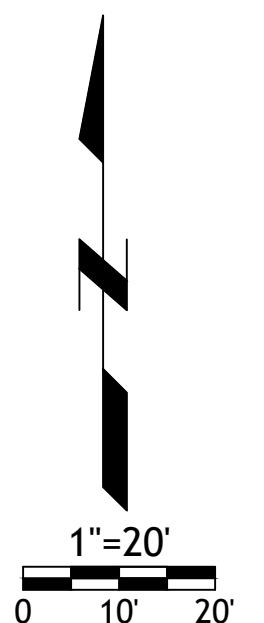

Revisions

ROOSEVELT LOFTS

50 N CHADBOURNE STREET  
SAN ANGELO, TX 76903

COSA ES  
ARC # D-374

sheet

C7.0

Civil  
GRADING PLAN  
permit  
16 JANUARY 2024

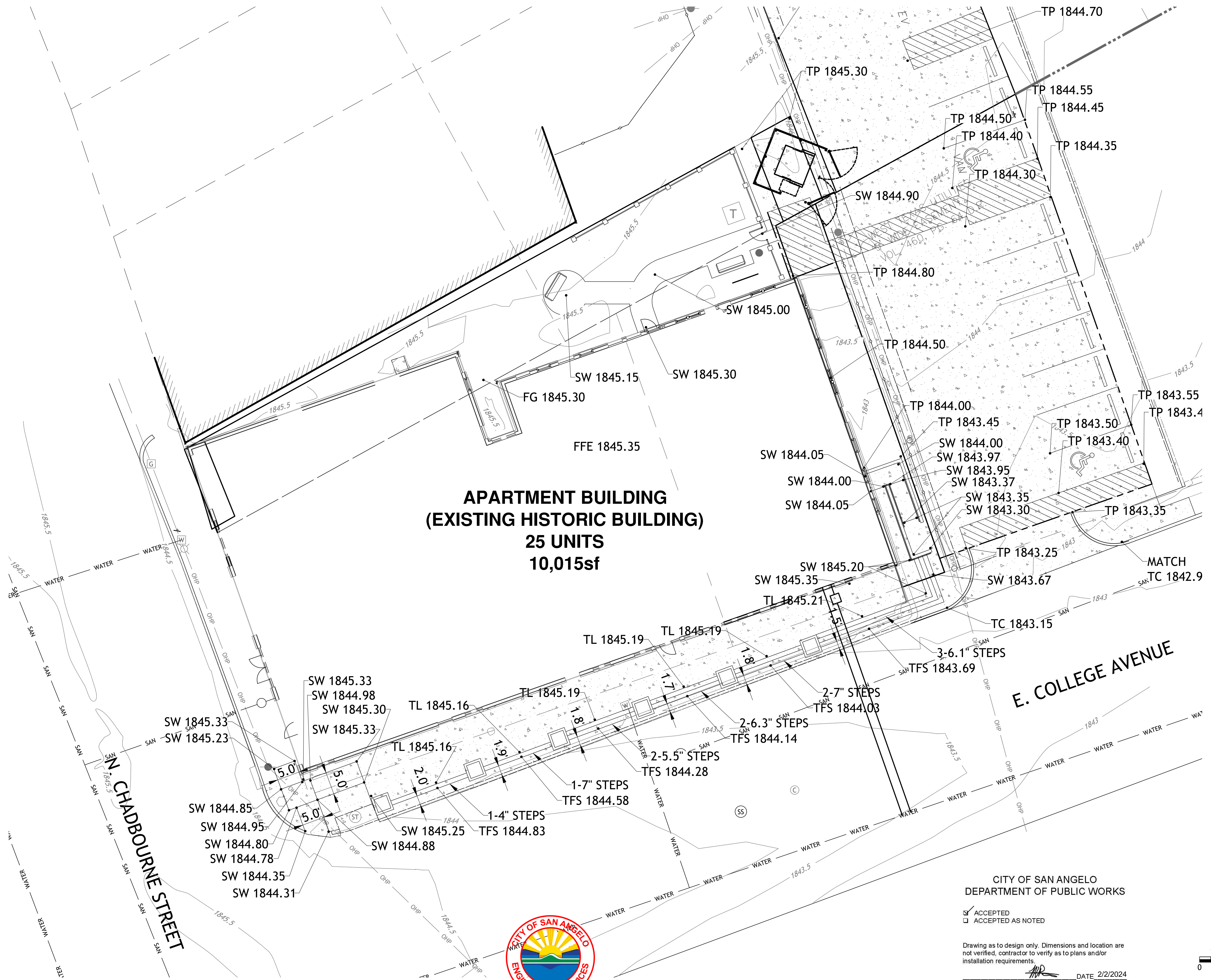

**APARTMENT BUILDING  
(EXISTING HISTORIC BUILDING)  
25 UNITS  
10,015sf**

CITY OF SAN ANGELO  
DEPARTMENT OF PUBLIC WORKS

- ACCEPTED
- ACCEPTED AS NOTED

Drawing as to design only. Dimensions and location are not verified, contractor to verify as to plans and/or installation requirements.

DATE 2/2/2024

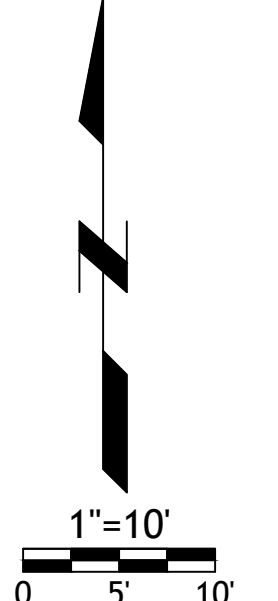

EN23-50000066  
2/2/2024

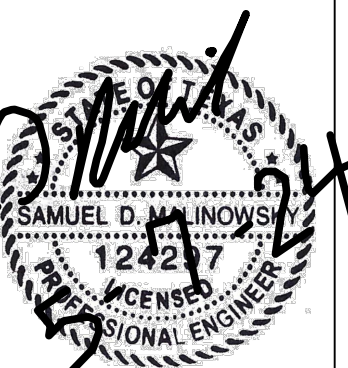

- Revisions
- ▲ 2-20-24 ADDENDUM 1
  - ▲ 2-23-24 ADDENDUM 2
  - ▲ 4-26-24 TRAFFIC CONTROL
  - ▲ 5-7-24 CITY COMMENTS

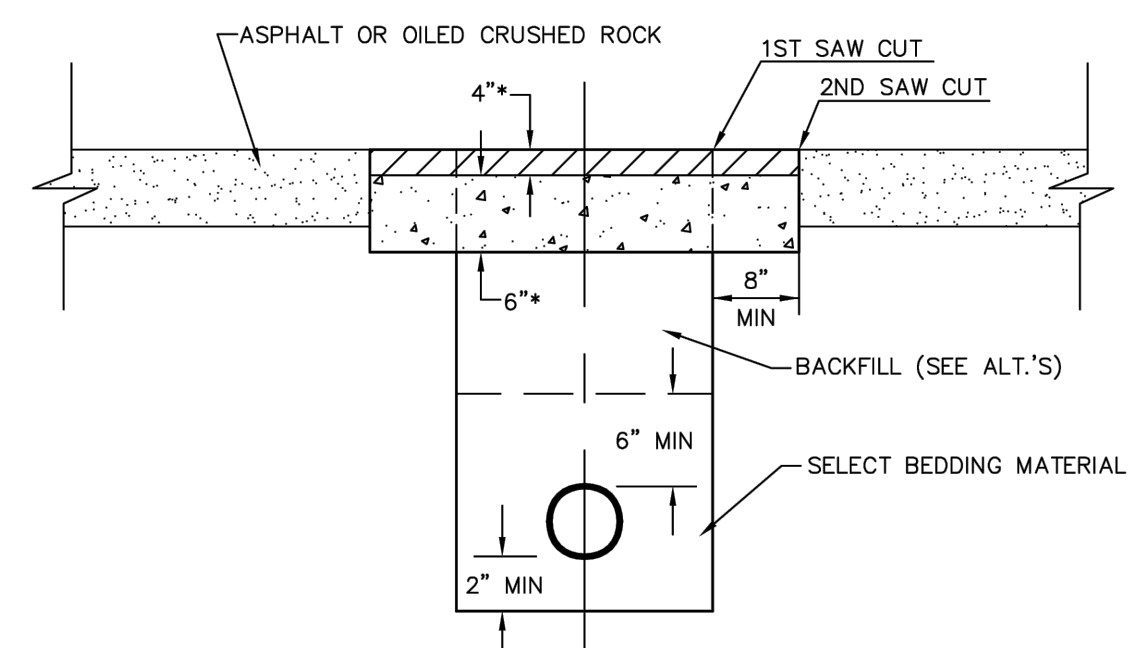

- \* FOR ASPHALT OR OILED CRUSHED ROCK, REPLACE SURFACE WITH 6" CONCRETE BASE AND 4" A.C. SURFACE
- FOR EARTH OR CRUSHED ROCK, REPLACE SURFACE IN KIND: SOIL - 12" DEEP (COMPACTED TO 95%), ROCK - 6" DEEP.
- ALTERNATE BACKFILL METHODS**
    - A. CRUSHER RUN ROCK OR SOIL, FREE OF DEBRIS AND DELETERIOUS MATERIAL MAY BE USED WHEN COMPACTED TO A MINIMUM OF 90% DENSITY. BACKFILL IS SUBJECT TO APPROPRIATE IN-PLACE DENSITY TESTS.
    - B. LEAN MIX CONCRETE FOR BACKFILL MAY BE USED IF VIBRATED TO FILL ALL VOIDS.
    - C. CRUSHED ROCK FOR BACKFILL SHALL CONSIST OF 1 INCH MAXIMUM TO 1/4 MINIMUM CLEAN AGGREGATE, MANIPULATED AND COMPACTED TO ESTABLISH A FIRM INTERLOCK OF PARTICLES.
  - ALL CUTS** ALL CUTS SHALL BE EITHER PLATED OR FILLED WITH COLD MIX AS A TEMPORARY SURFACE IF FINAL SURFACE CANNOT BE INSTALLED.
  - CLEANUP** ALL EXCESS MATERIAL, DEBRIS, MUD, AND OTHER FOREIGN MATTER SHALL BE REMOVED FROM THE STREET RIGHT-OF-WAY IN A MANNER THAT RESTORES THE SURFACE TO ITS ORIGINAL CONDITION.

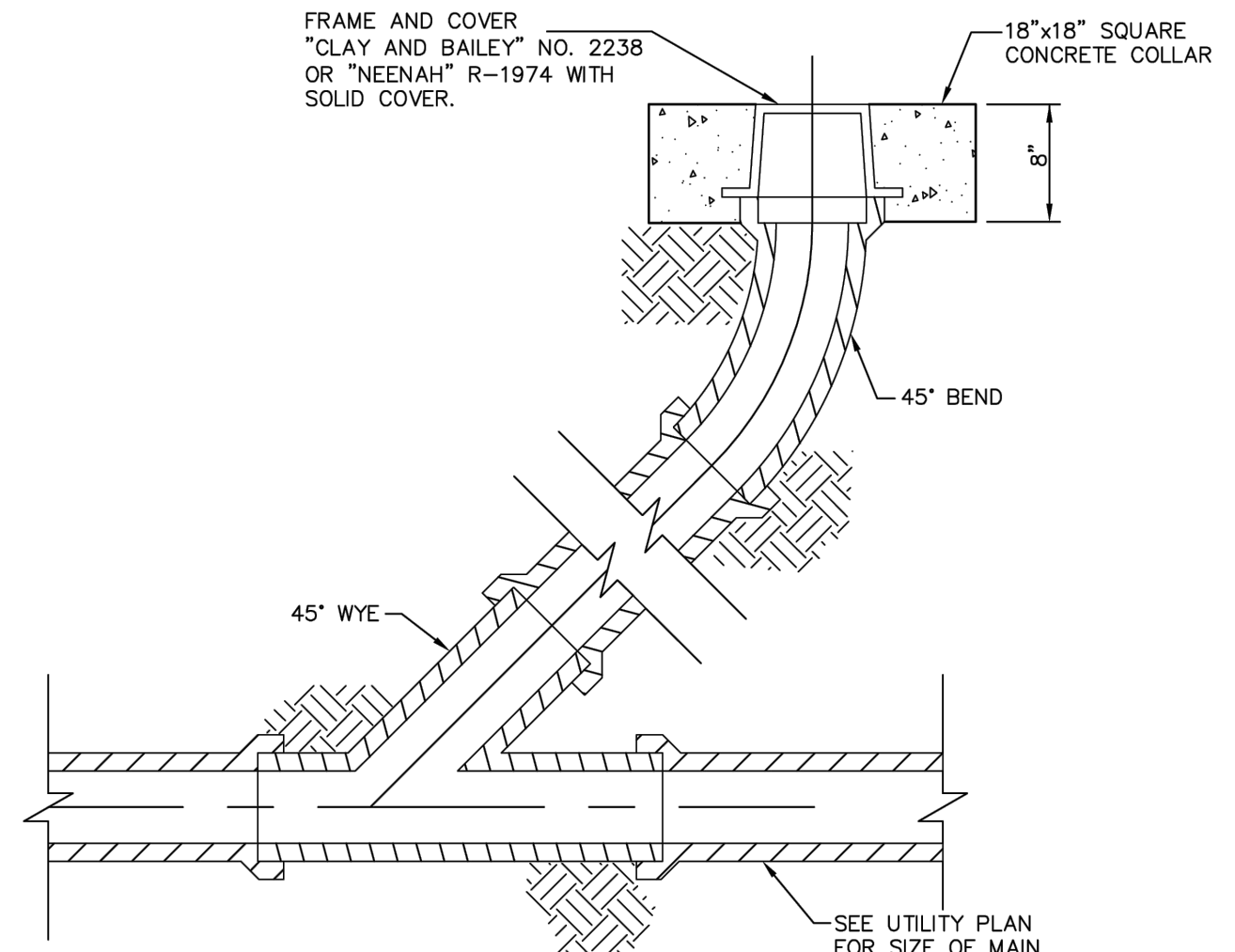

CLEAN-OUT SS2

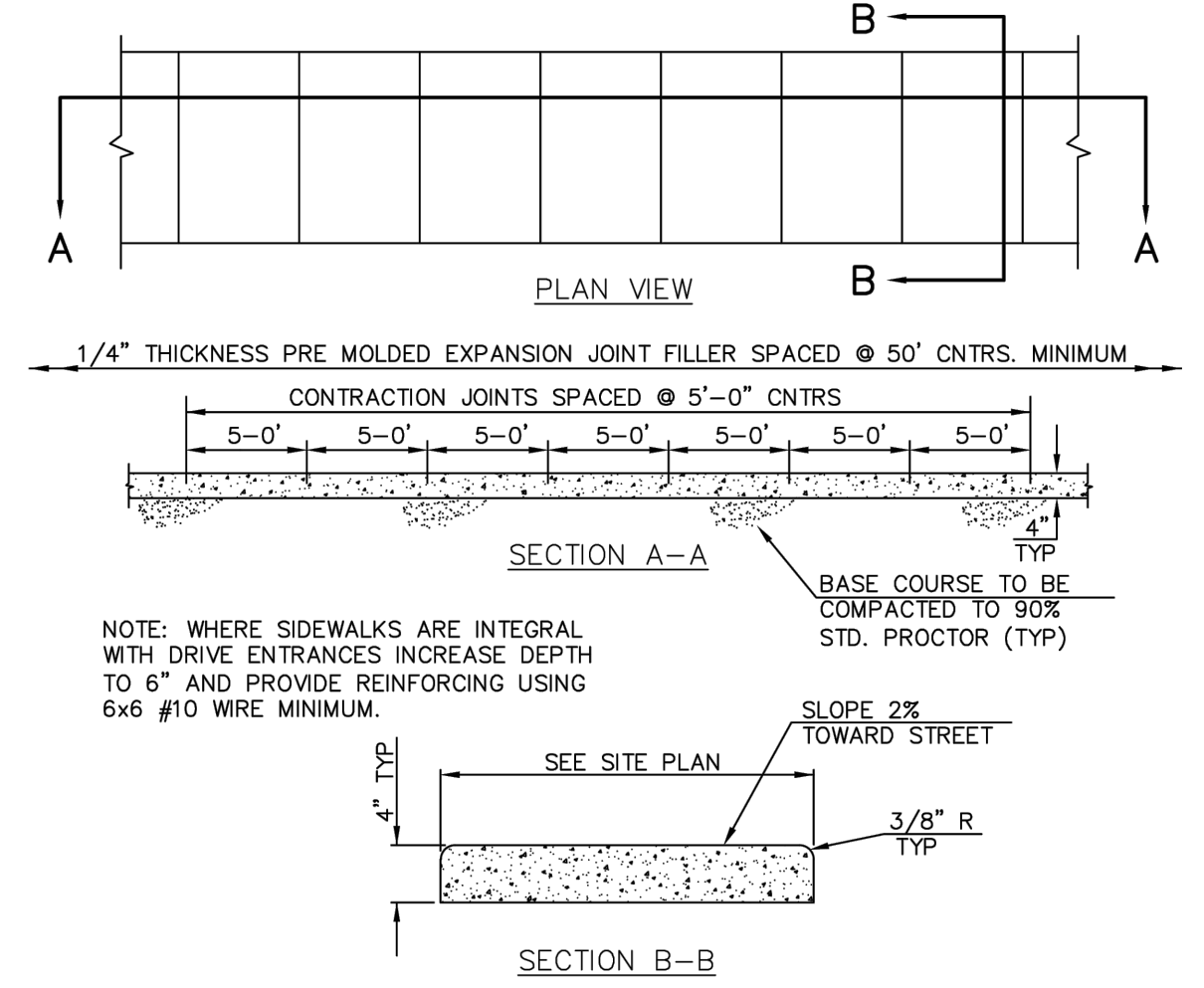

CONCRETE SIDEWALK CW2

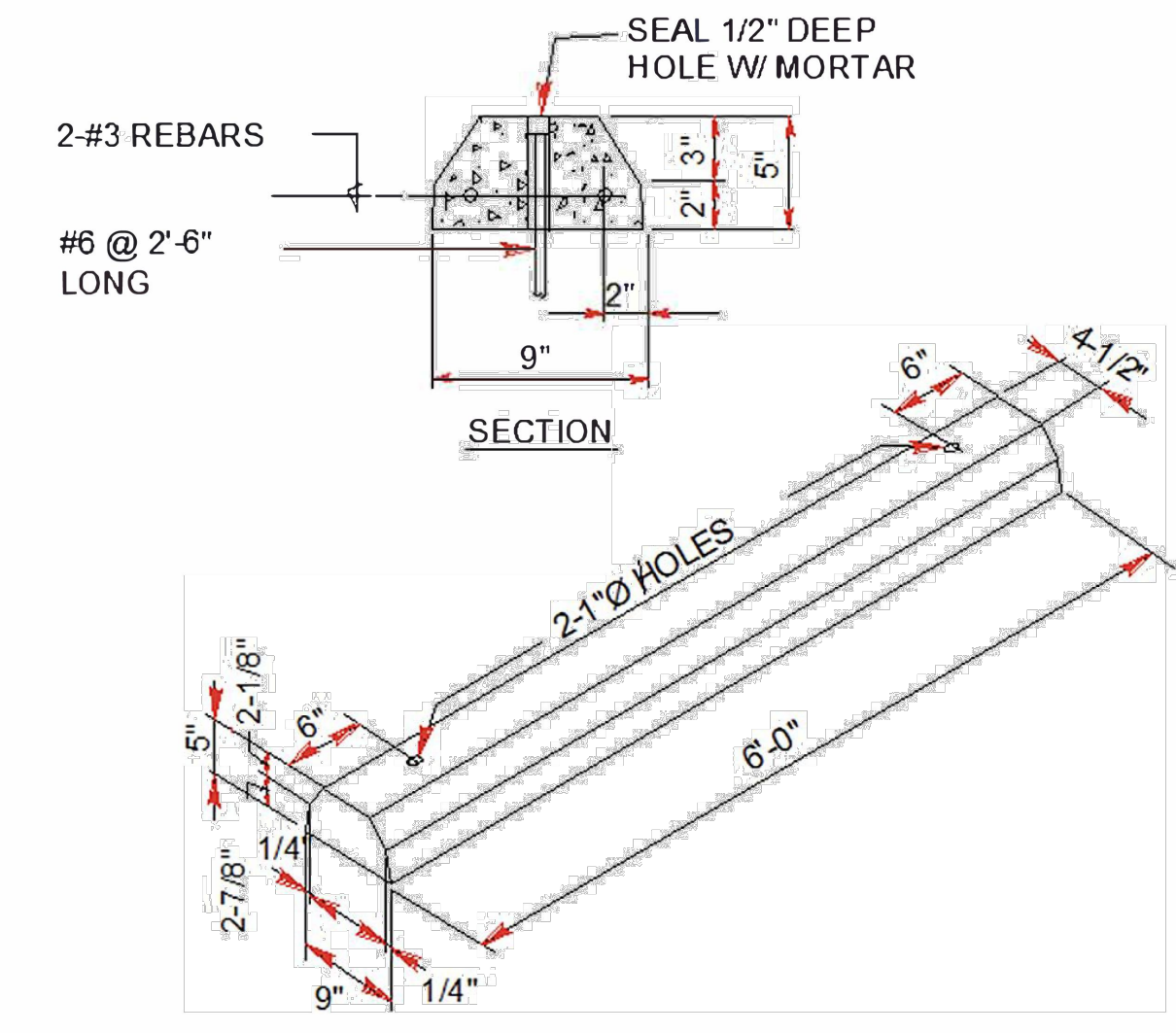

PARKING BLOCK

STREET CUT RESTORATION 030

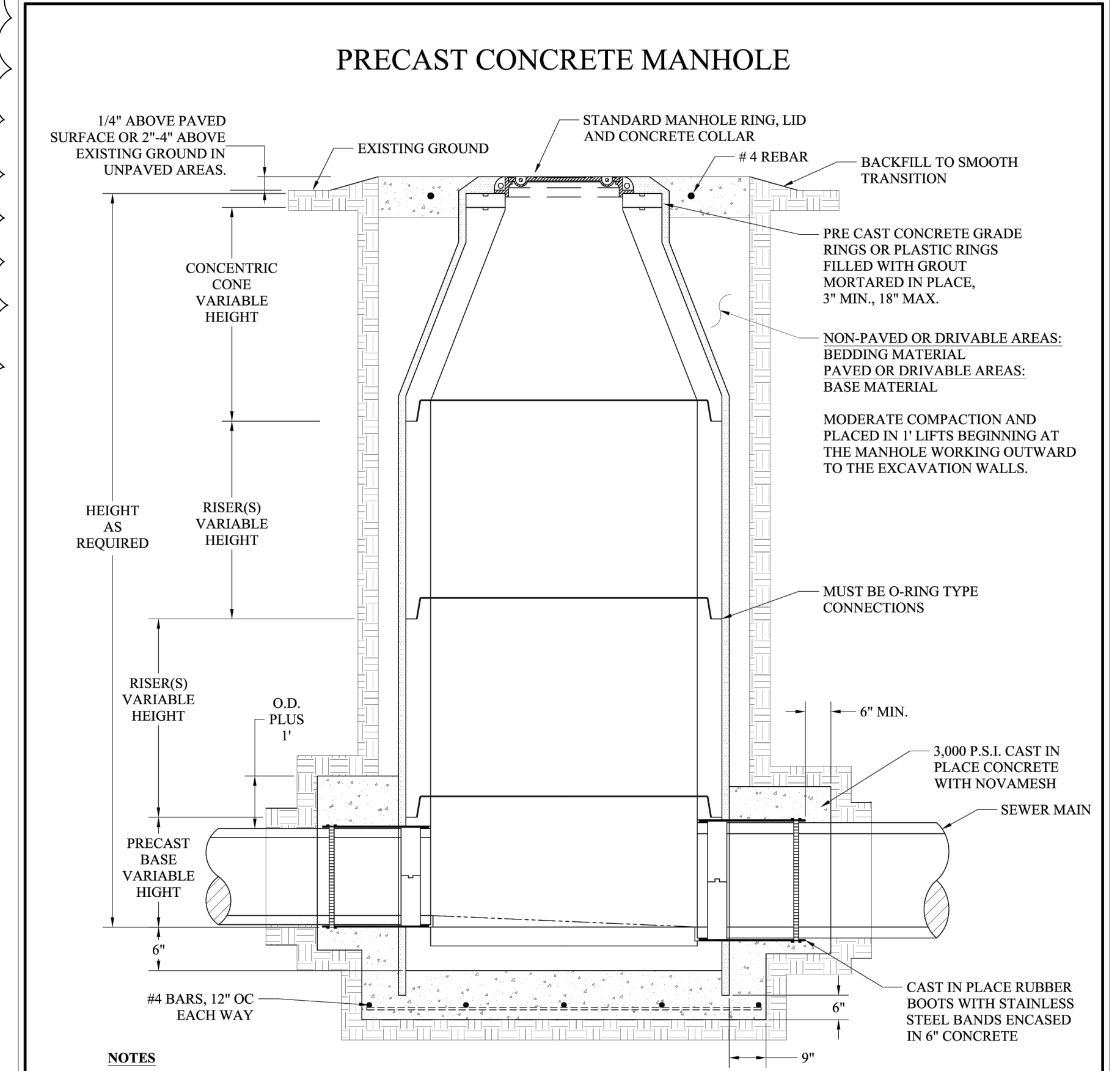

- NOTES**
- MANHOLE SHALL BE CONCENTRIC CONE TYPE PRECAST CONCRETE WITH PRECAST OR POUR IN PLACE CONCRETE BASE.
  - MANHOLE INVERT MAY BE PRECAST OR PLACED IN THE FIELD.
  - THE BASE SHALL BE PLACED ON A GRAVEL FOUNDATION WITH MINIMUM THICKNESS OF 2" FOR LEVELING.
  - LIFTING EYES AND JOINTS SHALL BE GROUTED INSIDE AND OUT.
  - MANHOLES SHALL BE STUBBED OUT WITH SUITABLE SIZE PIPE WHEREVER FUTURE EXTENSION OF THE SEWER IS ANTICIPATED.
  - STUB-OUTS SHALL EXTEND BEYOND THE EDGE OF EXISTING OR PROPOSED PAVING.
  - MANHOLES LOCATED WITHIN A 100-YEAR FLOOD PLAIN OR ANY AREA SUBJECT TO STORMWATER INFILTRATION SHALL INCORPORATE A WATER-TIGHT, BOLT-DOWN RING AND LID AND AN INFLOW PREVENTION DEVICES (IPDs).
  - MANHOLES GREATER THAN 16' DEEP OR SERVING PIPES LARGER THAN 15" SHALL BE 60" DIAMETER AND BE CONSTRUCTED WITH FIBERGLASS OR CONCRETE WITH AN APPROVED PROTECTIVE COATING SYSTEM.

CITY OF SAN ANGELO  
PRECAST CONCRETE MANHOLE  
JUNE 2016 W-SA-MH-CONC

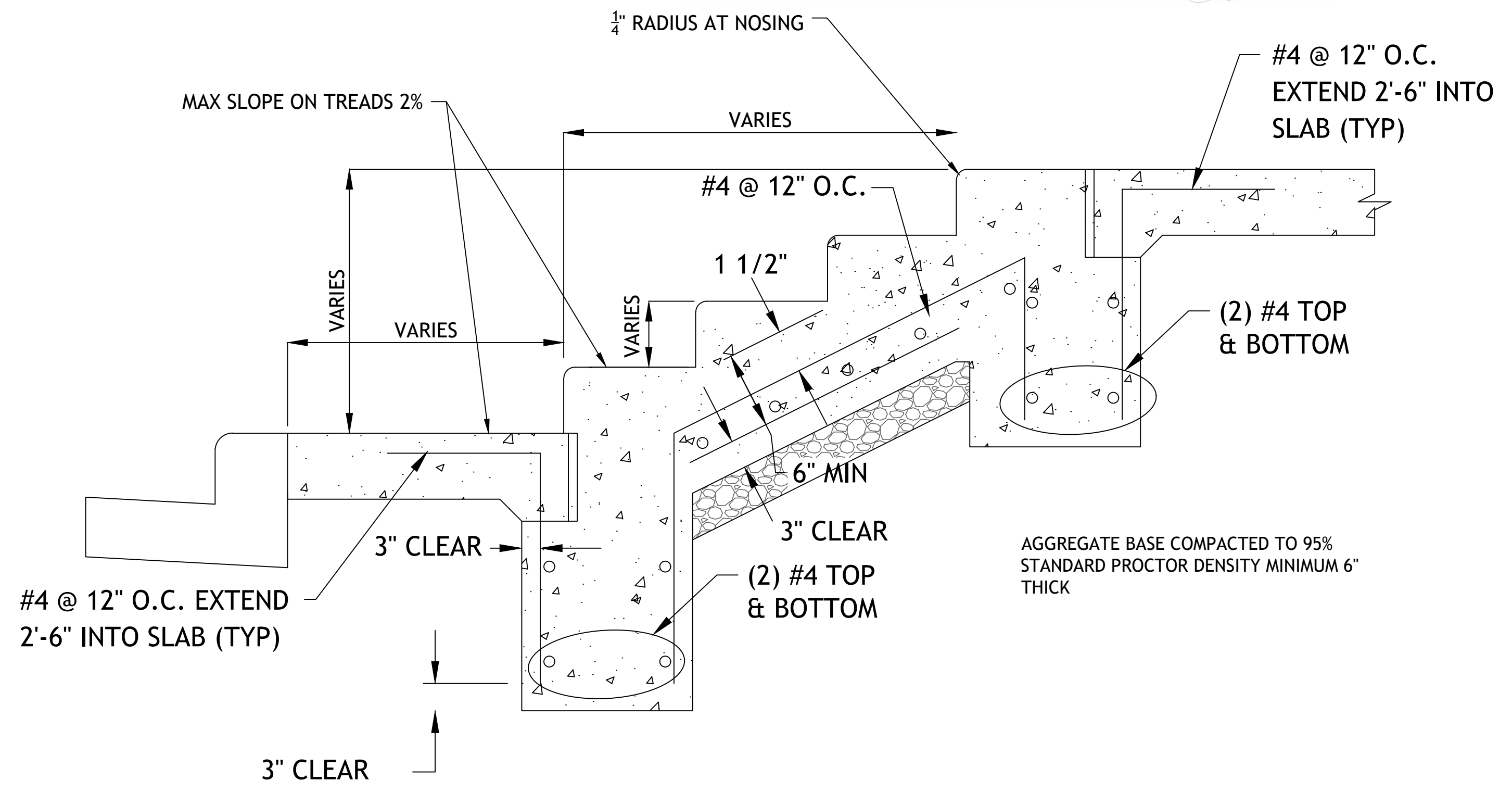

STAIR AND SIDEWALK SECTION

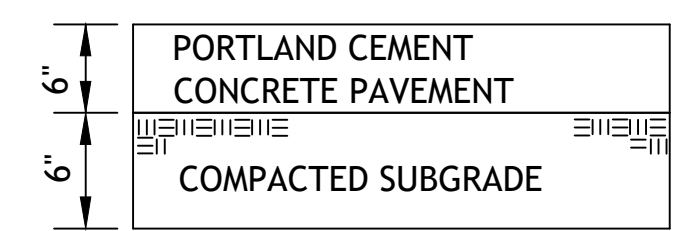

CONCRETE PAVEMENT

- PORTLAND CEMENT CONCRETE SHALL HAVE A MINIMUM COMPRESSIVE STRENGTH OF 4000 PSI AT 28 DAYS WITH 6% ENTRAINED AIR ±2% AND SHALL MEET OR EXCEED THE SPECIFICATIONS SET FORTH IN THE LATEST EDITION OF THE TEXAS DEPARTMENT OF TRANSPORTATION STANDARD SPECIFICATIONS.

CITY OF SAN ANGELO  
DEPARTMENT OF PUBLIC WORKS

ACCEPTED  
ACCEPTED AS NOTED

Drawing as to design only. Dimensions and location are not verified, contractor to verify as to plans and/or installation requirements.

DATE 5/24/2024

ROOSEVELT LOFTS  
50 N CHADBOURNE STREET  
SAN ANGELO, TX 76903

COSA ES  
ARC #  
M-1035-A

sheet  
C8.0  
Civil  
DETAILS  
permit  
16 JANUARY 2024