



Jones Gillam Renz Architects

Address

730 N 9th St.
Salina, KS 67401

1881 Main St., Suite 301
Kansas City, MO 64108

Contact

jgr@jgrarchitects.com
(785) 827-0386

Web

jgrarchitects.com

Project Manual

for

RESERVES AT GRAND VIEW HEIGHTS

New Apartment Complex

Laramie, Wyoming

July 17, 2024

Project No. 22-3262

RESERVES AT GRAND VIEW HEIGHTS
NEW APARTMENT COMPLEX
LARAMIE, WYOMING

Project No. 22-3262

DATE OF PERMIT DRAWINGS AND SPECIFICATIONS

July 17, 2024

OWNER

GRAND VIEW HEIGHTS PARTNERS, LLC
Patrick Beatty, Partner and Matt Gillam, Partner
254 N. Santa Fe Ave, Suite A, Salina, KS 67401
913 396 6310 Fax 913 396 6312

ARCHITECT

JONES GILLAM RENZ ARCHITECTS, INC
Maggie Gillam, Project Architect
730 N. 9th Street, Salina, KS 67401
785 827 0386

STRUCTURAL ENGINEERS

MCCLURE ENGINEERING CO.
Marcus Himmelberg, P. E.
2001 W. Broadway, Columbia, MO 65203
573-814-1568

MECHANICAL/ELECTRICAL

LST CONSULTING ENGINEERS, INC.
John Lewis Smith, P.E.
4809 Vue Du Lac Pl, Ste 201, Manhattan, KS 66503
785 587 8042 Fax 785 587 8039

CIVIL

SOLTERRA ENGINEERING, INC.
Collin Fossen, P.E.
1482 Commerce Dr, Unit B, Laramie, WY 82070
307-223-3204

Table of Contents

	<u>Page</u>	
GENERAL CONDITIONS OF THE CONTRACT FOR CONSTRUCTION	A201-2017-1 - 40	
SUPPLEMENTARY CONDITIONS OF THE CONTRACT	SC-1 - SC-3	
GEOTECHNICAL REPORT	GT-1 – GT-53	
UL ASSEMBLY & ATTACHMENT DETAILS	UL-1 – UL-58	
LIST OF DRAWINGS	LOD-1	
<u>Division 1 - General Requirements</u>		
Section 01010	General Work Requirements	01010-1 – 01010-4
Section 01019	Special Provisions	01019-1 – 01019-2
Section 01030	Alternates	01030-1
Section 01500	Temporary Facilities	01500-1 – 01500-2
Section 019113	General Commissioning Requirements	019113-1 – 019113-6
<u>Division 2 - Site Work</u>		
Section 02110	Site Clearing	02110-1
Section 02205	Soil Materials	02205-1
Section 02211	Rough Grading	02211-1 – 02211-2
Section 02222	Excavating	02222-1
Section 02223	Backfilling	02223-1 – 02223-2
Section 02225	Trenching	02225-1 – 02225-2
Section 02281	Termite Control	02281-1 – 02281-2
Section 02520	Portland Cement Concrete Paving	02520-1 – 02520-2
Section 02810	Irrigation Systems	02810-1 – 02810-6
Section 02920	Lawns and Grasses	02920-1 – 02920-6
Section 02930	Exterior Plants	02930-1 – 02930-10
<u>Division 3 - Concrete</u>		
Section 03100	Concrete Formwork	03100-1 – 03100-2
Section 03200	Concrete Reinforcement	03200-1 – 03200-2
Section 03300	Cast-In-Place Concrete	03300-1 – 03300-4
Section 035216	Lightweight Insulating Concrete	035216-1 – 035216-2
Section 035413	Gypsum Cement Underlayment	035413-1 – 035413-3
<u>Division 4 - Masonry</u>		
Section 04100	Mortar and Masonry Grout	04100-1 – 04100-2
Section 04300	Unit Masonry System	04300-1 – 04300-4
Section 04700	Manufactured Masonry	04700-1 – 04700-2
Section 04720	Cast Stone	04720-1 – 04720-4
<u>Division 5 - Metals</u>		
Section 05120	Structural Steel	05120-1 – 05120-2
Section 05520	Handrails and Railings	05520-1 – 05520-2
<u>Division 6 - Wood and Plastics</u>		
Section 06100	Rough Carpentry	06100-1 – 06100-8
Section 06112	Framing and Sheathing	06112-1 – 06112-2
Section 06114	Wood Blocking	06114-1
Section 061600	Sheathing (Zip System)	061600-1 – 061600-4
Section 06176	Metal Plate-Connected Wood Trusses	06176-1 – 06176-6
Section 06200	Finish Carpentry	06200-1 – 06200-2
<u>Division 7 - Thermal and Moisture Protection</u>		
Section 07181	Water Repellent Coating	07181-1
Section 07212	Board Insulation	07212-1
Section 07213	Batt & Blown-in Insulation	07213-1 – 07213-2
Section 07311	Asphalt Shingles	07311-1 – 07311-4
Section 07460	Siding	07460-1 – 07460-3
Section 07620	Sheet Metal Flashing and Trim	07620-1 – 07620-2
Section 07900	Joint Sealers	07900-1 – 07900-2

Table of Contents, (Cont'd)**Page****Division 8 - Doors and Windows**

Section 08111	Standard Doors and Frames	08111-1 – 08111-2
Section 08211	Flush Wood Doors	08211-1 – 08211-2
Section 08212	Panel Masonite Door	08212-1 – 08212-2
Section 085313	Vinyl Windows	085313-1 – 085313-4
Section 08710	Door Hardware	08710-1 – 08710-5
Section 08800	Glazing	08800-1 - 08800-2

Division 9 - Finishes

Section 09260	Gypsum Board Systems	09260-1 – 09260-2
Section 09306	Floor and Wall Tile	09306-1 – 09306-2
Section 09650	Resilient Flooring	09650-1 – 09650-2
Section 09680	Carpet – Pad and Tack	09680-1 – 09680-4
Section 09900	Painting	09900-1 – 09900-4

Division 10 - Specialties

Section 10431	Signage	10431-1 – 10431-3
Section 10522	Fire Extinguishers, Cabinets and Accessories	10522-1
Section 10800	Toilet and Bath Accessories	10800-1
Section 10850	Building Specialties	10850-1

Division 11 - Equipment

Section 11451	Residential Appliances	11451-1 – 11451-4
---------------	------------------------	-------------------

Division 12 - Furnishings

Section 12356	Kitchen Casework	12356-1 – 12356-4
Section 12491	Horizontal Louver Blinds	12491-1 – 12491-3

Division 13 – Special Construction

Section 133419	Metal Carport System	133419-1 – 133419-4
----------------	----------------------	---------------------

Division 21 – Fire Suppression

Section 210500	Common Work Results for Fire Suppression	210500-1 – 210500-6
Section 210523	General-Duty Valves for Water-Based Fire-Suppression Piping	210523-1 – 210523-5
Section 210553	Identification for Fire Suppression Piping and Equipment	210553-1 – 210553-2
Section 211300	Fire Suppression Sprinklers	211300-1 – 211300-4

Division 22 – Plumbing

Section 220553	Identification for Plumbing Piping and Equipment	220553-1 – 220553-2
Section 220719	Plumbing Piping Insulation	220719-1 – 220719-3
Section 221005	Plumbing Piping	221005-1 – 221005-11
Section 221006	Plumbing Piping Specialties	221006-1 – 221006-3
Section 223000	Plumbing Equipment	223000-1 – 223000-3
Section 224000	Plumbing Fixtures	224000-1 – 224000-2

Division 23 – Heating, Ventilating, and Air Conditioning

Section 230533	Heat Trace Cable	230533-1 – 230533-3
Section 230593	Testing, Adjusting, and Balancing for HVAC	230593-1 – 230593-4
Section 230713	Duct Insulation	230713-1 – 230713-3
Section 230719	HVAC Piping Insulation	230719-1 – 230719-2
Section 232100	General Requirements for HVAC Piping	232100-1 – 232100-2
Section 232300	Refrigerant Piping	232300-1 – 232300-3
Section 233100	HVAC Ducts and Casings	233100-1 – 233100-3
Section 233300	Air Duct Accessories	233300-1 – 233300-4
Section 233700	Air Outlets and Inlets	233700-1 – 233700-2
Section 234000	HVAC Air Cleaning Devices	234000-1 – 234000-2
Section 237223	Packaged Air-to-Air Energy Recovery Units	237223-1
Section 238115	Packaged Vertical Heat Pump	238115-1 – 238115-2
Section 238126.13	Small-Capacity Split-System Air Conditioners	238126.13-1 – 238126.13-3

Division 26 – Electrical

Section 260519	Low-Voltage Electrical Power Conductors and Cables	260519-1 – 260519-7
Section 260526	Grounding and Bonding for Electrical Systems	260526-1 – 260526-5
Section 260529	Hangers and Supports for Electrical Systems	260529-1 – 260529-2

Table of Contents, (Cont'd)**Page**

Section 260533.13	Conduit for Electrical Systems	260533.13-1 – 260533.13-8
Section 260533.16	Boxes for Electrical Systems	260533.16-1 – 260533.16-4
Section 260553	Identification for Electrical Systems	260553-1 – 260553-5
Section 260583	Wiring Connections	260583-1 – 260583-2
Section 262100	Voltage Electrical Service Entrance	262100-1 – 262100-2
Section 262413	Switchboards	262413-1 – 262413-5
Section 262416	Panelboards	262416-1 – 262416-6
Section 262726	Wiring Devices	262726-1 – 262726-5
Section 262813	Fuses	262813-1 – 262813-2
Section 262816.16	Enclosed Switches	262816.16-1 – 262816.16-3
Section 265100	Interior Lighting	265100-1 – 265100-8
Section 265600	Exterior Lighting	265600-1 – 265600-4
<u>Division 28 – Electronic Safety and Security</u>		
Section 284600	Fire Detection and Alarm	284600-1 – 284600-5



AIA[®] Document A201[™] – 2017

General Conditions of the Contract for Construction

for the following PROJECT:

Reserves at Grand View Heights
New Apartment Complex
JGR Project No. 22-3262

THE OWNER:

Grand View Heights Partners, LLC
Patrick Beatty, Partner and Matt Gillam, Partner
254 N. Santa Fe Ave., Ste A
Salina, KS 67401

THE ARCHITECT:

Jones Gillam Renz Architects, Inc.
Jeffrey S. Gillam, Project Architect
730 N Ninth St.
Salina, KS 67401

TABLE OF ARTICLES

1	GENERAL PROVISIONS
2	OWNER
3	CONTRACTOR
4	ARCHITECT
5	SUBCONTRACTORS
6	CONSTRUCTION BY OWNER OR BY SEPARATE CONTRACTORS
7	CHANGES IN THE WORK
8	TIME
9	PAYMENTS AND COMPLETION
10	PROTECTION OF PERSONS AND PROPERTY
11	INSURANCE AND BONDS
12	UNCOVERING AND CORRECTION OF WORK
13	MISCELLANEOUS PROVISIONS
14	TERMINATION OR SUSPENSION OF THE CONTRACT
15	CLAIMS AND DISPUTES

ADDITIONS AND DELETIONS:

The author of this document has added information needed for its completion. The author may also have revised the text of the original AIA standard form. An *Additions and Deletions Report* that notes added information as well as revisions to the standard form text is available from the author and should be reviewed. A vertical line in the left margin of this document indicates where the author has added necessary information and where the author has added to or deleted from the original AIA text.

This document has important legal consequences. Consultation with an attorney is encouraged with respect to its completion or modification.

For guidance in modifying this document to include supplementary conditions, see AIA Document A503[™], Guide for Supplementary Conditions.

Init.

/

INDEX

(Topics and numbers in bold are Section headings.)

Acceptance of Nonconforming Work

9.6.6, 9.9.3, **12.3**

Acceptance of Work

9.6.6, 9.8.2, 9.9.3, 9.10.1, 9.10.3, 12.3

Access to Work

3.16, 6.2.1, 12.1

Accident Prevention

10

Acts and Omissions

3.2, 3.3.2, 3.12.8, 3.18, 4.2.3, 8.3.1, 9.5.1, 10.2.5,

10.2.8, 13.3.2, 14.1, 15.1.2, 15.2

Addenda

1.1.1

Additional Costs, Claims for

3.7.4, 3.7.5, 10.3.2, 15.1.5

Additional Inspections and Testing

9.4.2, 9.8.3, 12.2.1, **13.4**

Additional Time, Claims for

3.2.4, 3.7.4, 3.7.5, 3.10.2, 8.3.2, **15.1.6**

Administration of the Contract

3.1.3, **4.2**, 9.4, 9.5

Advertisement or Invitation to Bid

1.1.1

Aesthetic Effect

4.2.13

Allowances

3.8

Applications for Payment

4.2.5, 7.3.9, 9.2, **9.3**, 9.4, 9.5.1, 9.5.4, 9.6.3, 9.7, 9.10

Approvals

2.1.1, 2.3.1, 2.5, 3.1.3, 3.10.2, 3.12.8, 3.12.9,

3.12.10.1, 4.2.7, 9.3.2, 13.4.1

Arbitration

8.3.1, 15.3.2, **15.4**

ARCHITECT

4

Architect, Definition of

4.1.1

Architect, Extent of Authority

2.5, 3.12.7, 4.1.2, 4.2, 5.2, 6.3, 7.1.2, 7.3.4, 7.4, 9.2,
9.3.1, 9.4, 9.5, 9.6.3, 9.8, 9.10.1, 9.10.3, 12.1, 12.2.1,
13.4.1, 13.4.2, 14.2.2, 14.2.4, 15.1.4, 15.2.1

Architect, Limitations of Authority and Responsibility

2.1.1, 3.12.4, 3.12.8, 3.12.10, 4.1.2, 4.2.1, 4.2.2, 4.2.3,
4.2.6, 4.2.7, 4.2.10, 4.2.12, 4.2.13, 5.2.1, 7.4, 9.4.2,
9.5.4, 9.6.4, 15.1.4, 15.2

Architect's Additional Services and Expenses

2.5, 12.2.1, 13.4.2, 13.4.3, 14.2.4

Architect's Administration of the Contract

3.1.3, 3.7.4, 15.2, 9.4.1, 9.5

Architect's Approvals

2.5, 3.1.3, 3.5, 3.10.2, 4.2.7

Architect's Authority to Reject Work

3.5, 4.2.6, 12.1.2, 12.2.1

Architect's Copyright

1.1.7, 1.5

Architect's Decisions

3.7.4, 4.2.6, 4.2.7, 4.2.11, 4.2.12, 4.2.13, 4.2.14, 6.3,
7.3.4, 7.3.9, 8.1.3, 8.3.1, 9.2, 9.4.1, 9.5, 9.8.4, 9.9.1,
13.4.2, 15.2

Architect's Inspections

3.7.4, 4.2.2, 4.2.9, 9.4.2, 9.8.3, 9.9.2, 9.10.1, 13.4

Architect's Instructions

3.2.4, 3.3.1, 4.2.6, 4.2.7, 13.4.2

Architect's Interpretations

4.2.11, 4.2.12

Architect's Project Representative

4.2.10

Architect's Relationship with Contractor

1.1.2, 1.5, 2.3.3, 3.1.3, 3.2.2, 3.2.3, 3.2.4, 3.3.1, 3.4.2,
3.5, 3.7.4, 3.7.5, 3.9.2, 3.9.3, 3.10, 3.11, 3.12, 3.16,
3.18, 4.1.2, 4.2, 5.2, 6.2.2, 7, 8.3.1, 9.2, 9.3, 9.4, 9.5,
9.7, 9.8, 9.9, 10.2.6, 10.3, 11.3, 12, 13.3.2, 13.4, 15.2

Architect's Relationship with Subcontractors

1.1.2, 4.2.3, 4.2.4, 4.2.6, 9.6.3, 9.6.4, 11.3

Architect's Representations

9.4.2, 9.5.1, 9.10.1

Architect's Site Visits

3.7.4, 4.2.2, 4.2.9, 9.4.2, 9.5.1, 9.9.2, 9.10.1, 13.4

Asbestos

10.3.1

Attorneys' Fees

3.18.1, 9.6.8, 9.10.2, 10.3.3

Award of Separate Contracts

6.1.1, 6.1.2

Award of Subcontracts and Other Contracts for Portions of the Work

5.2

Basic Definitions

1.1

Bidding Requirements

1.1.1

Binding Dispute Resolution

8.3.1, 9.7, 11.5, 13.1, 15.1.2, 15.1.3, 15.2.1, 15.2.5,
15.2.6.1, 15.3.1, 15.3.2, 15.3.3, 15.4.1

Bonds, Lien

7.3.4.4, 9.6.8, 9.10.2, 9.10.3

Bonds, Performance, and Payment

7.3.4.4, 9.6.7, 9.10.3, **11.1.2**, 11.1.3, **11.5**

Building Information Models Use and Reliance

1.8

Building Permit

3.7.1

Capitalization

1.3

Certificate of Substantial Completion

9.8.3, 9.8.4, 9.8.5

Init.

/

Certificates for Payment

4.2.1, 4.2.5, 4.2.9, 9.3.3, **9.4**, 9.5, 9.6.1, 9.6.6, 9.7, 9.10.1, 9.10.3, 14.1.1.3, 14.2.4, 15.1.4

Certificates of Inspection, Testing or Approval
13.4.4

Certificates of Insurance
9.10.2

Change Orders

1.1.1, 3.4.2, 3.7.4, 3.8.2.3, 3.11, 3.12.8, 4.2.8, 5.2.3, 7.1.2, 7.1.3, **7.2**, 7.3.2, 7.3.7, 7.3.9, 7.3.10, 8.3.1, 9.3.1.1, 9.10.3, 10.3.2, 11.2, 11.5, 12.1.2

Change Orders, Definition of
7.2.1

CHANGES IN THE WORK

2.2.2, 3.11, 4.2.8, 7, 7.2.1, 7.3.1, 7.4, 8.3.1, 9.3.1.1, 11.5

Claims, Definition of

15.1.1

Claims, Notice of
1.6.2, 15.1.3

CLAIMS AND DISPUTES

3.2.4, 6.1.1, 6.3, 7.3.9, 9.3.3, 9.10.4, 10.3.3, **15**, 15.4
Claims and Timely Assertion of Claims
15.4.1

Claims for Additional Cost

3.2.4, 3.3.1, 3.7.4, 7.3.9, 9.5.2, 10.2.5, 10.3.2, **15.1.5**

Claims for Additional Time

3.2.4, 3.3.1, 3.7.4, 6.1.1, 8.3.2, 9.5.2, 10.3.2, **15.1.6**

Concealed or Unknown Conditions, Claims for **3.7.4**

Claims for Damages

3.2.4, 3.18, 8.3.3, 9.5.1, 9.6.7, 10.2.5, 10.3.3, 11.3, 11.3.2, 14.2.4, 15.1.7

Claims Subject to Arbitration
15.4.1

Cleaning Up

3.15, 6.3

Commencement of the Work, Conditions Relating to
2.2.1, 3.2.2, 3.4.1, 3.7.1, 3.10.1, 3.12.6, 5.2.1, 5.2.3, 6.2.2, 8.1.2, 8.2.2, 8.3.1, 11.1, 11.2, **15.1.5**

Commencement of the Work, Definition of
8.1.2

Communications

3.9.1, **4.2.4**

Completion, Conditions Relating to

3.4.1, 3.11, 3.15, 4.2.2, 4.2.9, 8.2, 9.4.2, 9.8, 9.9.1, 9.10, 12.2, 14.1.2, 15.1.2

COMPLETION, PAYMENTS AND **9**

Completion, Substantial

3.10.1, 4.2.9, 8.1.1, 8.1.3, 8.2.3, 9.4.2, 9.8, 9.9.1, 9.10.3, 12.2, 15.1.2

Compliance with Laws

2.3.2, 3.2.3, 3.6, 3.7, 3.12.10, 3.13, 9.6.4, 10.2.2, 13.1, 13.3, 13.4.1, 13.4.2, 13.5, 14.1.1, 14.2.1.3, 15.2.8, 15.4.2, 15.4.3

Concealed or Unknown Conditions

3.7.4, 4.2.8, 8.3.1, 10.3

Conditions of the Contract

1.1.1, 6.1.1, 6.1.4

Consent, Written

3.4.2, 3.14.2, 4.1.2, 9.8.5, 9.9.1, 9.10.2, 9.10.3, 13.2, 15.4.4.2

Consolidation or Joinder

15.4.4

CONSTRUCTION BY OWNER OR BY SEPARATE CONTRACTORS

1.1.4, **6**

Construction Change Directive, Definition of
7.3.1

Construction Change Directives

1.1.1, 3.4.2, 3.11, 3.12.8, 4.2.8, 7.1.1, 7.1.2, 7.1.3, **7.3**, 9.3.1.1

Construction Schedules, Contractor's

3.10, 3.11, 3.12.1, 3.12.2, 6.1.3, 15.1.6.2

Contingent Assignment of Subcontracts

5.4, 14.2.2.2

Continuing Contract Performance

15.1.4

Contract, Definition of

1.1.2

CONTRACT, TERMINATION OR SUSPENSION OF THE

5.4.1.1, 5.4.2, 11.5, **14**

Contract Administration

3.1.3, 4, 9.4, 9.5

Contract Award and Execution, Conditions Relating to

3.7.1, 3.10, 5.2, 6.1

Contract Documents, Copies Furnished and Use of
1.5.2, 2.3.6, 5.3

Contract Documents, Definition of

1.1.1

Contract Sum

2.2.2, 2.2.4, 3.7.4, 3.7.5, 3.8, 3.10.2, 5.2.3, 7.3, 7.4, **9.1**, 9.2, 9.4.2, 9.5.1.4, 9.6.7, 9.7, 10.3.2, 11.5, 12.1.2, 12.3, 14.2.4, 14.3.2, 15.1.4.2, **15.1.5**, **15.2.5**

Contract Sum, Definition of

9.1

Contract Time

1.1.4, 2.2.1, 2.2.2, 3.7.4, 3.7.5, 3.10.2, 5.2.3, 6.1.5, 7.2.1.3, 7.3.1, 7.3.5, 7.3.6, 7, 7, 7.3.10, 7.4, 8.1.1, 8.2.1, 8.2.3, 8.3.1, 9.5.1, 9.7, 10.3.2, 12.1.1, 12.1.2, 14.3.2, 15.1.4.2, 15.1.6.1, 15.2.5

Contract Time, Definition of

8.1.1

CONTRACTOR

3

Contractor, Definition of

3.1, **6.1.2**

Contractor's Construction and Submittal Schedules

3.10, 3.12.1, 3.12.2, 4.2.3, 6.1.3, 15.1.6.2

Init.

/

Contractor's Employees
2.2.4, 3.3.2, 3.4.3, 3.8.1, 3.9, 3.18.2, 4.2.3, 4.2.6, 10.2,
10.3, 11.3, 14.1, 14.2.1.1

Contractor's Liability Insurance
11.1
Contractor's Relationship with Separate Contractors
and Owner's Forces
3.12.5, 3.14.2, 4.2.4, 6, 11.3, 12.2.4

Contractor's Relationship with Subcontractors
1.2.2, 2.2.4, 3.3.2, 3.18.1, 3.18.2, 4.2.4, 5, 9.6.2, 9.6.7,
9.10.2, 11.2, 11.3, 11.4

Contractor's Relationship with the Architect
1.1.2, 1.5, 2.3.3, 3.1.3, 3.2.2, 3.2.3, 3.2.4, 3.3.1, 3.4.2,
3.5.1, 3.7.4, 3.10, 3.11, 3.12, 3.16, 3.18, 4.2, 5.2, 6.2.2,
7, 8.3.1, 9.2, 9.3, 9.4, 9.5, 9.7, 9.8, 9.9, 10.2.6, 10.3,
11.3, 12, 13.4, 15.1.3, 15.2.1

Contractor's Representations
3.2.1, 3.2.2, 3.5, 3.12.6, 6.2.2, 8.2.1, 9.3.3, 9.8.2

Contractor's Responsibility for Those Performing the
Work
3.3.2, 3.18, 5.3, 6.1.3, 6.2, 9.5.1, 10.2.8

Contractor's Review of Contract Documents
3.2

Contractor's Right to Stop the Work
2.2.2, 9.7

Contractor's Right to Terminate the Contract
14.1

Contractor's Submittals
3.10, 3.11, 3.12, 4.2.7, 5.2.1, 5.2.3, 9.2, 9.3, 9.8.2,
9.8.3, 9.9.1, 9.10.2, 9.10.3

Contractor's Superintendent
3.9, 10.2.6

Contractor's Supervision and Construction
Procedures
1.2.2, 3.3, 3.4, 3.12.10, 4.2.2, 4.2.7, 6.1.3, 6.2.4, 7.1.3,
7.3.4, 7.3.6, 8.2, 10, 12, 14, 15.1.4

Coordination and Correlation
1.2, 3.2.1, 3.3.1, 3.10, 3.12.6, 6.1.3, 6.2.1

Copies Furnished of Drawings and Specifications
1.5, 2.3.6, 3.11

Copyrights
1.5, **3.17**

Correction of Work
2.5, 3.7.3, 9.4.2, 9.8.2, 9.8.3, 9.9.1, 12.1.2, **12.2**, 12.3,
15.1.3.1, 15.1.3.2, 15.2.1

Correlation and Intent of the Contract Documents
1.2

Cost, Definition of
7.3.4

Costs
2.5, 3.2.4, 3.7.3, 3.8.2, 3.15.2, 5.4.2, 6.1.1, 6.2.3,
7.3.3.3, 7.3.4, 7.3.8, 7.3.9, 9.10.2, 10.3.2, 10.3.6, 11.2,
12.1.2, 12.2.1, 12.2.4, 13.4, 14

Cutting and Patching
3.14, 6.2.5

Damage to Construction of Owner or Separate
Contractors
3.14.2, 6.2.4, 10.2.1.2, 10.2.5, 10.4, 12.2.4

Damage to the Work
3.14.2, 9.9.1, 10.2.1.2, 10.2.5, 10.4, 12.2.4

Damages, Claims for
3.2.4, 3.18, 6.1.1, 8.3.3, 9.5.1, 9.6.7, 10.3.3, 11.3.2,
11.3, 14.2.4, 15.1.7

Damages for Delay
6.2.3, 8.3.3, 9.5.1.6, 9.7, 10.3.2, 14.3.2

Date of Commencement of the Work, Definition of
8.1.2

Date of Substantial Completion, Definition of
8.1.3

Day, Definition of
8.1.4

Decisions of the Architect
3.7.4, 4.2.6, 4.2.7, 4.2.11, 4.2.12, 4.2.13, 6.3, 7.3.4,
7.3.9, 8.1.3, 8.3.1, 9.2, 9.4, 9.5.1, 9.8.4, 9.9.1, 13.4.2,
14.2.2, 14.2.4, 15.1, 15.2

Decisions to Withhold Certification
9.4.1, **9.5**, 9.7, 14.1.1.3

Defective or Nonconforming Work, Acceptance,
Rejection and Correction of
2.5, 3.5, 4.2.6, 6.2.3, 9.5.1, 9.5.3, 9.6.6, 9.8.2, 9.9.3,
9.10.4, 12.2.1

Definitions
1.1, 2.1.1, 3.1.1, 3.5, 3.12.1, 3.12.2, 3.12.3, 4.1.1, 5.1,
6.1.2, 7.2.1, 7.3.1, 8.1, 9.1, 9.8.1, 15.1.1

Delays and Extensions of Time
3.2, **3.7.4**, 5.2.3, 7.2.1, 7.3.1, **7.4**, **8.3**, 9.5.1, **9.7**,
10.3.2, **10.4**, 14.3.2, **15.1.6**, 15.2.5

Digital Data Use and Transmission
1.7

Disputes
6.3, 7.3.9, 15.1, 15.2

Documents and Samples at the Site
3.11

Drawings, Definition of
1.1.5

Drawings and Specifications, Use and Ownership of
3.11

Effective Date of Insurance
8.2.2

Emergencies
10.4, 14.1.1.2, **15.1.5**

Employees, Contractor's
3.3.2, 3.4.3, 3.8.1, 3.9, 3.18.2, 4.2.3, 4.2.6, 10.2,
10.3.3, 11.3, 14.1, 14.2.1.1

Equipment, Labor, or Materials
1.1.3, 1.1.6, 3.4, 3.5, 3.8.2, 3.8.3, 3.12, 3.13, 3.15.1,
4.2.6, 4.2.7, 5.2.1, 6.2.1, 7.3.4, 9.3.2, 9.3.3, 9.5.1.3,
9.10.2, 10.2.1, 10.2.4, 14.2.1.1, 14.2.1.2

Execution and Progress of the Work
1.1.3, 1.2.1, 1.2.2, 2.3.4, 2.3.6, 3.1, 3.3.1, 3.4.1, 3.7.1,
3.10.1, 3.12, 3.14, 4.2, 6.2.2, 7.1.3, 7.3.6, 8.2, 9.5.1,
9.9.1, 10.2, 10.3, 12.1, 12.2, 14.2, 14.3.1, 15.1.4

Extensions of Time
3.2.4, 3.7.4, 5.2.3, 7.2.1, 7.3, 7.4, 9.5.1, 9.7, 10.3.2, 10.4, 14.3, 15.1.6, **15.2.5**

Failure of Payment
9.5.1.3, **9.7**, 9.10.2, 13.5, 14.1.1.3, 14.2.1.2

Faulty Work
(See Defective or Nonconforming Work)

Final Completion and Final Payment
4.2.1, 4.2.9, 9.8.2, **9.10**, 12.3, 14.2.4, 14.4.3

Financial Arrangements, Owner's
2.2.1, 13.2.2, 14.1.1.4

GENERAL PROVISIONS

1

Governing Law

13.1
Guarantees (See Warranty)

Hazardous Materials and Substances
10.2.4, **10.3**

Identification of Subcontractors and Suppliers
5.2.1

Indemnification
3.17, **3.18**, 9.6.8, 9.10.2, 10.3.3, 11.3

Information and Services Required of the Owner
2.1.2, **2.2**, 2.3, 3.2.2, 3.12.10.1, 6.1.3, 6.1.4, 6.2.5, 9.6.1, 9.9.2, 9.10.3, 10.3.3, 11.2, 13.4.1, 13.4.2, 14.1.1.4, 14.1.4, 15.1.4

Initial Decision

15.2

Initial Decision Maker, Definition of
1.1.8

Initial Decision Maker, Decisions
14.2.4, 15.1.4.2, 15.2.1, 15.2.2, 15.2.3, 15.2.4, 15.2.5

Initial Decision Maker, Extent of Authority
14.2.4, 15.1.4.2, 15.2.1, 15.2.2, 15.2.3, 15.2.4, 15.2.5

Injury or Damage to Person or Property
10.2.8, 10.4

Inspections
3.1.3, 3.3.3, 3.7.1, 4.2.2, 4.2.6, 4.2.9, 9.4.2, 9.8.3, 9.9.2, 9.10.1, 12.2.1, 13.4

Instructions to Bidders
1.1.1

Instructions to the Contractor
3.2.4, 3.3.1, 3.8.1, 5.2.1, 7, 8.2.2, 12, 13.4.2

Instruments of Service, Definition of

1.1.7

Insurance
6.1.1, 7.3.4, 8.2.2, 9.3.2, 9.8.4, 9.9.1, 9.10.2, 10.2.5, **11**

Insurance, Notice of Cancellation or Expiration
11.1.4, 11.2.3

Insurance, Contractor's Liability

11.1
Insurance, Effective Date of
8.2.2, 14.4.2

Insurance, Owner's Liability

11.2

Insurance, Property
10.2.5, 11.2, 11.4, 11.5

Insurance, Stored Materials
9.3.2

INSURANCE AND BONDS

11
Insurance Companies, Consent to Partial Occupancy
9.9.1

Insured loss, Adjustment and Settlement of
11.5

Intent of the Contract Documents
1.2.1, 4.2.7, 4.2.12, 4.2.13

Interest

13.5

Interpretation
1.1.8, 1.2.3, **1.4**, 4.1.1, 5.1, 6.1.2, 15.1.1

Interpretations, Written
4.2.11, 4.2.12

Judgment on Final Award
15.4.2

Labor and Materials, Equipment
1.1.3, 1.1.6, **3.4**, 3.5, 3.8.2, 3.8.3, 3.12, 3.13, 3.15.1, 5.2.1, 6.2.1, 7.3.4, 9.3.2, 9.3.3, 9.5.1.3, 9.10.2, 10.2.1, 10.2.4, 14.2.1.1, 14.2.1.2

Labor Disputes
8.3.1

Laws and Regulations
1.5, 2.3.2, 3.2.3, 3.2.4, 3.6, 3.7, 3.12.10, 3.13, 9.6.4, 9.9.1, 10.2.2, 13.1, 13.3.1, 13.4.2, 13.5, 14, 15.2.8, 15.4

Liens
2.1.2, 9.3.1, 9.3.3, 9.6.8, 9.10.2, 9.10.4, 15.2.8

Limitations, Statutes of
12.2.5, 15.1.2, 15.4.1.1

Limitations of Liability
3.2.2, 3.5, 3.12.10, 3.12.10.1, 3.17, 3.18.1, 4.2.6, 4.2.7, 6.2.2, 9.4.2, 9.6.4, 9.6.7, 9.6.8, 10.2.5, 10.3.3, 11.3, 12.2.5, 13.3.1

Limitations of Time
2.1.2, 2.2, 2.5, 3.2.2, 3.10, 3.11, 3.12.5, 3.15.1, 4.2.7, 5.2, 5.3, 5.4.1, 6.2.4, 7.3, 7.4, 8.2, 9.2, 9.3.1, 9.3.3, 9.4.1, 9.5, 9.6, 9.7, 9.8, 9.9, 9.10, 12.2, 13.4, 14, 15, 15.1.2, 15.1.3, 15.1.5

Materials, Hazardous
10.2.4, **10.3**

Materials, Labor, Equipment and
1.1.3, 1.1.6, 3.4.1, 3.5, 3.8.2, 3.8.3, 3.12, 3.13, 3.15.1, 5.2.1, 6.2.1, 7.3.4, 9.3.2, 9.3.3, 9.5.1.3, 9.10.2, 10.2.1.2, 10.2.4, 14.2.1.1, 14.2.1.2

Means, Methods, Techniques, Sequences and Procedures of Construction
3.3.1, 3.12.10, 4.2.2, 4.2.7, 9.4.2

Mechanic's Lien
2.1.2, 9.3.1, 9.3.3, 9.6.8, 9.10.2, 9.10.4, 15.2.8

Mediation
8.3.1, 15.1.3.2, 15.2.1, 15.2.5, 15.2.6, **15.3**, 15.4.1, 15.4.1.1

Minor Changes in the Work
1.1.1, 3.4.2, 3.12.8, 4.2.8, 7.1, **7.4**

MISCELLANEOUS PROVISIONS

13

Modifications, Definition of

1.1.1

Modifications to the Contract

1.1.1, 1.1.2, 2.5, 3.11, 4.1.2, 4.2.1, 5.2.3, 7, 8.3.1, 9.7, 10.3.2

Mutual Responsibility

6.2

Nonconforming Work, Acceptance of

9.6.6, 9.9.3, **12.3**

Nonconforming Work, Rejection and Correction of
2.4, 2.5, 3.5, 4.2.6, 6.2.4, 9.5.1, 9.8.2, 9.9.3, 9.10.4, 12.2

Notice

1.6, 1.6.1, 1.6.2, 2.1.2, 2.2.2., 2.2.3, 2.2.4, 2.5, 3.2.4, 3.3.1, 3.7.4, 3.7.5, 3.9.2, 3.12.9, 3.12.10, 5.2.1, 7.4, 8.2.2, 9.6.8, 9.7, 9.10.1, 10.2.8, 10.3.2, 11.5, 12.2.2.1, 13.4.1, 13.4.2, 14.1, 14.2.2, 14.4.2, 15.1.3, 15.1.5, 15.1.6, 15.4.1

Notice of Cancellation or Expiration of Insurance

11.1.4, 11.2.3

Notice of Claims

1.6.2, 2.1.2, 3.7.4, 9.6.8, 10.2.8, **15.1.3**, 15.1.5, 15.1.6, 15.2.8, 15.3.2, 15.4.1

Notice of Testing and Inspections

13.4.1, 13.4.2

Observations, Contractor's

3.2, 3.7.4

Occupancy

2.3.1, 9.6.6, 9.8

Orders, Written

1.1.1, 2.4, 3.9.2, 7, 8.2.2, 11.5, 12.1, 12.2.2.1, 13.4.2, 14.3.1

OWNER

2

Owner, Definition of

2.1.1

Owner, Evidence of Financial Arrangements

2.2, 13.2.2, 14.1.1.4

Owner, Information and Services Required of the

2.1.2, **2.2**, 2.3, 3.2.2, 3.12.10, 6.1.3, 6.1.4, 6.2.5, 9.3.2, 9.6.1, 9.6.4, 9.9.2, 9.10.3, 10.3.3, 11.2, 13.4.1, 13.4.2, 14.1.1.4, 14.1.4, 15.1.4

Owner's Authority

1.5, 2.1.1, 2.3.32.4, 2.5, 3.4.2, 3.8.1, 3.12.10, 3.14.2, 4.1.2, 4.2.4, 4.2.9, 5.2.1, 5.2.4, 5.4.1, 6.1, 6.3, 7.2.1, 7.3.1, 8.2.2, 8.3.1, 9.3.2, 9.5.1, 9.6.4, 9.9.1, 9.10.2, 10.3.2, 11.4, 11.5, 12.2.2, 12.3, 13.2.2, 14.3, 14.4, 15.2.7

Owner's Insurance

11.2

Owner's Relationship with Subcontractors

1.1.2, 5.2, 5.3, 5.4, 9.6.4, 9.10.2, 14.2.2

Owner's Right to Carry Out the Work

2.5, 14.2.2

Owner's Right to Clean Up

6.3

Owner's Right to Perform Construction and to Award Separate Contracts

6.1

Owner's Right to Stop the Work

2.4

Owner's Right to Suspend the Work

14.3

Owner's Right to Terminate the Contract

14.2, 14.4

Ownership and Use of Drawings, Specifications and Other Instruments of Service

1.1.1, 1.1.6, 1.1.7, **1.5**, 2.3.6, 3.2.2, 3.11, 3.17, 4.2.12, 5.3

Partial Occupancy or Use

9.6.6, **9.9**

Patching, Cutting and

3.14, 6.2.5

Patents

3.17

Payment, Applications for

4.2.5, 7.3.9, 9.2, **9.3**, 9.4, 9.5, 9.6.3, 9.7, 9.8.5, 9.10.1, 14.2.3, 14.2.4, 14.4.3

Payment, Certificates for

4.2.5, 4.2.9, 9.3.3, **9.4**, 9.5, 9.6.1, 9.6.6, 9.7, 9.10.1, 9.10.3, 14.1.1.3, 14.2.4

Payment, Failure of

9.5.1.3, **9.7**, 9.10.2, 13.5, 14.1.1.3, 14.2.1.2

Payment, Final

4.2.1, 4.2.9, **9.10**, 12.3, 14.2.4, 14.4.3

Payment Bond, Performance Bond and

7.3.4.4, 9.6.7, 9.10.3, **11.1.2**

Payments, Progress

9.3, **9.6**, 9.8.5, 9.10.3, 14.2.3, 15.1.4

PAYMENTS AND COMPLETION

9

Payments to Subcontractors

5.4.2, 9.5.1.3, 9.6.2, 9.6.3, 9.6.4, 9.6.7, 14.2.1.2

PCB

10.3.1

Performance Bond and Payment Bond

7.3.4.4, 9.6.7, 9.10.3, **11.1.2**

Permits, Fees, Notices and Compliance with Laws

2.3.1, **3.7**, 3.13, 7.3.4.4, 10.2.2

PERSONS AND PROPERTY, PROTECTION OF

10

Polychlorinated Biphenyl

10.3.1

Product Data, Definition of

3.12.2

Product Data and Samples, Shop Drawings

3.11, **3.12**, 4.2.7

Progress and Completion

4.2.2, **8.2**, 9.8, 9.9.1, 14.1.4, 15.1.4

Progress Payments

9.3, **9.6**, 9.8.5, 9.10.3, 14.2.3, 15.1.4

Init.

/

Project, Definition of
1.1.4
Project Representatives
4.2.10
Property Insurance
10.2.5, **11.2**
Proposal Requirements
1.1.1
PROTECTION OF PERSONS AND PROPERTY
10
Regulations and Laws
1.5, 2.3.2, 3.2.3, 3.6, 3.7, 3.12.10, 3.13, 9.6.4, 9.9.1,
10.2.2, 13.1, 13.3, 13.4.1, 13.4.2, 13.5, 14, 15.2.8, 15.4
Rejection of Work
4.2.6, 12.2.1
Releases and Waivers of Liens
9.3.1, 9.10.2
Representations
3.2.1, 3.5, 3.12.6, 8.2.1, 9.3.3, 9.4.2, 9.5.1, 9.10.1
Representatives
2.1.1, 3.1.1, 3.9, 4.1.1, 4.2.10, 13.2.1
Responsibility for Those Performing the Work
3.3.2, 3.18, 4.2.2, 4.2.3, 5.3, 6.1.3, 6.2, 6.3, 9.5.1, 10
Retainage
9.3.1, 9.6.2, 9.8.5, 9.9.1, 9.10.2, 9.10.3
Review of Contract Documents and Field
Conditions by Contractor
3.2, 3.12.7, 6.1.3
Review of Contractor's Submittals by Owner and
Architect
3.10.1, 3.10.2, 3.11, 3.12, 4.2, 5.2, 6.1.3, 9.2, 9.8.2
Review of Shop Drawings, Product Data and Samples
by Contractor
3.12
Rights and Remedies
1.1.2, 2.4, 2.5, 3.5, 3.7.4, 3.15.2, 4.2.6, 5.3, 5.4, 6.1,
6.3, 7.3.1, 8.3, 9.5.1, 9.7, 10.2.5, 10.3, 12.2.1, 12.2.2,
12.2.4, **13.3**, 14, 15.4
Royalties, Patents and Copyrights
3.17
Rules and Notices for Arbitration
15.4.1
Safety of Persons and Property
10.2, 10.4
Safety Precautions and Programs
3.3.1, 4.2.2, 4.2.7, 5.3, **10.1**, 10.2, 10.4
Samples, Definition of
3.12.3
Samples, Shop Drawings, Product Data and
3.11, **3.12**, 4.2.7
Samples at the Site, Documents and
3.11
Schedule of Values
9.2, 9.3.1
Schedules, Construction
3.10, 3.12.1, 3.12.2, 6.1.3, 15.1.6.2

Separate Contracts and Contractors
1.1.4, 3.12.5, 3.14.2, 4.2.4, 4.2.7, 6, 8.3.1, 12.1.2
Separate Contractors, Definition of
6.1.1
Shop Drawings, Definition of
3.12.1
Shop Drawings, Product Data and Samples
3.11, **3.12**, 4.2.7
Site, Use of
3.13, 6.1.1, 6.2.1
Site Inspections
3.2.2, 3.3.3, 3.7.1, 3.7.4, 4.2, 9.9.2, 9.4.2, 9.10.1, 13.4
Site Visits, Architect's
3.7.4, 4.2.2, 4.2.9, 9.4.2, 9.5.1, 9.9.2, 9.10.1, 13.4
Special Inspections and Testing
4.2.6, 12.2.1, 13.4
Specifications, Definition of
1.1.6
Specifications
1.1.1, **1.1.6**, 1.2.2, 1.5, 3.12.10, 3.17, 4.2.14
Statute of Limitations
15.1.2, 15.4.1.1
Stopping the Work
2.2.2, 2.4, 9.7, 10.3, 14.1
Stored Materials
6.2.1, 9.3.2, 10.2.1.2, 10.2.4
Subcontractor, Definition of
5.1.1
SUBCONTRACTORS
5
Subcontractors, Work by
1.2.2, 3.3.2, 3.12.1, 3.18, 4.2.3, 5.2.3, 5.3, 5.4, 9.3.1.2,
9.6.7
Subcontractual Relations
5.3, 5.4, 9.3.1.2, 9.6, 9.10, 10.2.1, 14.1, 14.2.1
Submittals
3.10, 3.11, 3.12, 4.2.7, 5.2.1, 5.2.3, 7.3.4, 9.2, 9.3, 9.8,
9.9.1, 9.10.2, 9.10.3
Submittal Schedule
3.10.2, 3.12.5, 4.2.7
Subrogation, Waivers of
6.1.1, **11.3**
Substances, Hazardous
10.3
Substantial Completion
4.2.9, 8.1.1, 8.1.3, 8.2.3, 9.4.2, **9.8**, 9.9.1, 9.10.3, 12.2,
15.1.2
Substantial Completion, Definition of
9.8.1
Substitution of Subcontractors
5.2.3, 5.2.4
Substitution of Architect
2.3.3
Substitutions of Materials
3.4.2, 3.5, 7.3.8
Sub-subcontractor, Definition of
5.1.2

Subsurface Conditions

3.7.4

Successors and Assigns

13.2

Superintendent

3.9, 10.2.6

Supervision and Construction Procedures

1.2.2, **3.3**, 3.4, 3.12.10, 4.2.2, 4.2.7, 6.1.3, 6.2.4, 7.1.3, 7.3.4, 8.2, 8.3.1, 9.4.2, 10, 12, 14, 15.1.4

Suppliers

1.5, 3.12.1, 4.2.4, 4.2.6, 5.2.1, 9.3, 9.4.2, 9.5.4, 9.6, 9.10.5, 14.2.1

Surety

5.4.1.2, 9.6.8, 9.8.5, 9.10.2, 9.10.3, 11.1.2, 14.2.2, 15.2.7

Surety, Consent of

9.8.5, 9.10.2, 9.10.3

Surveys

1.1.7, 2.3.4

Suspension by the Owner for Convenience

14.3

Suspension of the Work

3.7.5, 5.4.2, 14.3

Suspension or Termination of the Contract

5.4.1.1, 14

Taxes

3.6, 3.8.2.1, 7.3.4.4

Termination by the Contractor

14.1, 15.1.7

Termination by the Owner for Cause

5.4.1.1, **14.2**, 15.1.7

Termination by the Owner for Convenience

14.4

Termination of the Architect

2.3.3

Termination of the Contractor Employment

14.2.2

TERMINATION OR SUSPENSION OF THE CONTRACT

14

Tests and Inspections

3.1.3, 3.3.3, 3.7.1, 4.2.2, 4.2.6, 4.2.9, 9.4.2, 9.8.3, 9.9.2, 9.10.1, 10.3.2, 12.2.1, **13.4**

TIME

8

Time, Delays and Extensions of

3.2.4, 3.7.4, 5.2.3, 7.2.1, 7.3.1, 7.4, **8.3**, 9.5.1, 9.7, 10.3.2, 10.4, 14.3.2, 15.1.6, 15.2.5

Time Limits

2.1.2, 2.2, 2.5, 3.2.2, 3.10, 3.11, 3.12.5, 3.15.1, 4.2, 5.2, 5.3, 5.4, 6.2.4, 7.3, 7.4, 8.2, 9.2, 9.3.1, 9.3.3, 9.4.1, 9.5, 9.6, 9.7, 9.8, 9.9, 9.10, 12.2, 13.4, 14, 15.1.2, 15.1.3, 15.4

Time Limits on Claims

3.7.4, 10.2.8, 15.1.2, 15.1.3

Title to Work

9.3.2, 9.3.3

UNCOVERING AND CORRECTION OF WORK

12

Uncovering of Work

12.1

Unforeseen Conditions, Concealed or Unknown

3.7.4, 8.3.1, 10.3

Unit Prices

7.3.3.2, 9.1.2

Use of Documents

1.1.1, 1.5, 2.3.6, 3.12.6, 5.3

Use of Site

3.13, 6.1.1, 6.2.1

Values, Schedule of

9.2, 9.3.1

Waiver of Claims by the Architect

13.3.2

Waiver of Claims by the Contractor

9.10.5, 13.3.2, **15.1.7**

Waiver of Claims by the Owner

9.9.3, 9.10.3, 9.10.4, 12.2.2.1, 13.3.2, 14.2.4, **15.1.7**

Waiver of Consequential Damages

14.2.4, 15.1.7

Waiver of Liens

9.3, 9.10.2, 9.10.4

Waivers of Subrogation

6.1.1, **11.3**

Warranty

3.5, 4.2.9, 9.3.3, 9.8.4, 9.9.1, 9.10.2, 9.10.4, 12.2.2, 15.1.2

Weather Delays

8.3, 15.1.6.2

Work, Definition of

1.1.3

Written Consent

1.5.2, 3.4.2, 3.7.4, 3.12.8, 3.14.2, 4.1.2, 9.3.2, 9.10.3, 13.2, 13.3.2, 15.4.4.2

Written Interpretations

4.2.11, 4.2.12

Written Orders

1.1.1, 2.4, 3.9, 7, 8.2.2, 12.1, 12.2, 13.4.2, 14.3.1

ARTICLE 1 GENERAL PROVISIONS

§ 1.1 Basic Definitions

§ 1.1.1 The Contract Documents

The Contract Documents are enumerated in the Agreement between the Owner and Contractor (hereinafter the Agreement) and consist of the Agreement, Conditions of the Contract (General, Supplementary and other Conditions), Drawings, Specifications, Addenda issued prior to execution of the Contract, other documents listed in the Agreement, and Modifications issued after execution of the Contract. A Modification is (1) a written amendment to the Contract signed by both parties, (2) a Change Order, (3) a Construction Change Directive, or (4) a written order for a minor change in the Work issued by the Architect. Unless specifically enumerated in the Agreement, the Contract Documents do not include the advertisement or invitation to bid, Instructions to Bidders, sample forms, other information furnished by the Owner in anticipation of receiving bids or proposals, the Contractor's bid or proposal, or portions of Addenda relating to bidding or proposal requirements.

§ 1.1.2 The Contract

The Contract Documents form the Contract for Construction. The Contract represents the entire and integrated agreement between the parties hereto and supersedes prior negotiations, representations, or agreements, either written or oral. The Contract may be amended or modified only by a Modification. The Contract Documents shall not be construed to create a contractual relationship of any kind (1) between the Contractor and the Architect or the Architect's consultants, (2) between the Owner and a Subcontractor or a Sub-subcontractor, (3) between the Owner and the Architect or the Architect's consultants, or (4) between any persons or entities other than the Owner and the Contractor. The Architect shall, however, be entitled to performance and enforcement of obligations under the Contract intended to facilitate performance of the Architect's duties.

§ 1.1.3 The Work

The term "Work" means the construction and services required by the Contract Documents, whether completed or partially completed, and includes all other labor, materials, equipment, and services provided or to be provided by the Contractor to fulfill the Contractor's obligations. The Work may constitute the whole or a part of the Project.

§ 1.1.4 The Project

The Project is the total construction of which the Work performed under the Contract Documents may be the whole or a part and which may include construction by the Owner and by Separate Contractors.

§ 1.1.5 The Drawings

The Drawings are the graphic and pictorial portions of the Contract Documents showing the design, location and dimensions of the Work, generally including plans, elevations, sections, details, schedules, and diagrams.

§ 1.1.6 The Specifications

The Specifications are that portion of the Contract Documents consisting of the written requirements for materials, equipment, systems, standards and workmanship for the Work, and performance of related services.

§ 1.1.7 Instruments of Service

Instruments of Service are representations, in any medium of expression now known or later developed, of the tangible and intangible creative work performed by the Architect and the Architect's consultants under their respective professional services agreements. Instruments of Service may include, without limitation, studies, surveys, models, sketches, drawings, specifications, and other similar materials.

§ 1.1.8 Initial Decision Maker

The Initial Decision Maker is the person identified in the Agreement to render initial decisions on Claims in accordance with Section 15.2. The Initial Decision Maker shall not show partiality to the Owner or Contractor and shall not be liable for results of interpretations or decisions rendered in good faith.

§ 1.2 Correlation and Intent of the Contract Documents

§ 1.2.1 The intent of the Contract Documents is to include all items necessary for the proper execution and completion of the Work by the Contractor. The Contract Documents are complementary, and what is required by one shall be as binding as if required by all; performance by the Contractor shall be required only to the extent consistent with the Contract Documents and reasonably inferable from them as being necessary to produce the indicated results.

§ 1.2.1.1 The invalidity of any provision of the Contract Documents shall not invalidate the Contract or its remaining provisions. If it is determined that any provision of the Contract Documents violates any law, or is otherwise invalid or unenforceable, then that provision shall be revised to the extent necessary to make that provision legal and enforceable. In such case the Contract Documents shall be construed, to the fullest extent permitted by law, to give effect to the parties' intentions and purposes in executing the Contract.

§ 1.2.2 Organization of the Specifications into divisions, sections and articles, and arrangement of Drawings shall not control the Contractor in dividing the Work among Subcontractors or in establishing the extent of Work to be performed by any trade.

§ 1.2.3 Unless otherwise stated in the Contract Documents, words that have well-known technical or construction industry meanings are used in the Contract Documents in accordance with such recognized meanings.

§ 1.3 Capitalization

Terms capitalized in these General Conditions include those that are (1) specifically defined, (2) the titles of numbered articles, or (3) the titles of other documents published by the American Institute of Architects.

§ 1.4 Interpretation

In the interest of brevity the Contract Documents frequently omit modifying words such as "all" and "any" and articles such as "the" and "an," but the fact that a modifier or an article is absent from one statement and appears in another is not intended to affect the interpretation of either statement.

§ 1.5 Ownership and Use of Drawings, Specifications, and Other Instruments of Service

§ 1.5.1 The Architect and the Architect's consultants shall be deemed the authors and owners of their respective Instruments of Service, including the Drawings and Specifications, and retain all common law, statutory, and other reserved rights in their Instruments of Service, including copyrights. The Contractor, Subcontractors, Sub-subcontractors, and suppliers shall not own or claim a copyright in the Instruments of Service. Submittal or distribution to meet official regulatory requirements or for other purposes in connection with the Project is not to be construed as publication in derogation of the Architect's or Architect's consultants' reserved rights.

§ 1.5.2 The Contractor, Subcontractors, Sub-subcontractors, and suppliers are authorized to use and reproduce the Instruments of Service provided to them, subject to any protocols established pursuant to Sections 1.7 and 1.8, solely and exclusively for execution of the Work. All copies made under this authorization shall bear the copyright notice, if any, shown on the Instruments of Service. The Contractor, Subcontractors, Sub-subcontractors, and suppliers may not use the Instruments of Service on other projects or for additions to the Project outside the scope of the Work without the specific written consent of the Owner, Architect, and the Architect's consultants.

§ 1.6 Notice

§ 1.6.1 Except as otherwise provided in Section 1.6.2, where the Contract Documents require one party to notify or give notice to the other party, such notice shall be provided in writing to the designated representative of the party to whom the notice is addressed and shall be deemed to have been duly served if delivered in person, by mail, by courier, or by electronic transmission if a method for electronic transmission is set forth in the Agreement.

§ 1.6.2 Notice of Claims as provided in Section 15.1.3 shall be provided in writing and shall be deemed to have been duly served only if delivered to the designated representative of the party to whom the notice is addressed by certified or registered mail, or by courier providing proof of delivery.

§ 1.7 Digital Data Use and Transmission

The parties shall agree upon protocols governing the transmission and use of Instruments of Service or any other information or documentation in digital form. The parties will use AIA Document E203™–2013, Building Information Modeling and Digital Data Exhibit, to establish the protocols for the development, use, transmission, and exchange of digital data.

§ 1.8 Building Information Models Use and Reliance

Any use of, or reliance on, all or a portion of a building information model without agreement to protocols governing the use of, and reliance on, the information contained in the model and without having those protocols set forth in AIA Document E203™–2013, Building Information Modeling and Digital Data Exhibit, and the requisite AIA Document

G202™–2013, Project Building Information Modeling Protocol Form, shall be at the using or relying party's sole risk and without liability to the other party and its contractors or consultants, the authors of, or contributors to, the building information model, and each of their agents and employees.

ARTICLE 2 OWNER

§ 2.1 General

§ 2.1.1 The Owner is the person or entity identified as such in the Agreement and is referred to throughout the Contract Documents as if singular in number. The Owner shall designate in writing a representative who shall have express authority to bind the Owner with respect to all matters requiring the Owner's approval or authorization. Except as otherwise provided in Section 4.2.1, the Architect does not have such authority. The term "Owner" means the Owner or the Owner's authorized representative.

§ 2.1.2 The Owner shall furnish to the Contractor, within fifteen days after receipt of a written request, information necessary and relevant for the Contractor to evaluate, give notice of, or enforce mechanic's lien rights. Such information shall include a correct statement of the record legal title to the property on which the Project is located, usually referred to as the site, and the Owner's interest therein.

§ 2.2 Evidence of the Owner's Financial Arrangements

§ 2.2.1 Prior to commencement of the Work and upon written request by the Contractor, the Owner shall furnish to the Contractor reasonable evidence that the Owner has made financial arrangements to fulfill the Owner's obligations under the Contract. The Contractor shall have no obligation to commence the Work until the Owner provides such evidence. If commencement of the Work is delayed under this Section 2.2.1, the Contract Time shall be extended appropriately.

§ 2.2.2 Following commencement of the Work and upon written request by the Contractor, the Owner shall furnish to the Contractor reasonable evidence that the Owner has made financial arrangements to fulfill the Owner's obligations under the Contract only if (1) the Owner fails to make payments to the Contractor as the Contract Documents require; (2) the Contractor identifies in writing a reasonable concern regarding the Owner's ability to make payment when due; or (3) a change in the Work materially changes the Contract Sum. If the Owner fails to provide such evidence, as required, within fourteen days of the Contractor's request, the Contractor may immediately stop the Work and, in that event, shall notify the Owner that the Work has stopped. However, if the request is made because a change in the Work materially changes the Contract Sum under (3) above, the Contractor may immediately stop only that portion of the Work affected by the change until reasonable evidence is provided. If the Work is stopped under this Section 2.2.2, the Contract Time shall be extended appropriately and the Contract Sum shall be increased by the amount of the Contractor's reasonable costs of shutdown, delay and start-up, plus interest as provided in the Contract Documents.

§ 2.2.3 After the Owner furnishes evidence of financial arrangements under this Section 2.2, the Owner shall not materially vary such financial arrangements without prior notice to the Contractor.

§ 2.2.4 Where the Owner has designated information furnished under this Section 2.2 as "confidential," the Contractor shall keep the information confidential and shall not disclose it to any other person. However, the Contractor may disclose "confidential" information, after seven (7) days' notice to the Owner, where disclosure is required by law, including a subpoena or other form of compulsory legal process issued by a court or governmental entity, or by court or arbitrator(s) order. The Contractor may also disclose "confidential" information to its employees, consultants, sureties, Subcontractors and their employees, Sub-subcontractors, and others who need to know the content of such information solely and exclusively for the Project and who agree to maintain the confidentiality of such information.

§ 2.3 Information and Services Required of the Owner

§ 2.3.1 Except for permits and fees that are the responsibility of the Contractor under the Contract Documents, including those required under Section 3.7.1, the Owner shall secure and pay for necessary approvals, easements, assessments and charges required for construction, use or occupancy of permanent structures or for permanent changes in existing facilities.

§ 2.3.2 The Owner shall retain an architect lawfully licensed to practice architecture, or an entity lawfully practicing architecture, in the jurisdiction where the Project is located. That person or entity is identified as the Architect in the Agreement and is referred to throughout the Contract Documents as if singular in number.

§ 2.3.3 If the employment of the Architect terminates, the Owner shall employ a successor to whom the Contractor has no reasonable objection and whose status under the Contract Documents shall be that of the Architect.

§ 2.3.4 The Owner shall furnish surveys describing physical characteristics, legal limitations and utility locations for the site of the Project, and a legal description of the site. The Contractor shall be entitled to rely on the accuracy of information furnished by the Owner but shall exercise proper precautions relating to the safe performance of the Work.

§ 2.3.5 The Owner shall furnish information or services required of the Owner by the Contract Documents with reasonable promptness. The Owner shall also furnish any other information or services under the Owner's control and relevant to the Contractor's performance of the Work with reasonable promptness after receiving the Contractor's written request for such information or services.

§ 2.3.6 Unless otherwise provided in the Contract Documents, the Owner shall furnish to the Contractor one copy of the Contract Documents for purposes of making reproductions pursuant to Section 1.5.2.

§ 2.4 Owner's Right to Stop the Work

If the Contractor fails to correct Work that is not in accordance with the requirements of the Contract Documents as required by Section 12.2 or repeatedly fails to carry out Work in accordance with the Contract Documents, the Owner may issue a written order to the Contractor to stop the Work, or any portion thereof, until the cause for such order has been eliminated; however, the right of the Owner to stop the Work shall not give rise to a duty on the part of the Owner to exercise this right for the benefit of the Contractor or any other person or entity, except to the extent required by Section 6.1.3.

§ 2.5 Owner's Right to Carry Out the Work

If the Contractor defaults or neglects to carry out the Work in accordance with the Contract Documents and fails within a ten-day period after receipt of notice from the Owner to commence and continue correction of such default or neglect with diligence and promptness, the Owner may, without prejudice to other remedies the Owner may have, correct such default or neglect. Such action by the Owner and amounts charged to the Contractor are both subject to prior approval of the Architect and the Architect may, pursuant to Section 9.5.1, withhold or nullify a Certificate for Payment in whole or in part, to the extent reasonably necessary to reimburse the Owner for the reasonable cost of correcting such deficiencies, including Owner's expenses and compensation for the Architect's additional services made necessary by such default, neglect, or failure. If current and future payments are not sufficient to cover such amounts, the Contractor shall pay the difference to the Owner. If the Contractor disagrees with the actions of the Owner or the Architect, or the amounts claimed as costs to the Owner, the Contractor may file a Claim pursuant to Article 15.

ARTICLE 3 CONTRACTOR

§ 3.1 General

§ 3.1.1 The Contractor is the person or entity identified as such in the Agreement and is referred to throughout the Contract Documents as if singular in number. The Contractor shall be lawfully licensed, if required in the jurisdiction where the Project is located. The Contractor shall designate in writing a representative who shall have express authority to bind the Contractor with respect to all matters under this Contract. The term "Contractor" means the Contractor or the Contractor's authorized representative.

§ 3.1.2 The Contractor shall perform the Work in accordance with the Contract Documents.

§ 3.1.3 The Contractor shall not be relieved of its obligations to perform the Work in accordance with the Contract Documents either by activities or duties of the Architect in the Architect's administration of the Contract, or by tests, inspections or approvals required or performed by persons or entities other than the Contractor.

§ 3.2 Review of Contract Documents and Field Conditions by Contractor

§ 3.2.1 Execution of the Contract by the Contractor is a representation that the Contractor has visited the site, become generally familiar with local conditions under which the Work is to be performed, and correlated personal observations with requirements of the Contract Documents.

§ 3.2.2 Because the Contract Documents are complementary, the Contractor shall, before starting each portion of the Work, carefully study and compare the various Contract Documents relative to that portion of the Work, as well as the information furnished by the Owner pursuant to Section 2.3.4, shall take field measurements of any existing conditions related to that portion of the Work, and shall observe any conditions at the site affecting it. These obligations are for the purpose of facilitating coordination and construction by the Contractor and are not for the purpose of discovering errors, omissions, or inconsistencies in the Contract Documents; however, the Contractor shall promptly report to the Architect any errors, inconsistencies or omissions discovered by or made known to the Contractor as a request for information in such form as the Architect may require. It is recognized that the Contractor's review is made in the Contractor's capacity as a contractor and not as a licensed design professional, unless otherwise specifically provided in the Contract Documents.

§ 3.2.3 The Contractor is not required to ascertain that the Contract Documents are in accordance with applicable laws, statutes, ordinances, codes, rules and regulations, or lawful orders of public authorities, but the Contractor shall promptly report to the Architect any nonconformity discovered by or made known to the Contractor as a request for information in such form as the Architect may require.

§ 3.2.4 If the Contractor believes that additional cost or time is involved because of clarifications or instructions the Architect issues in response to the Contractor's notices or requests for information pursuant to Sections 3.2.2 or 3.2.3, the Contractor shall submit Claims as provided in Article 15. If the Contractor fails to perform the obligations of Sections 3.2.2 or 3.2.3, the Contractor shall pay such costs and damages to the Owner, subject to Section 15.1.7, as would have been avoided if the Contractor had performed such obligations. If the Contractor performs those obligations, the Contractor shall not be liable to the Owner or Architect for damages resulting from errors, inconsistencies or omissions in the Contract Documents, for differences between field measurements or conditions and the Contract Documents, or for nonconformities of the Contract Documents to applicable laws, statutes, ordinances, codes, rules and regulations, and lawful orders of public authorities.

§ 3.3 Supervision and Construction Procedures

§ 3.3.1 The Contractor shall supervise and direct the Work, using the Contractor's best skill and attention. The Contractor shall be solely responsible for, and have control over, construction means, methods, techniques, sequences, and procedures, and for coordinating all portions of the Work under the Contract. If the Contract Documents give specific instructions concerning construction means, methods, techniques, sequences, or procedures, the Contractor shall evaluate the jobsite safety thereof and shall be solely responsible for the jobsite safety of such means, methods, techniques, sequences, or procedures. If the Contractor determines that such means, methods, techniques, sequences or procedures may not be safe, the Contractor shall give timely notice to the Owner and Architect, and shall propose alternative means, methods, techniques, sequences, or procedures. The Architect shall evaluate the proposed alternative solely for conformance with the design intent for the completed construction. Unless the Architect objects to the Contractor's proposed alternative, the Contractor shall perform the Work using its alternative means, methods, techniques, sequences, or procedures.

§ 3.3.2 The Contractor shall be responsible to the Owner for acts and omissions of the Contractor's employees, Subcontractors and their agents and employees, and other persons or entities performing portions of the Work for, or on behalf of, the Contractor or any of its Subcontractors.

§ 3.3.3 The Contractor shall be responsible for inspection of portions of Work already performed to determine that such portions are in proper condition to receive subsequent Work.

§ 3.4 Labor and Materials

§ 3.4.1 Unless otherwise provided in the Contract Documents, the Contractor shall provide and pay for labor, materials, equipment, tools, construction equipment and machinery, water, heat, utilities, transportation, and other facilities and services necessary for proper execution and completion of the Work, whether temporary or permanent and whether or not incorporated or to be incorporated in the Work.

§ 3.4.2 Except in the case of minor changes in the Work approved by the Architect in accordance with Section 3.12.8 or ordered by the Architect in accordance with Section 7.4, the Contractor may make substitutions only with the consent of the Owner, after evaluation by the Architect and in accordance with a Change Order or Construction Change Directive.

§ 3.4.3 The Contractor shall enforce strict discipline and good order among the Contractor's employees and other persons carrying out the Work. The Contractor shall not permit employment of unfit persons or persons not properly skilled in tasks assigned to them.

§ 3.5 Warranty

§ 3.5.1 The Contractor warrants to the Owner and Architect that materials and equipment furnished under the Contract will be of good quality and new unless the Contract Documents require or permit otherwise. The Contractor further warrants that the Work will conform to the requirements of the Contract Documents and will be free from defects, except for those inherent in the quality of the Work the Contract Documents require or permit. Work, materials, or equipment not conforming to these requirements may be considered defective. The Contractor's warranty excludes remedy for damage or defect caused by abuse, alterations to the Work not executed by the Contractor, improper or insufficient maintenance, improper operation, or normal wear and tear and normal usage. If required by the Architect, the Contractor shall furnish satisfactory evidence as to the kind and quality of materials and equipment.

§ 3.5.2 All material, equipment, or other special warranties required by the Contract Documents shall be issued in the name of the Owner, or shall be transferable to the Owner, and shall commence in accordance with Section 9.8.4.

§ 3.6 Taxes

The Contractor shall pay sales, consumer, use and similar taxes for the Work provided by the Contractor that are legally enacted when bids are received or negotiations concluded, whether or not yet effective or merely scheduled to go into effect.

§ 3.7 Permits, Fees, Notices and Compliance with Laws

§ 3.7.1 Unless otherwise provided in the Contract Documents, the Contractor shall secure and pay for the building permit as well as for other permits, fees, licenses, and inspections by government agencies necessary for proper execution and completion of the Work that are customarily secured after execution of the Contract and legally required at the time bids are received or negotiations concluded.

§ 3.7.2 The Contractor shall comply with and give notices required by applicable laws, statutes, ordinances, codes, rules and regulations, and lawful orders of public authorities applicable to performance of the Work.

§ 3.7.3 If the Contractor performs Work knowing it to be contrary to applicable laws, statutes, ordinances, codes, rules and regulations, or lawful orders of public authorities, the Contractor shall assume appropriate responsibility for such Work and shall bear the costs attributable to correction.

§ 3.7.4 Concealed or Unknown Conditions

If the Contractor encounters conditions at the site that are (1) subsurface or otherwise concealed physical conditions that differ materially from those indicated in the Contract Documents or (2) unknown physical conditions of an unusual nature that differ materially from those ordinarily found to exist and generally recognized as inherent in construction activities of the character provided for in the Contract Documents, the Contractor shall promptly provide notice to the Owner and the Architect before conditions are disturbed and in no event later than 14 days after first observance of the conditions. The Architect will promptly investigate such conditions and, if the Architect determines that they differ materially and cause an increase or decrease in the Contractor's cost of, or time required for, performance of any part of the Work, will recommend that an equitable adjustment be made in the Contract Sum or Contract Time, or both. If the Architect determines that the conditions at the site are not materially different from those indicated in the Contract Documents and that no change in the terms of the Contract is justified, the Architect shall promptly notify the Owner and Contractor, stating the reasons. If either party disputes the Architect's determination or recommendation, that party may submit a Claim as provided in Article 15.

§ 3.7.5 If, in the course of the Work, the Contractor encounters human remains or recognizes the existence of burial markers, archaeological sites or wetlands not indicated in the Contract Documents, the Contractor shall immediately suspend any operations that would affect them and shall notify the Owner and Architect. Upon receipt of such notice, the Owner shall promptly take any action necessary to obtain governmental authorization required to resume the operations. The Contractor shall continue to suspend such operations until otherwise instructed by the Owner but shall continue with all other operations that do not affect those remains or features. Requests for adjustments in the Contract Sum and Contract Time arising from the existence of such remains or features may be made as provided in Article 15.

§ 3.8 Allowances

§ 3.8.1 The Contractor shall include in the Contract Sum all allowances stated in the Contract Documents. Items covered by allowances shall be supplied for such amounts and by such persons or entities as the Owner may direct, but the Contractor shall not be required to employ persons or entities to whom the Contractor has reasonable objection.

§ 3.8.2 Unless otherwise provided in the Contract Documents,

- .1 allowances shall cover the cost to the Contractor of materials and equipment delivered at the site and all required taxes, less applicable trade discounts;
- .2 Contractor's costs for unloading and handling at the site, labor, installation costs, overhead, profit, and other expenses contemplated for stated allowance amounts shall be included in the Contract Sum but not in the allowances; and
- .3 whenever costs are more than or less than allowances, the Contract Sum shall be adjusted accordingly by Change Order. The amount of the Change Order shall reflect (1) the difference between actual costs and the allowances under Section 3.8.2.1 and (2) changes in Contractor's costs under Section 3.8.2.2.

§ 3.8.3 Materials and equipment under an allowance shall be selected by the Owner with reasonable promptness.

§ 3.9 Superintendent

§ 3.9.1 The Contractor shall employ a competent superintendent and necessary assistants who shall be in attendance at the Project site during performance of the Work. The superintendent shall represent the Contractor, and communications given to the superintendent shall be as binding as if given to the Contractor.

§ 3.9.2 The Contractor, as soon as practicable after award of the Contract, shall notify the Owner and Architect of the name and qualifications of a proposed superintendent. Within 14 days of receipt of the information, the Architect may notify the Contractor, stating whether the Owner or the Architect (1) has reasonable objection to the proposed superintendent or (2) requires additional time for review. Failure of the Architect to provide notice within the 14-day period shall constitute notice of no reasonable objection.

§ 3.9.3 The Contractor shall not employ a proposed superintendent to whom the Owner or Architect has made reasonable and timely objection. The Contractor shall not change the superintendent without the Owner's consent, which shall not unreasonably be withheld or delayed.

§ 3.10 Contractor's Construction and Submittal Schedules

§ 3.10.1 The Contractor, promptly after being awarded the Contract, shall submit for the Owner's and Architect's information a Contractor's construction schedule for the Work. The schedule shall contain detail appropriate for the Project, including (1) the date of commencement of the Work, interim schedule milestone dates, and the date of Substantial Completion; (2) an apportionment of the Work by construction activity; and (3) the time required for completion of each portion of the Work. The schedule shall provide for the orderly progression of the Work to completion and shall not exceed time limits current under the Contract Documents. The schedule shall be revised at appropriate intervals as required by the conditions of the Work and Project.

§ 3.10.2 The Contractor, promptly after being awarded the Contract and thereafter as necessary to maintain a current submittal schedule, shall submit a submittal schedule for the Architect's approval. The Architect's approval shall not be unreasonably delayed or withheld. The submittal schedule shall (1) be coordinated with the Contractor's construction schedule, and (2) allow the Architect reasonable time to review submittals. If the Contractor fails to submit a submittal schedule, or fails to provide submittals in accordance with the approved submittal schedule, the Contractor shall not be entitled to any increase in Contract Sum or extension of Contract Time based on the time required for review of submittals.

§ 3.10.3 The Contractor shall perform the Work in general accordance with the most recent schedules submitted to the Owner and Architect.

§ 3.11 Documents and Samples at the Site

The Contractor shall make available, at the Project site, the Contract Documents, including Change Orders, Construction Change Directives, and other Modifications, in good order and marked currently to indicate field changes and selections made during construction, and the approved Shop Drawings, Product Data, Samples, and similar required submittals. These shall be in electronic form or paper copy, available to the Architect and Owner, and

delivered to the Architect for submittal to the Owner upon completion of the Work as a record of the Work as constructed.

§ 3.12 Shop Drawings, Product Data and Samples

§ 3.12.1 Shop Drawings are drawings, diagrams, schedules, and other data specially prepared for the Work by the Contractor or a Subcontractor, Sub-subcontractor, manufacturer, supplier, or distributor to illustrate some portion of the Work.

§ 3.12.2 Product Data are illustrations, standard schedules, performance charts, instructions, brochures, diagrams, and other information furnished by the Contractor to illustrate materials or equipment for some portion of the Work.

§ 3.12.3 Samples are physical examples that illustrate materials, equipment, or workmanship, and establish standards by which the Work will be judged.

§ 3.12.4 Shop Drawings, Product Data, Samples, and similar submittals are not Contract Documents. Their purpose is to demonstrate how the Contractor proposes to conform to the information given and the design concept expressed in the Contract Documents for those portions of the Work for which the Contract Documents require submittals. Review by the Architect is subject to the limitations of Section 4.2.7. Informational submittals upon which the Architect is not expected to take responsive action may be so identified in the Contract Documents. Submittals that are not required by the Contract Documents may be returned by the Architect without action.

§ 3.12.5 The Contractor shall review for compliance with the Contract Documents, approve, and submit to the Architect, Shop Drawings, Product Data, Samples, and similar submittals required by the Contract Documents, in accordance with the submittal schedule approved by the Architect or, in the absence of an approved submittal schedule, with reasonable promptness and in such sequence as to cause no delay in the Work or in the activities of the Owner or of Separate Contractors.

§ 3.12.6 By submitting Shop Drawings, Product Data, Samples, and similar submittals, the Contractor represents to the Owner and Architect that the Contractor has (1) reviewed and approved them, (2) determined and verified materials, field measurements and field construction criteria related thereto, or will do so, and (3) checked and coordinated the information contained within such submittals with the requirements of the Work and of the Contract Documents.

§ 3.12.7 The Contractor shall perform no portion of the Work for which the Contract Documents require submittal and review of Shop Drawings, Product Data, Samples, or similar submittals, until the respective submittal has been approved by the Architect.

§ 3.12.8 The Work shall be in accordance with approved submittals except that the Contractor shall not be relieved of responsibility for deviations from the requirements of the Contract Documents by the Architect's approval of Shop Drawings, Product Data, Samples, or similar submittals, unless the Contractor has specifically notified the Architect of such deviation at the time of submittal and (1) the Architect has given written approval to the specific deviation as a minor change in the Work, or (2) a Change Order or Construction Change Directive has been issued authorizing the deviation. The Contractor shall not be relieved of responsibility for errors or omissions in Shop Drawings, Product Data, Samples, or similar submittals, by the Architect's approval thereof.

§ 3.12.9 The Contractor shall direct specific attention, in writing or on resubmitted Shop Drawings, Product Data, Samples, or similar submittals, to revisions other than those requested by the Architect on previous submittals. In the absence of such notice, the Architect's approval of a resubmission shall not apply to such revisions.

§ 3.12.10 The Contractor shall not be required to provide professional services that constitute the practice of architecture or engineering unless such services are specifically required by the Contract Documents for a portion of the Work or unless the Contractor needs to provide such services in order to carry out the Contractor's responsibilities for construction means, methods, techniques, sequences, and procedures. The Contractor shall not be required to provide professional services in violation of applicable law.

§ 3.12.10.1 If professional design services or certifications by a design professional related to systems, materials, or equipment are specifically required of the Contractor by the Contract Documents, the Owner and the Architect will specify all performance and design criteria that such services must satisfy. The Contractor shall be entitled to rely

upon the adequacy and accuracy of the performance and design criteria provided in the Contract Documents. The Contractor shall cause such services or certifications to be provided by an appropriately licensed design professional, whose signature and seal shall appear on all drawings, calculations, specifications, certifications, Shop Drawings, and other submittals prepared by such professional. Shop Drawings, and other submittals related to the Work, designed or certified by such professional, if prepared by others, shall bear such professional's written approval when submitted to the Architect. The Owner and the Architect shall be entitled to rely upon the adequacy and accuracy of the services, certifications, and approvals performed or provided by such design professionals, provided the Owner and Architect have specified to the Contractor the performance and design criteria that such services must satisfy. Pursuant to this Section 3.12.10, the Architect will review and approve or take other appropriate action on submittals only for the limited purpose of checking for conformance with information given and the design concept expressed in the Contract Documents.

§ 3.12.10.2 If the Contract Documents require the Contractor's design professional to certify that the Work has been performed in accordance with the design criteria, the Contractor shall furnish such certifications to the Architect at the time and in the form specified by the Architect.

§ 3.13 Use of Site

The Contractor shall confine operations at the site to areas permitted by applicable laws, statutes, ordinances, codes, rules and regulations, lawful orders of public authorities, and the Contract Documents and shall not unreasonably encumber the site with materials or equipment.

§ 3.14 Cutting and Patching

§ 3.14.1 The Contractor shall be responsible for cutting, fitting, or patching required to complete the Work or to make its parts fit together properly. All areas requiring cutting, fitting, or patching shall be restored to the condition existing prior to the cutting, fitting, or patching, unless otherwise required by the Contract Documents.

§ 3.14.2 The Contractor shall not damage or endanger a portion of the Work or fully or partially completed construction of the Owner or Separate Contractors by cutting, patching, or otherwise altering such construction, or by excavation. The Contractor shall not cut or otherwise alter construction by the Owner or a Separate Contractor except with written consent of the Owner and of the Separate Contractor. Consent shall not be unreasonably withheld. The Contractor shall not unreasonably withhold, from the Owner or a Separate Contractor, its consent to cutting or otherwise altering the Work.

§ 3.15 Cleaning Up

§ 3.15.1 The Contractor shall keep the premises and surrounding area free from accumulation of waste materials and rubbish caused by operations under the Contract. At completion of the Work, the Contractor shall remove waste materials, rubbish, the Contractor's tools, construction equipment, machinery, and surplus materials from and about the Project.

§ 3.15.2 If the Contractor fails to clean up as provided in the Contract Documents, the Owner may do so and the Owner shall be entitled to reimbursement from the Contractor.

§ 3.16 Access to Work

The Contractor shall provide the Owner and Architect with access to the Work in preparation and progress wherever located.

§ 3.17 Royalties, Patents and Copyrights

The Contractor shall pay all royalties and license fees. The Contractor shall defend suits or claims for infringement of copyrights and patent rights and shall hold the Owner and Architect harmless from loss on account thereof, but shall not be responsible for defense or loss when a particular design, process, or product of a particular manufacturer or manufacturers is required by the Contract Documents, or where the copyright violations are contained in Drawings, Specifications, or other documents prepared by the Owner or Architect. However, if an infringement of a copyright or patent is discovered by, or made known to, the Contractor, the Contractor shall be responsible for the loss unless the information is promptly furnished to the Architect.

§ 3.18 Indemnification

§ 3.18.1 To the fullest extent permitted by law, the Contractor shall indemnify and hold harmless the Owner, Architect, Architect's consultants, and agents and employees of any of them from and against claims, damages, losses, and expenses, including but not limited to attorneys' fees, arising out of or resulting from performance of the Work, provided that such claim, damage, loss, or expense is attributable to bodily injury, sickness, disease or death, or to injury to or destruction of tangible property (other than the Work itself), but only to the extent caused by the negligent acts or omissions of the Contractor, a Subcontractor, anyone directly or indirectly employed by them, or anyone for whose acts they may be liable, regardless of whether or not such claim, damage, loss, or expense is caused in part by a party indemnified hereunder. Such obligation shall not be construed to negate, abridge, or reduce other rights or obligations of indemnity that would otherwise exist as to a party or person described in this Section 3.18.

§ 3.18.2 In claims against any person or entity indemnified under this Section 3.18 by an employee of the Contractor, a Subcontractor, anyone directly or indirectly employed by them, or anyone for whose acts they may be liable, the indemnification obligation under Section 3.18.1 shall not be limited by a limitation on amount or type of damages, compensation, or benefits payable by or for the Contractor or a Subcontractor under workers' compensation acts, disability benefit acts, or other employee benefit acts.

ARTICLE 4 ARCHITECT

§ 4.1 General

§ 4.1.1 The Architect is the person or entity retained by the Owner pursuant to Section 2.3.2 and identified as such in the Agreement.

§ 4.1.2 Duties, responsibilities, and limitations of authority of the Architect as set forth in the Contract Documents shall not be restricted, modified, or extended without written consent of the Owner, Contractor, and Architect. Consent shall not be unreasonably withheld.

§ 4.2 Administration of the Contract

§ 4.2.1 The Architect will provide administration of the Contract as described in the Contract Documents and will be an Owner's representative during construction until the date the Architect issues the final Certificate for Payment. The Architect will have authority to act on behalf of the Owner only to the extent provided in the Contract Documents.

§ 4.2.2 The Architect will visit the site at intervals appropriate to the stage of construction, or as otherwise agreed with the Owner, to become generally familiar with the progress and quality of the portion of the Work completed, and to determine in general if the Work observed is being performed in a manner indicating that the Work, when fully completed, will be in accordance with the Contract Documents. However, the Architect will not be required to make exhaustive or continuous on-site inspections to check the quality or quantity of the Work. The Architect will not have control over, charge of, or responsibility for the construction means, methods, techniques, sequences or procedures, or for the safety precautions and programs in connection with the Work, since these are solely the Contractor's rights and responsibilities under the Contract Documents.

§ 4.2.3 On the basis of the site visits, the Architect will keep the Owner reasonably informed about the progress and quality of the portion of the Work completed, and promptly report to the Owner (1) known deviations from the Contract Documents, (2) known deviations from the most recent construction schedule submitted by the Contractor, and (3) defects and deficiencies observed in the Work. The Architect will not be responsible for the Contractor's failure to perform the Work in accordance with the requirements of the Contract Documents. The Architect will not have control over or charge of, and will not be responsible for acts or omissions of, the Contractor, Subcontractors, or their agents or employees, or any other persons or entities performing portions of the Work.

§ 4.2.4 Communications

The Owner and Contractor shall include the Architect in all communications that relate to or affect the Architect's services or professional responsibilities. The Owner shall promptly notify the Architect of the substance of any direct communications between the Owner and the Contractor otherwise relating to the Project. Communications by and with the Architect's consultants shall be through the Architect. Communications by and with Subcontractors and suppliers shall be through the Contractor. Communications by and with Separate Contractors shall be through the Owner. The Contract Documents may specify other communication protocols.

§ 4.2.5 Based on the Architect's evaluations of the Contractor's Applications for Payment, the Architect will review and certify the amounts due the Contractor and will issue Certificates for Payment in such amounts.

§ 4.2.6 The Architect has authority to reject Work that does not conform to the Contract Documents. Whenever the Architect considers it necessary or advisable, the Architect will have authority to require inspection or testing of the Work in accordance with Sections 13.4.2 and 13.4.3, whether or not the Work is fabricated, installed or completed. However, neither this authority of the Architect nor a decision made in good faith either to exercise or not to exercise such authority shall give rise to a duty or responsibility of the Architect to the Contractor, Subcontractors, suppliers, their agents or employees, or other persons or entities performing portions of the Work.

§ 4.2.7 The Architect will review and approve, or take other appropriate action upon, the Contractor's submittals such as Shop Drawings, Product Data, and Samples, but only for the limited purpose of checking for conformance with information given and the design concept expressed in the Contract Documents. The Architect's action will be taken in accordance with the submittal schedule approved by the Architect or, in the absence of an approved submittal schedule, with reasonable promptness while allowing sufficient time in the Architect's professional judgment to permit adequate review. Review of such submittals is not conducted for the purpose of determining the accuracy and completeness of other details such as dimensions and quantities, or for substantiating instructions for installation or performance of equipment or systems, all of which remain the responsibility of the Contractor as required by the Contract Documents. The Architect's review of the Contractor's submittals shall not relieve the Contractor of the obligations under Sections 3.3, 3.5, and 3.12. The Architect's review shall not constitute approval of safety precautions or of any construction means, methods, techniques, sequences, or procedures. The Architect's approval of a specific item shall not indicate approval of an assembly of which the item is a component.

§ 4.2.8 The Architect will prepare Change Orders and Construction Change Directives, and may order minor changes in the Work as provided in Section 7.4. The Architect will investigate and make determinations and recommendations regarding concealed and unknown conditions as provided in Section 3.7.4.

§ 4.2.9 The Architect will conduct inspections to determine the date or dates of Substantial Completion and the date of final completion; issue Certificates of Substantial Completion pursuant to Section 9.8; receive and forward to the Owner, for the Owner's review and records, written warranties and related documents required by the Contract and assembled by the Contractor pursuant to Section 9.10; and issue a final Certificate for Payment pursuant to Section 9.10.

§ 4.2.10 If the Owner and Architect agree, the Architect will provide one or more Project representatives to assist in carrying out the Architect's responsibilities at the site. The Owner shall notify the Contractor of any change in the duties, responsibilities and limitations of authority of the Project representatives.

§ 4.2.11 The Architect will interpret and decide matters concerning performance under, and requirements of, the Contract Documents on written request of either the Owner or Contractor. The Architect's response to such requests will be made in writing within any time limits agreed upon or otherwise with reasonable promptness.

§ 4.2.12 Interpretations and decisions of the Architect will be consistent with the intent of, and reasonably inferable from, the Contract Documents and will be in writing or in the form of drawings. When making such interpretations and decisions, the Architect will endeavor to secure faithful performance by both Owner and Contractor, will not show partiality to either, and will not be liable for results of interpretations or decisions rendered in good faith.

§ 4.2.13 The Architect's decisions on matters relating to aesthetic effect will be final if consistent with the intent expressed in the Contract Documents.

§ 4.2.14 The Architect will review and respond to requests for information about the Contract Documents. The Architect's response to such requests will be made in writing within any time limits agreed upon or otherwise with reasonable promptness. If appropriate, the Architect will prepare and issue supplemental Drawings and Specifications in response to the requests for information.

ARTICLE 5 SUBCONTRACTORS

§ 5.1 Definitions

§ 5.1.1 A Subcontractor is a person or entity who has a direct contract with the Contractor to perform a portion of the Work at the site. The term "Subcontractor" is referred to throughout the Contract Documents as if singular in number and means a Subcontractor or an authorized representative of the Subcontractor. The term "Subcontractor" does not include a Separate Contractor or the subcontractors of a Separate Contractor.

§ 5.1.2 A Sub-subcontractor is a person or entity who has a direct or indirect contract with a Subcontractor to perform a portion of the Work at the site. The term "Sub-subcontractor" is referred to throughout the Contract Documents as if singular in number and means a Sub-subcontractor or an authorized representative of the Sub-subcontractor.

§ 5.2 Award of Subcontracts and Other Contracts for Portions of the Work

§ 5.2.1 Unless otherwise stated in the Contract Documents, the Contractor, as soon as practicable after award of the Contract, shall notify the Owner and Architect of the persons or entities proposed for each principal portion of the Work, including those who are to furnish materials or equipment fabricated to a special design. Within 14 days of receipt of the information, the Architect may notify the Contractor whether the Owner or the Architect (1) has reasonable objection to any such proposed person or entity or (2) requires additional time for review. Failure of the Architect to provide notice within the 14-day period shall constitute notice of no reasonable objection.

§ 5.2.2 The Contractor shall not contract with a proposed person or entity to whom the Owner or Architect has made reasonable and timely objection. The Contractor shall not be required to contract with anyone to whom the Contractor has made reasonable objection.

§ 5.2.3 If the Owner or Architect has reasonable objection to a person or entity proposed by the Contractor, the Contractor shall propose another to whom the Owner or Architect has no reasonable objection. If the proposed but rejected Subcontractor was reasonably capable of performing the Work, the Contract Sum and Contract Time shall be increased or decreased by the difference, if any, occasioned by such change, and an appropriate Change Order shall be issued before commencement of the substitute Subcontractor's Work. However, no increase in the Contract Sum or Contract Time shall be allowed for such change unless the Contractor has acted promptly and responsively in submitting names as required.

§ 5.2.4 The Contractor shall not substitute a Subcontractor, person, or entity for one previously selected if the Owner or Architect makes reasonable objection to such substitution.

§ 5.3 Subcontractual Relations

By appropriate written agreement, the Contractor shall require each Subcontractor, to the extent of the Work to be performed by the Subcontractor, to be bound to the Contractor by terms of the Contract Documents, and to assume toward the Contractor all the obligations and responsibilities, including the responsibility for safety of the Subcontractor's Work that the Contractor, by these Contract Documents, assumes toward the Owner and Architect. Each subcontract agreement shall preserve and protect the rights of the Owner and Architect under the Contract Documents with respect to the Work to be performed by the Subcontractor so that subcontracting thereof will not prejudice such rights, and shall allow to the Subcontractor, unless specifically provided otherwise in the subcontract agreement, the benefit of all rights, remedies, and redress against the Contractor that the Contractor, by the Contract Documents, has against the Owner. Where appropriate, the Contractor shall require each Subcontractor to enter into similar agreements with Sub-subcontractors. The Contractor shall make available to each proposed Subcontractor, prior to the execution of the subcontract agreement, copies of the Contract Documents to which the Subcontractor will be bound, and, upon written request of the Subcontractor, identify to the Subcontractor terms and conditions of the proposed subcontract agreement that may be at variance with the Contract Documents. Subcontractors will similarly make copies of applicable portions of such documents available to their respective proposed Sub-subcontractors.

§ 5.4 Contingent Assignment of Subcontracts

§ 5.4.1 Each subcontract agreement for a portion of the Work is assigned by the Contractor to the Owner, provided that

- .1 assignment is effective only after termination of the Contract by the Owner for cause pursuant to Section 14.2 and only for those subcontract agreements that the Owner accepts by notifying the Subcontractor and Contractor; and
- .2 assignment is subject to the prior rights of the surety, if any, obligated under bond relating to the Contract.

When the Owner accepts the assignment of a subcontract agreement, the Owner assumes the Contractor's rights and obligations under the subcontract.

§ 5.4.2 Upon such assignment, if the Work has been suspended for more than 30 days, the Subcontractor's compensation shall be equitably adjusted for increases in cost resulting from the suspension.

§ 5.4.3 Upon assignment to the Owner under this Section 5.4, the Owner may further assign the subcontract to a successor contractor or other entity. If the Owner assigns the subcontract to a successor contractor or other entity, the Owner shall nevertheless remain legally responsible for all of the successor contractor's obligations under the subcontract.

ARTICLE 6 CONSTRUCTION BY OWNER OR BY SEPARATE CONTRACTORS

§ 6.1 Owner's Right to Perform Construction and to Award Separate Contracts

§ 6.1.1 The term "Separate Contractor(s)" shall mean other contractors retained by the Owner under separate agreements. The Owner reserves the right to perform construction or operations related to the Project with the Owner's own forces, and with Separate Contractors retained under Conditions of the Contract substantially similar to those of this Contract, including those provisions of the Conditions of the Contract related to insurance and waiver of subrogation.

§ 6.1.2 When separate contracts are awarded for different portions of the Project or other construction or operations on the site, the term "Contractor" in the Contract Documents in each case shall mean the Contractor who executes each separate Owner-Contractor Agreement.

§ 6.1.3 The Owner shall provide for coordination of the activities of the Owner's own forces and of each Separate Contractor with the Work of the Contractor, who shall cooperate with them. The Contractor shall participate with any Separate Contractors and the Owner in reviewing their construction schedules. The Contractor shall make any revisions to its construction schedule deemed necessary after a joint review and mutual agreement. The construction schedules shall then constitute the schedules to be used by the Contractor, Separate Contractors, and the Owner until subsequently revised.

§ 6.1.4 Unless otherwise provided in the Contract Documents, when the Owner performs construction or operations related to the Project with the Owner's own forces or with Separate Contractors, the Owner or its Separate Contractors shall have the same obligations and rights that the Contractor has under the Conditions of the Contract, including, without excluding others, those stated in Article 3, this Article 6, and Articles 10, 11, and 12.

§ 6.2 Mutual Responsibility

§ 6.2.1 The Contractor shall afford the Owner and Separate Contractors reasonable opportunity for introduction and storage of their materials and equipment and performance of their activities, and shall connect and coordinate the Contractor's construction and operations with theirs as required by the Contract Documents.

§ 6.2.2 If part of the Contractor's Work depends for proper execution or results upon construction or operations by the Owner or a Separate Contractor, the Contractor shall, prior to proceeding with that portion of the Work, promptly notify the Architect of apparent discrepancies or defects in the construction or operations by the Owner or Separate Contractor that would render it unsuitable for proper execution and results of the Contractor's Work. Failure of the Contractor to notify the Architect of apparent discrepancies or defects prior to proceeding with the Work shall constitute an acknowledgment that the Owner's or Separate Contractor's completed or partially completed construction is fit and proper to receive the Contractor's Work. The Contractor shall not be responsible for discrepancies or defects in the construction or operations by the Owner or Separate Contractor that are not apparent.

§ 6.2.3 The Contractor shall reimburse the Owner for costs the Owner incurs that are payable to a Separate Contractor because of the Contractor's delays, improperly timed activities or defective construction. The Owner shall be responsible to the Contractor for costs the Contractor incurs because of a Separate Contractor's delays, improperly timed activities, damage to the Work or defective construction.

§ 6.2.4 The Contractor shall promptly remedy damage that the Contractor wrongfully causes to completed or partially completed construction or to property of the Owner or Separate Contractor as provided in Section 10.2.5.

Init.

§ 6.2.5 The Owner and each Separate Contractor shall have the same responsibilities for cutting and patching as are described for the Contractor in Section 3.14.

§ 6.3 Owner's Right to Clean Up

If a dispute arises among the Contractor, Separate Contractors, and the Owner as to the responsibility under their respective contracts for maintaining the premises and surrounding area free from waste materials and rubbish, the Owner may clean up and the Architect will allocate the cost among those responsible.

ARTICLE 7 CHANGES IN THE WORK

§ 7.1 General

§ 7.1.1 Changes in the Work may be accomplished after execution of the Contract, and without invalidating the Contract, by Change Order, Construction Change Directive or order for a minor change in the Work, subject to the limitations stated in this Article 7 and elsewhere in the Contract Documents.

§ 7.1.2 A Change Order shall be based upon agreement among the Owner, Contractor, and Architect. A Construction Change Directive requires agreement by the Owner and Architect and may or may not be agreed to by the Contractor. An order for a minor change in the Work may be issued by the Architect alone.

§ 7.1.3 Changes in the Work shall be performed under applicable provisions of the Contract Documents. The Contractor shall proceed promptly with changes in the Work, unless otherwise provided in the Change Order, Construction Change Directive, or order for a minor change in the Work.

§ 7.2 Change Orders

§ 7.2.1 A Change Order is a written instrument prepared by the Architect and signed by the Owner, Contractor, and Architect stating their agreement upon all of the following:

- .1 The change in the Work;
- .2 The amount of the adjustment, if any, in the Contract Sum; and
- .3 The extent of the adjustment, if any, in the Contract Time.

§ 7.3 Construction Change Directives

§ 7.3.1 A Construction Change Directive is a written order prepared by the Architect and signed by the Owner and Architect, directing a change in the Work prior to agreement on adjustment, if any, in the Contract Sum or Contract Time, or both. The Owner may by Construction Change Directive, without invalidating the Contract, order changes in the Work within the general scope of the Contract consisting of additions, deletions, or other revisions, the Contract Sum and Contract Time being adjusted accordingly.

§ 7.3.2 A Construction Change Directive shall be used in the absence of total agreement on the terms of a Change Order.

§ 7.3.3 If the Construction Change Directive provides for an adjustment to the Contract Sum, the adjustment shall be based on one of the following methods:

- .1 Mutual acceptance of a lump sum properly itemized and supported by sufficient substantiating data to permit evaluation;
- .2 Unit prices stated in the Contract Documents or subsequently agreed upon;
- .3 Cost to be determined in a manner agreed upon by the parties and a mutually acceptable fixed or percentage fee; or
- .4 As provided in Section 7.3.4.

§ 7.3.4 If the Contractor does not respond promptly or disagrees with the method for adjustment in the Contract Sum, the Architect shall determine the adjustment on the basis of reasonable expenditures and savings of those performing the Work attributable to the change, including, in case of an increase in the Contract Sum, an amount for overhead and profit as set forth in the Agreement, or if no such amount is set forth in the Agreement, a reasonable amount. In such case, and also under Section 7.3.3.3, the Contractor shall keep and present, in such form as the Architect may prescribe, an itemized accounting together with appropriate supporting data. Unless otherwise provided in the Contract Documents, costs for the purposes of this Section 7.3.4 shall be limited to the following:

- .1 Costs of labor, including applicable payroll taxes, fringe benefits required by agreement or custom, workers' compensation insurance, and other employee costs approved by the Architect;
- .2 Costs of materials, supplies, and equipment, including cost of transportation, whether incorporated or consumed;
- .3 Rental costs of machinery and equipment, exclusive of hand tools, whether rented from the Contractor or others;
- .4 Costs of premiums for all bonds and insurance, permit fees, and sales, use, or similar taxes, directly related to the change; and
- .5 Costs of supervision and field office personnel directly attributable to the change.

§ 7.3.5 If the Contractor disagrees with the adjustment in the Contract Time, the Contractor may make a Claim in accordance with applicable provisions of Article 15.

§ 7.3.6 Upon receipt of a Construction Change Directive, the Contractor shall promptly proceed with the change in the Work involved and advise the Architect of the Contractor's agreement or disagreement with the method, if any, provided in the Construction Change Directive for determining the proposed adjustment in the Contract Sum or Contract Time.

§ 7.3.7 A Construction Change Directive signed by the Contractor indicates the Contractor's agreement therewith, including adjustment in Contract Sum and Contract Time or the method for determining them. Such agreement shall be effective immediately and shall be recorded as a Change Order.

§ 7.3.8 The amount of credit to be allowed by the Contractor to the Owner for a deletion or change that results in a net decrease in the Contract Sum shall be actual net cost as confirmed by the Architect. When both additions and credits covering related Work or substitutions are involved in a change, the allowance for overhead and profit shall be figured on the basis of net increase, if any, with respect to that change.

§ 7.3.9 Pending final determination of the total cost of a Construction Change Directive to the Owner, the Contractor may request payment for Work completed under the Construction Change Directive in Applications for Payment. The Architect will make an interim determination for purposes of monthly certification for payment for those costs and certify for payment the amount that the Architect determines, in the Architect's professional judgment, to be reasonably justified. The Architect's interim determination of cost shall adjust the Contract Sum on the same basis as a Change Order, subject to the right of either party to disagree and assert a Claim in accordance with Article 15.

§ 7.3.10 When the Owner and Contractor agree with a determination made by the Architect concerning the adjustments in the Contract Sum and Contract Time, or otherwise reach agreement upon the adjustments, such agreement shall be effective immediately and the Architect will prepare a Change Order. Change Orders may be issued for all or any part of a Construction Change Directive.

§ 7.4 Minor Changes in the Work

The Architect may order minor changes in the Work that are consistent with the intent of the Contract Documents and do not involve an adjustment in the Contract Sum or an extension of the Contract Time. The Architect's order for minor changes shall be in writing. If the Contractor believes that the proposed minor change in the Work will affect the Contract Sum or Contract Time, the Contractor shall notify the Architect and shall not proceed to implement the change in the Work. If the Contractor performs the Work set forth in the Architect's order for a minor change without prior notice to the Architect that such change will affect the Contract Sum or Contract Time, the Contractor waives any adjustment to the Contract Sum or extension of the Contract Time.

ARTICLE 8 TIME

§ 8.1 Definitions

§ 8.1.1 Unless otherwise provided, Contract Time is the period of time, including authorized adjustments, allotted in the Contract Documents for Substantial Completion of the Work.

§ 8.1.2 The date of commencement of the Work is the date established in the Agreement.

§ 8.1.3 The date of Substantial Completion is the date certified by the Architect in accordance with Section 9.8.

§ 8.1.4 The term "day" as used in the Contract Documents shall mean calendar day unless otherwise specifically defined.

§ 8.2 Progress and Completion

§ 8.2.1 Time limits stated in the Contract Documents are of the essence of the Contract. By executing the Agreement, the Contractor confirms that the Contract Time is a reasonable period for performing the Work.

§ 8.2.2 The Contractor shall not knowingly, except by agreement or instruction of the Owner in writing, commence the Work prior to the effective date of insurance required to be furnished by the Contractor and Owner.

§ 8.2.3 The Contractor shall proceed expeditiously with adequate forces and shall achieve Substantial Completion within the Contract Time.

§ 8.3 Delays and Extensions of Time

§ 8.3.1 If the Contractor is delayed at any time in the commencement or progress of the Work by (1) an act or neglect of the Owner or Architect, of an employee of either, or of a Separate Contractor; (2) by changes ordered in the Work; (3) by labor disputes, fire, unusual delay in deliveries, unavoidable casualties, adverse weather conditions documented in accordance with Section 15.1.6.2, or other causes beyond the Contractor's control; (4) by delay authorized by the Owner pending mediation and binding dispute resolution; or (5) by other causes that the Contractor asserts, and the Architect determines, justify delay, then the Contract Time shall be extended for such reasonable time as the Architect may determine.

§ 8.3.2 Claims relating to time shall be made in accordance with applicable provisions of Article 15.

§ 8.3.3 This Section 8.3 does not preclude recovery of damages for delay by either party under other provisions of the Contract Documents.

ARTICLE 9 PAYMENTS AND COMPLETION

§ 9.1 Contract Sum

§ 9.1.1 The Contract Sum is stated in the Agreement and, including authorized adjustments, is the total amount payable by the Owner to the Contractor for performance of the Work under the Contract Documents.

§ 9.1.2 If unit prices are stated in the Contract Documents or subsequently agreed upon, and if quantities originally contemplated are materially changed so that application of such unit prices to the actual quantities causes substantial inequity to the Owner or Contractor, the applicable unit prices shall be equitably adjusted.

§ 9.2 Schedule of Values

Where the Contract is based on a stipulated sum or Guaranteed Maximum Price, the Contractor shall submit a schedule of values to the Architect before the first Application for Payment, allocating the entire Contract Sum to the various portions of the Work. The schedule of values shall be prepared in the form, and supported by the data to substantiate its accuracy, required by the Architect. This schedule, unless objected to by the Architect, shall be used as a basis for reviewing the Contractor's Applications for Payment. Any changes to the schedule of values shall be submitted to the Architect and supported by such data to substantiate its accuracy as the Architect may require, and unless objected to by the Architect, shall be used as a basis for reviewing the Contractor's subsequent Applications for Payment.

§ 9.3 Applications for Payment

§ 9.3.1 At least ten days before the date established for each progress payment, the Contractor shall submit to the Architect an itemized Application for Payment prepared in accordance with the schedule of values, if required under Section 9.2, for completed portions of the Work. The application shall be notarized, if required, and supported by all data substantiating the Contractor's right to payment that the Owner or Architect require, such as copies of requisitions, and releases and waivers of liens from Subcontractors and suppliers, and shall reflect retainage if provided for in the Contract Documents.

§ 9.3.1.1 As provided in Section 7.3.9, such applications may include requests for payment on account of changes in the Work that have been properly authorized by Construction Change Directives, or by interim determinations of the Architect, but not yet included in Change Orders.

Init.

§ 9.3.1.2 Applications for Payment shall not include requests for payment for portions of the Work for which the Contractor does not intend to pay a Subcontractor or supplier, unless such Work has been performed by others whom the Contractor intends to pay.

§ 9.3.2 Unless otherwise provided in the Contract Documents, payments shall be made on account of materials and equipment delivered and suitably stored at the site for subsequent incorporation in the Work. If approved in advance by the Owner, payment may similarly be made for materials and equipment suitably stored off the site at a location agreed upon in writing. Payment for materials and equipment stored on or off the site shall be conditioned upon compliance by the Contractor with procedures satisfactory to the Owner to establish the Owner's title to such materials and equipment or otherwise protect the Owner's interest, and shall include the costs of applicable insurance, storage, and transportation to the site, for such materials and equipment stored off the site.

§ 9.3.3 The Contractor warrants that title to all Work covered by an Application for Payment will pass to the Owner no later than the time of payment. The Contractor further warrants that upon submittal of an Application for Payment all Work for which Certificates for Payment have been previously issued and payments received from the Owner shall, to the best of the Contractor's knowledge, information, and belief, be free and clear of liens, claims, security interests, or encumbrances, in favor of the Contractor, Subcontractors, suppliers, or other persons or entities that provided labor, materials, and equipment relating to the Work.

§ 9.4 Certificates for Payment

§ 9.4.1 The Architect will, within seven days after receipt of the Contractor's Application for Payment, either (1) issue to the Owner a Certificate for Payment in the full amount of the Application for Payment, with a copy to the Contractor; or (2) issue to the Owner a Certificate for Payment for such amount as the Architect determines is properly due, and notify the Contractor and Owner of the Architect's reasons for withholding certification in part as provided in Section 9.5.1; or (3) withhold certification of the entire Application for Payment, and notify the Contractor and Owner of the Architect's reason for withholding certification in whole as provided in Section 9.5.1.

§ 9.4.2 The issuance of a Certificate for Payment will constitute a representation by the Architect to the Owner, based on the Architect's evaluation of the Work and the data in the Application for Payment, that, to the best of the Architect's knowledge, information, and belief, the Work has progressed to the point indicated, the quality of the Work is in accordance with the Contract Documents, and that the Contractor is entitled to payment in the amount certified. The foregoing representations are subject to an evaluation of the Work for conformance with the Contract Documents upon Substantial Completion, to results of subsequent tests and inspections, to correction of minor deviations from the Contract Documents prior to completion, and to specific qualifications expressed by the Architect. However, the issuance of a Certificate for Payment will not be a representation that the Architect has (1) made exhaustive or continuous on-site inspections to check the quality or quantity of the Work; (2) reviewed construction means, methods, techniques, sequences, or procedures; (3) reviewed copies of requisitions received from Subcontractors and suppliers and other data requested by the Owner to substantiate the Contractor's right to payment; or (4) made examination to ascertain how or for what purpose the Contractor has used money previously paid on account of the Contract Sum.

§ 9.5 Decisions to Withhold Certification

§ 9.5.1 The Architect may withhold a Certificate for Payment in whole or in part, to the extent reasonably necessary to protect the Owner, if in the Architect's opinion the representations to the Owner required by Section 9.4.2 cannot be made. If the Architect is unable to certify payment in the amount of the Application, the Architect will notify the Contractor and Owner as provided in Section 9.4.1. If the Contractor and Architect cannot agree on a revised amount, the Architect will promptly issue a Certificate for Payment for the amount for which the Architect is able to make such representations to the Owner. The Architect may also withhold a Certificate for Payment or, because of subsequently discovered evidence, may nullify the whole or a part of a Certificate for Payment previously issued, to such extent as may be necessary in the Architect's opinion to protect the Owner from loss for which the Contractor is responsible, including loss resulting from acts and omissions described in Section 3.3.2, because of

- .1 defective Work not remedied;
- .2 third party claims filed or reasonable evidence indicating probable filing of such claims, unless security acceptable to the Owner is provided by the Contractor;
- .3 failure of the Contractor to make payments properly to Subcontractors or suppliers for labor, materials or equipment;

- .4 reasonable evidence that the Work cannot be completed for the unpaid balance of the Contract Sum;
- .5 damage to the Owner or a Separate Contractor;
- .6 reasonable evidence that the Work will not be completed within the Contract Time, and that the unpaid balance would not be adequate to cover actual or liquidated damages for the anticipated delay; or
- .7 repeated failure to carry out the Work in accordance with the Contract Documents.

§ 9.5.2 When either party disputes the Architect's decision regarding a Certificate for Payment under Section 9.5.1, in whole or in part, that party may submit a Claim in accordance with Article 15.

§ 9.5.3 When the reasons for withholding certification are removed, certification will be made for amounts previously withheld.

§ 9.5.4 If the Architect withholds certification for payment under Section 9.5.1.3, the Owner may, at its sole option, issue joint checks to the Contractor and to any Subcontractor or supplier to whom the Contractor failed to make payment for Work properly performed or material or equipment suitably delivered. If the Owner makes payments by joint check, the Owner shall notify the Architect and the Contractor shall reflect such payment on its next Application for Payment.

§ 9.6 Progress Payments

§ 9.6.1 After the Architect has issued a Certificate for Payment, the Owner shall make payment in the manner and within the time provided in the Contract Documents, and shall so notify the Architect.

§ 9.6.2 The Contractor shall pay each Subcontractor, no later than seven days after receipt of payment from the Owner, the amount to which the Subcontractor is entitled, reflecting percentages actually retained from payments to the Contractor on account of the Subcontractor's portion of the Work. The Contractor shall, by appropriate agreement with each Subcontractor, require each Subcontractor to make payments to Sub-subcontractors in a similar manner.

§ 9.6.3 The Architect will, on request, furnish to a Subcontractor, if practicable, information regarding percentages of completion or amounts applied for by the Contractor and action taken thereon by the Architect and Owner on account of portions of the Work done by such Subcontractor.

§ 9.6.4 The Owner has the right to request written evidence from the Contractor that the Contractor has properly paid Subcontractors and suppliers amounts paid by the Owner to the Contractor for subcontracted Work. If the Contractor fails to furnish such evidence within seven days, the Owner shall have the right to contact Subcontractors and suppliers to ascertain whether they have been properly paid. Neither the Owner nor Architect shall have an obligation to pay, or to see to the payment of money to, a Subcontractor or supplier, except as may otherwise be required by law.

§ 9.6.5 The Contractor's payments to suppliers shall be treated in a manner similar to that provided in Sections 9.6.2, 9.6.3 and 9.6.4.

§ 9.6.6 A Certificate for Payment, a progress payment, or partial or entire use or occupancy of the Project by the Owner shall not constitute acceptance of Work not in accordance with the Contract Documents.

§ 9.6.7 Unless the Contractor provides the Owner with a payment bond in the full penal sum of the Contract Sum, payments received by the Contractor for Work properly performed by Subcontractors or provided by suppliers shall be held by the Contractor for those Subcontractors or suppliers who performed Work or furnished materials, or both, under contract with the Contractor for which payment was made by the Owner. Nothing contained herein shall require money to be placed in a separate account and not commingled with money of the Contractor, create any fiduciary liability or tort liability on the part of the Contractor for breach of trust, or entitle any person or entity to an award of punitive damages against the Contractor for breach of the requirements of this provision.

§ 9.6.8 Provided the Owner has fulfilled its payment obligations under the Contract Documents, the Contractor shall defend and indemnify the Owner from all loss, liability, damage or expense, including reasonable attorney's fees and litigation expenses, arising out of any lien claim or other claim for payment by any Subcontractor or supplier of any tier. Upon receipt of notice of a lien claim or other claim for payment, the Owner shall notify the Contractor. If approved by the applicable court, when required, the Contractor may substitute a surety bond for the property against which the lien or other claim for payment has been asserted.

§ 9.7 Failure of Payment

If the Architect does not issue a Certificate for Payment, through no fault of the Contractor, within seven days after receipt of the Contractor's Application for Payment, or if the Owner does not pay the Contractor within seven days after the date established in the Contract Documents, the amount certified by the Architect or awarded by binding dispute resolution, then the Contractor may, upon seven additional days' notice to the Owner and Architect, stop the Work until payment of the amount owing has been received. The Contract Time shall be extended appropriately and the Contract Sum shall be increased by the amount of the Contractor's reasonable costs of shutdown, delay and start-up, plus interest as provided for in the Contract Documents.

§ 9.8 Substantial Completion

§ 9.8.1 Substantial Completion is the stage in the progress of the Work when the Work or designated portion thereof is sufficiently complete in accordance with the Contract Documents so that the Owner can occupy or utilize the Work for its intended use.

§ 9.8.2 When the Contractor considers that the Work, or a portion thereof which the Owner agrees to accept separately, is substantially complete, the Contractor shall prepare and submit to the Architect a comprehensive list of items to be completed or corrected prior to final payment. Failure to include an item on such list does not alter the responsibility of the Contractor to complete all Work in accordance with the Contract Documents.

§ 9.8.3 Upon receipt of the Contractor's list, the Architect will make an inspection to determine whether the Work or designated portion thereof is substantially complete. If the Architect's inspection discloses any item, whether or not included on the Contractor's list, which is not sufficiently complete in accordance with the Contract Documents so that the Owner can occupy or utilize the Work or designated portion thereof for its intended use, the Contractor shall, before issuance of the Certificate of Substantial Completion, complete or correct such item upon notification by the Architect. In such case, the Contractor shall then submit a request for another inspection by the Architect to determine Substantial Completion.

§ 9.8.4 When the Work or designated portion thereof is substantially complete, the Architect will prepare a Certificate of Substantial Completion that shall establish the date of Substantial Completion; establish responsibilities of the Owner and Contractor for security, maintenance, heat, utilities, damage to the Work and insurance; and fix the time within which the Contractor shall finish all items on the list accompanying the Certificate. Warranties required by the Contract Documents shall commence on the date of Substantial Completion of the Work or designated portion thereof unless otherwise provided in the Certificate of Substantial Completion.

§ 9.8.5 The Certificate of Substantial Completion shall be submitted to the Owner and Contractor for their written acceptance of responsibilities assigned to them in the Certificate. Upon such acceptance, and consent of surety if any, the Owner shall make payment of retainage applying to the Work or designated portion thereof. Such payment shall be adjusted for Work that is incomplete or not in accordance with the requirements of the Contract Documents.

§ 9.9 Partial Occupancy or Use

§ 9.9.1 The Owner may occupy or use any completed or partially completed portion of the Work at any stage when such portion is designated by separate agreement with the Contractor, provided such occupancy or use is consented to by the insurer and authorized by public authorities having jurisdiction over the Project. Such partial occupancy or use may commence whether or not the portion is substantially complete, provided the Owner and Contractor have accepted in writing the responsibilities assigned to each of them for payments, retainage, if any, security, maintenance, heat, utilities, damage to the Work and insurance, and have agreed in writing concerning the period for correction of the Work and commencement of warranties required by the Contract Documents. When the Contractor considers a portion substantially complete, the Contractor shall prepare and submit a list to the Architect as provided under Section 9.8.2. Consent of the Contractor to partial occupancy or use shall not be unreasonably withheld. The stage of the progress of the Work shall be determined by written agreement between the Owner and Contractor or, if no agreement is reached, by decision of the Architect.

§ 9.9.2 Immediately prior to such partial occupancy or use, the Owner, Contractor, and Architect shall jointly inspect the area to be occupied or portion of the Work to be used in order to determine and record the condition of the Work.

§ 9.9.3 Unless otherwise agreed upon, partial occupancy or use of a portion or portions of the Work shall not constitute acceptance of Work not complying with the requirements of the Contract Documents.

§ 9.10 Final Completion and Final Payment

§ 9.10.1 Upon receipt of the Contractor's notice that the Work is ready for final inspection and acceptance and upon receipt of a final Application for Payment, the Architect will promptly make such inspection. When the Architect finds the Work acceptable under the Contract Documents and the Contract fully performed, the Architect will promptly issue a final Certificate for Payment stating that to the best of the Architect's knowledge, information and belief, and on the basis of the Architect's on-site visits and inspections, the Work has been completed in accordance with the Contract Documents and that the entire balance found to be due the Contractor and noted in the final Certificate is due and payable. The Architect's final Certificate for Payment will constitute a further representation that conditions listed in Section 9.10.2 as precedent to the Contractor's being entitled to final payment have been fulfilled.

§ 9.10.2 Neither final payment nor any remaining retained percentage shall become due until the Contractor submits to the Architect (1) an affidavit that payrolls, bills for materials and equipment, and other indebtedness connected with the Work for which the Owner or the Owner's property might be responsible or encumbered (less amounts withheld by Owner) have been paid or otherwise satisfied, (2) a certificate evidencing that insurance required by the Contract Documents to remain in force after final payment is currently in effect, (3) a written statement that the Contractor knows of no reason that the insurance will not be renewable to cover the period required by the Contract Documents, (4) consent of surety, if any, to final payment, (5) documentation of any special warranties, such as manufacturers' warranties or specific Subcontractor warranties, and (6) if required by the Owner, other data establishing payment or satisfaction of obligations, such as receipts and releases and waivers of liens, claims, security interests, or encumbrances arising out of the Contract, to the extent and in such form as may be designated by the Owner. If a Subcontractor refuses to furnish a release or waiver required by the Owner, the Contractor may furnish a bond satisfactory to the Owner to indemnify the Owner against such lien, claim, security interest, or encumbrance. If a lien, claim, security interest, or encumbrance remains unsatisfied after payments are made, the Contractor shall refund to the Owner all money that the Owner may be compelled to pay in discharging the lien, claim, security interest, or encumbrance, including all costs and reasonable attorneys' fees.

§ 9.10.3 If, after Substantial Completion of the Work, final completion thereof is materially delayed through no fault of the Contractor or by issuance of Change Orders affecting final completion, and the Architect so confirms, the Owner shall, upon application by the Contractor and certification by the Architect, and without terminating the Contract, make payment of the balance due for that portion of the Work fully completed, corrected, and accepted. If the remaining balance for Work not fully completed or corrected is less than retainage stipulated in the Contract Documents, and if bonds have been furnished, the written consent of the surety to payment of the balance due for that portion of the Work fully completed and accepted shall be submitted by the Contractor to the Architect prior to certification of such payment. Such payment shall be made under terms and conditions governing final payment, except that it shall not constitute a waiver of Claims.

§ 9.10.4 The making of final payment shall constitute a waiver of Claims by the Owner except those arising from

- .1 liens, Claims, security interests, or encumbrances arising out of the Contract and unsettled;
- .2 failure of the Work to comply with the requirements of the Contract Documents;
- .3 terms of special warranties required by the Contract Documents; or
- .4 audits performed by the Owner, if permitted by the Contract Documents, after final payment.

§ 9.10.5 Acceptance of final payment by the Contractor, a Subcontractor, or a supplier, shall constitute a waiver of claims by that payee except those previously made in writing and identified by that payee as unsettled at the time of final Application for Payment.

ARTICLE 10 PROTECTION OF PERSONS AND PROPERTY

§ 10.1 Safety Precautions and Programs

The Contractor shall be responsible for initiating, maintaining, and supervising all safety precautions and programs in connection with the performance of the Contract.

§ 10.2 Safety of Persons and Property

§ 10.2.1 The Contractor shall take reasonable precautions for safety of, and shall provide reasonable protection to prevent damage, injury, or loss to

Init.

- .1 employees on the Work and other persons who may be affected thereby;
- .2 the Work and materials and equipment to be incorporated therein, whether in storage on or off the site, under care, custody, or control of the Contractor, a Subcontractor, or a Sub-subcontractor; and
- .3 other property at the site or adjacent thereto, such as trees, shrubs, lawns, walks, pavements, roadways, structures, and utilities not designated for removal, relocation, or replacement in the course of construction.

§ 10.2.2 The Contractor shall comply with, and give notices required by applicable laws, statutes, ordinances, codes, rules and regulations, and lawful orders of public authorities, bearing on safety of persons or property or their protection from damage, injury, or loss.

§ 10.2.3 The Contractor shall implement, erect, and maintain, as required by existing conditions and performance of the Contract, reasonable safeguards for safety and protection, including posting danger signs and other warnings against hazards; promulgating safety regulations; and notifying the owners and users of adjacent sites and utilities of the safeguards.

§ 10.2.4 When use or storage of explosives or other hazardous materials or equipment, or unusual methods are necessary for execution of the Work, the Contractor shall exercise utmost care and carry on such activities under supervision of properly qualified personnel.

§ 10.2.5 The Contractor shall promptly remedy damage and loss (other than damage or loss insured under property insurance required by the Contract Documents) to property referred to in Sections 10.2.1.2 and 10.2.1.3 caused in whole or in part by the Contractor, a Subcontractor, a Sub-subcontractor, or anyone directly or indirectly employed by any of them, or by anyone for whose acts they may be liable and for which the Contractor is responsible under Sections 10.2.1.2 and 10.2.1.3. The Contractor may make a Claim for the cost to remedy the damage or loss to the extent such damage or loss is attributable to acts or omissions of the Owner or Architect or anyone directly or indirectly employed by either of them, or by anyone for whose acts either of them may be liable, and not attributable to the fault or negligence of the Contractor. The foregoing obligations of the Contractor are in addition to the Contractor's obligations under Section 3.18.

§ 10.2.6 The Contractor shall designate a responsible member of the Contractor's organization at the site whose duty shall be the prevention of accidents. This person shall be the Contractor's superintendent unless otherwise designated by the Contractor in writing to the Owner and Architect.

§ 10.2.7 The Contractor shall not permit any part of the construction or site to be loaded so as to cause damage or create an unsafe condition.

§ 10.2.8 Injury or Damage to Person or Property

If either party suffers injury or damage to person or property because of an act or omission of the other party, or of others for whose acts such party is legally responsible, notice of the injury or damage, whether or not insured, shall be given to the other party within a reasonable time not exceeding 21 days after discovery. The notice shall provide sufficient detail to enable the other party to investigate the matter.

§ 10.3 Hazardous Materials and Substances

§ 10.3.1 The Contractor is responsible for compliance with any requirements included in the Contract Documents regarding hazardous materials or substances. If the Contractor encounters a hazardous material or substance not addressed in the Contract Documents and if reasonable precautions will be inadequate to prevent foreseeable bodily injury or death to persons resulting from a material or substance, including but not limited to asbestos or polychlorinated biphenyl (PCB), encountered on the site by the Contractor, the Contractor shall, upon recognizing the condition, immediately stop Work in the affected area and notify the Owner and Architect of the condition.

§ 10.3.2 Upon receipt of the Contractor's notice, the Owner shall obtain the services of a licensed laboratory to verify the presence or absence of the material or substance reported by the Contractor and, in the event such material or substance is found to be present, to cause it to be rendered harmless. Unless otherwise required by the Contract Documents, the Owner shall furnish in writing to the Contractor and Architect the names and qualifications of persons or entities who are to perform tests verifying the presence or absence of the material or substance or who are to perform the task of removal or safe containment of the material or substance. The Contractor and the Architect will

promptly reply to the Owner in writing stating whether or not either has reasonable objection to the persons or entities proposed by the Owner. If either the Contractor or Architect has an objection to a person or entity proposed by the Owner, the Owner shall propose another to whom the Contractor and the Architect have no reasonable objection. When the material or substance has been rendered harmless, Work in the affected area shall resume upon written agreement of the Owner and Contractor. By Change Order, the Contract Time shall be extended appropriately and the Contract Sum shall be increased by the amount of the Contractor's reasonable additional costs of shutdown, delay, and start-up.

§ 10.3.3 To the fullest extent permitted by law, the Owner shall indemnify and hold harmless the Contractor, Subcontractors, Architect, Architect's consultants, and agents and employees of any of them from and against claims, damages, losses, and expenses, including but not limited to attorneys' fees, arising out of or resulting from performance of the Work in the affected area if in fact the material or substance presents the risk of bodily injury or death as described in Section 10.3.1 and has not been rendered harmless, provided that such claim, damage, loss, or expense is attributable to bodily injury, sickness, disease or death, or to injury to or destruction of tangible property (other than the Work itself), except to the extent that such damage, loss, or expense is due to the fault or negligence of the party seeking indemnity.

§ 10.3.4 The Owner shall not be responsible under this Section 10.3 for hazardous materials or substances the Contractor brings to the site unless such materials or substances are required by the Contract Documents. The Owner shall be responsible for hazardous materials or substances required by the Contract Documents, except to the extent of the Contractor's fault or negligence in the use and handling of such materials or substances.

§ 10.3.5 The Contractor shall reimburse the Owner for the cost and expense the Owner incurs (1) for remediation of hazardous materials or substances the Contractor brings to the site and negligently handles, or (2) where the Contractor fails to perform its obligations under Section 10.3.1, except to the extent that the cost and expense are due to the Owner's fault or negligence.

§ 10.3.6 If, without negligence on the part of the Contractor, the Contractor is held liable by a government agency for the cost of remediation of a hazardous material or substance solely by reason of performing Work as required by the Contract Documents, the Owner shall reimburse the Contractor for all cost and expense thereby incurred.

§ 10.4 Emergencies

In an emergency affecting safety of persons or property, the Contractor shall act, at the Contractor's discretion, to prevent threatened damage, injury, or loss. Additional compensation or extension of time claimed by the Contractor on account of an emergency shall be determined as provided in Article 15 and Article 7.

ARTICLE 11 INSURANCE AND BONDS

§ 11.1 Contractor's Insurance and Bonds

§ 11.1.1 The Contractor shall purchase and maintain insurance of the types and limits of liability, containing the endorsements, and subject to the terms and conditions, as described in the Agreement or elsewhere in the Contract Documents. The Contractor shall purchase and maintain the required insurance from an insurance company or insurance companies lawfully authorized to issue insurance in the jurisdiction where the Project is located. The Owner, Architect, and Architect's consultants shall be named as additional insureds under the Contractor's commercial general liability policy or as otherwise described in the Contract Documents.

§ 11.1.2 The Contractor shall provide surety bonds of the types, for such penal sums, and subject to such terms and conditions as required by the Contract Documents. The Contractor shall purchase and maintain the required bonds from a company or companies lawfully authorized to issue surety bonds in the jurisdiction where the Project is located.

§ 11.1.3 Upon the request of any person or entity appearing to be a potential beneficiary of bonds covering payment of obligations arising under the Contract, the Contractor shall promptly furnish a copy of the bonds or shall authorize a copy to be furnished.

§ 11.1.4 Notice of Cancellation or Expiration of Contractor's Required Insurance. Within three (3) business days of the date the Contractor becomes aware of an impending or actual cancellation or expiration of any insurance required by the Contract Documents, the Contractor shall provide notice to the Owner of such impending or actual cancellation or

expiration. Upon receipt of notice from the Contractor, the Owner shall, unless the lapse in coverage arises from an act or omission of the Owner, have the right to stop the Work until the lapse in coverage has been cured by the procurement of replacement coverage by the Contractor. The furnishing of notice by the Contractor shall not relieve the Contractor of any contractual obligation to provide any required coverage.

§ 11.2 Owner's Insurance

§ 11.2.1 The Owner shall purchase and maintain insurance of the types and limits of liability, containing the endorsements, and subject to the terms and conditions, as described in the Agreement or elsewhere in the Contract Documents. The Owner shall purchase and maintain the required insurance from an insurance company or insurance companies lawfully authorized to issue insurance in the jurisdiction where the Project is located.

§ 11.2.2 Failure to Purchase Required Property Insurance. If the Owner fails to purchase and maintain the required property insurance, with all of the coverages and in the amounts described in the Agreement or elsewhere in the Contract Documents, the Owner shall inform the Contractor in writing prior to commencement of the Work. Upon receipt of notice from the Owner, the Contractor may delay commencement of the Work and may obtain insurance that will protect the interests of the Contractor, Subcontractors, and Sub-Subcontractors in the Work. When the failure to provide coverage has been cured or resolved, the Contract Sum and Contract Time shall be equitably adjusted. In the event the Owner fails to procure coverage, the Owner waives all rights against the Contractor, Subcontractors, and Sub-subcontractors to the extent the loss to the Owner would have been covered by the insurance to have been procured by the Owner. The cost of the insurance shall be charged to the Owner by a Change Order. If the Owner does not provide written notice, and the Contractor is damaged by the failure or neglect of the Owner to purchase or maintain the required insurance, the Owner shall reimburse the Contractor for all reasonable costs and damages attributable thereto.

§ 11.2.3 Notice of Cancellation or Expiration of Owner's Required Property Insurance. Within three (3) business days of the date the Owner becomes aware of an impending or actual cancellation or expiration of any property insurance required by the Contract Documents, the Owner shall provide notice to the Contractor of such impending or actual cancellation or expiration. Unless the lapse in coverage arises from an act or omission of the Contractor: (1) the Contractor, upon receipt of notice from the Owner, shall have the right to stop the Work until the lapse in coverage has been cured by the procurement of replacement coverage by either the Owner or the Contractor; (2) the Contract Time and Contract Sum shall be equitably adjusted; and (3) the Owner waives all rights against the Contractor, Subcontractors, and Sub-subcontractors to the extent any loss to the Owner would have been covered by the insurance had it not expired or been cancelled. If the Contractor purchases replacement coverage, the cost of the insurance shall be charged to the Owner by an appropriate Change Order. The furnishing of notice by the Owner shall not relieve the Owner of any contractual obligation to provide required insurance.

§ 11.3 Waivers of Subrogation

§ 11.3.1 The Owner and Contractor waive all rights against (1) each other and any of their subcontractors, sub-subcontractors, agents, and employees, each of the other; (2) the Architect and Architect's consultants; and (3) Separate Contractors, if any, and any of their subcontractors, sub-subcontractors, agents, and employees, for damages caused by fire, or other causes of loss, to the extent those losses are covered by property insurance required by the Agreement or other property insurance applicable to the Project, except such rights as they have to proceeds of such insurance. The Owner or Contractor, as appropriate, shall require similar written waivers in favor of the individuals and entities identified above from the Architect, Architect's consultants, Separate Contractors, subcontractors, and sub-subcontractors. The policies of insurance purchased and maintained by each person or entity agreeing to waive claims pursuant to this section 11.3.1 shall not prohibit this waiver of subrogation. This waiver of subrogation shall be effective as to a person or entity (1) even though that person or entity would otherwise have a duty of indemnification, contractual or otherwise, (2) even though that person or entity did not pay the insurance premium directly or indirectly, or (3) whether or not the person or entity had an insurable interest in the damaged property.

§ 11.3.2 If during the Project construction period the Owner insures properties, real or personal or both, at or adjacent to the site by property insurance under policies separate from those insuring the Project, or if after final payment property insurance is to be provided on the completed Project through a policy or policies other than those insuring the Project during the construction period, to the extent permissible by such policies, the Owner waives all rights in accordance with the terms of Section 11.3.1 for damages caused by fire or other causes of loss covered by this separate property insurance.

§ 11.4 Loss of Use, Business Interruption, and Delay in Completion Insurance

The Owner, at the Owner's option, may purchase and maintain insurance that will protect the Owner against loss of use of the Owner's property, or the inability to conduct normal operations, due to fire or other causes of loss. The Owner waives all rights of action against the Contractor and Architect for loss of use of the Owner's property, due to fire or other hazards however caused.

§11.5 Adjustment and Settlement of Insured Loss

§ 11.5.1 A loss insured under the property insurance required by the Agreement shall be adjusted by the Owner as fiduciary and made payable to the Owner as fiduciary for the insureds, as their interests may appear, subject to requirements of any applicable mortgagee clause and of Section 11.5.2. The Owner shall pay the Architect and Contractor their just shares of insurance proceeds received by the Owner, and by appropriate agreements the Architect and Contractor shall make payments to their consultants and Subcontractors in similar manner.

§ 11.5.2 Prior to settlement of an insured loss, the Owner shall notify the Contractor of the terms of the proposed settlement as well as the proposed allocation of the insurance proceeds. The Contractor shall have 14 days from receipt of notice to object to the proposed settlement or allocation of the proceeds. If the Contractor does not object, the Owner shall settle the loss and the Contractor shall be bound by the settlement and allocation. Upon receipt, the Owner shall deposit the insurance proceeds in a separate account and make the appropriate distributions. Thereafter, if no other agreement is made or the Owner does not terminate the Contract for convenience, the Owner and Contractor shall execute a Change Order for reconstruction of the damaged or destroyed Work in the amount allocated for that purpose. If the Contractor timely objects to either the terms of the proposed settlement or the allocation of the proceeds, the Owner may proceed to settle the insured loss, and any dispute between the Owner and Contractor arising out of the settlement or allocation of the proceeds shall be resolved pursuant to Article 15. Pending resolution of any dispute, the Owner may issue a Construction Change Directive for the reconstruction of the damaged or destroyed Work.

ARTICLE 12 UNCOVERING AND CORRECTION OF WORK

§ 12.1 Uncovering of Work

§ 12.1.1 If a portion of the Work is covered contrary to the Architect's request or to requirements specifically expressed in the Contract Documents, it must, if requested in writing by the Architect, be uncovered for the Architect's examination and be replaced at the Contractor's expense without change in the Contract Time.

§ 12.1.2 If a portion of the Work has been covered that the Architect has not specifically requested to examine prior to its being covered, the Architect may request to see such Work and it shall be uncovered by the Contractor. If such Work is in accordance with the Contract Documents, the Contractor shall be entitled to an equitable adjustment to the Contract Sum and Contract Time as may be appropriate. If such Work is not in accordance with the Contract Documents, the costs of uncovering the Work, and the cost of correction, shall be at the Contractor's expense.

§ 12.2 Correction of Work

§ 12.2.1 Before Substantial Completion

The Contractor shall promptly correct Work rejected by the Architect or failing to conform to the requirements of the Contract Documents, discovered before Substantial Completion and whether or not fabricated, installed or completed. Costs of correcting such rejected Work, including additional testing and inspections, the cost of uncovering and replacement, and compensation for the Architect's services and expenses made necessary thereby, shall be at the Contractor's expense.

§ 12.2.2 After Substantial Completion

§ 12.2.2.1 In addition to the Contractor's obligations under Section 3.5, if, within one year after the date of Substantial Completion of the Work or designated portion thereof or after the date for commencement of warranties established under Section 9.9.1, or by terms of any applicable special warranty required by the Contract Documents, any of the Work is found to be not in accordance with the requirements of the Contract Documents, the Contractor shall correct it promptly after receipt of notice from the Owner to do so, unless the Owner has previously given the Contractor a written acceptance of such condition. The Owner shall give such notice promptly after discovery of the condition. During the one-year period for correction of Work, if the Owner fails to notify the Contractor and give the Contractor an opportunity to make the correction, the Owner waives the rights to require correction by the Contractor and to make a claim for breach of warranty. If the Contractor fails to correct nonconforming Work within a reasonable time during

that period after receipt of notice from the Owner or Architect, the Owner may correct it in accordance with Section 2.5.

§ 12.2.2.2 The one-year period for correction of Work shall be extended with respect to portions of Work first performed after Substantial Completion by the period of time between Substantial Completion and the actual completion of that portion of the Work.

§ 12.2.2.3 The one-year period for correction of Work shall not be extended by corrective Work performed by the Contractor pursuant to this Section 12.2.

§ 12.2.3 The Contractor shall remove from the site portions of the Work that are not in accordance with the requirements of the Contract Documents and are neither corrected by the Contractor nor accepted by the Owner.

§ 12.2.4 The Contractor shall bear the cost of correcting destroyed or damaged construction of the Owner or Separate Contractors, whether completed or partially completed, caused by the Contractor's correction or removal of Work that is not in accordance with the requirements of the Contract Documents.

§ 12.2.5 Nothing contained in this Section 12.2 shall be construed to establish a period of limitation with respect to other obligations the Contractor has under the Contract Documents. Establishment of the one-year period for correction of Work as described in Section 12.2.2 relates only to the specific obligation of the Contractor to correct the Work, and has no relationship to the time within which the obligation to comply with the Contract Documents may be sought to be enforced, nor to the time within which proceedings may be commenced to establish the Contractor's liability with respect to the Contractor's obligations other than specifically to correct the Work.

§ 12.3 Acceptance of Nonconforming Work

If the Owner prefers to accept Work that is not in accordance with the requirements of the Contract Documents, the Owner may do so instead of requiring its removal and correction, in which case the Contract Sum will be reduced as appropriate and equitable. Such adjustment shall be effected whether or not final payment has been made.

ARTICLE 13 MISCELLANEOUS PROVISIONS

§ 13.1 Governing Law

The Contract shall be governed by the law of the place where the Project is located, excluding that jurisdiction's choice of law rules. If the parties have selected arbitration as the method of binding dispute resolution, the Federal Arbitration Act shall govern Section 15.4.

§ 13.2 Successors and Assigns

§ 13.2.1 The Owner and Contractor respectively bind themselves, their partners, successors, assigns, and legal representatives to covenants, agreements, and obligations contained in the Contract Documents. Except as provided in Section 13.2.2, neither party to the Contract shall assign the Contract as a whole without written consent of the other. If either party attempts to make an assignment without such consent, that party shall nevertheless remain legally responsible for all obligations under the Contract.

§ 13.2.2 The Owner may, without consent of the Contractor, assign the Contract to a lender providing construction financing for the Project, if the lender assumes the Owner's rights and obligations under the Contract Documents. The Contractor shall execute all consents reasonably required to facilitate the assignment.

§ 13.3 Rights and Remedies

§ 13.3.1 Duties and obligations imposed by the Contract Documents and rights and remedies available thereunder shall be in addition to and not a limitation of duties, obligations, rights, and remedies otherwise imposed or available by law.

§ 13.3.2 No action or failure to act by the Owner, Architect, or Contractor shall constitute a waiver of a right or duty afforded them under the Contract, nor shall such action or failure to act constitute approval of or acquiescence in a breach thereunder, except as may be specifically agreed upon in writing.

§ 13.4 Tests and Inspections

§ 13.4.1 Tests, inspections, and approvals of portions of the Work shall be made as required by the Contract Documents and by applicable laws, statutes, ordinances, codes, rules, and regulations or lawful orders of public authorities. Unless otherwise provided, the Contractor shall make arrangements for such tests, inspections, and approvals with an independent testing laboratory or entity acceptable to the Owner, or with the appropriate public authority, and shall bear all related costs of tests, inspections, and approvals. The Contractor shall give the Architect timely notice of when and where tests and inspections are to be made so that the Architect may be present for such procedures. The Owner shall bear costs of tests, inspections, or approvals that do not become requirements until after bids are received or negotiations concluded. The Owner shall directly arrange and pay for tests, inspections, or approvals where building codes or applicable laws or regulations so require.

§ 13.4.2 If the Architect, Owner, or public authorities having jurisdiction determine that portions of the Work require additional testing, inspection, or approval not included under Section 13.4.1, the Architect will, upon written authorization from the Owner, instruct the Contractor to make arrangements for such additional testing, inspection, or approval, by an entity acceptable to the Owner, and the Contractor shall give timely notice to the Architect of when and where tests and inspections are to be made so that the Architect may be present for such procedures. Such costs, except as provided in Section 13.4.3, shall be at the Owner's expense.

§ 13.4.3 If procedures for testing, inspection, or approval under Sections 13.4.1 and 13.4.2 reveal failure of the portions of the Work to comply with requirements established by the Contract Documents, all costs made necessary by such failure, including those of repeated procedures and compensation for the Architect's services and expenses, shall be at the Contractor's expense.

§ 13.4.4 Required certificates of testing, inspection, or approval shall, unless otherwise required by the Contract Documents, be secured by the Contractor and promptly delivered to the Architect.

§ 13.4.5 If the Architect is to observe tests, inspections, or approvals required by the Contract Documents, the Architect will do so promptly and, where practicable, at the normal place of testing.

§ 13.4.6 Tests or inspections conducted pursuant to the Contract Documents shall be made promptly to avoid unreasonable delay in the Work.

§ 13.5 Interest

Payments due and unpaid under the Contract Documents shall bear interest from the date payment is due at the rate the parties agree upon in writing or, in the absence thereof, at the legal rate prevailing from time to time at the place where the Project is located.

ARTICLE 14 TERMINATION OR SUSPENSION OF THE CONTRACT

§ 14.1 Termination by the Contractor

§ 14.1.1 The Contractor may terminate the Contract if the Work is stopped for a period of 30 consecutive days through no act or fault of the Contractor, a Subcontractor, a Sub-subcontractor, their agents or employees, or any other persons or entities performing portions of the Work, for any of the following reasons:

- .1 Issuance of an order of a court or other public authority having jurisdiction that requires all Work to be stopped;
- .2 An act of government, such as a declaration of national emergency, that requires all Work to be stopped;
- .3 Because the Architect has not issued a Certificate for Payment and has not notified the Contractor of the reason for withholding certification as provided in Section 9.4.1, or because the Owner has not made payment on a Certificate for Payment within the time stated in the Contract Documents; or
- .4 The Owner has failed to furnish to the Contractor reasonable evidence as required by Section 2.2.

§ 14.1.2 The Contractor may terminate the Contract if, through no act or fault of the Contractor, a Subcontractor, a Sub-subcontractor, their agents or employees, or any other persons or entities performing portions of the Work, repeated suspensions, delays, or interruptions of the entire Work by the Owner as described in Section 14.3, constitute in the aggregate more than 100 percent of the total number of days scheduled for completion, or 120 days in any 365-day period, whichever is less.

§ 14.1.3 If one of the reasons described in Section 14.1.1 or 14.1.2 exists, the Contractor may, upon seven days' notice to the Owner and Architect, terminate the Contract and recover from the Owner payment for Work executed, as well as reasonable overhead and profit on Work not executed, and costs incurred by reason of such termination.

§ 14.1.4 If the Work is stopped for a period of 60 consecutive days through no act or fault of the Contractor, a Subcontractor, a Sub-subcontractor, or their agents or employees or any other persons or entities performing portions of the Work because the Owner has repeatedly failed to fulfill the Owner's obligations under the Contract Documents with respect to matters important to the progress of the Work, the Contractor may, upon seven additional days' notice to the Owner and the Architect, terminate the Contract and recover from the Owner as provided in Section 14.1.3.

§ 14.2 Termination by the Owner for Cause

§ 14.2.1 The Owner may terminate the Contract if the Contractor

- .1 repeatedly refuses or fails to supply enough properly skilled workers or proper materials;
- .2 fails to make payment to Subcontractors or suppliers in accordance with the respective agreements between the Contractor and the Subcontractors or suppliers;
- .3 repeatedly disregards applicable laws, statutes, ordinances, codes, rules and regulations, or lawful orders of a public authority; or
- .4 otherwise is guilty of substantial breach of a provision of the Contract Documents.

§ 14.2.2 When any of the reasons described in Section 14.2.1 exist, and upon certification by the Architect that sufficient cause exists to justify such action, the Owner may, without prejudice to any other rights or remedies of the Owner and after giving the Contractor and the Contractor's surety, if any, seven days' notice, terminate employment of the Contractor and may, subject to any prior rights of the surety:

- .1 Exclude the Contractor from the site and take possession of all materials, equipment, tools, and construction equipment and machinery thereon owned by the Contractor;
- .2 Accept assignment of subcontracts pursuant to Section 5.4; and
- .3 Finish the Work by whatever reasonable method the Owner may deem expedient. Upon written request of the Contractor, the Owner shall furnish to the Contractor a detailed accounting of the costs incurred by the Owner in finishing the Work.

§ 14.2.3 When the Owner terminates the Contract for one of the reasons stated in Section 14.2.1, the Contractor shall not be entitled to receive further payment until the Work is finished.

§ 14.2.4 If the unpaid balance of the Contract Sum exceeds costs of finishing the Work, including compensation for the Architect's services and expenses made necessary thereby, and other damages incurred by the Owner and not expressly waived, such excess shall be paid to the Contractor. If such costs and damages exceed the unpaid balance, the Contractor shall pay the difference to the Owner. The amount to be paid to the Contractor or Owner, as the case may be, shall be certified by the Initial Decision Maker, upon application, and this obligation for payment shall survive termination of the Contract.

§ 14.3 Suspension by the Owner for Convenience

§ 14.3.1 The Owner may, without cause, order the Contractor in writing to suspend, delay or interrupt the Work, in whole or in part for such period of time as the Owner may determine.

§ 14.3.2 The Contract Sum and Contract Time shall be adjusted for increases in the cost and time caused by suspension, delay, or interruption under Section 14.3.1. Adjustment of the Contract Sum shall include profit. No adjustment shall be made to the extent

- .1 that performance is, was, or would have been, so suspended, delayed, or interrupted, by another cause for which the Contractor is responsible; or
- .2 that an equitable adjustment is made or denied under another provision of the Contract.

§ 14.4 Termination by the Owner for Convenience

§ 14.4.1 The Owner may, at any time, terminate the Contract for the Owner's convenience and without cause.

§ 14.4.2 Upon receipt of notice from the Owner of such termination for the Owner's convenience, the Contractor shall

- .1 cease operations as directed by the Owner in the notice;

- .2 take actions necessary, or that the Owner may direct, for the protection and preservation of the Work; and
- .3 except for Work directed to be performed prior to the effective date of termination stated in the notice, terminate all existing subcontracts and purchase orders and enter into no further subcontracts and purchase orders.

§ 14.4.3 In case of such termination for the Owner's convenience, the Owner shall pay the Contractor for Work properly executed; costs incurred by reason of the termination, including costs attributable to termination of Subcontracts; and the termination fee, if any, set forth in the Agreement.

ARTICLE 15 CLAIMS AND DISPUTES

§ 15.1 Claims

§ 15.1.1 Definition

A Claim is a demand or assertion by one of the parties seeking, as a matter of right, payment of money, a change in the Contract Time, or other relief with respect to the terms of the Contract. The term "Claim" also includes other disputes and matters in question between the Owner and Contractor arising out of or relating to the Contract. The responsibility to substantiate Claims shall rest with the party making the Claim. This Section 15.1.1 does not require the Owner to file a Claim in order to impose liquidated damages in accordance with the Contract Documents.

§ 15.1.2 Time Limits on Claims

The Owner and Contractor shall commence all Claims and causes of action against the other and arising out of or related to the Contract, whether in contract, tort, breach of warranty or otherwise, in accordance with the requirements of the binding dispute resolution method selected in the Agreement and within the period specified by applicable law, but in any case not more than 10 years after the date of Substantial Completion of the Work. The Owner and Contractor waive all Claims and causes of action not commenced in accordance with this Section 15.1.2.

§ 15.1.3 Notice of Claims

§ 15.1.3.1 Claims by either the Owner or Contractor, where the condition giving rise to the Claim is first discovered prior to expiration of the period for correction of the Work set forth in Section 12.2.2, shall be initiated by notice to the other party and to the Initial Decision Maker with a copy sent to the Architect, if the Architect is not serving as the Initial Decision Maker. Claims by either party under this Section 15.1.3.1 shall be initiated within 21 days after occurrence of the event giving rise to such Claim or within 21 days after the claimant first recognizes the condition giving rise to the Claim, whichever is later.

§ 15.1.3.2 Claims by either the Owner or Contractor, where the condition giving rise to the Claim is first discovered after expiration of the period for correction of the Work set forth in Section 12.2.2, shall be initiated by notice to the other party. In such event, no decision by the Initial Decision Maker is required.

§ 15.1.4 Continuing Contract Performance

§ 15.1.4.1 Pending final resolution of a Claim, except as otherwise agreed in writing or as provided in Section 9.7 and Article 14, the Contractor shall proceed diligently with performance of the Contract and the Owner shall continue to make payments in accordance with the Contract Documents.

§ 15.1.4.2 The Contract Sum and Contract Time shall be adjusted in accordance with the Initial Decision Maker's decision, subject to the right of either party to proceed in accordance with this Article 15. The Architect will issue Certificates for Payment in accordance with the decision of the Initial Decision Maker.

§ 15.1.5 Claims for Additional Cost

If the Contractor wishes to make a Claim for an increase in the Contract Sum, notice as provided in Section 15.1.3 shall be given before proceeding to execute the portion of the Work that is the subject of the Claim. Prior notice is not required for Claims relating to an emergency endangering life or property arising under Section 10.4.

§ 15.1.6 Claims for Additional Time

§ 15.1.6.1 If the Contractor wishes to make a Claim for an increase in the Contract Time, notice as provided in Section 15.1.3 shall be given. The Contractor's Claim shall include an estimate of cost and of probable effect of delay on progress of the Work. In the case of a continuing delay, only one Claim is necessary.

§ 15.1.6.2 If adverse weather conditions are the basis for a Claim for additional time, such Claim shall be documented by data substantiating that weather conditions were abnormal for the period of time, could not have been reasonably anticipated, and had an adverse effect on the scheduled construction.

§ 15.1.7 Waiver of Claims for Consequential Damages

The Contractor and Owner waive Claims against each other for consequential damages arising out of or relating to this Contract. This mutual waiver includes

- .1 damages incurred by the Owner for rental expenses, for losses of use, income, profit, financing, business and reputation, and for loss of management or employee productivity or of the services of such persons; and
- .2 damages incurred by the Contractor for principal office expenses including the compensation of personnel stationed there, for losses of financing, business and reputation, and for loss of profit, except anticipated profit arising directly from the Work.

This mutual waiver is applicable, without limitation, to all consequential damages due to either party's termination in accordance with Article 14. Nothing contained in this Section 15.1.7 shall be deemed to preclude assessment of liquidated damages, when applicable, in accordance with the requirements of the Contract Documents.

§ 15.2 Initial Decision

§ 15.2.1 Claims, excluding those where the condition giving rise to the Claim is first discovered after expiration of the period for correction of the Work set forth in Section 12.2.2 or arising under Sections 10.3, 10.4, and 11.5, shall be referred to the Initial Decision Maker for initial decision. The Architect will serve as the Initial Decision Maker, unless otherwise indicated in the Agreement. Except for those Claims excluded by this Section 15.2.1, an initial decision shall be required as a condition precedent to mediation of any Claim. If an initial decision has not been rendered within 30 days after the Claim has been referred to the Initial Decision Maker, the party asserting the Claim may demand mediation and binding dispute resolution without a decision having been rendered. Unless the Initial Decision Maker and all affected parties agree, the Initial Decision Maker will not decide disputes between the Contractor and persons or entities other than the Owner.

§ 15.2.2 The Initial Decision Maker will review Claims and within ten days of the receipt of a Claim take one or more of the following actions: (1) request additional supporting data from the claimant or a response with supporting data from the other party, (2) reject the Claim in whole or in part, (3) approve the Claim, (4) suggest a compromise, or (5) advise the parties that the Initial Decision Maker is unable to resolve the Claim if the Initial Decision Maker lacks sufficient information to evaluate the merits of the Claim or if the Initial Decision Maker concludes that, in the Initial Decision Maker's sole discretion, it would be inappropriate for the Initial Decision Maker to resolve the Claim.

§ 15.2.3 In evaluating Claims, the Initial Decision Maker may, but shall not be obligated to, consult with or seek information from either party or from persons with special knowledge or expertise who may assist the Initial Decision Maker in rendering a decision. The Initial Decision Maker may request the Owner to authorize retention of such persons at the Owner's expense.

§ 15.2.4 If the Initial Decision Maker requests a party to provide a response to a Claim or to furnish additional supporting data, such party shall respond, within ten days after receipt of the request, and shall either (1) provide a response on the requested supporting data, (2) advise the Initial Decision Maker when the response or supporting data will be furnished, or (3) advise the Initial Decision Maker that no supporting data will be furnished. Upon receipt of the response or supporting data, if any, the Initial Decision Maker will either reject or approve the Claim in whole or in part.

§ 15.2.5 The Initial Decision Maker will render an initial decision approving or rejecting the Claim, or indicating that the Initial Decision Maker is unable to resolve the Claim. This initial decision shall (1) be in writing; (2) state the reasons therefor; and (3) notify the parties and the Architect, if the Architect is not serving as the Initial Decision Maker, of any change in the Contract Sum or Contract Time or both. The initial decision shall be final and binding on the parties but subject to mediation and, if the parties fail to resolve their dispute through mediation, to binding dispute resolution.

§ 15.2.6 Either party may file for mediation of an initial decision at any time, subject to the terms of Section 15.2.6.1.

§ 15.2.6.1 Either party may, within 30 days from the date of receipt of an initial decision, demand in writing that the other party file for mediation. If such a demand is made and the party receiving the demand fails to file for mediation within 30 days after receipt thereof, then both parties waive their rights to mediate or pursue binding dispute resolution proceedings with respect to the initial decision.

§ 15.2.7 In the event of a Claim against the Contractor, the Owner may, but is not obligated to, notify the surety, if any, of the nature and amount of the Claim. If the Claim relates to a possibility of a Contractor's default, the Owner may, but is not obligated to, notify the surety and request the surety's assistance in resolving the controversy.

§ 15.2.8 If a Claim relates to or is the subject of a mechanic's lien, the party asserting such Claim may proceed in accordance with applicable law to comply with the lien notice or filing deadlines.

§ 15.3 Mediation

§ 15.3.1 Claims, disputes, or other matters in controversy arising out of or related to the Contract, except those waived as provided for in Sections 9.10.4, 9.10.5, and 15.1.7, shall be subject to mediation as a condition precedent to binding dispute resolution.

§ 15.3.2 The parties shall endeavor to resolve their Claims by mediation which, unless the parties mutually agree otherwise, shall be administered by the American Arbitration Association in accordance with its Construction Industry Mediation Procedures in effect on the date of the Agreement. A request for mediation shall be made in writing, delivered to the other party to the Contract, and filed with the person or entity administering the mediation. The request may be made concurrently with the filing of binding dispute resolution proceedings but, in such event, mediation shall proceed in advance of binding dispute resolution proceedings, which shall be stayed pending mediation for a period of 60 days from the date of filing, unless stayed for a longer period by agreement of the parties or court order. If an arbitration is stayed pursuant to this Section 15.3.2, the parties may nonetheless proceed to the selection of the arbitrator(s) and agree upon a schedule for later proceedings.

§ 15.3.3 Either party may, within 30 days from the date that mediation has been concluded without resolution of the dispute or 60 days after mediation has been demanded without resolution of the dispute, demand in writing that the other party file for binding dispute resolution. If such a demand is made and the party receiving the demand fails to file for binding dispute resolution within 60 days after receipt thereof, then both parties waive their rights to binding dispute resolution proceedings with respect to the initial decision.

§ 15.3.4 The parties shall share the mediator's fee and any filing fees equally. The mediation shall be held in the place where the Project is located, unless another location is mutually agreed upon. Agreements reached in mediation shall be enforceable as settlement agreements in any court having jurisdiction thereof.

§ 15.4 Arbitration

§ 15.4.1 If the parties have selected arbitration as the method for binding dispute resolution in the Agreement, any Claim subject to, but not resolved by, mediation shall be subject to arbitration which, unless the parties mutually agree otherwise, shall be administered by the American Arbitration Association in accordance with its Construction Industry Arbitration Rules in effect on the date of the Agreement. The Arbitration shall be conducted in the place where the Project is located, unless another location is mutually agreed upon. A demand for arbitration shall be made in writing, delivered to the other party to the Contract, and filed with the person or entity administering the arbitration. The party filing a notice of demand for arbitration must assert in the demand all Claims then known to that party on which arbitration is permitted to be demanded.

§ 15.4.1.1 A demand for arbitration shall be made no earlier than concurrently with the filing of a request for mediation, but in no event shall it be made after the date when the institution of legal or equitable proceedings based on the Claim would be barred by the applicable statute of limitations. For statute of limitations purposes, receipt of a written demand for arbitration by the person or entity administering the arbitration shall constitute the institution of legal or equitable proceedings based on the Claim.

§ 15.4.2 The award rendered by the arbitrator or arbitrators shall be final, and judgment may be entered upon it in accordance with applicable law in any court having jurisdiction thereof.

§ 15.4.3 The foregoing agreement to arbitrate and other agreements to arbitrate with an additional person or entity duly consented to by parties to the Agreement, shall be specifically enforceable under applicable law in any court having jurisdiction thereof.

§ 15.4.4 Consolidation or Joinder

§ 15.4.4.1 Subject to the rules of the American Arbitration Association or other applicable arbitration rules, either party may consolidate an arbitration conducted under this Agreement with any other arbitration to which it is a party provided that (1) the arbitration agreement governing the other arbitration permits consolidation, (2) the arbitrations to be consolidated substantially involve common questions of law or fact, and (3) the arbitrations employ materially similar procedural rules and methods for selecting arbitrator(s).

§ 15.4.4.2 Subject to the rules of the American Arbitration Association or other applicable arbitration rules, either party may include by joinder persons or entities substantially involved in a common question of law or fact whose presence is required if complete relief is to be accorded in arbitration, provided that the party sought to be joined consents in writing to such joinder. Consent to arbitration involving an additional person or entity shall not constitute consent to arbitration of any claim, dispute or other matter in question not described in the written consent.

§ 15.4.4.3 The Owner and Contractor grant to any person or entity made a party to an arbitration conducted under this Section 15.4, whether by joinder or consolidation, the same rights of joinder and consolidation as those of the Owner and Contractor under this Agreement.

SUPPLEMENTARY CONDITIONS OF THE CONTRACT

1. DEFINITIONS - Supplement Paragraph 1.1 as follows:
 - a. When words such as approved, proper, satisfactory, equal, and as directed are used, they imply such reference to the Architect's specific approval and directions.
 - b. Provide means to furnish and install.
 - c. The provisions of the Agreement take precedence over all other Contract Documents.
2. WARRANTY - Supplement Paragraph 3.5.1 as follows:
 - a. Contractor warrants to Owner and Architect that on receipt of notice from either of them, within the period of one (1) year following date of Substantial Completion, that defects in materials and/or workmanship have appeared in the Work, Contractor will promptly correct such defects to the state of condition originally required by the Contract Documents at Contractor's expense.
3. SHOP DRAWINGS - Supplement Paragraph 3.12 as follows:
 - a. The Contractor shall submit **one (1) electronic copy** of all Shop or Setting Drawings and Schedules required for the work of the various trades, after same have been checked and compared with the Contract Document Requirements, and after checking with field conditions at the job and so certified on the Drawings by the Contractor. Above Drawings will not be checked by Architect unless same bear certification.
 - b. Architect's approval is subject to notations on Drawings, Compliance with Drawings and Specifications, and conditions and measurements at project. Measurements and quantity not checked or approved.
4. SAMPLES - Supplement Subparagraph 3.12.3 as follows:
 - a. All samples as called for in the various Sections of this Specification and any other samples, as directed, shall be furnished by the Contractor for approval.
 - b. All samples of materials that require approval as to color, texture, finish and type shall be furnished at the same time, so that an intelligent selection of colors and textures may be made by the Architect.
5. COLOR SELECTIONS
 - a. The Contractor shall provide for and coordinate into the project construction schedule, a 6-week time frame for the Architect/Designer to make final color selections from Contractor's submittals, obtain approval from the Owner and to submit a color schedule, indicating what colors go where, to the Contractor. Time frame begins when Architect has received 100% of submittals listed below.
 - b. Submittals, i.e., actual samples, manufacturers' literature, full color line options, etc., shall include as a minimum, but not limited to:
 - Carpet Types
 - Sheet Vinyl Flooring
 - Vinyl Composition Tile Flooring
 - Vinyl Base
 - Ceramic Wall Tile
 - Ceiling Types
 - Paint
 - Corner Guards
 - Plastic Laminate (Manufacturer)
 - Wood Stain for Doors and Woodwork
 - Aluminum Storefront System
 - Stone Veneer/Brick/Masonry
 - Metal Panels and Siding Products

6. CLEAN UP - Supplement Paragraph 3.15 as follows:
- a. Each Contractor shall, at all times, remove any and all of his rubbish from the buildings and grounds and keep the building site clean.
 - b. In addition to the general broom cleaning, the General Contractor shall do the following special cleaning for all trades at the completion of the work:
 - 1) Glass. Remove putty, stains and paint from all glass and wash and polish same. Care shall be taken not to scratch the glass.
 - 2) Painted, Decorated, and Stained Work. Remove all marks, stains, fingerprints and other soil or dirt from all painted, decorated and stained work.
 - 3) Temporary Protection. Remove all temporary protections; clean and polish all floors at completion.
 - 4) Woodwork. Clean and polish all woodwork upon completion.
 - 5) Hardware. Clean and polish all hardware for all trades. This shall include removal of all stains, dust, dirt, paint, etc., upon completion.
 - 6) Tile Work. Remove all spots, soil and paint from all tile work, wash same upon completion.
 - 7) Fixtures and Equipment. Clean all fixtures and equipment, removing all stains, paint, dirt and dust.
 - c. All combustible rubbish, and all debris and other rubbish shall be removed entirely from the premises.

7. MUTUAL RESPONSIBILITY OF CONTRACTORS - Supplement Paragraph 6.2 as follows:

- a. General Contractor shall assume general coordination and direction of the project. General Contractor shall cooperate with Mechanical and Electrical Contractors and other subcontractors and/or suppliers on the Work and install their work in sequence to facilitate and not delay the completion of the project. The Architect is not the coordinator or expeditor of the work of the contractors and/or subcontractors referred to hereinbefore.

8. CHANGES IN THE WORK

Refer to Paragraph 7.2 and insert the following:

- a. Whenever a Change Order involves net cost decrease, the CREDIT to the Owner shall be such net cost decrease. Whenever a Change Order involves a summary net increase, the Contract shall be increased by the amount of such net cost increase plus 10% of such net cost for overhead and profit. The General Contractor will furnish supervision and coordination for 10% of the cost of additional Mechanical and Electrical work ordered by the Owner.
- b. The Contractor shall furnish the Owner an itemized accounting with supporting data used in computing the value of any change that might be ordered.
- c. Change Orders must state a number of added days or days to be deleted from completion time. If no change in days is required by the change order, write NONE. Failure to comply with above voids any later request for extra time.

9. APPLICATION FOR PROGRESS PAYMENTS AND CERTIFICATION FOR PAYMENT

- a. Amend Subparagraph 9.3.1 and insert the following: On or before the 1st day of each month, the Contractor shall submit to the Architect an itemized Application for Payment supported by such data substantiating the Contractor's right to payment as the Owner or Architect may require.
- b. Amend Subparagraph 9.4.1 and insert: If the Contractor has made application for payment as above, the Architect will, with reasonable promptness and within ten (10) days after receipt of the application, issue an application for payment to the Owner, with a copy to the Contractor in the amount of 90% of the value of the Contract the Architect determines has been completed to the date of application, thus a 10% retainage, less any amount paid to the Contractor, or state in writing his reason for withholding an application as provided in Subparagraph 9.5.1.

- c. Date of payment of the Application for Payment by the Owner is hereby defined as the earliest possible date that the Owner can prepare vouchers after receipt of Application for Payment from the Architect and approval of same by any governing body of the Owner and issuance of vouchers to cover Application for Payment.

10. CONTRACTOR'S LIABILITY INSURANCE

- a. Workers' Compensation and Employers Liability Insurance - Refer to Subparagraph 11.1.1.
- b. Bodily Injury and Property Damage - Refer to Subparagraph 11.1.2. Limits shall be as follows:
 - (1) Limits of liability coverage shall be \$2,000,000.00 Combined Single Limit for Bodily Injury and Property Damage.
- c. Owner's Protective Liability Insurance - Refer to Paragraph 11.2 - Owner's Option.

11. PERFORMANCE AND PAYMENT BONDS - Supplement Subparagraph 11.4.1 as follows:

- a. Bond shall be equivalent to AIA Form A311, two part Performance Bond and Labor and Materials Bond with amount shown on each part equal to 100% of the total amount payable by the terms of the Contract. Surety shall be company licensed to do business at the place of building and shall be acceptable to the Owner.

END OF SECTION

Grand View Property

Geotechnical Engineering Report

Laramie, Wyoming

June 10, 2024 | Terracon Project No. 24245022

Prepared for:

Jones Gillam Renz Architects, Inc.
730 North 9th Street
Salina, Kansas 67401

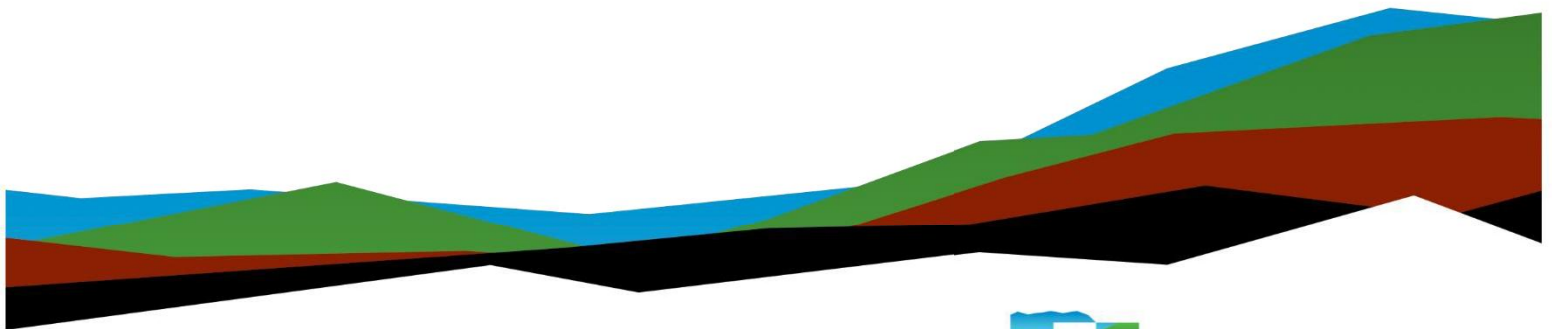

Nationwide
[Terracon.com](https://www.terracon.com)

- Facilities
- Environmental
- Geotechnical
- Materials



1505 Old Happy Jack Road
Cheyenne, WY 82001
P (307) 632-9224
Terracon.com

June 10, 2024

Jones Gillam Renz Architects, Inc.
730 North 9th Street
Salina, Kansas 67401

Attn: Maggie Gillam
P: (785) 827-0386
E: mgillam@jgrarchitects.com

Re: Geotechnical Engineering Report
Grand View Property
3800 Bill Nye Avenue
Laramie, Wyoming
Terracon Project No. 24245022

Dear Ms. Gillam:

We have completed the scope of Geotechnical Engineering services for the project referenced above in general accordance with Terracon Proposal No. P24245022 dated February 13, 2024. This report presents the findings of the subsurface exploration and provides geotechnical recommendations concerning earthwork, the design and construction of foundations, floor slabs, and pavements for the proposed project.

We appreciate the opportunity to be of service to you on this project. If you have any questions concerning this report or if we may be of further service, please contact us.

Sincerely,

Terracon

Emily Sinnott
Staff Engineer

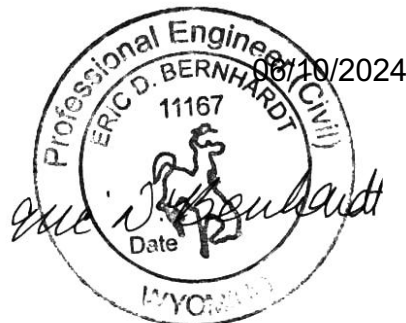

Eric D. Bernhardt, P.E.
Principal

Table of Contents

Report Summary	i
Introduction.....	1
Project Description.....	1
Site Conditions	3
Geotechnical Characterization	3
Seismic Site Class.....	4
Corrosivity.....	4
Water Soluble Sulfate.....	5
Geotechnical Overview	6
Existing Fill.....	6
Earthwork	7
Demolition.....	7
Existing Fill.....	8
Site Preparation.....	8
Subgrade Preparation Below Structural Areas.....	9
Pavement Subgrade Preparation.....	10
Exterior Flatwork and Sidewalk Design and Construction	10
Fill Material Types.....	11
Fill Placement and Compaction Requirements	12
Utility Trench Backfill.....	13
Grading and Drainage.....	13
Earthwork Construction Considerations	14
Construction Observation and Testing	14
Shallow Foundations	15
Design Parameters – Compressive Loads	15
Foundation Construction Considerations	16
Floor Slabs	16
Floor Slab Design Parameters	16
Floor Slab Construction Considerations.....	18
Pavements	18
General Pavement Comments	18
Pavement Design Parameters	18
Pavement Section Thicknesses.....	19
Pavement Maintenance	20
Frost Considerations.....	20
General Comments	21

Figures

GeoModel

Attachments

Exploration and Testing Procedures

Photography Log

Site Location and Exploration Plans

Exploration and Laboratory Results

Supporting Information

Note: This report was originally delivered in a web-based format. **Blue Bold** text in the report indicates a referenced section heading. The PDF version of this page includes hyperlinks which direct the reader to that section and clicking on the  logo will bring you back to this page. For more interactive features, please view your project online at client.terracon.com.

Refer to each individual Attachment for a listing of contents.

Report Summary

Topic ¹	Overview Statement ²
<p>Project Description</p>	<p>The project includes the construction of two, three-story buildings within the designated Overland area. The Overland development site is approximately 1.95 acres, with the proposed buildings occupying approximately 1.13 acres situated on the northern and southern perimeters of the Overland development. The residual parcel of the development has been allocated for the creation of 82 parking stalls, along with a clubhouse, a designated area for trash enclosure and a driveway to facilitate access.</p>
<p>Geotechnical Characterization</p>	<p>Subsurface soil conditions are generally characterized by medium dense to dense sand with vary amounts of silt, clay, and gravel. Surficial material generally consists of about 3 to 10 inches of vegetative soil and root penetration. Groundwater was not encountered to a maximum boring depth of approximately 25.5 feet below existing ground surface.</p>
<p>Earthwork</p>	<p>Based on the subsurface conditions encountered and proposed building construction, our earthwork recommendations consist of the following:</p> <ul style="list-style-type: none"> ■ Remove existing fill below the proposed foundations and floor slabs and backfill with properly compacted structural fill, ■ Remove at least 12-inches of existing fill below pavements and replacement with properly compacted structural fill, and ■ Existing fill soils can be used for structural or general fill.
<p>Shallow Foundations</p>	<p>Shallow spread footings can be utilized for the proposed project provided the existing fill soils below the foundation are removed and reworked with proper moisture condition and compaction, prepared in accordance with the Earthwork section.</p> <ul style="list-style-type: none"> ■ Maximum net allowable bearing pressure of 2,500 psf for strip footings up to 4 feet wide ■ Maximum net allowable bearing pressure of 4,000 psf for square footings up to 7 feet ■ Minimum embedment depth of 36 inches ■ Total settlement of about 1 inch

Topic ¹	Overview Statement ²
Pavements	<p>Based on anticipated traffic data described in this report and with subgrade prepared as noted in the Earthwork section of this report, the following presents recommended minimum pavement sections:</p> <ul style="list-style-type: none">■ 4 inches AC over 6 inches ABC in parking/ driveway areas

1. If the reader is reviewing this report as a pdf, the topics above can be used to access the appropriate section of the report by simply clicking on the topic itself.
2. This summary is for convenience only. It should be used in conjunction with the entire report for design purposes.

Introduction

This report presents the results of our subsurface exploration and Geotechnical Engineering services performed for the proposed buildings to be located at 3800 Bill Nye Avenue in Laramie, Wyoming. The purpose of these services was to provide information and geotechnical engineering recommendations relative to:

- Subsurface soil conditions
- Seismic site classification per IBC
- Site preparation and earthwork
- Demolition considerations
- Foundation design and construction
- Floor slab design and construction
- Pavement design and construction
- Frost considerations

The geotechnical engineering Scope of Services for this project included the advancement of test borings, laboratory testing, engineering analysis, and preparation of this report.

Drawings showing the site and boring locations are shown on the [Site Location](#) and [Exploration Plan](#), respectively. The results of the laboratory testing performed on soil samples obtained from the site during our field exploration are included on the boring logs and as separate graphs in the [Exploration Results](#) section.

Project Description

Our initial understanding of the project was provided in our proposal and was discussed during project planning. A period of collaboration has transpired since the project was initiated, and our final understanding of the project conditions is as follows:

Item	Description
<p>Information Provided</p>	<p>Information for this project was provided by Maggie Gillam with JGR via e-mail beginning on February 7, 2024.</p> <p>The following documents were provided:</p> <ul style="list-style-type: none"> ■ Grand View Heights (GVH) Property, dated 8/19/2022 ■ GVH 9th design, dated 1/09/2024 ■ Preliminary Drawings of the New Apartment Complex Buildings for the GVH property, dated 2/1/2024 ■ Aerial Map of the project site, dated 2/7/2024 ■ Professionally Surveyed Topography Plot, dated 2/26/2024
<p>Project Description</p>	<p>The project includes the construction of two, three-story buildings within the designated Overland area. The Overland development site is approximately 1.95 acres, with the proposed buildings occupying approximately 1.13 acres situated on the northern and southern perimeters of the Overland development. The residual parcel of the development has been allocated for the creation of 82 parking stalls, along with a clubhouse, a designated area for trash enclosure and a driveway to facilitate access.</p>
<p>Proposed Structures</p>	<p>The supplied site plan shows the proposed buildings consisting of two, three-story buildings, a clubhouse, a BBQ/picnic area, and a tot lot (playground).</p>
<p>Building Construction</p>	<p>We anticipate the buildings will be wood and/or steel-framed construction supported on shallow, reinforced concrete, spread footing foundations with a slab-on-grade floor system.</p>
<p>Finished Floor Elevation (FFE)</p>	<p>We understand the FFE of the north building will be approximately 7,346 feet and approximately 7,336 feet for the south building.</p>
<p>Maximum Loads</p>	<p>Anticipated structural loads were not provided at the time of this report. However, based on our experience with similar projects, we assume the following maximum loading conditions:</p> <ul style="list-style-type: none"> ■ Columns: <100 kips ■ Walls: <3 kips per linear foot (klf) ■ Slabs: <150 pounds per square foot (psf)
<p>Grading/Slopes</p>	<p>We understand final grades will closely correspond to the elevations of existing site features. We assume minimal (less than 6 feet) cuts/fills will be necessary to achieve desired final grade.</p>

Item	Description
Below-Grade Structures	None anticipated for site development.
Pavements	Traffic types and volumes were not provided at the time of this report. We understand rigid (concrete), and flexible (asphalt concrete) sections will be considered for construction with a pavement design period of 20 years.

Terracon should be notified if any of the above information is inconsistent with the planned construction, especially the grading limits, as modifications to our recommendations may be necessary.

Site Conditions

The following description of site conditions is derived from our site visit in association with the field exploration and our review of publicly available geologic and topographic maps.

Item	Description
Location	The project is located at 3800 Bill Nye Avenue in Laramie, Wyoming. Approximate coordinates at the north and south ends of the project area are approximately 41.2961°N, 105.5467°W and 41.2952°N, 105.5467°W, respectively. See Site Location
Existing Improvements	Based on the review of historical aerial imagery (Google Earth Pro) and our site visit, the project site exhibits signs of prior development and has undergone a degree of site grading. There are stockpiles of cobbles, soils, and debris on the site.
Current Ground Cover	Current ground cover consists of mostly native grasses and weeds with some barren ground.
Existing Topography	The project site’s elevation slopes down approximately 10 feet towards the southeast corner and the west side of the site.

Geotechnical Characterization

We have developed a general characterization of the subsurface conditions based upon our review of the subsurface exploration, laboratory data, geologic setting and our understanding of the project. This characterization, termed GeoModel, forms the basis of our geotechnical calculations and evaluation of the site. Conditions observed at each

exploration point are indicated on the individual logs. The individual logs can be found in the **Exploration Results** and the GeoModel can be found in the **Figures** attachment of this report.

As part of our analyses, we identified the following model layers within the subsurface profile. For a more detailed view of the model layer depths at each boring location, refer to the GeoModel.

Model Layer	Layer Name	General Description
1	Surficial Material	About 3 to 10 inches of vegetative soil and root penetration. About 3 inches of apparent aggregate base course in Boring Nos. P-03 and P-04.
2	Existing Fill	Fine to coarse grain sands with varying amounts of silt, clay, and fine to coarse grained gravel. Reddish brown to red.
3	Native Soil	Medium dense to dense sand with varying amounts of silt, clay, and gravel. Fine to coarse grained sand and gravel. Very stiff to hard sandy silt, fine to medium grained. Generally reddish brown to red.

Seismic Site Class

Seismic design requirements for buildings and other structures are based on Seismic Design Category. Site Classification is required to determine the Seismic Design Category for a structure. The Site Classification is based on the upper 100 feet of the site profile defined by a weighted average value of either shear wave velocity, standard penetration resistance, or undrained shear strength in accordance with Section 20.4 of ASCE 7 and the International Building Code (IBC). Based on the soil properties observed at the site and as described on the exploration logs and results, we recommend a **Seismic Site Classification of D** be considered for the project. Subsurface explorations at this site were extended to a maximum depth of about 25.5 feet. The site properties below the boring depth to 100 feet were estimated based on our experience and knowledge of geologic conditions of the general area. Additional deeper borings or geophysical testing may be performed to confirm the conditions below the current boring depth.

Corrosivity

The table below lists the results of laboratory pH, soluble sulfate, sulfides, soluble chloride, RedOx, total salts, and electrical resistivity testing. The values may be used to

estimate potential corrosive characteristics of the on-site soils with respect to contact with the various underground materials which will be used for project construction.

Corrosivity Test Results Summary

Boring No.	Sample Depth (feet)	Soil Description	pH	Soluble Sulfate (mg/kg)	Sulfides (mg/kg)	Soluble Chloride (mg/kg)	RedOx (mV)	Total Salts (mg/kg)	Electrical Resistivity ¹ (Ω-cm)
B-5	1 to 5	Silty Sand	6.0	23	0	20	+239	1,669	5,225

1. Test performed on a saturated soil sample.

These values serve as crucial indicators for assessing the potential corrosive characteristics of on-site soils concerning their interaction with various underground materials slated for project construction. For detailed results of corrosivity testing conducted on soil samples during exploration, please refer to the Chemical Laboratory Test Results section within the [Exploration and Laboratory Results](#).

It is imperative to note that the corrosion information provided is specific to the tested samples. If the actual soil composition in contact with the structures at the site differs from those tested, additional corrosion testing should be considered. It is important to emphasize that Terracon's expertise does not extend to corrosion engineering. Our scope of work was limited to conducting corrosion laboratory tests on selected samples and presenting the results alongside a brief comparison to selected criteria. Should concerns regarding the corrosion of underground utilities and structures persist, it is strongly recommended to engage the services of a qualified corrosion engineer for further evaluation and guidance tailored to the specific needs of this project.

Water Soluble Sulfate

The sulfate concentration measured in the sample is 23 mg/kg which equates to approximately 0.0023 percent. Sulfate concentrations of less than 0.1 percent indicate Class 0 exposure to sulfate attack for concrete in contact with the subsoils, according to the American Concrete Institute (ACI) *Guide to Durable Concrete*. For this level of sulfate concentrations, ACI indicates any type of cement can be used for concrete in contact with the subsoils. Therefore, Type I or IL portland cement should be suitable for concrete on and below grade. However, if there is no or minimal cost differential, use of Type II portland cement (or equivalent) should be considered for additional sulfate resistance of construction concrete. Foundation concrete should be designed in accordance with the provisions of the *ACI Design Manual*, Section 318.

Geotechnical Overview

The geotechnical conditions at this site appear suitable for the proposed construction based upon soils encountered in the test borings, provided the recommendations provided in this report are implemented in the design and construction phases of this project.

The subsurface materials generally consisted of sand with varying amounts of silt, clay, and gravel extending to the maximum depth of the borings. Groundwater was not encountered within the maximum depths of exploration during or at the completion of drilling.

Based on the conditions encountered and estimated load-settlement relationships, the proposed structures can be supported on conventional continuous or spread footings.

Due to the undocumented fill across the site, the foundations should be supported on structural fill. Structural fill for the proposed foundations should incorporate the limits of the foundations plus a lateral distance beyond the outside edge of footings, where space is available. On-site soils are considered suitable to be used as engineered fill materials.

If possible, grading should be performed during the warmer and drier times of the year. If grading is performed during the winter months, an increased risk for possible undercutting and replacement of unstable subgrade will persist. Additional site preparation recommendations, including subgrade improvement and fill placement, are provided in the [Earthwork](#) section.

Our opinion of pavement section thickness design has been developed based on our understanding of the intended use, assumed traffic, and subgrade preparation recommended herein using methodology contained in NAPA IS-109 "Design of Hot Mix Asphalt Pavements" and adjusted with consideration to local practice. The [Pavements](#) section includes minimum pavement component thickness.

Existing Fill

Existing fill was encountered to depths of about 1 to 6 feet below the existing ground surface at each boring location. Fill may be present at other locations on the site and extend to depths greater than 6 feet. We are not aware of documentation of the placement of the existing fill under the testing and observation of a geotechnical engineer. Therefore, for the purpose of this report, the existing fill soils are considered undocumented and should be considered uncontrolled. Uncontrolled fills can present a risk of post-construction movement to foundations, floor slabs, and other site improvements supported on or above these materials. Consequently, we recommend existing fills be removed and replaced with engineered fill within the area of the planned improvements prior to placing any new fill or construction.

Support of floor slabs and pavements on or above existing fill materials is discussed in this report. However, even with the recommended construction procedures, an inherent risk remains for the owner that compressible fill or unsuitable material, within or buried by the fill, will not be discovered. This risk of unforeseen conditions cannot be eliminated without completely removing the existing fill but can be reduced by following the recommendations contained in this report.

The lowest risk alternative is complete removal of the fill below pavements and replacement with newly placed, properly compacted engineered fill. However, complete removal of fill materials below proposed pavements will likely be very cost prohibitive. If the Owner is willing to accept the risk of potential movements and poor performance of pavements, partial removal and replacement with newly placed, properly compacted engineered fill could be considered. At a minimum, we recommend over-excavating at least 12-inches of the existing fill below pavements and replacement with newly placed, properly compacted engineered fill.

Earthwork

Earthwork is anticipated to include demolition, clearing and grubbing, excavations, and engineered fill placement. The following sections provide recommendations for use in the preparation of specifications for the work. Recommendations include critical quality criteria, as necessary, to render the site in the state considered in our geotechnical engineering evaluation for foundations, floor slabs, and pavements.

Demolition

Demolition of the existing site development should include complete removal of all existing stockpiles of cobbles, soils, and debris on the site. All materials derived from the demolition should be removed from the site.

Our experience suggests a portion of the demolition site features sometimes happens weeks to several months prior to site grading and new construction. Our recommendations for subgrade preparation, fill placement, and other activities associated with earthwork on the project site should be performed during these initial demolition activities. We recommend fill be placed and tested for moisture content and percent compaction during backfill of the excavations made during initial demolition activities. If the fill materials are not properly placed and confirmed with compaction testing, there is an increased risk of movement and poor performance for foundations, floor slabs, pavements or other site features constructed on the fill placed as part of restoring the site after initial demolition.

Existing Fill

As noted in **Geotechnical Characterization**, existing fill was encountered to a depth of about 1 to 6 feet below the existing ground surface at each boring location. These materials may be present at other locations on the site and extend to greater depths. We have no records to indicate the degree of control, and consequently, the fill is considered unreliable for support of foundation loads. Support of floor slabs and pavements on or above existing fill soils is discussed in this report. However, even with the recommended construction procedures, inherent risk exists for the owner that compressible fill or unsuitable material, within or buried by the fill will, not be discovered. This risk of unforeseen conditions cannot be eliminated without completely removing the existing fill but can be reduced by following the recommendations contained in this report. The existing fill soils should be suitable for reuse in new fills and backfill, provided debris, organics and other unsuitable materials are removed. Terracon's services did not include delineating the horizontal or vertical extent of the existing fill material. Therefore, we suggest additional geotechnical exploration and evaluation be conducted at the site prior to construction. At a minimum, a series of excavation test pits/trenches could be excavated on the site to more accurately define the vertical and lateral extent of the fill materials and the composition of the fill.

The lowest risk alternative is complete removal of the fill below pavements and replacement with newly placed, properly compacted engineered fill. However, complete removal of fill materials below proposed pavements will likely be very cost prohibitive. If the Owner is willing to accept the risk of potential movements and poor performance of pavements, partial removal and replacement with newly placed, properly compacted engineered fill could be considered. At a minimum, we recommend over-excavating at least 12-inches of the existing fill below pavements and replacement with newly placed, properly compacted engineered fill.

Site Preparation

Prior to placing fill, existing vegetation, topsoil, and root mats should be removed. Complete stripping of the topsoil should be performed in the proposed building and parking/driveway areas.

Although no evidence of fill or underground facilities (such as septic tanks, cesspools, basements, and utilities) was observed during the exploration and site reconnaissance, such features could be encountered during construction. If unexpected fills or underground facilities are encountered, such features should be removed, and the excavation thoroughly cleaned prior to backfill placement and/or construction.

If unstable or soft ground conditions develop during earthwork or other construction activities, some method of soil improvement or stabilization will be needed prior to fill placement and/or foundation, floor slab, or pavement construction. A stable subgrade

can be defined as the condition in which the subgrade exhibits little to no yielding (less than 1 inch of deflection) under a loaded water truck or tandem-axel dump truck, After stable conditions are achieved, fill placement and/or construction can continue. There are a number of stabilizations methods that can be used to improve the subgrade and depend, in part, on the extent and severity of the unstable soils exposed during construction as well as other factors. These soil stabilization methods are further discussed in the **Soil Stabilization** section of the report. In any event, we feel the appropriate method and level of stabilization should be evaluated and can best be determined on a case-by-case basis during construction once the entire subgrade and overall conditions are exposed.

Subgrade Preparation Below Structural Areas

Subgrade preparation efforts are required to render the site suitable for supporting a shallow foundation system and to mitigate estimated foundation settlement within tolerable limits. Upon completion of demolition, stripping, and complete removal of existing fill, the subgrade soils within the footprint of the proposed structures should be scarified, moisture conditioned as necessary, and compacted per the compaction requirements in the **Fill Placement** and **Compaction Requirements** section of this report. Compacted structural fill soils should then be placed to the proposed design grade and the moisture content and compaction of subgrade soils should be maintained until foundation construction.

Where encountered, existing fill and unsuitable areas of soft/loose subgrade should be over-excavation below and beyond the lateral extents of the proposed foundation systems as generally depicted in the sketch below. The over-excavation activities should be performed under the observation of the Geotechnical Engineer or representative.

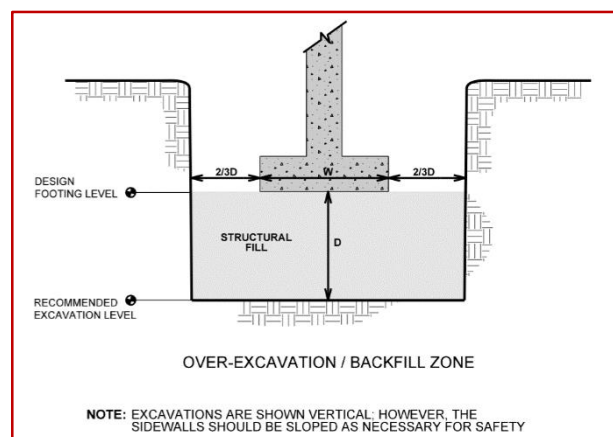

Based upon the subsurface conditions determined from the geotechnical exploration, subgrade soils exposed during construction are anticipated to be relatively workable; however, the workability of the subgrade may be affected by precipitation, repetitive

construction traffic or other factors. If unworkable conditions develop, workability may be improved by scarifying and drying.

Pavement Subgrade Preparation

A critical aspect of pavement performance is subgrade preparation. Subgrade preparation efforts are required in order to render the site suitable for support of pavement sections on this project.

As discussed in the **Geotechnical Overview** section, existing fill was encountered to depths of about 1 to 6 feet below the existing ground surface at each boring location. These materials could extend to greater depths at other locations on this site. Undocumented existing fills can present a risk of post-construction movement to pavements, and other site improvements supported on or above these materials.

If some risk of pavement settlement can be accepted, consideration could be given to supporting pavements on at least 12 inches of reworked (over-excavated, moisture conditioned, and recompacted) existing fill materials. However, if the client cannot accept the risk of pavement settlements, existing fill materials encountered below proposed pavement areas should be completely removed and replaced prior to placement of site grading fills or aggregate base course material. We recommend the compaction procedures follow the **Compaction Requirements** section of this report.

Additionally, prior to pavement operations, we recommend the prepared subgrade be proof-rolled in the presence of the Geotechnical Engineer or representative using heavy construction equipment, such as a loaded water truck or tandem-axel dump truck, to help delineate weak or disturbed areas (greater than 1 inch of deflection) at or near the ground surface. Particular attention should be paid to high traffic areas that were rutted and disturbed earlier and to areas where backfilled trenches are located. Areas delineated by the proof-roll should be over-excavated and replaced with approved fill if the affected materials cannot be moisture conditioned and compacted in place, or the subgrade should be stabilized by other suitable methods as previous described in this report.

Exterior Flatwork and Sidewalk Design and Construction

Exterior concrete flatwork, sidewalk, curb, exterior architectural features, and utilities founded on or in backfill, or the site soils will likely experience some movements due to the volume change of the material and the presence of existing fill. Therefore, to improve the performance of exterior flatwork and sidewalks and reduce the potential for movement, we recommend 12 inches of the existing fill below any exterior flatwork and sidewalk be scarified, moisture conditioned, and recompacted to provide uniform support and reduce the risk of movement. On-site soils are suitable as fill material below exterior

flatwork and sidewalks. Potential movement of the subgrade soils below exterior flatwork and sidewalks could also be reduced by:

- Minimizing moisture increases in the backfill;
- Controlling moisture-density during placement of the backfill;
- Using design which allow vertical movement between the exterior features and adjoining structural elements; and
- Placing control joints on relatively close centers.

We recommend the exterior concrete flatwork and sidewalk design be based on local municipality standards and specifications.

Fill Material Types

Engineered fill required to achieve design grade should be classified as structural fill and general fill. Structural fill is material used below, or within 7 feet of structures, pavements, or constructed slopes. General fill is material acceptable for use above foundations as excavation backfill.

On-site soils free of vegetation, organic matter, and other unsuitable materials or import materials approved by Terracon may be used as structural fill or general fill on the site.

Imported Fill Materials: Imported fill materials should meet the following material property requirements. Regardless of its source, compacted fill should consist of approved materials that are free of organic matter and debris. Frozen material should not be used, and fill should not be placed on a frozen subgrade.

Soil Type ¹	USCS Classification	Acceptable Parameters (for Structural Fill)
Granular	GW, GP, GM, GC, SW, SP, SM, SC	Maximum particle size of 3 inches
Wyoming Department of Transportation (WYDOT) Grade W or L	Varies	Liquid Limit less than 30, Plasticity Index less than 15 Less than 45% passing the No. 200 sieve

1. A sample of each material type should be submitted to the Geotechnical Engineer for evaluation prior to use on this site. Additional geotechnical consultation should be provided prior to use of uniformly graded gravel on the site.

Fill Placement and Compaction Requirements

Structural and general fill should meet the following compaction requirements.

Item	Structural Fill	General Fill
Maximum Lift Thickness	9 inches or less in loose thickness when heavy, self-propelled compaction equipment is used 4 to 6 inches in loose thickness when hand-guided equipment (i.e. jumping jack or plate compactor) is used	Same as structural fill
Minimum Compaction Requirements ^{1,2}	At least 98% of the standard Proctor maximum dry density (ASTM D698) for fill/backfill below foundations and floor slabs. At least 95% of the standard Proctor maximum dry density (ASTM D698) for above foundations.	95% of standard Proctor maximum density
Water Content Range ^{3,4}	Low plasticity cohesive: -2% to +3% of optimum High plasticity cohesive: -1 to +4% of optimum Granular: -3% to +3% of optimum	As required to achieve min. compaction requirements

1. Structural and general fill should be placed and compacted in horizontal lifts, using equipment and procedures that will produce recommended moisture contents and densities throughout the lift. A construction disc or other suitable processing equipment will be needed to thoroughly process the materials and to aid in achieving uniform moisture content throughout the fill.
2. Care should be taken during the fill placement process to avoid zones of dissimilar fill. Improvements constructed over varying fill types are at a higher risk of differential movement compared to improvements over a uniform fill zone.
3. The contractor should expect significant moisture adjustment and processing of the site soils or import materials will be needed prior to or during compaction operations. In particular, the clayey sand encountered is expected to have in-place moisture contents below the soil's optimum moisture content. The contractor should expect considerable moisture adjustment of these soils will be needed prior to or during backfilling operations.
4. Moisture conditioned cohesive soils should not be allowed to dry out. A loss of moisture within these materials will likely result in an increase of the material's swell potential. Subsequent wetting of these material could result in undesirable movements.

Utility Trench Backfill

Any soft or unsuitable materials encountered at the bottom of utility trench excavations should be removed and replaced with structural fill or bedding material in accordance with public works specifications for the utility to be supported. This recommendation is particularly applicable to utility work requiring grade control and/or in areas where subsequent grade raising could cause settlement in the subgrade supporting the utility. Trench excavation should not be conducted below a downward 1:1 projection from existing foundations without engineering review of shoring requirements and geotechnical observation during construction.

On-site materials are considered suitable for backfill of utility and pipe trenches from 1 foot above the top of the pipe to the final ground surface, provided the material is free of organic matter and deleterious substances.

Trench backfill should be mechanically placed and compacted as discussed earlier in this report. Where trenches are placed beneath slabs or footings, the backfill should satisfy the gradation and expansion index requirements of engineered fill discussed in this report. Flooding or jetting for placement and compaction of backfill is not recommended.

Grading and Drainage

All grades must provide effective drainage away from the buildings during and after construction and should be maintained throughout the life of the structures. Water retained next to the buildings can result in soil movements greater than those discussed in this report. Greater movements can result in unacceptable differential floor slab and/or foundation movements, cracked slabs and walls, and roof leaks. The roof should have gutters/drains with downspouts that discharge onto splash blocks at a distance of at least 10 feet from the buildings.

Exposed ground should be sloped and maintained at a minimum 5% away from the buildings for at least 10 feet beyond the perimeter of the buildings. Flatter grades may be necessary to transition ADA access requirements for flatwork. After building construction and landscaping have been completed, final grades should be verified to document effective drainage has been achieved. Grades around the structures should also be periodically inspected and adjusted, as necessary, as part of the structures' maintenance program. Where paving or flatwork abuts the structures, a maintenance program should be established to effectively seal and maintain joints and prevent surface water infiltration.

Earthwork Construction Considerations

Excavations for the proposed structures are anticipated to be accomplished with conventional construction equipment. Upon completion of filling and grading, care should be taken to maintain the subgrade water content prior to construction of grade-supported improvements such as floor slabs and pavements. Construction traffic over the completed subgrades should be avoided. The site should also be graded to prevent ponding of surface water on the prepared subgrades or in excavations. Water collecting over or adjacent to construction areas should be removed. If the subgrade freezes, desiccates, saturates, or is disturbed, the affected material should be removed, or the materials should be scarified, moisture conditioned, and recompacted prior to floor slab construction.

As a minimum, excavations should be performed in accordance with OSHA 29 CFR, Part 1926, Subpart P, "Excavations" and its appendices, and in accordance with any applicable local and/or state regulations.

Construction site safety is the sole responsibility of the contractor who controls the means, methods, and sequencing of construction operations. Under no circumstances shall the information provided herein be interpreted to mean Terracon is assuming responsibility for construction site safety or the contractor's activities; such responsibility shall neither be implied nor inferred.

Excavations or other activities resulting in ground disturbance have the potential to affect adjoining properties and structures. Our scope of services does not include review of available final grading information or consider potential temporary grading performed by the contractor for potential effects such as ground movement beyond the project limits. A preconstruction/ precondition survey should be conducted to document nearby property/infrastructure prior to any site development activity. Excavation or ground disturbance activities adjacent or near property lines should be monitored or instrumented for potential ground movements that could negatively affect adjoining property and/or structures.

Construction Observation and Testing

The earthwork efforts should be observed by the Geotechnical Engineer (or others under their direction). Observation should include documentation of adequate removal of surficial materials (vegetation, topsoil, and various debris and stockpiles), evaluation and remediation of existing fill materials, as well as proofrolling and mitigation of unsuitable areas delineated by the proofroll.

Each lift of compacted fill should be tested, evaluated, and reworked, as necessary, as recommended by the Geotechnical Engineer prior to placement of additional lifts. Each lift of fill should be tested for density and water content at a frequency of at least one

test for every 2,500 square feet of compacted fill in the building areas and 5,000 square feet in pavement areas. Where not specified by local ordinance, one density and water content test should be performed for every 100 linear feet of compacted utility trench backfill and a minimum of one test performed for every 12 vertical inches of compacted backfill.

In areas of foundation excavations, the bearing subgrade should be evaluated by the Geotechnical Engineer. If unanticipated conditions are observed, the Geotechnical Engineer should prescribe mitigation options.

In addition to the documentation of the essential parameters necessary for construction, the continuation of the Geotechnical Engineer into the construction phase of the project provides the continuity to maintain the Geotechnical Engineer’s evaluation of subsurface conditions, including assessing variations and associated design changes.

Shallow Foundations

If the site has been prepared in accordance with the requirements noted in [Earthwork](#), the following design parameters are applicable for shallow foundations.

Design Parameters – Compressive Loads

Item	Description	
	Square Footing	Strip Footing
Maximum Net Allowable Bearing Pressure ^{1, 2}	4,000 psf ³	2,500 psf ³
Minimum embedment below finished grade ^{4,5}	36 inches	
Maximum foundation dimensions	7 feet	4 feet (wide)
Estimated Total Settlement from Structural Loads ²	About 1 inch	
Estimated Differential Settlement ^{2, 6}	About ½ to ¾ of total settlement	

1. The maximum net allowable bearing pressure is the pressure in excess of the minimum surrounding overburden pressure at the footing base elevation. Values assume exterior grades are no steeper than 20% within 10 feet of structures.
2. Values provided are for maximum loads noted in [Project Description](#). Additional geotechnical consultation will be necessary if higher loads are anticipated.

Item	Description	
	Square Footing	Strip Footing
3.	Provided existing fill is removed and replaced with newly placed structural fill below the foundation elements to provide uniform support and reduce the risk of movement.	
4.	Unsuitable loose or soft soils should be over-excavated and replaced per the recommendations presented in Earthwork .	
5.	Embedment necessary to minimize the effects of frost and/or seasonal water content variations. For sloping ground, maintain depth below the lowest adjacent exterior grade within 5 horizontal feet of the structures.	
6.	Differential settlements are noted for equivalent-loaded foundations and bearing elevation as measured over a span of 50 feet.	

Foundation Construction Considerations

As noted in **Earthwork**, the footing excavations should be evaluated under the observation of the Geotechnical Engineer. The base of all foundation excavations should be free of water and loose soil, prior to placing concrete. Concrete should be placed soon after excavating to reduce bearing soil disturbance. Care should be taken to prevent wetting or drying of the bearing materials during construction. Excessively wet or dry material or any loose/disturbed material in the bottom of the footing excavations should be removed/reconditioned before foundation concrete is placed.

Floor Slabs

Design parameters for floor slabs assume the requirements for **Earthwork** have been followed. Specific attention should be given to positive drainage away from the structures and positive drainage of the aggregate base beneath the floor slab. Existing fill was observed at the site to depths of about 1 to 6 feet below existing grade. As previously described, any existing fill present beneath floor slabs should be completely removed and reworked.

Floor Slab Design Parameters

Item	Description
Interior floor system	Slab-on-grade concrete.
Floor Slab Support¹	Existing fill removed and replaced with newly placed structural fill below the floor slabs to provide uniform support and reduce the risk of movement.

Item	Description
<p>Estimated Modulus of Subgrade Reaction ²</p>	<p>For limited area loads or concentrated/point loads placed directly on slabs:</p> <ul style="list-style-type: none"> ■ 150 pounds per square inch per inch (psi/in.) for slabs supported on compacted subgrade consisting of the on-sites soils. ■ 200 psi/in. for slabs supported on at least 6 inches of compacted aggregate base course.

1. Floor slabs should be structurally independent of building footings or walls to reduce the possibility of floor slab cracking caused by differential movements between the slab and foundation.
2. Modulus of subgrade reaction is an estimated value based upon our experience with the subgrade condition, the requirements noted in **Earthwork**, and the floor slab support as noted in this table. It is provided for point loads. For large area loads, the modulus of subgrade reaction would be lower.

The use of a vapor retarder should be considered beneath concrete slabs on grade covered with wood, tile, carpet, or other moisture sensitive or impervious coverings, when the project includes humidity-controlled areas, or when the slab will support equipment sensitive to moisture. When conditions warrant the use of a vapor retarder, the slab designer should refer to ACI 302 and/or ACI 360 for procedures and cautions regarding the use and placement of a vapor retarder.

Saw-cut contraction joints should be placed in the slab to help control the location and extent of cracking. For additional recommendations, refer to the ACI Design Manual. Joints or cracks should be sealed with a waterproof, non-extruding compressible compound specifically recommended for heavy duty concrete pavement and wet environments.

Where floor slabs are tied to perimeter walls or turn-down slabs to meet structural or other construction objectives, our experience indicates differential movement between the walls and slabs will likely be observed in adjacent slab expansion joints or floor slab cracks beyond the length of the structural dowels. The Structural Engineer should account for potential differential settlement through use of sufficient control joints, appropriate reinforcing or other means.

Settlement of floor slabs supported on existing fill materials cannot be accurately predicted but could be larger than normal and result in some cracking. Mitigation measures, as noted in **Existing Fill** within **Earthwork**, are critical to the performance of floor slabs. In addition to the mitigation measures, the floor slab can be stiffened by adding steel reinforcement, grade beams, and/or post-tensioned elements.

Floor Slab Construction Considerations

Finished subgrade, within and for at least 10 feet beyond the floor slab, should be protected from traffic, rutting, or other disturbance and maintained in a relatively moist condition until floor slabs are constructed. If the subgrade should become damaged or desiccated prior to construction of floor slabs, the affected material should be removed, and structural fill should be added to replace the resulting excavation. Final conditioning of the finished subgrade should be performed immediately prior to placement of the floor slab support course.

The Geotechnical Engineer should observe the condition of the floor slab subgrades immediately prior to placement of the floor slab support course, reinforcing steel, and concrete. Attention should be paid to high traffic areas that were rutted and disturbed earlier, and to areas where backfilled trenches are located.

Pavements

General Pavement Comments

Pavement designs are provided for the traffic conditions and pavement life conditions as noted in **Project Description** and in the following sections of this report. A critical aspect of pavement performance is site preparation. Pavement designs noted in this section must be applied to the site which has been prepared as recommended in the **Earthwork** section. Our opinion of the pavement section thickness design has been developed based on our understanding of the intended use, assumed traffic, and subgrade preparation recommended herein using methodology contained in ACI 330 "Guide to Design and Construction of Concrete Parking Lots" and NAPA IS-109 "Design of Hot Mix Asphalt Pavements."

Pavement Design Parameters

The design of flexible pavements for the project was based on the procedures of the National Asphalt Pavement Association (NAPA). These design procedures are specific to low-volume (low traffic) pavements such as those that will be constructed at this site.

The design of the recommended pavement sections was based on the following NAPA Criteria:

- NAPA Traffic Class II for main drives, light truck drives, and trash enclosures areas includes a maximum of 27,000 ESAL's over the design life of the pavement (Medium-Duty): Average Daily Truck Traffic (ADTT)=25,

- A soil characterization of “poor” based on the subsurface soils encountered at the site and expected at pavement subgrade elevation, and
- A pavement design life of 20 years.

Pavement Section Thicknesses

The following table provides the recommend minimum thickness for AC sections:

Asphaltic Concrete Design

Layer	Thickness (inches)
	Traffic Class I ¹
AC ²	4
Aggregate Base ³	6
Total	10

1. See [Pavement Design Parameters](#) for more specifics regarding traffic assumptions.
2. All materials should meet WYDOT (2021) Standard Specifications for Road and Bridge Construction.
3. Requirements specified in [Fill Material Types](#) section.

Areas for parking of heavy vehicles, concentrated turn areas, and start/stop maneuvers could require thicker pavement sections. Edge restraints (i.e. concrete curbs or aggregate shoulders) should be planned along curves and areas of maneuvering vehicles.

Openings in pavements, such as decorative landscaped areas, are sources for water infiltration into surrounding pavement systems. Water can collect in the islands and migrate into the surrounding subgrade soils thereby degrading support of the pavement. Islands with raised concrete curbs, irrigated foliage, and low permeability near-surface soils are particular areas of concern. The civil design for the pavements with these conditions should include features to restrict or collect and discharge excess water from the islands. Examples of features are edge drains connected to the stormwater collection system, longitudinal subdrains, or other suitable outlets and impermeable barriers preventing lateral migration of water such as a cutoff wall installed to a depth below the pavement structure.

Pavement Maintenance

The pavement section represents minimum recommended thicknesses and, as such, periodic upkeep should be anticipated. Preventive maintenance should be planned and provided for through an on-going pavement management program. Maintenance activities are intended to slow the rate of pavement deterioration and to preserve the pavement investment. Pavement care consists of both localized (e.g., crack and joint sealing and patching) and global maintenance (e.g., surface sealing). Additional engineering consultation is recommended to determine the type and extent of a cost-effective program. Even with periodic maintenance, some movements and related cracking may still occur, and repairs may be required.

Pavement performance is affected by its surroundings. In addition to providing preventive maintenance, the civil engineer should consider the following recommendations in the design and layout of pavements:

- Final grade adjacent to paved areas should slope down from the edges at a minimum 2%.
- Subgrade and pavement surfaces should have a minimum 2% slope to promote proper surface drainage.
- Install pavement drainage systems surrounding areas anticipated for frequent wetting.
- Install joint sealant and seal cracks immediately.
- Seal all landscaped areas in or adjacent to pavements to reduce moisture migration to subgrade soils.
- Place compacted, low permeability backfill against the exterior side of curb and gutter.
- Place curb, gutter and/or sidewalk directly on clay subgrade soils rather than on unbound granular base course materials.

Frost Considerations

The soils on this site are frost susceptible, and small amounts of water can affect the performance of the slabs on-grade, sidewalks, and pavements. Exterior slabs should be anticipated to heave during winter months. If frost action needs to be eliminated in critical areas, we recommend the use of non-frost susceptible (NFS) fill or structural slabs (for instance, structural stoops in front of building doors). Placement of NFS material in large areas may not be feasible; however, the following recommendations are provided to help reduce potential frost heave:

- Provide surface drainage away from the buildings and slabs, and toward the site drainage system.

- Install drains around the perimeter of the buildings, stoops, below exterior slabs and pavements, and connect them to the site drainage system.
- Grade clayey subgrades so groundwater potentially perched in overlying fill or aggregate base, slope toward a site drainage system.
- Place NFS fill as backfill beneath slabs and pavements critical to the project.
- Place a 3 horizontal to 1 vertical (3H:1V) transition zone between NFS fill and other soils.
- Place NFS materials in critical sidewalk areas.

As an alternative to extending NFS fill to the full frost depth, consideration can be made to placing extruded polystyrene or cellular concrete under a buffer of at least 2 feet of NFS material.

General Comments

Our analysis and opinions are based upon our understanding of the project, the geotechnical conditions in the area, and the data obtained from our site exploration. Variations will occur between exploration point locations or due to the modifying effects of construction or weather. The nature and extent of such variations may not become evident until during or after construction. Terracon should be retained as the Geotechnical Engineer, where noted in this report, to provide observation and testing services during pertinent construction phases. If variations appear, we can provide further evaluation and supplemental recommendations. If variations are noted in the absence of our observation and testing services on-site, we should be immediately notified so that we can provide evaluation and supplemental recommendations.

Our Scope of Services does not include either specifically or by implication any environmental or biological (e.g., mold, fungi, bacteria) assessment of the site or identification or prevention of pollutants, hazardous materials or conditions. If the owner is concerned about the potential for such contamination or pollution, other studies should be undertaken.

Our services and any correspondence are intended for the sole benefit and exclusive use of our client for specific application to the project discussed and are accomplished in accordance with generally accepted geotechnical engineering practices with no third-party beneficiaries intended. Any third-party access to services or correspondence is solely for information purposes to support the services provided by Terracon to our client. Reliance upon the services and any work product is limited to our client and is not intended for third parties. Any use or reliance of the provided information by third parties is done solely at their own risk. No warranties, either express or implied, are intended or made.

Site characteristics as provided are for design purposes and not to estimate excavation cost. Any use of our report in that regard is done at the sole risk of the excavating cost estimator as there may be variations on the site that are not apparent in the data that could significantly effect excavation cost. Any parties charged with estimating excavation costs should seek their own site characterization for specific purposes to obtain the specific level of detail necessary for costing. Site safety and cost estimating including excavation support and dewatering requirements/design are the responsibility of others. Construction and site development have the potential to affect adjacent properties. Such impacts can include damages due to vibration, modification of groundwater/surface water flow during construction, foundation movement due to undermining or subsidence from excavation, as well as noise or air quality concerns. Evaluation of these items on nearby properties are commonly associated with contractor means and methods and are not addressed in this report. The owner and contractor should consider a preconstruction/precondition survey of surrounding development. If changes in the nature, design, or location of the project are planned, our conclusions and recommendations shall not be considered valid unless we review the changes and either verify or modify our conclusions in writing.

Geotechnical Engineering Report

Grand View Property | Laramie, Wyoming

June 10, 2024 | Terracon Project No. 24245022







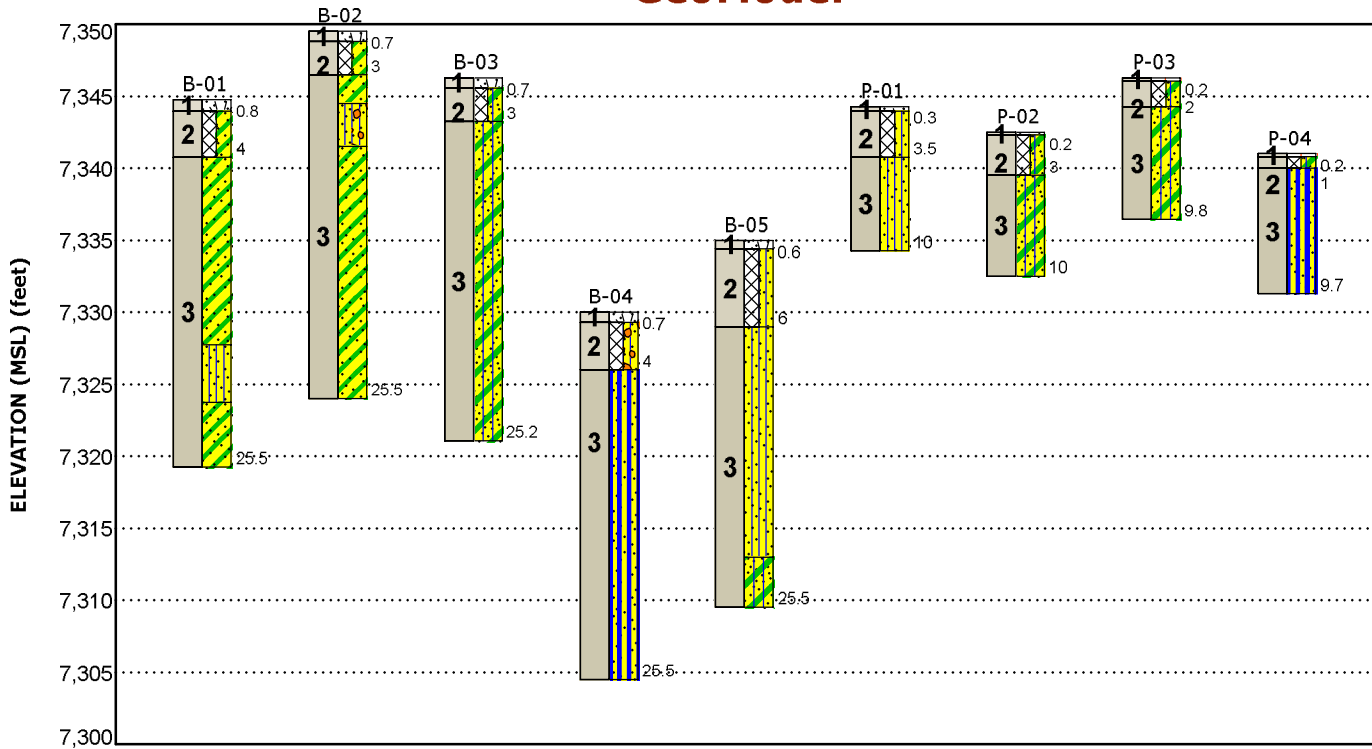

Figures

GeoModel

GeoModel



This is not a cross section. This is intended to display the Geotechnical Model only. See individual logs for more detailed conditions.

Model Layer	Layer Name	General Description	Legend	
1	Surficial Material	About 3 to 10 inches of vegetative soil and root penetration. About 3 inches of apparent aggregate base course in Boring Nos. P-03 and P-04.	 Vegetative Soil	 Clayey Sand
2	Existing Fill	Fine to coarse grain sands with vary amounts of silt, clay, and fine to coarse grained gravel. Reddish brown to red.	 Silty Sand	 Silty Sand with Gravel
3	Native Soil	Medium dense to dense sand with varying amounts of silt, clay and gravel. Fine to coarse grained sand and gravel. Very stiff to hard sandy silt, fine grained to medium grained. Generally reddish brown to red.	 Silty Clayey Sand	 Sandy Silt
			 Apparent Base Course	

NOTES:

Layering shown on this figure has been developed by the geotechnical engineer for purposes of modeling the subsurface conditions as required for the subsequent geotechnical engineering for this project.
 Numbers adjacent to soil column indicate depth below ground surface.

Geotechnical Engineering Report

Grand View Property | Laramie, Wyoming

June 10, 2024 | Terracon Project No. 24245022



Attachments

Exploration and Testing Procedures

Site Location and Exploration Plans

Exploration and Laboratory Results

Supporting Information

Exploration and Testing Procedures

Field Exploration

Number of Borings	Approximate Boring Depth (feet)	Location
5	25.5	Building areas
4	About 10	Parking/ driveway areas

Boring Layout and Elevations: Terracon personnel provided the boring layout using handheld GPS equipment (estimated horizontal accuracy of about ± 10 feet) and referencing existing site features. Approximate ground surface elevations were obtained by interpolation from the provided topographical map. If ground surface elevations and a more precise boring layout are desired, we recommend borings be surveyed.

Subsurface Exploration Procedures: We advanced the borings with a truck-mounted, drill rig using solid-stem, continuous-flight augers. Four samples were obtained in the upper 10 feet of each boring and at intervals of 5 feet thereafter. Soil sampling was typically performed using modified California barrel and split-barrel sampling procedures. In the split-barrel sampling procedure, a standard 2-inch outer diameter split-barrel sampling spoon was driven into the ground by a 140-pound automatic hammer falling a distance of 30 inches. The number of blows required to advance the sampling spoon the last 12 inches of a normal 18-inch penetration is recorded as the Standard Penetration Test (SPT) resistance value. Modified California barrel sampling procedures are similar to standard split spoon sampling procedure; however, blow counts are typically recorded for 6-inch intervals for a total of 12 inches of penetration. The SPT resistance values, also referred to as N-values, are indicated on the boring logs at the test depths. Additionally, bulk samples were collected at select boring locations from depths of approximately 1 to 5 feet below the ground surface.

We also observed the boreholes while drilling and at the completion of drilling for the presence of groundwater. Groundwater was not observed at these times in the boreholes.

The sampling depths, penetration distances, and other sampling information was recorded on the field boring logs. The samples were placed in appropriate containers and taken to our soil laboratory for testing and classification by a Geotechnical Engineer. Our exploration team prepared field boring logs as part of the drilling operations. These field logs included visual classifications of the materials observed during drilling and our interpretation of the subsurface conditions between samples. Final boring logs were prepared from the field logs. The final boring logs represent the Geotechnical Engineer's

interpretation of the field logs and include modifications based on observations and tests of the samples in our laboratory.

Laboratory Testing

The project engineer reviewed the field data and assigned laboratory tests. The laboratory testing program included the following types of tests:

- Moisture content
- Dry unit weight
- Atterberg limits
- Grain size analysis
- Swell consolidation
- Chemical analysis: pH, sulfates, sulfides, chlorides, RedOx, total salts, and electrical resistivity

The laboratory testing program often included examination of soil samples by an engineer. Based on the results of our field and laboratory programs, we described and classified the soil samples in accordance with the Unified Soil Classification System.

Site Location and Exploration Plans

Contents:

Site Location Plan

Exploration Plan

Note: All attachments are one page unless noted above.

Site Location

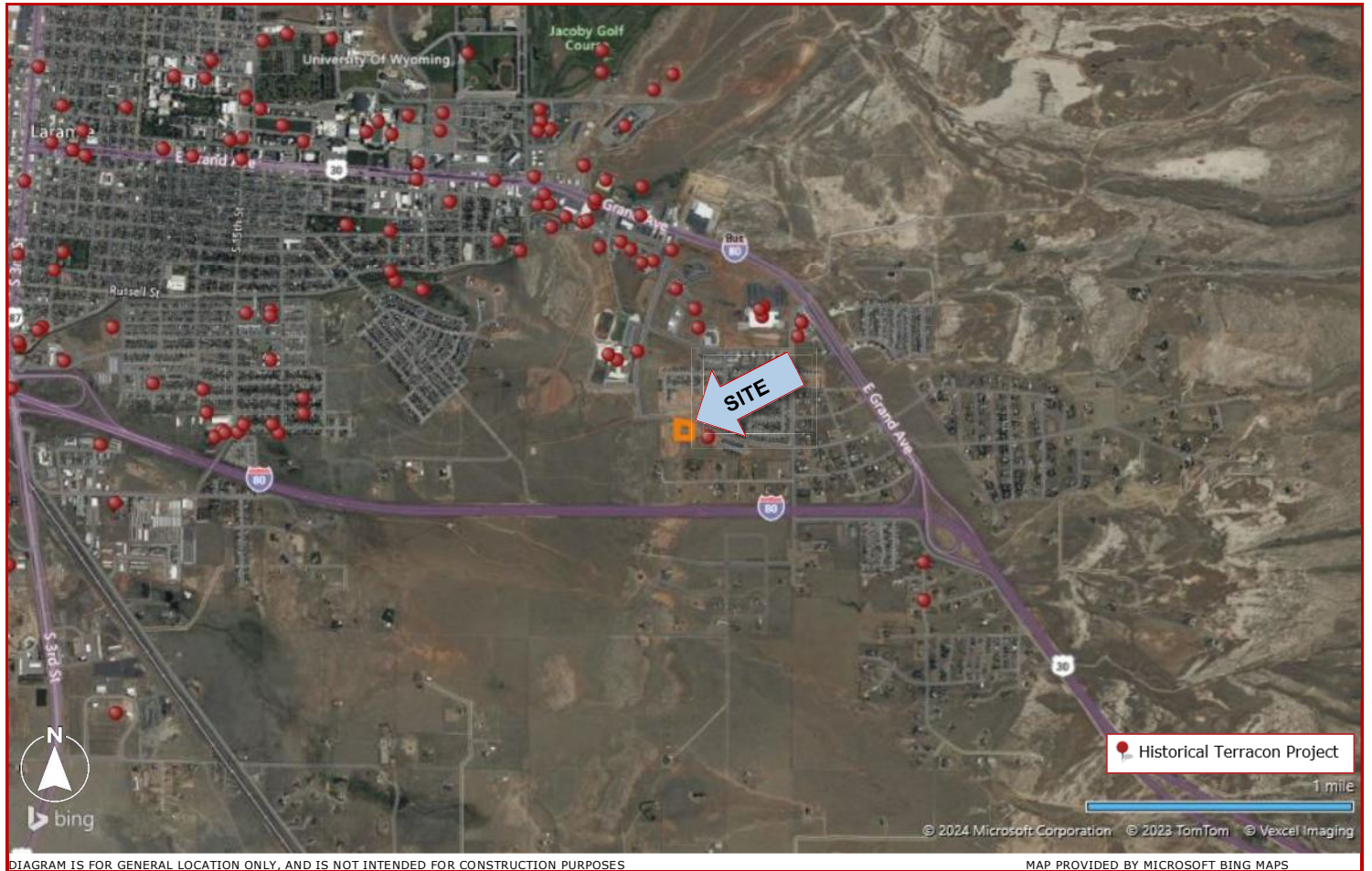

Exploration Plan

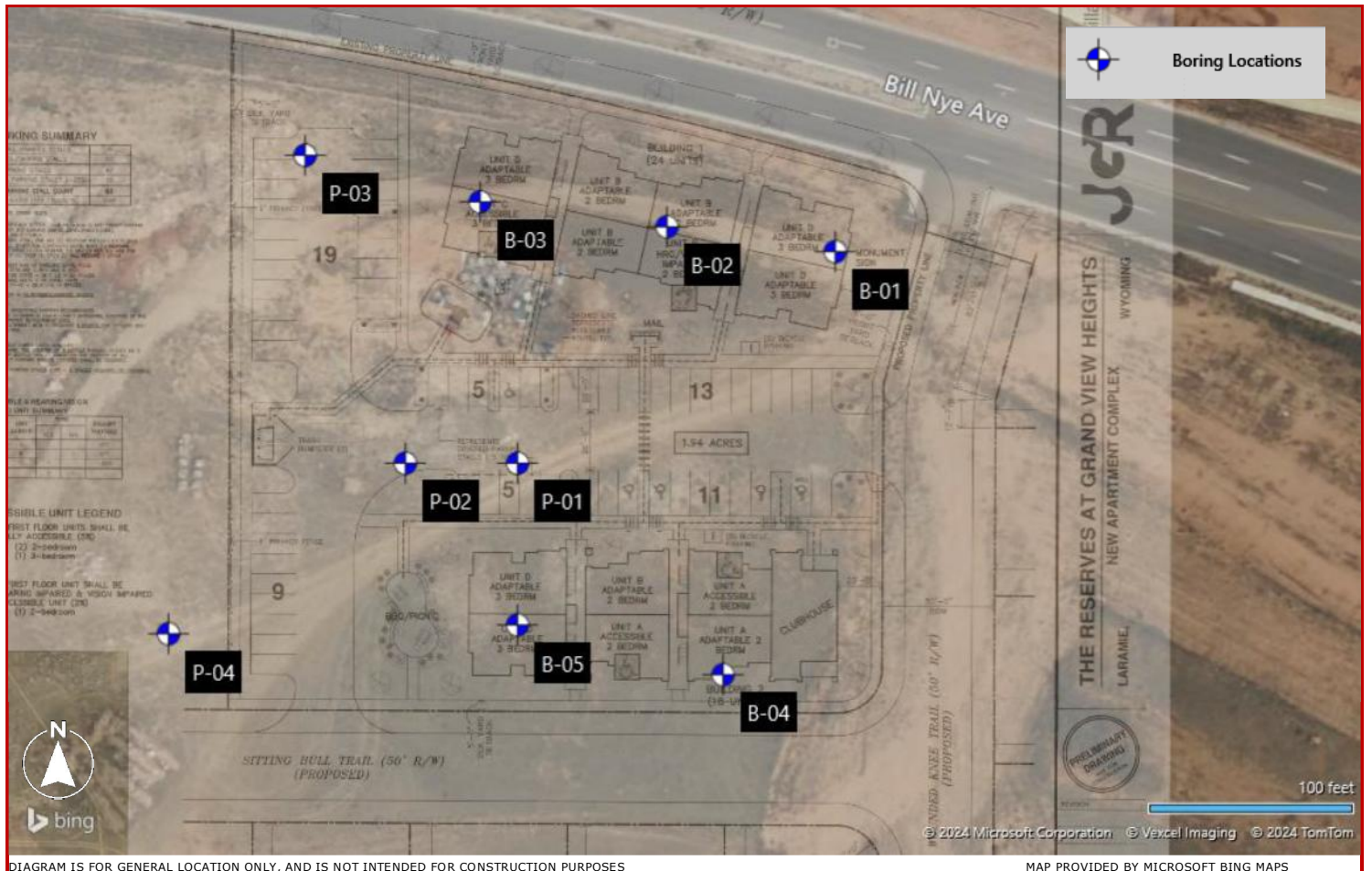

DIAGRAM IS FOR GENERAL LOCATION ONLY, AND IS NOT INTENDED FOR CONSTRUCTION PURPOSES

Exploration and Laboratory Results

Contents:

Boring Logs (B-01 through P-04)
Atterberg Limits
Grain Size Distribution
Consolidation/Swell
Corrosivity

Note: All attachments are one page unless noted above.

Boring Log No. B-01

Model Layer	Graphic Log	Location: See Exploration Plan Latitude: 41.2958° Longitude: -105.5456° Depth (Ft.) Elevation: 7344.75 (Ft.) +/-	Depth (Ft.)	Water Level Observations	Sample Type	Field Test Results	Swell- Consol / Load (%/psf)	Water Content (%)	Dry Unit Weight (pcf)	Atterberg Limits	
										LL-PL-PI	Percent Fines
1		VEGETATIVE SOIL , about 10 inches of root penetration	0.8			3-5-13 N=18		7.8			
2		FILL - CLAYEY SAND (SC) , trace silt, fine to medium grained, reddish brown to red	4.0			28/12"		7.9	113		
3		CLAYEY SAND (SC) , trace silt, fine to medium grained, reddish brown to red, medium dense to dense	5								
			7			7-7-34 N=41		8.3			
			10			16/12"		7.3	107		
			15			11-17-19 N=36		9.7			
			17.0								
		SILTY SAND (SM) , fine to medium grained, gray, very dense	17.0			50/3"		5.7	100		
		CLAYEY SAND (SC) , fine to coarse grained, reddish brown to red, dense	21.0								
			25.5			10-14-26 N=40		11.2			
		Boring Terminated at 25.5 Feet	25.5								

See [Exploration and Testing Procedures](#) for a description of field and laboratory procedures used and additional data (if any).

See [Supporting Information](#) for explanation of symbols and abbreviations.

Elevation Reference: Elevations were interpolated from the provided topographic site plan.

Notes

Water Level Observations

None encountered while drilling

Drill Rig

CME 55

Hammer Type

Automatic

Driller

Terracon Consultants Inc.
 Hammer Efficiency = 67.7%

Boring Started

04-29-2024

Boring Completed

04-29-2024







Advancement Method

4-inch diameter, solid-stem auger

Abandonment Method

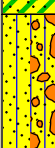
Boring backfilled with auger cuttings upon completion.

Boring Log No. B-02

Model Layer	Graphic Log	Location: See Exploration Plan Latitude: 41.2958° Longitude: -105.5459°	Depth (Ft.)	Elevation: 7349.5 (Ft.) +/-	Water Level Observations	Sample Type	Field Test Results	Swell- Consol / Load (%/psf)	Water Content (%)	Dry Unit Weight (pcf)	Atterberg Limits	
											LL-PL-PI	Percent Fines
1		VEGETATIVE SOIL , about 8 inches of root penetration	0.7	7348.8			3-4-6 N=10		10.5			
2		FILL - CLAYEY SAND (SC) , fine to coarse grained, reddish brown to red	3.0	7346.5								
3		CLAYEY SAND (SC) , fine to coarse grained, reddish brown to red, medium dense	5.0	7344.5			16/12"	-0.5/500	5.6	104		
		SILTY SAND WITH GRAVEL (SM) , fine to coarse grained sand, fine grained gravel, reddish brown to red, medium dense	8.0	7341.5			4-6-9 N=15		7.9		NP	47
		CLAYEY SAND (SC) , trace silt, fine to coarse grained, reddish brown to red, medium dense to dense						38/12"	7.0			
												
												
		Weak cementation at about 19 feet, very dense					10-10-6 N=16		7.6			
							8-50/2"		6.7	110		
							10-12-24 N=36		9.0			
		Boring Terminated at 25.5 Feet	25.5	7324								

See [Exploration and Testing Procedures](#) for a description of field and laboratory procedures used and additional data (if any).
 See [Supporting Information](#) for explanation of symbols and abbreviations.
 Elevation Reference: Elevations were interpolated from the provided topographic site plan.

Notes

Water Level Observations
 None encountered while drilling

Drill Rig
 CME 55

Hammer Type
 Automatic

Driller
 Terracon Consultants Inc.
 Hammer Efficiency = 67.7%



Boring Started
 04-29-2024

Boring Completed
 04-29-2024

Advancement Method
 4-inch diameter, solid-stem auger

Abandonment Method
 Boring backfilled with auger cuttings upon completion.

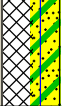
Boring Log No. B-03

Model Layer	Graphic Log	Location: See Exploration Plan Latitude: 41.2958° Longitude: -105.5462°	Depth (Ft.)	Elevation: 7346.25 (Ft.) +/-	Water Level Observations	Sample Type	Field Test Results	Swell- Consol / Load (%/psf)	Water Content (%)	Dry Unit Weight (pcf)	Atterberg Limits	
											LL-PL-PI	Percent Fines
1		VEGETATIVE SOIL , about 9 inches of root penetration	0.7	7345.55			3-5-6 N=11		10.5			
2		FILL - SILTY CLAYEY SAND (SC-SM) , trace fine grained gravel, fine to coarse grained sand, reddish brown to red	3.0	7343.25								
3		SILTY CLAYEY SAND (SC-SM) , trace fine grained gravel, fine to coarse grained sand, reddish brown to red, medium dense to very dense Calcareous nodules at about 6 feet Moderate cementation at about 19 feet					28/12"		8.6			
							9-14-19 N=33		5.6			
							50/6"		7.8	105		
							50/5"		7.3			
							50/5"		9.0	106		
			25.2	7321.05			11-22-50/3"		9.0			
Boring Terminated at 25.2 Feet												

See [Exploration and Testing Procedures](#) for a description of field and laboratory procedures used and additional data (If any).
 See [Supporting Information](#) for explanation of symbols and abbreviations.
 Elevation Reference: Elevations were interpolated from the provided topographic site plan.

Notes

Water Level Observations
 None encountered while drilling

Drill Rig
 CME 55

Hammer Type
 Automatic

Driller
 Terracon Consultants Inc.
 Hammer Efficiency = 67.7%

Boring Started
 04-29-2024

Boring Completed
 04-29-2024

Advancement Method
 4-inch diameter, solid-stem auger

Abandonment Method
 Boring backfilled with auger cuttings upon completion.

Boring Log No. B-04

Model Layer	Graphic Log	Location: See Exploration Plan Latitude: 41.2959° Longitude: -105.5465° Depth (Ft.) Elevation: 7330 (Ft.) +/-	Depth (Ft.)	Water Level Observations	Sample Type	Field Test Results	Swell- Consol / Load (%/psf)	Water Content (%)	Dry Unit Weight (pcf)	Atterberg Limits		
										LL-PL-PI	Percent Fines	
1		VEGETATIVE SOIL , about 8 inches of root penetration	0.7			2-2-2 N=4		7.6				
2		FILL - SILTY SAND WITH GRAVEL (SM) , fine to coarse grained sand and gravel, reddish brown to red	4.0			35/12"		4.2		NP	43	
3		SANDY SILT (ML) , fine to coarse grained sand, fine grained gravel, reddish brown to red, hard Weak cementation at about 9 feet Weak cementation at about 19 feet	5			14-20-22 N=42		3.5				
			10			70/12"		4.0		NP	52	
			15			27-50/5"		10.6				
			20			14-50/5"		11.0	126			
			25			12-19-25 N=44		10.1				
Boring Terminated at 25.5 Feet			25.5									

See [Exploration and Testing Procedures](#) for a description of field and laboratory procedures used and additional data (if any).
 See [Supporting Information](#) for explanation of symbols and abbreviations.
 Elevation Reference: Elevations were interpolated from the provided topographic site plan.

Notes

Water Level Observations
 None encountered while drilling

Drill Rig
 CME 55

Hammer Type
 Automatic

Driller
 Terracon Consultants Inc.
 Hammer Efficiency = 67.7%

Boring Started
 04-29-2024

Boring Completed
 04-29-2024

Advancement Method
 4-inch diameter, solid-stem auger

Abandonment Method
 Boring backfilled with auger cuttings upon completion.

Boring Log No. B-05

Model Layer	Graphic Log	Location: See Exploration Plan Latitude: 41.2955° Longitude: -105.5462° Depth (Ft.) Elevation: 7335 (Ft.) +/-	Depth (Ft.)	Water Level Observations	Sample Type	Field Test Results	Swell- Consol / Load (%/psf)	Water Content (%)	Dry Unit Weight (pcf)	Atterberg Limits		
										LL-PL-PI	Percent Fines	
1		VEGETATIVE SOIL , about 7 inches of root penetration 7334.4	0.6			2-2-2 N=4		9.4				
2		FILL - SILTY SAND (SM) , fine to coarse grained sand, fine grained gravel, reddish brown to red 7329	6.0			31/12"		3.7		NP	39	
3		SILTY SAND (SM) , trace clay, fine to coarse grained sand, fine grained gravel, reddish brown to red, medium dense to dense 7313	6.0			9-12-14 N=26		9.8				
			10			26/12"		3.7				
			15			15-19-21 N=40		8.4				
			20	Calcareous nodules at about 19 feet			43/12"		9.9	120		
			22.0									
		SILTY CLAYEY SAND (SC-SM) , fine to coarse grained sand, fine grained gravel, reddish brown to red, dense 7309.5	22.0			9-16-18 N=34		9.2				
		Boring Terminated at 25.5 Feet	25.5									

See [Exploration and Testing Procedures](#) for a description of field and laboratory procedures used and additional data (If any).
 See [Supporting Information](#) for explanation of symbols and abbreviations.
 Elevation Reference: Elevations were interpolated from the provided topographic site plan.

Notes

Water Level Observations
 None encountered while drilling

Drill Rig
 CME 55

Hammer Type
 Automatic

Driller
 Terracon Consultants Inc.
 Hammer Efficiency = 67.7%

Boring Started
 04-29-2024

Boring Completed
 04-29-2024

Advancement Method
 4-inch diameter, solid-stem auger

Abandonment Method
 Boring backfilled with auger cuttings upon completion.

Boring Log No. P-01

Model Layer	Graphic Log	Location: See Exploration Plan Latitude: 41.2955° Longitude: -105.5464°	Depth (Ft.)	Elevation: 7344.25 (Ft.) +/-	Water Level Observations	Sample Type	Field Test Results	Swell- Consol / Load (%/psf)	Water Content (%)	Dry Unit Weight (pcf)	Atterberg Limits	
											LL-PL-PI	Percent Fines
1	[Cross-hatch pattern]	0.3	7343.95				3-6-9 N=15		11.4			
2	[Dotted pattern]											
		3.5	7340.75		[Black diamond]		14/12"		3.0			
3	[Dotted pattern]											
		10.0	7334.25	10	[Black diamond]		36/12"		6.7			
Boring Terminated at 10 Feet												

See [Exploration and Testing Procedures](#) for a description of field and laboratory procedures used and additional data (If any).
 See [Supporting Information](#) for explanation of symbols and abbreviations.
 Elevation Reference: Elevations were interpolated from the provided topographic site plan.

Notes

Water Level Observations
 None encountered while drilling

Drill Rig
 CME 55

Hammer Type
 Automatic

Driller
 Terracon Consultants Inc.
 Hammer Efficiency = 67.7%

Boring Started
 04-29-2024

Boring Completed
 04-29-2024

Advancement Method
 4-inch diameter, solid-stem auger

Abandonment Method
 Boring backfilled with auger cuttings upon completion.

Boring Log No. P-02

Model Layer	Graphic Log	Location: See Exploration Plan Latitude: 41.2952° Longitude: -105.5458°	Depth (Ft.)	Elevation: 7342.5 (Ft.) +/-	Water Level Observations	Sample Type	Field Test Results	Swell- Consol / Load (%/psf)	Water Content (%)	Dry Unit Weight (pcf)	Atterberg Limits	
											LL-PL-PI	Percent Fines
1		Depth (Ft.)	0.2	7342.3								
2		VEGETATIVE SOIL , about 3 inches of root penetration					3-3-4 N=7		7.4			
		FILL - SILTY CLAYEY SAND (SC-SM) , fine to coarse grained, reddish brown to red										
			3.0	7339.5			25/12"		3.5	105		
3		SILTY CLAYEY SAND (SC-SM) , trace fine grained gravel, fine to coarse grained sand, reddish brown to red, medium dense to dense										
							14-20-25 N=45		5.8			
		Weakly cemented lens at about 9 feet										
			10.0	7332.5			67/12"		7.7			
Boring Terminated at 10 Feet												

See [Exploration and Testing Procedures](#) for a description of field and laboratory procedures used and additional data (if any).
 See [Supporting Information](#) for explanation of symbols and abbreviations.
 Elevation Reference: Elevations were interpolated from the provided topographic site plan.

Notes

Water Level Observations

None encountered while drilling

Drill Rig
CME 55

Hammer Type
Automatic

Driller
Terracon Consultants Inc.
Hammer Efficiency = 67.7%

Boring Started
04-29-2024

Boring Completed
04-29-2024

Advancement Method

4-inch diameter, solid-stem auger

Abandonment Method

Boring backfilled with auger cuttings upon completion.

Boring Log No. P-03

Model Layer	Graphic Log	Location: See Exploration Plan Latitude: 41.2953° Longitude: -105.5462°	Depth (Ft.)	Elevation: 7346.25 (Ft.) +/-	Water Level Observations	Sample Type	Field Test Results	Swell- Consol / Load (%/psf)	Water Content (%)	Dry Unit Weight (pcf)	Atterberg Limits	
											LL-PL-PI	Percent Fines
1		0.2	0.2	7346.05								
2		APPARENT BASE COURSE , about 3 inches FILL - SILTY CLAYEY SAND (SC-SM) , fine to medium grained, reddish brown to red	2.0	7344.25			2-2-7 N=9		18.4			
3		SILTY CLAYEY SAND (SC-SM) , trace fine grained gravel, fine to coarse grained sand, reddish brown to red, medium dense to very dense										
		Moderate cementation at about 9 feet	9.8	7336.45			30/12"		6.3	108		
		Boring Terminated at 9.8 Feet					12-16-23 N=39		7.5			
							7-50/4"		8.2			

See [Exploration and Testing Procedures](#) for a description of field and laboratory procedures used and additional data (if any).
 See [Supporting Information](#) for explanation of symbols and abbreviations.
 Elevation Reference: Elevations were interpolated from the provided topographic site plan.

Notes

Water Level Observations
 None encountered while drilling

Drill Rig
 CME 55

Hammer Type
 Automatic

Driller
 Terracon Consultants Inc.
 Hammer Efficiency = 67.7%

Boring Started
 04-29-2024

Boring Completed
 04-29-2024

Advancement Method
 4-inch diameter, solid-stem auger

Abandonment Method
 Boring backfilled with auger cuttings upon completion.

Boring Log No. P-04

Model Layer	Graphic Log	Location: See Exploration Plan Latitude: 41.2953° Longitude: -105.5468°	Depth (Ft.)	Elevation: 7341 (Ft.) +/-	Water Level Observations	Sample Type	Field Test Results	Swell- Consol / Load (%/psf)	Water Content (%)	Dry Unit Weight (pcf)	Atterberg Limits	
											LL-PL-PI	Percent Fines
1		0.2 APPARENT BASE COURSE, about 3 inches	0.2	7340.8								
2		1.0 FILL - SILTY CLAYEY SAND (SC-SM), fine to medium grained, reddish brown to red	1.0	7340			7-7-6 N=13		7.3			
3		SANDY SILT (ML), fine to medium grained sand, reddish brown to red, very stiff to hard										
		Weak cementation at about 9 feet	9.7	7331.3			30-50/3"		7.0	111		
Boring Terminated at 9.7 Feet												

See [Exploration and Testing Procedures](#) for a description of field and laboratory procedures used and additional data (If any).
 See [Supporting Information](#) for explanation of symbols and abbreviations.
 Elevation Reference: Elevations were interpolated from the provided topographic site plan.

Notes

Water Level Observations
 None encountered while drilling

Drill Rig
 CME 55

Hammer Type
 Automatic

Driller
 Terracon Consultants Inc.
 Hammer Efficiency = 67.7%

Boring Started
 04-29-2024

Boring Completed
 04-29-2024

Advancement Method
 4-inch diameter, solid-stem auger

Abandonment Method
 Boring backfilled with auger cuttings upon completion.

Atterberg Limit Results ASTM D4318

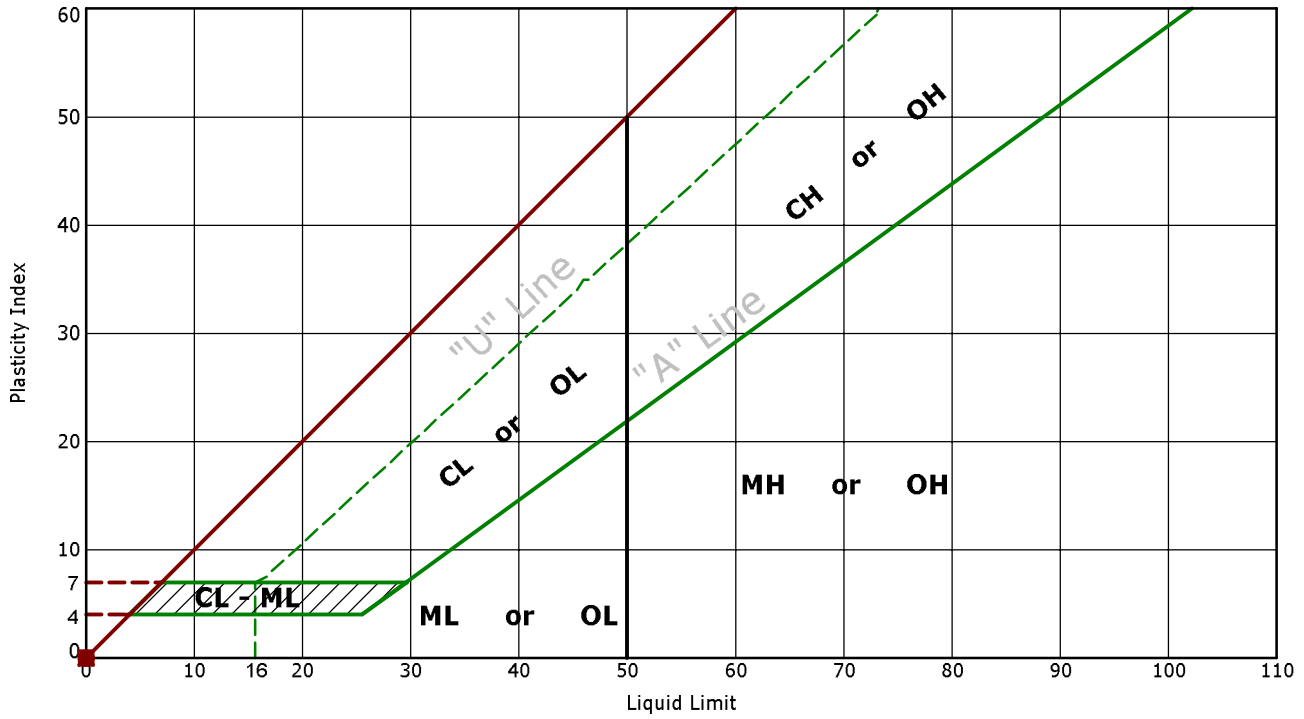

	Boring ID	Depth (Ft)	LL	PL	PI	Fines	USCS	Description
●	B-02	6 - 7.5	NP	NP	NP	46.9	SM	SILTY SAND with GRAVEL
☒	B-04	3 - 4	NP	NP	NP	42.9	SM	SILTY SAND with GRAVEL
▲	B-04	9 - 10	NP	NP	NP	52.3	ML	SANDY SILT
★	B-05	3 - 4	NP	NP	NP	39.1	SM	SILTY SAND

Grain Size Distribution

ASTM D422 / ASTM C136

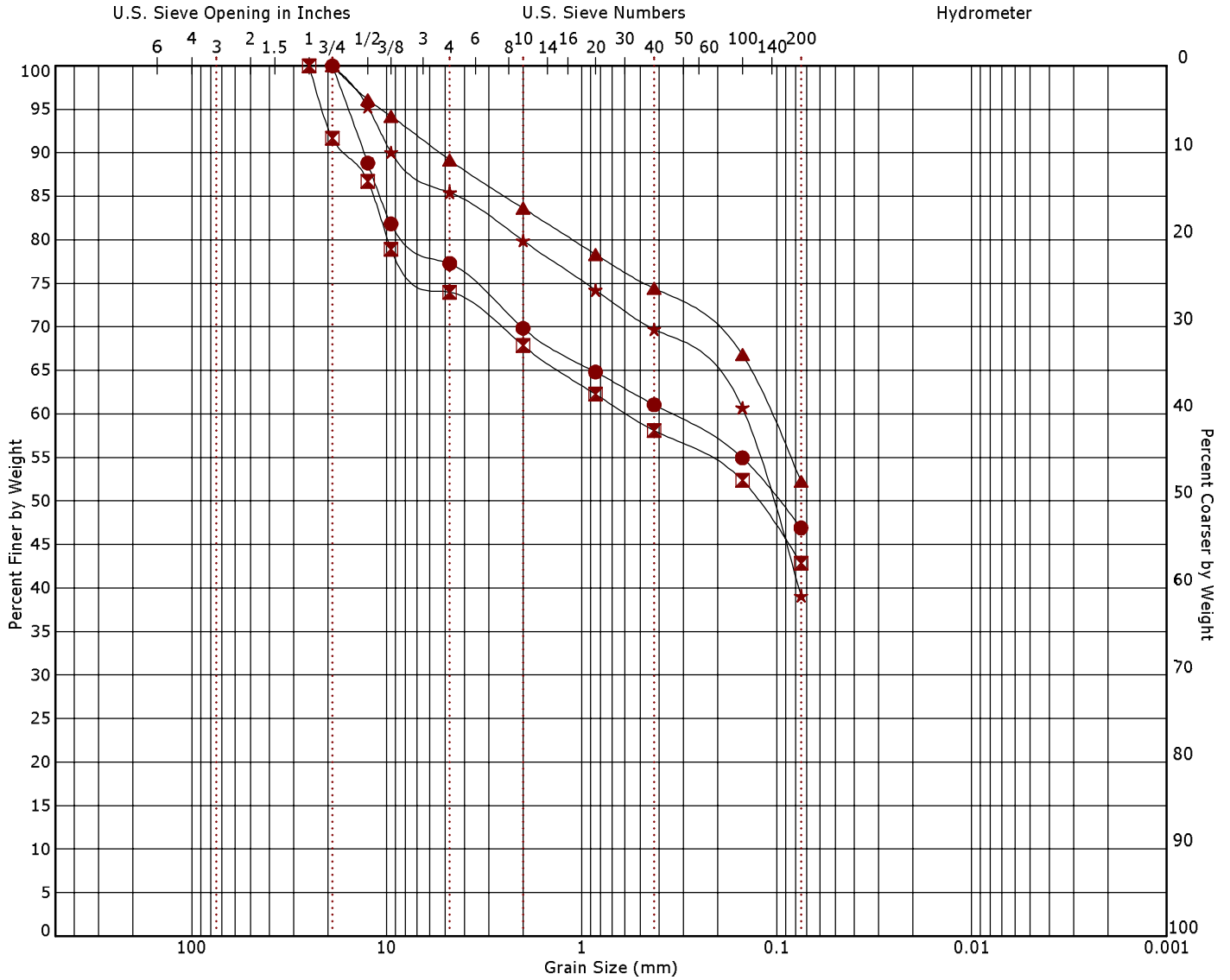

Cobbles |
 Gravel |
 Sand |
 Silt or Clay

coarse | fine | coarse | medium | fine

Boring ID	Depth (Ft)	USCS Classification	USCS	AASHTO	LL	PL	PI	Cc	Cu
● B-02	6 - 7.5	SILTY SAND with GRAVEL	SM	A-4 (0)	NP	NP	NP		
☒ B-04	3 - 4	SILTY SAND with GRAVEL	SM	A-4 (0)	NP	NP	NP		
▲ B-04	9 - 10	SANDY SILT	ML	A-4 (0)	NP	NP	NP		
★ B-05	3 - 4	SILTY SAND	SM	A-4 (0)	NP	NP	NP		

Boring ID	Depth (Ft)	D ₁₀₀	D ₆₀	D ₃₀	D ₁₀	%Cobbles	%Gravel	%Sand	%Fines	%Silt	%Clay
● B-02	6 - 7.5	19	0.355			0.0	22.7	30.4	46.9		
☒ B-04	3 - 4	25	0.584			0.0	26.0	31.1	42.9		
▲ B-04	9 - 10	19	0.108			0.0	10.8	36.9	52.3		
★ B-05	3 - 4	19	0.147			0.0	14.5	46.4	39.1		

One-Dimensional Swell or Collapse

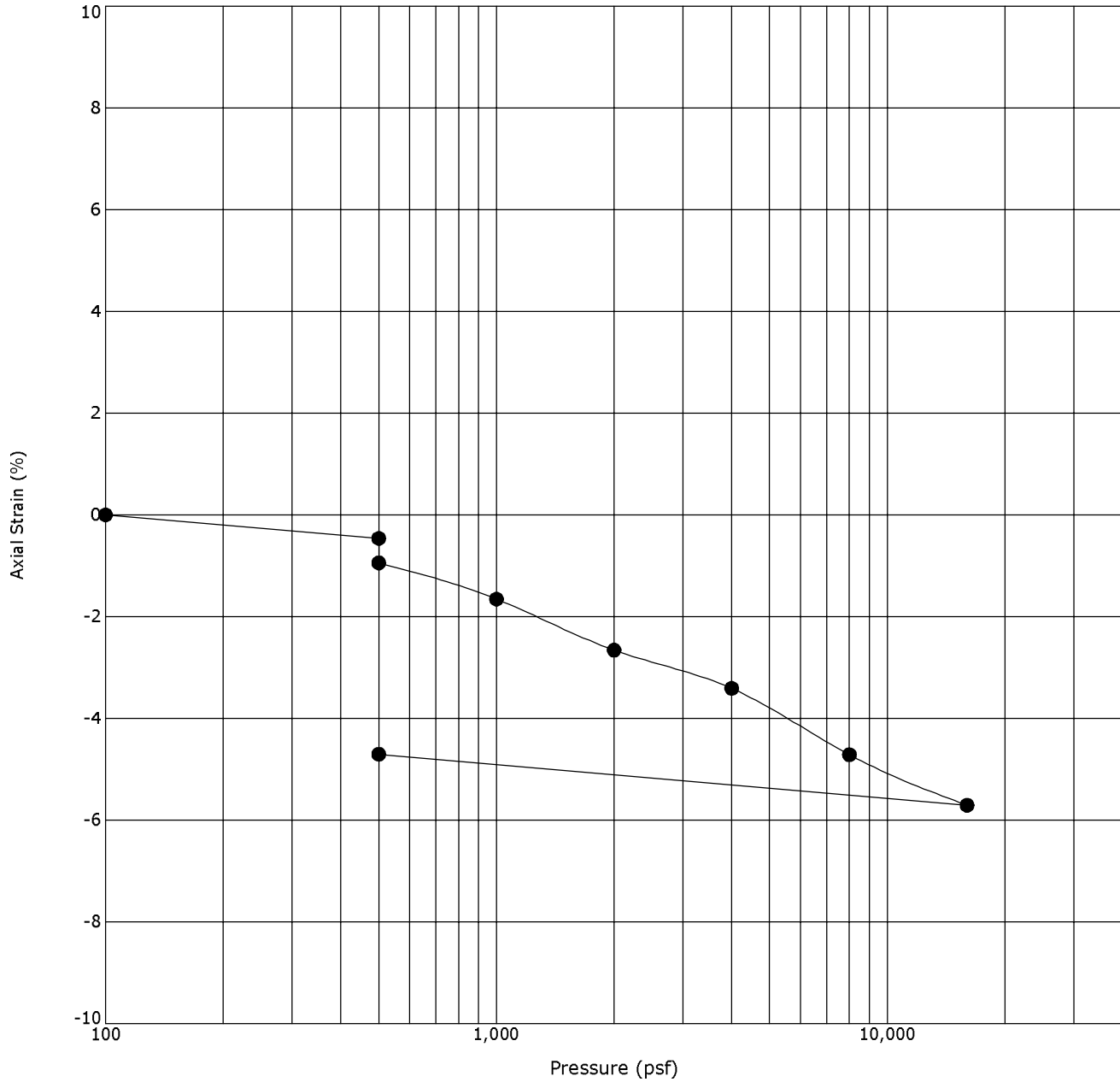

Boring ID	Depth (Ft)	Description	USCS	γ_d (pcf)	WC (%)
● B-02	3 - 4	CLAYEY SAND	SC	110	5.2

Notes: Sample exhibited 0.5 percent compression when wetted under an applied pressure of 500 psf

CHEMICAL LABORATORY TEST REPORT

Project Number: 24245022
Service Date: 5/27/2024
Report Date: 5/27/2024



1505 Old Happy Jack Road
Cheyenne, Wyoming 82001
(307) 632-9224

Project: Grand View Property

Sample Location	<u>B-5</u>
Sample Depth (ft.)	<u>1-5</u>
pH Analysis, ASTM - G51	<u>6.0</u>
Water Soluble Sulfate (SO4), ASTM C1580 (mg/kg)	<u>23</u>
Sulfides, ASTM - D4658 (mg/kg)	<u>0</u>
Chlorides, ASTM - D512 (mg/kg)	<u>20</u>
RedOx, ASTM - D1498 (mV)	<u>+239</u>
Total Salts, ASTM - D1125 (mg/kg)	<u>1,669</u>
Resistivity, ASTM - G187 (ohm-cm)	<u>5,225</u>

Reviewed By:

Seth Winter
Laboratory Supervisor

Supporting Information







Contents:

General Notes

Unified Soil Classification System

Note: All attachments are one page unless noted above.

General Notes

Sampling	Water Level	Field Tests
 Auger Cuttings  Modified California Ring Sampler  Standard Penetration Test	 Water Initially Encountered  Water Level After a Specified Period of Time  Water Level After a Specified Period of Time  Cave In Encountered <p>Water levels indicated on the soil boring logs are the levels measured in the borehole at the times indicated. Groundwater level variations will occur over time. In low permeability soils, accurate determination of groundwater levels is not possible with short term water level observations.</p>	N Standard Penetration Test Resistance (Blows/Ft.) (HP) Hand Penetrometer (T) Torvane (DCP) Dynamic Cone Penetrometer UC Unconfined Compressive Strength (PID) Photo-Ionization Detector (OVA) Organic Vapor Analyzer

Descriptive Soil Classification

Soil classification as noted on the soil boring logs is based Unified Soil Classification System. Where sufficient laboratory data exist to classify the soils consistent with ASTM D2487 "Classification of Soils for Engineering Purposes" this procedure is used. ASTM D2488 "Description and Identification of Soils (Visual-Manual Procedure)" is also used to classify the soils, particularly where insufficient laboratory data exist to classify the soils in accordance with ASTM D2487. In addition to USCS classification, coarse grained soils are classified on the basis of their in-place relative density, and fine-grained soils are classified on the basis of their consistency. See "Strength Terms" table below for details. The ASTM standards noted above are for reference to methodology in general. In some cases, variations to methods are applied as a result of local practice or professional judgment.

Location And Elevation Notes

Exploration point locations as shown on the Exploration Plan and as noted on the soil boring logs in the form of Latitude and Longitude are approximate. See Exploration and Testing Procedures in the report for the methods used to locate the exploration points for this project. Surface elevation data annotated with +/- indicates that no actual topographical survey was conducted to confirm the surface elevation. Instead, the surface elevation was approximately determined from topographic maps of the area.

Strength Terms

Relative Density of Coarse-Grained Soils (More than 50% retained on No. 200 sieve.) Density determined by Standard Penetration Resistance			Consistency of Fine-Grained Soils (50% or more passing the No. 200 sieve.) Consistency determined by laboratory shear strength testing, field visual-manual procedures or standard penetration resistance			
Relative Density	Standard Penetration or N-Value (Blows/Ft.)	Ring Sampler (Blows/Ft.)	Consistency	Unconfined Compressive Strength Qu (psf)	Standard Penetration or N-Value (Blows/Ft.)	Ring Sampler (Blows/Ft.)
Very Loose	0 - 3	0 - 5	Very Soft	less than 500	0 - 1	< 3
Loose	4 - 9	6 - 14	Soft	500 to 1,000	2 - 4	3 - 5
Medium Dense	10 - 29	15 - 46	Medium Stiff	1,000 to 2,000	4 - 8	6 - 10
Dense	30 - 50	47 - 79	Stiff	2,000 to 4,000	8 - 15	11 - 18
Very Dense	> 50	≥ 80	Very Stiff	4,000 to 8,000	15 - 30	19 - 36
			Hard	> 8,000	> 30	> 37

Relevance of Exploration and Laboratory Test Results

Exploration/field results and/or laboratory test data contained within this document are intended for application to the project as described in this document. Use of such exploration/field results and/or laboratory test data should not be used independently of this document.

Unified Soil Classification System

Criteria for Assigning Group Symbols and Group Names Using Laboratory Tests ^A				Soil Classification		
				Group Symbol	Group Name ^B	
Coarse-Grained Soils: More than 50% retained on No. 200 sieve	Gravels: More than 50% of coarse fraction retained on No. 4 sieve	Clean Gravels: Less than 5% fines ^C	$Cu \geq 4$ and $1 \leq Cc \leq 3$ ^E	GW	Well-graded gravel ^F	
		Gravels with Fines: More than 12% fines ^C	$Cu < 4$ and/or $[Cc < 1 \text{ or } Cc > 3.0]$ ^E	GP	Poorly graded gravel ^F	
			Fines classify as ML or MH	GM	Silty gravel ^{F, G, H}	
		Sands: 50% or more of coarse fraction passes No. 4 sieve	Clean Sands: Less than 5% fines ^D	Fines classify as CL or CH	GC	Clayey gravel ^{F, G, H}
	$Cu \geq 6$ and $1 \leq Cc \leq 3$ ^E			SW	Well-graded sand ^I	
	Sands with Fines: More than 12% fines ^D	Sands with Fines: More than 12% fines ^D	$Cu < 6$ and/or $[Cc < 1 \text{ or } Cc > 3.0]$ ^E	SP	Poorly graded sand ^I	
			Fines classify as ML or MH	SM	Silty sand ^{G, H, I}	
	Fine-Grained Soils: 50% or more passes the No. 200 sieve	Silts and Clays: Liquid limit less than 50	Inorganic:	PI > 7 and plots above "A" line ^J	CL	Lean clay ^{K, L, M}
				PI < 4 or plots below "A" line ^J	ML	Silt ^{K, L, M}
			Organic:	$\frac{LL \text{ oven dried}}{LL \text{ not dried}} < 0.75$	OL	Organic clay ^{K, L, M, N} Organic silt ^{K, L, M, O}
Inorganic:				PI plots on or above "A" line	CH	Fat clay ^{K, L, M}
		PI plots below "A" line	MH	Elastic silt ^{K, L, M}		
Silts and Clays: Liquid limit 50 or more		Organic:	$\frac{LL \text{ oven dried}}{LL \text{ not dried}} < 0.75$	OH	Organic clay ^{K, L, M, P} Organic silt ^{K, L, M, Q}	
			Highly organic soils:	Primarily organic matter, dark in color, and organic odor	PT	Peat

- ^A Based on the material passing the 3-inch (75-mm) sieve.
- ^B If field sample contained cobbles or boulders, or both, add "with cobbles or boulders, or both" to group name.
- ^C Gravels with 5 to 12% fines require dual symbols: GW-GM well-graded gravel with silt, GW-GC well-graded gravel with clay, GP-GM poorly graded gravel with silt, GP-GC poorly graded gravel with clay.
- ^D Sands with 5 to 12% fines require dual symbols: SW-SM well-graded sand with silt, SW-SC well-graded sand with clay, SP-SM poorly graded sand with silt, SP-SC poorly graded sand with clay.
- ^E $Cu = D_{60}/D_{10}$ $Cc = \frac{(D_{30})^2}{D_{10} \times D_{60}}$
- ^F If soil contains $\geq 15\%$ sand, add "with sand" to group name.
- ^G If fines classify as CL-ML, use dual symbol GC-GM, or SC-SM.
- ^H If fines are organic, add "with organic fines" to group name.
- ^I If soil contains $\geq 15\%$ gravel, add "with gravel" to group name.
- ^J If Atterberg limits plot in shaded area, soil is a CL-ML, silty clay.
- ^K If soil contains 15 to 29% plus No. 200, add "with sand" or "with gravel," whichever is predominant.
- ^L If soil contains $\geq 30\%$ plus No. 200 predominantly sand, add "sandy" to group name.
- ^M If soil contains $\geq 30\%$ plus No. 200, predominantly gravel, add "gravelly" to group name.
- ^N PI ≥ 4 and plots on or above "A" line.
- ^O PI < 4 or plots below "A" line.
- ^P PI plots on or above "A" line.
- ^Q PI plots below "A" line.

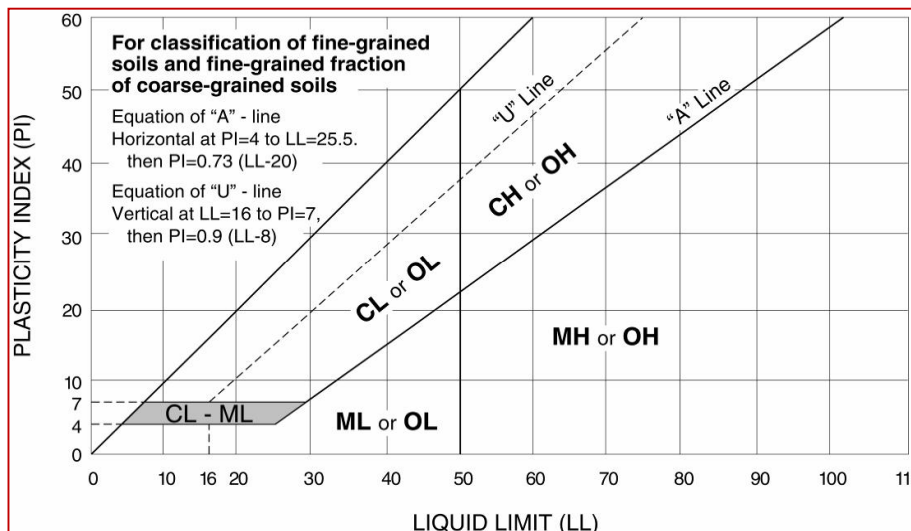

Design/System/Construction/Assembly Usage Disclaimer

- Authorities Having Jurisdiction should be consulted in all cases as to the particular requirements covering the installation and use of UL Certified products, equipment, system, devices, and materials.
- Authorities Having Jurisdiction should be consulted before construction.
- Fire resistance assemblies and products are developed by the design submitter and have been investigated by UL for compliance with applicable requirements. The published information cannot always address every construction nuance encountered in the field.
- When field issues arise, it is recommended the first contact for assistance be the technical service staff provided by the product manufacturer noted for the design. Users of fire resistance assemblies are advised to consult the general Guide Information for each product category and each group of assemblies. The Guide Information includes specifics concerning alternate materials and alternate methods of construction.
- Only products which bear UL's Mark are considered Certified.

BXUV - Fire Resistance Ratings - ANSI/UL 263 Certified for United States

BXUV7 - Fire Resistance Ratings - CAN/ULC-S101 Certified for Canada

[See General Information for Fire-resistance Ratings - ANSI/UL 263 Certified for United States](#)

[Design Criteria and Allowable Variances](#)

[See General Information for Fire Resistance Ratings - CAN/ULC-S101 Certified for Canada](#)

[Design Criteria and Allowable Variances](#)

Design No. L501

September 24, 2024

Unrestrained Assembly Rating — 1 Hr.

Finish Rating — (See Items 5 and 5A)

This design was evaluated using a load design method other than the Limit States Design Method (e.g., Working Stress Design Method). For jurisdictions employing the Limit States Design Method, such as Canada, a load restriction factor shall be used — See Guide [BXUV](#) or [BXUV7](#)

*** Indicates such products shall bear the UL or cUL Certification Mark for jurisdictions employing the UL or cUL Certification (such as Canada), respectively.**

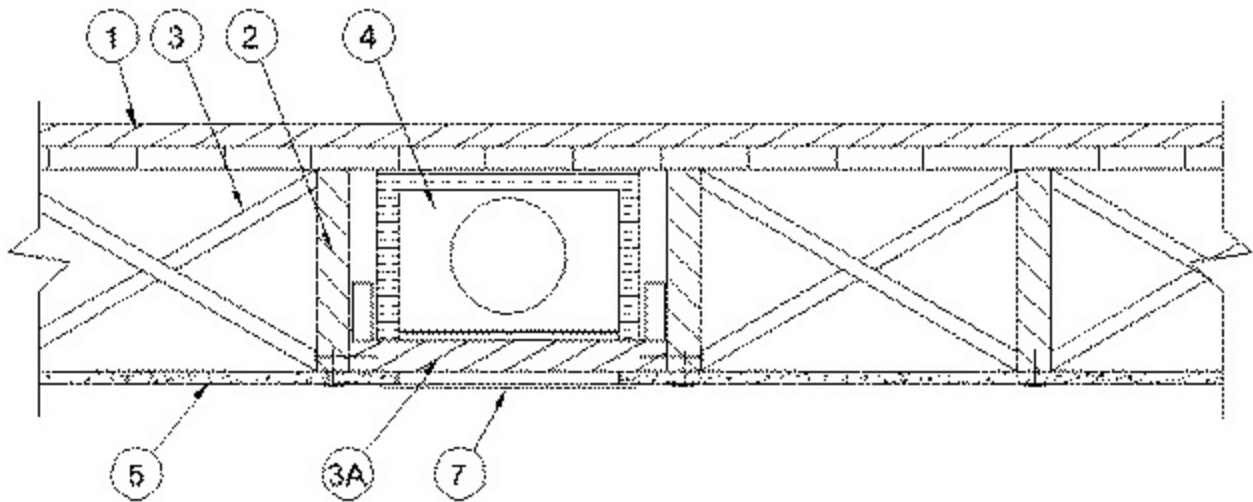

1. **Flooring Systems** — The flooring system shall consist of one of the following:

System No. 1

Subflooring — Min 1 by 6 in. T & G lumber fastened diagonally to joists, or min 15/32 in. thick plywood or min 7/16 in. thick oriented strand board (OSB) wood structural panels, min grade "C-D" or "Sheathing". Face grain of plywood or strength axis of panel to be perpendicular to joists with joints staggered. Panels secured to joists with construction adhesive and No. 6d ringed shank nails spaced 12 in. OC along each joist. Staples having equal or greater withdrawal and lateral resistance strength may be substituted for the 6d nails.

Vapor Barrier — Nom 0.010 in. thick commercial rosin-sized building paper.

Finish Flooring — Min 1 by 4 in. T & G lumber installed perpendicular to joists, or min 19/32 in. thick wood structural panels, min grade "Underlayment" or "Single-Floor". Face grain of plywood or strength axis of panels to be perpendicular to joists with joints staggered.

System No. 2

Subflooring — Min 15/32 in. thick wood structural panels, min grade "C-D" or "Sheathing". Face grain of plywood or strength axis of panels to be perpendicular to the joists with joints staggered, secured as described in System No. 1

Vapor Barrier — (Optional) — Nom 0.030 in. thick commercial asphalt saturated felt.

Floor Mat Materials* — (Optional) — Floor mat material loose laid over the subfloor. Refer to manufacturer's instructions regarding the minimum thickness of floor topping over each floor mat material.

UNITED STATES GYPSUM CO — Types SAM, LEVELROCK® Brand Sound Reduction Board, LEVELROCK® Brand Floor Underlayment SRM-25

Alternate Floor Mat Materials* — (Optional) — Floor mat material loose laid over the subfloor. Refer to manufacturer's instructions regarding minimum thickness of floor topping over floor mat.

GRASSWORX L L C — SC Types

Finish Flooring — **Floor Topping Mixture*** — Min 3/4 having a min compressive strength of 1800 psi. Refer to manufacturer's instructions accompanying the material for specific mix design.

UNITED STATES GYPSUM CO — Type C, SD, LRK, HSLRK

LATICRETE SUPERCAP L L C — Types LRK, HSLRK

USG MEXICO S A D E C V — Types LRK, HSLRK, CSD

System No. 3

Subflooring — Min 19/32 in. thick wood structural panels, min grade "C-D" or "Sheathing". Face grain of plywood or strength axis of panel to be perpendicular to joists with joints staggered, secured as described in System No. 1.

Floor Mat Materials* — (Optional) — Floor mat material nom 5/64 in. (2 mm) thick adhered to subfloor with Hacker Floor Primer. Primer to be applied to the surface of the mat prior to the placement of floor-topping mixture. Floor topping thickness a min 1 in. over the floor mat.

HACKER INDUSTRIES INC — Type Hacker Sound-Mat

Alternate Floor Mat Materials — (Optional) — Floor mat material nom 1/4 in. (6 mm) thick adhered to subfloor with Hacker Floor Primer. Primer to be applied to the surface of the mat prior to the placement of a min 1-1/4 in. (32 mm) of floor-topping mixture.

HACKER INDUSTRIES INC — Type Hacker Sound-Mat II

Alternate Floor Mat Materials — (Optional) — Floor mat material nom 1/8 in. (3 mm) thick loose laid over the subfloor. Floor topping thickness shall be a min of 3/4 in. (19 mm).

HACKER INDUSTRIES INC — FIRM-FILL SCM 125

Alternate Floor Mat Materials — (Optional) — Floor mat material nom 1/4 in. (6 mm) thick loose laid over the subfloor. Floor topping thickness shall be a min of 1 in. (25 mm).

HACKER INDUSTRIES INC — Type FIRM-FILL SCM 250, Quiet Qurl 55/025

Alternate Floor Mat Materials — (Optional) — Floor mat material nom 3/8 in. (10 mm) thick loose laid over the subfloor. Floor topping thickness shall be a min of 1-1/4 in. (32 mm)

HACKER INDUSTRIES INC — FIRM-FILL SCM 400, Quiet Qurl 60/040

Alternate Floor Mat Materials — (Optional) — Floor mat material nom 3/4 in. (19 mm) thick loose laid over the subfloor. Floor topping thickness shall be a min of 1-1/2 in. (38 mm).

HACKER INDUSTRIES INC — Type FIRM-FILL SCM 750, Quiet Qurl 65/075

Metal Lath (Optional) — For use with 3/8 in. (10 mm) floor mat materials, 3/8 in. expanded steel diamond mesh, 3.4 lbs/sq yd placed over the floor mat material. Hacker Floor Primer to be applied prior to the placement of the metal lath. When metal lath is used, floor topping thickness a nom 1-1/4 in. over the floor mat.

Finish Flooring — Floor Topping Mixture* — Min 3/4 in. thickness of floor topping mixture having a min compressive strength of 1100 psi. Mixture shall consist of 6.8 gal of water to 80 lbs of floor topping mixture to 1.9 cu ft of sand.

HACKER INDUSTRIES INC — Firm-Fill Gypsum Concrete, Firm-Fill 2010, Firm-Fill 3310, Firm-Fill 4010, Firm-Fill High Strength, Gyp-Span Radiant

System No. 4

Subflooring — Min 15/32 in. thick wood structural panels, min grade "C-D" or "Sheathing". Face grain of plywood or strength axis of panel to be perpendicular to joists with joints staggered, secured as described in System No. 1.

Vapor Barrier — (Optional) — Nom 0.030 in thick commercial asphalt saturated felt.

Finish Flooring — Floor Topping Mixture* — Min 1-1/2 in. thickness of floor topping mixture having a min compressive strength of 1000 psi and a cast density of 100 plus or minus 5 pcf. Foam concentrate mixed 40:1 by volume with water and expanded at 100 psi through nozzle. Mixture shall consist of 1.4 cu feet of preformed foam concentrate to 94 lbs Type I Portland cement, 300 lbs of sand with 5-1/2 gal of water.

ELASTIZELL CORP OF AMERICA — Type FF

System No. 5

Subflooring — Min 15/32 in. thick wood structural panels, min grade "C-D" or "Sheathing". Face grain of plywood or strength axis of panel to be perpendicular to joists with joints staggered, secured as described in System No. 1.

Vapor Barrier — (Optional) — Nom 0.030 in thick commercial asphalt saturated felt.

Finish Flooring — Floor Topping Mixture* — Min 1-1/2 in. thickness of floor topping mixture having a min compressive strength of 1000 psi and a cast density of 100 plus or minus 5 pcf. Foam concentrate mixed 40:1 by volume with water and expanded at 100 psi through nozzle. Mixture shall consist of 1.2 cu feet of preformed foam concentrate to 94 lbs Type I Portland cement, 300 lbs of sand with 5-1/2 gal of water.

AERIX INDUSTRIES — Floor Topping Mixture

System No. 6

Deleted.

System No. 7

Subflooring — Min 15/32 in. thick wood structural panels, min grade "C-D" or "Sheathing". Face grain of plywood or strength axis of panel to be perpendicular to joists with joints staggered, secured as described in System No. 1.

Finish Flooring — Floor Topping Mixture* — Min 3/4 or 1 in. thickness of floor topping mixture for 19/32 or 15/32 in. thick wood structural panels respectively, having a min compressive strength of 1000 psi. Mixture shall consist of 5 to 8 gal of water to 80 lbs of floor topping mixture to 2.1 cu ft of sand.

ULTRA QUIET FLOORS — UQF-A, UQF-Super Blend, UQF-Plus 200

System No. 8

Subflooring — Min 15/32 in. wood structural panels, min grade "C-D" or "Sheathing". Face grain of plywood or strength axis of panels to be perpendicular to joists with joints staggered, secured as described in System No. 1.

Vapor Barrier — (Optional) — Nom 0.030 in thick commercial asphalt saturated felt.

Finish Flooring — Floor Topping Mixture* — Min 3/4 in. thickness of floor topping mixture having a minimum compressive strength of 1500 psi. Refer to manufacturer's instructions accompanying the material for specific mix design.

MAXXON CORP — Type Maxxon Standard and Maxxon High Strength

Floor Mat Materials* — (Optional) — Floor mat material loose laid over the subfloor. Refer to manufacturer's instructions regarding the minimum thickness of floor topping over each floor mat material.

MAXXON CORP — Type Encapsulated Sound Mat.

Floor Mat Reinforcement — (Optional) - Refer to manufacturer's instructions regarding minimum thickness of floor topping for use with floor mat reinforcement.

Metal Lath — (Optional) — 3/8 in. expanded galvanized steel diamond mesh, 3.4 lbs/sq yd loose laid over the floor mat material.

Fiber Glass Reinforcement - (Optional, Not Shown) - 0.015 in. thick PVC coated non-woven fiberglass mesh, 0.368 lbs/sq yd loose laid over the floor mat material.

System No. 9

Subflooring — Min 1 by 6 in. T & G lumber fastened diagonally to joists, or min 15/32 in. thick plywood or min 7/16 in. thick oriented strand board (OSB) wood structural panels, min grade "C-D" or "Sheathing". Face grain of plywood or strength axis of panels to be perpendicular to the joists with joints staggered, secured as described in System No. 1.

Finish Floor — Mineral and Fiber Board* — Min 1/2 in. thick, supplied in sizes ranging from 3 ft by 4 ft to 8 ft by 12 ft. All joints to be staggered a min of 12 in. with adjacent sub-floor joints.

HOMASOTE CO — Type 440-32 Mineral and Fiber Board

System No. 10

Subflooring — Min 15/32 in. thick wood structural panels, min grade "C-D" or "Sheathing". Face grain of plywood or strength axis of panels to be perpendicular to the joists with joints staggered, secured as described in System No. 1.

Vapor Barrier — (Optional) — Nom 0.030 in. thick commercial asphalt saturated felt.

Finish Flooring — Floor Topping Mixture* — Min 3/4 or 1 in. thickness of floor topping mixture for 19/32 or 15/32 in. thick wood structural panels respectively, having a min compressive strength of 1000 psi. Refer to manufacturer's instructions accompanying the material for specific mix design.

ARCOSA SPECIALTY MATERIALS — AccuCrete® Types NexGen, Green, Prime and PrePour, AccuRadiant®, AccuLevel® Types G40, G50 and SD30

Alternate Floor Mat Material* — (Optional) - Floor mat material nominal 2 - 9.5 mm thick loose laid over the subfloor. Floor topping shall be a min of 3/4 in. or 1 in. thick for 19/32 or 15/32 in. thick wood structural panels respectively.

ARCOSA SPECIALTY MATERIALS — AccuQuiet® D13, D-18, D25, DX38, EM.125, EM.125S, EM.250, EM.250S, EM.375, EM.375S, EM.750, and EM.750S.

System No. 11

Subflooring — Min 15/32 in. thick wood structural panels, min grade "C-D" or "Sheathing". Face grain of plywood or strength axis of panels to be perpendicular to the joists with joints staggered, secured as described in System No. 1.

Vapor Barrier — (Optional) — Nom 0.030 in. thick commercial asphalt saturated felt.

Finish Flooring — Floor Topping Mixture* — Min 3/4 in. thickness of floor topping mixture having a minimum compressive strength of 1500 psi. Refer to manufacturer's instructions accompanying the material for specific mix design.

FORMULATED MATERIALS LLC — Types FR-25, FR-30, SiteMix, and Treadstone Advantage

Alternate Floor Mat Material* — (Optional) — Floor mat material nominal 2 - 9.5 mm thick loose laid over the subfloor. Floor topping thickness shall be a minimum of 3/4 in.

FORMULATED MATERIALS LLC — Types M1, M2, M3, Elite, Duo, R1, and R2.

System No. 12

Deleted.

System No. 13

Subflooring — Min 15/32 in. thick wood structural panels, min grade "C-D" or "Sheathing". Face grain of plywood or strength axis of panels to be perpendicular to the joists with joints staggered, secured as described in System No. 1.

Vapor Barrier — (Optional) — Commercial asphalt saturated felt, 0.030 in. thick.

Vapor Barrier — (Optional) — Nom 0.010 in. thick commercial rosin-sized building paper.

Finish Flooring* — Min 3/4 in. thickness of any Floor Topping Mixture bearing the UL Classification Marking as to Fire Resistance. See Floor- and Roof-Topping Mixtures (CCOX) category for names of Classified Companies. Refer to the manufacturer's instructions accompanying the material and/or contact the manufacturer's technical support for specific mix design and minimum thickness recommended for use with eligible floor mat(s).

Floor Mat Materials* — (Optional) — Nom. 1/4 in. thick loose laid over the subfloor. Floor topping thickness shall be a minimum of 3/4 in.

KEENE BUILDING PRODUCTS CO INC — Type Quiet Qurl 55/025 and Quiet Qurl 55/025 N

Alternate Floor Mat Materials* — (Optional) — Floor mat material Nom. 3/8 in. thick loose laid over the subfloor. Floor topping thickness shall be a minimum of 1 in.

KEENE BUILDING PRODUCTS CO INC — Type Quiet Qurl 60/040 and Quiet Qurl 60/040 N

Alternate Floor Mat Materials* — (Optional) — Floor mat material Nom. 3/4 in. thick loose laid over the subfloor. Floor topping thickness shall be a minimum of 1-1/2 in.

KEENE BUILDING PRODUCTS CO INC — Type Quiet Qurl 65/075, Quiet Qurl 65/075 N

Alternate Floor Mat Materials* — (Optional) — Floor mat material Nom. 1/8 in. thick loose laid over the subfloor. Floor topping thickness shall be a minimum of 3/4 in.

KEENE BUILDING PRODUCTS CO INC — Type Quiet Qurl 52/013 and Quiet Qurl 52/013 N

Alternate Floor Mat Materials* — (Optional) — Floor mat material Nom. 1/4 in. entangled net core with a compressible fabric attached to the bottom loose laid over the subfloor. Floor topping thickness shall be a minimum of 1 in.

KEENE BUILDING PRODUCTS CO INC — Quiet Qurl 55/025 MT and Quiet Qurl 55/025 N MT

System No. 14

Subflooring — Min 23/32 in. thick T&G wood structural panels, min grade "Underlayment" or "Single-Floor". Face grain of plywood or strength axis of panels to be perpendicular to the joists with end joints staggered, secured as described in System No. 1.

Gypsum Board* — One layer of nom 5/8 in. thick, 4 ft wide gypsum board, installed with long dimension perpendicular to joists. Gypsum board secured with 1 in. long No. 6 Type W bugle head steel screws spaced 12 in. OC and located a min of 1-1/2 in. from side and end joints. The joints of the gypsum board are to be staggered a minimum of 12 inches from the joints of the subfloor.

GEORGIA-PACIFIC GYPSUM L L C — Type DS

Floor Mat Materials* — (As an alternate to the single layer gypsum board) — Floor mat material loose laid over the subfloor.

MAXXON CORP — Type Encapsulated Sound Mat.

Gypsum Board* — (For use when floor mat is used) Two layers of nom 5/8 in. thick, 4 ft wide gypsum board, installed with long dimension perpendicular to joists on top of the floor mat material. Gypsum board secured to each other with 1 in. long No. 6 Type G bugle head steel screws spaced 12 in. OC and located a min of 1-1/2 in. from side and end joints. The joints of the gypsum board are to be staggered a minimum of 12 inches in between layers and from the joints of the subfloor.

GEORGIA-PACIFIC GYPSUM L L C — Type DS**System No. 15**

Subflooring — Min 15/32 in. thick wood structural panels, min grade "C-D" or "Sheathing". Face grain of plywood or strength axis of panels to be perpendicular to the joists with joints staggered, secured as described in System No. 1.

Finish Flooring — Floor Topping Mixture* — Min 3/4 in. thickness of floor topping mixture for min 15/32 in. thick wood structural panels, having a min compressive strength of 2150 psi. Refer to manufacturer's instructions accompanying the material for specific mix design.

MAPEI CORP — Type Planitex SL 35

System No. 16

Subflooring — Min. 15/32 in. thick wood structural panels, min. grade "C-D" or "Sheathing". Face grain of plywood or strength axis of panels to be perpendicular to joists with joints staggered, secured as described in System No. 1.

Vapor Barrier — (Optional) — Nom 0.030 in. thick commercial asphalt saturated felt.

Finish Flooring — Floor Topping Mixture* — Min 3/4 in. thickness of floor topping mixture for 15/32 in. thick wood structural panels respectively, having a min compressive strength of 2100 psi. Refer to manufacturer's instructions accompanying the material for specific mix design.

THE STRONG CO INC — Type UltraLevel

System No. 17

Subflooring — Min 15/32 in. thick wood structural panels, min grade "C-D" or "Sheathing". Face grain of plywood or strength axis of panels to be perpendicular to the joists with joints staggered, secured as described in System No. 1.

Vapor Barrier — (Optional) — Nom 0.030 in. thick commercial asphalt saturated felt.

Finish Flooring — Floor Topping Mixture* — Min 3/4 or 1 in. thickness of floor topping mixture for 19/32 or 15/32 in. thick wood structural panels respectively, having a min compressive strength of 1000 psi. Refer to manufacturer's instructions accompanying the material for specific mix design.

DEPENDABLE LLC — GSL M3.4, GSL K2.6, GSL-CSD and GSL RH

Floor Mat Materials* — (Optional) — Nom. 1/4 in. thick loose laid over the subfloor. Floor topping thickness shall be a minimum of 3/4 in.

KEENE BUILDING PRODUCTS CO INC — Type Quiet Qurl 55/025 and Quiet Qurl 55/025 N

Alternate Floor Mat Materials* — (Optional) — Floor mat material Nom. 3/8 in. thick loose laid over the subfloor. Floor topping thickness shall be a minimum of 1 in.

KEENE BUILDING PRODUCTS CO INC — Type Quiet Qurl 60/040 and Quiet Qurl 60/040 N

Alternate Floor Mat Materials* — (Optional) — Floor mat material Nom. 3/4 in. thick loose laid over the subfloor. Floor topping thickness shall be a minimum of 1-1/2 in.

KEENE BUILDING PRODUCTS CO INC — Type Quiet Qurl 65/075, Quiet Qurl 65/075 N

Alternate Floor Mat Materials* — (Optional) — Floor mat material Nom. 1/8 in. thick loose laid over the subfloor. Floor topping thickness shall be a minimum of 3/4 in.

KEENE BUILDING PRODUCTS CO INC — Type Quiet Qurl 52/013 and Quiet Qurl 52/013 N

Alternate Floor Mat Materials* — (Optional) — Floor mat material Nom. 1/4 in. entangled net core with a compressible fabric attached to the bottom loose laid over the subfloor. Floor topping thickness shall be a minimum of 1 in.

KEENE BUILDING PRODUCTS CO INC — Quiet Qurl 55/025 MT and Quiet Qurl 55/025 N MT

System No. 18

Subflooring — Building Units* — Nom 3/4 in. thick, tongue and grooved boards. Long dimension of boards to be perpendicular to joists with end joints staggered a min of 4 ft. and centered over the joists. Boards secured to joists with 2 in. long self-drilling, self-tapping screws or 2 in. x 0.113 in. Ring Shank nails spaced a max of 12 in. OC in the field with screws/nails located 1 in. from long edge, and max 8 in. OC along the end joints with screws/nails located 1/2 in. from end joint.

ECTEK INTERNATIONAL INC — Type MegaBoard

Vapor Barrier — Nom 0.010 in. thick commercial rosin-sized building paper.

Finish Flooring — Min 1 by 4 in. T & G lumber installed perpendicular to joists, or min 19/32 in. thick wood structural panels, min grade "Underlayment" or "Single-Floor". Face grain of plywood or strength axis of panels to be perpendicular to joists with joints staggered

System No. 19

Subflooring — Min 1 by 6 in. T & G lumber fastened diagonally to joists, or min 15/32 in. thick plywood or min 7/16 in. thick oriented strand board (OSB) wood structural panels, min grade "C-D" or "Sheathing". Face grain of plywood or strength axis of panel to be perpendicular to joists with joints staggered, secured as described in System No. 1.

Finish Flooring* — Floor Topping Materials — Min 3/4 in. to 1-1/2 in. thickness of any Floor Topping Mixture bearing the UL Classification Marking as to Fire Resistance with a minimum compressive strength of 1500 psi.

See **Floor- and Roof-Topping Mixtures** (CCOX) category for names of Classified Companies. Refer to the manufacturer's instructions accompanying the material and/or contact the manufacturer's technical support for specific mix design and minimum thickness recommended for use with eligible floor mat(s).

Floor Mat Materials* — (Optional) — Floor mat material nom 1/8 in. to 3/4 in. thick. Loose laid over the subfloor. When used, Acousti-flor CSM (Crack Suppression Mat) is loose laid over the floor mat material. Floor topping material thickness is dependent on thickness of floor mat used.

WALFLOR INDUSTRIES INC — Type Acousti-flor, Acousti-flor CSM. Floor topping thickness depends on products used as follows:

Acousti-flor (1/8 in. thick) - Floor topping thickness shall be a minimum of 3/4 in.

Acousti-flor (1/4 in. thick) - Floor topping thickness shall be a minimum of 1 in.

Acousti-flor (3/8 in. thick) - Floor topping thickness shall be a minimum of 1 in.

Acousti-flor (3/4 in. thick) - Floor topping thickness shall be a minimum of 1-1/2 in.

Metal Lath — (Optional) — Expanded steel diamond mesh, 2.5 lb / sq yd loose laid over floor mat material.

Fiberglass Mesh Reinforcement — (Optional) — Coated non-woven glass fiber mesh grid loose laid over floor mat material.

System No. 20

Subflooring — Min 1 by 6 in. T & G lumber fastened diagonally to joists, or min 15/32 in. thick plywood or min 7/16 in. thick oriented strand board (OSB) wood structural panels, min grade "C-D" or "Sheathing". Face grain of plywood or strength axis of panel to be perpendicular to joists with joints staggered, secured as described in System No. 1.

Finish Flooring - Floor Topping Mixture* — Min 1 in. thickness of floor topping mixture having a min compressive strength of 4500 psi. Refer to manufacturer's instructions accompanying the material for specific mix design.

SIKA DEUTSCHLAND GMBH — Type SCHONOX AP Rapid Plus

System No. 21

Subflooring - Building Units* — Nom. 1-1/2 in. thick T & G laminated composite plywood sub-floor panels to be perpendicular to the trusses with end joints staggered 4 ft. End joints centered over top chord of trusses. Subfloor panels secured to trusses with construction adhesive and #8 by 3 in. wood screws spaced 12 in. OC in the field and 6 in. OC at the end joints.

RSP INDUSTRIES INC — SAP board

System No. 22

Subflooring — Min 1 by 6 in. T & G lumber fastened diagonally to joists, or min 15/32 in. thick plywood or min 7/16 in. thick oriented strand board (OSB) wood structural panels, min grade "C-D" or "Sheathing". Face grain of plywood or strength axis of panel to be perpendicular to joists with joints staggered, secured as described in System No. 1.

Vapor Barrier — (Optional) - Commercial asphalt saturated felt, 0.030 in. thick.

Vapor Barrier — (Optional) - Nom 0.010 in. thick commercial rosin-sized building paper.

Finish Flooring - Floor Topping Mixture* — Min 3/4 in. thickness of any Floor Topping Mixture bearing the UL Classification Marking as to Fire Resistance. See Floor- and Roof-Topping Mixtures (CCOX) category for names of Classified Companies. Refer to the manufacturer's instructions accompanying the material and/or contact the manufacturer's technical support for specific mix design and minimum thickness recommended for use with eligible floor mat(s).

Floor Mat Materials* — (Optional, Not Shown) - Floor mat material loose laid over the subfloor. Refer to manufacturer's instructions regarding the minimum thickness of floor topping over each floor mat material.

Freudenberg Performance Materials LP — EnkaSonic® by Collbond a member of the Low & Bonar group Types 125, 250, 250 Plus, 400, 400 Plus, 750, and 750 Plus.

Floor Mat Reinforcement — (Optional) - Refer to manufacturer's instructions regarding minimum thickness of floor topping for use with floor mat reinforcement.

Metal Lath — (Optional) — Expanded steel diamond mesh, 2.5 lb / sq yd loose laid over floor mat material.

Fiberglass Mesh Reinforcement — (Optional) — Coated non-woven glass fiber mesh grid loose laid over floor mat material.

System No. 23

Subflooring — Subflooring — Min 23/32 in. thick T&G wood structural panels, min grade "Underlayment" or "Single-Floor". Face grain of plywood or strength axis of panels to be perpendicular to the joists with end joints staggered secured as described in System No. 1.

Finish Floor - Building Units* — Min 1/2 in. thick magnesium oxide panels installed parallel, perpendicular, or diagonally to trusses with panel edges offset a min of 4 in. between subfloor and magnesium oxide panels. Panels secured to subfloor with construction adhesive and corrosion resistant fasteners, spaced 12 in. OC around the perimeter and in the field of the panel. Fasteners must be placed no closer than 1/2 in. from all panel edges and no closer than 2 in. from panel corners.

HUBER ENGINEERED WOODS L L C — Type 1/2 in. Square Edge Exacor™ Board

System No. 24

Subflooring — Min 15/32 in. thick wood structural panels, min grade "C-D" or "Sheathing". Face grain of plywood or strength axis of panels to be perpendicular to the joists with joints staggered.

Vapor Barrier — (Optional) — Nom 0.030 in. thick commercial asphalt saturated felt.

Floor Mat Materials* — (Optional) — Floor mat material loose laid over the subfloor. Refer to manufacturer's instructions regarding the minimum thickness of floor topping over each floor mat material.

GRASSWORX L L C — SC Types

Finish Flooring* — Min 3/4 in. thickness of any Floor Topping Mixture bearing the UL Classification Marking as to Fire Resistance. See Floor- and Roof-Topping Mixtures (CCOX) category for names of Classified Companies. Refer to the manufacturer's instructions accompanying the material and/or contact the manufacturer's technical support for specific mix design and minimum thickness recommended for use with eligible floor mat(s).

System No. 25

Subflooring - Building Units* — Nom. 1-3/16 in. thick T & G laminated composite plywood sub-floor panels to be perpendicular to the joist with end joints staggered 4 ft. End joints centered over top chord of joist. Subfloor panels secured to joist with construction adhesive and #8 by 2-3/8 in. wood screws spaced 12 in. OC in the field and 6 in. OC at the end joints.

RSP INDUSTRIES INC — SAP 1.0

System No. 26

Subflooring — Min 1 by 6 in. T & G lumber fastened diagonally to joists, or min 15/32 in. thick plywood or min 7/16 in. thick oriented strand board (OSB) wood structural panels, min grade "C-D" or "Sheathing". Face grain of plywood or strength axis of panel to be perpendicular to joists with joints staggered, secured as described in System No. 1.

Finish Flooring - Floor Topping Mixture* — Min 3/4 in. thickness of floor topping mixture having a min compressive strength of 1000 psi. Refer to manufacturer's instructions accompanying the material for specific mix design.

ALPHAGYP, LLC — Type AG3000

2. **Wood Joists** — Min 2 by 10, spaced 16 in. OC and effectively fireblocked in accordance with local codes.

3. **Cross Bridging** — Min 1 by 3 in. or min 2 by 10 solid blocking.

3A. **Horizontal Bridging** — Used in lieu of Item 3 in same joist bay as ceiling damper (Item 4), when ceiling damper is employed. Wood 2 by 4 in. secured between joists with nails.

4. **Ceiling Damper*** — (Optional) — Max nom area shall be 198 sq in. Max rectangular size shall be 12 in. wide by 16-1/2 in. long. Max height of damper shall be 9-3/8 in. Aggregate damper openings shall not exceed 99 sq in. per 100 sq ft of ceiling area. Damper installed in accordance with the manufacturers installation instructions provided with the damper. A steel grille (Item 7) shall be installed in accordance with installation instructions.

AIR BALANCE INC — Type 299 (See Item 5A)

AIR KING VENTILATION PRODUCTS — Series FRAS, Series FRAK, Series FRAKV

CENTRAL VENTILATION SYSTEMS CO L L C — Models C-S/R-HC(-A), C-RD-HC(-A)

JAMIL ALI NASSER AL-ZADJALI FOR INDUSTRY — Models C-S/R-HC(-A), C-RD-HC(-A)

BADR & ASFOUR COMPANY FOR ENGINEERING AND METAL INDUSTRIES — Models C-S/R-HC(-A), C-RD-HC(-A)

GREENHECK FAN CORP — Model CRD-1WJ

METAL-FAB INC — Models MSCDHC, MRCDHC

BRISK MFG INC — Model BMI-50-CRD-S/R-WT

PRICE INDUSTRIES LTD — Models CD-S/R-HC, CD-RD-HC

RUSKIN COMPANY — Model CFD7

UNITED ENERTECH CORP — Models C-S/R-HC(-A), C-RD-HC(-A)

5. **Gypsum Board*** — — Nom 5/8 in. thick, 48 in. wide gypsum board, installed with long dimension perpendicular to joists. Gypsum board secured with 1-7/8 in. long, 6d cement coated nails spaced 6 in. OC.

AMERICAN GYPSUM CO — Types AGX-1, AG-C, LightRoc

BEIJING NEW BUILDING MATERIALS PUBLIC LTD CO — Type DBX-1

CABOT MANUFACTURING ULC — Type X, 5/8 Type X, Type Blueglass Exterior Sheathing

CERTAINTED GYPSUM INC — Type C, Type X-1, Types LGFC6A, LGFC-C/A, LWTX

CGC INC — Types C, IP-X1, IP-X2, IPC-AR, SCX, WRX

GEORGIA-PACIFIC GYPSUM L L C — Types 5, 9, C, GPFS1, GPFS6, DA, DAP, DAPC, DGG, DS, Type X, Veneer Plaster Base-Type X, Water Rated-Type X, Sheathing Type-X, Soffit-Type X, TG-C, GreenGlass Type X, Type LWX (finish rating 22 min), Veneer Plaster Base-Type LWX (finish rating 22 min), Water Rated-Type LWX (finish rating 22 min), Sheathing Type-LWX (finish rating 22 min), Soffit-Type LWX (finish rating 22 min), Type LWX (finish rating 22 min), Type LW2X (finish rating 20 min), Veneer Plaster Base - Type LW2X (finish rating 20 min), Water Rated - Type LW2X (finish rating 20 min), Sheathing - Type LW2X (finish rating 20 min), Soffit - Type LW2X (finish rating 20 min)

NATIONAL GYPSUM CO — eXP-C, FSK, FSK-C, FSK-G, FSL, FSLX, FSMR-C, FSW-2, FSW-3, FSW-C, FSW-G, FSW-8, RSX

NATIONAL GYPSUM CO — Riyadh, Saudi Arabia — Type FR or WR.

PABCO BUILDING PRODUCTS L L C, DBA PABCO GYPSUM — Types C, PG-3, PG-4, PG-5, PG-6, PG-9, PG-C, PG-11, Type PGI (Finish Rating 26 minutes).

PANEL REY S A — Types PRC, PRC2

SIAM GYPSUM INDUSTRY (SARABURI) CO LTD — Type EX-1

THAI GYPSUM PRODUCTS PCL — Type C, Type X

UNITED STATES GYPSUM CO — Types C, IP-X1, IP-X2, IPC-AR, SCX, WRX

USG BORAL DRYWALL SFZ LLC — Types C, SCX

USG MEXICO S A DE C V — Types C, IP-X1, IP-X2, IPC-AR, SCX, WRX

5A. **Gypsum Board*** — (Finish Rating - 16 min.) Required when Air Balance Inc. Type 299 ceiling damper (Item 4) is installed. Nom 5/8 in. thick, 48 in. wide gypsum board, installed with long dimension perpendicular to joists. Gypsum board secured with 1-7/8 in. long, 6d cement coated nails spaced 6 in. OC with the first nails located 1/2 in. and 3 in. from the board edges.

UNITED STATES GYPSUM CO — Type C

USG BORAL DRYWALL SFZ LLC — Types C, SCX

USG MEXICO S A DE C V — Type C

5B. **Gypsum Board*** — Nom 3/4 in. thick, 48 in. wide gypsum board, installed as described in Item 5 with nails length increased to 2 in.

PABCO BUILDING PRODUCTS L L C, DBA PABCO GYPSUM — Type PG-13

5C. **Gypsum Board* (As an alternative to Item 5)** — Nom 5/8 in. thick, 48 in. wide gypsum board, installed with long dimension perpendicular to joists. Gypsum board secured with 1 in. long Type S screws spaced 6 in. OC.

UNITED STATES GYPSUM CO — ULIX

5D. **Gypsum Board* (As an alternative to Item 5A)** — Required when Air Balance Inc. Type 299 ceiling damper (Item 4) is installed. Nom 5/8 in. thick, 48 in. wide gypsum board, installed with long dimension perpendicular to joists. Gypsum board secured with 1-7/8 in. long Type S screws spaced 6 in. OC with the first screws located 1/2 in. and 3 in. from the board edges.

UNITED STATES GYPSUM CO — ULIX

5E. **Gypsum Board* (As an alternative to Item 5)** — Nom 5/8 in. thick, 48 in. wide gypsum board, installed with long dimension perpendicular to joists. Gypsum board secured with 2 in. long, No. 6 screws spaced 6 in. OC.

NATIONAL GYPSUM CO — FSW, FSW-6

6. **Finishing System — (Not Shown)** — Vinyl, dry or premixed joint compound, applied in two coats to joints and screw-heads. Nom 2 in. wide paper tape embedded in first layer of compound over all joints. As an alternate, nom 3/32 in. thick veneer plaster may be applied to the entire surface of gypsum board.

7. **Grille** — Steel grille, installed in accordance with the installation instructions provided with the ceiling damper.

8. **Steel Corner Fasteners** — (Optional, Not Shown) — Used to attach ends of gypsum board at wall intersection where joists run parallel to wall. Channel shaped, 2 in. long by 1 in. high on the back side with two 1/8 in. wide cleats protruding into the 5/8 in. wide channel, fabricated from 24 gauge galvanized steel. Fasteners nailed to face of wall bearing plate through fastener tab with one No. 6d cement coated nail, spaced not greater than 16 in. OC and 2 in. from edge of gypsum board. Fasteners covered with gypsum board facing applied to intersecting wall.

9. **Discrete Products Installed in Air-handling Spaces*** — Automatic Balancing Valve/Damper — (Not Shown - Optional) — For use with item 4, Ruskin Company's Model CFD7 damper (CABS). Ceiling damper to be provided with plenum box per damper manufacturer's instructions with side outlet only. Entire assembly to be installed into any UL Class 0 or Class 1 flexible air duct in accordance with the instructions provided by the automatic balancing valve/damper manufacturer.

METAL INDUSTRIES INC — Model ABV-4, ABV-5, ABV-6

*** Indicates such products shall bear the UL or cUL Certification Mark for jurisdictions employing the UL or cUL Certification (such as Canada), respectively.**

Last Updated on 2024-09-24

The appearance of a company's name or product in this database does not in itself assure that products so identified have been manufactured under UL Solutions' Follow - Up Service. Only those products bearing the UL Mark should be considered to be Certified and covered under UL Solutions' Follow - Up Service. Always look for the Mark on the product.

UL Solutions permits the reproduction of the material contained in Product iQ subject to the following conditions: 1. The Guide Information, Assemblies, Constructions, Designs, Systems, and/or Certifications (files) must be presented in their entirety and in a non-misleading manner, without any manipulation of the data (or drawings). 2. The statement "Reprinted from Product iQ with permission from UL Solutions" must appear adjacent to the extracted material. In addition, the reprinted material must include a copyright notice in the following format: "©2024 UL LLC."

Design/System/Construction/Assembly Usage Disclaimer

- Authorities Having Jurisdiction should be consulted in all cases as to the particular requirements covering the installation and use of UL Certified products, equipment, system, devices, and materials.
- Authorities Having Jurisdiction should be consulted before construction.
- Fire resistance assemblies and products are developed by the design submitter and have been investigated by UL for compliance with applicable requirements. The published information cannot always address every construction nuance encountered in the field.
- When field issues arise, it is recommended the first contact for assistance be the technical service staff provided by the product manufacturer noted for the design. Users of fire resistance assemblies are advised to consult the general Guide Information for each product category and each group of assemblies. The Guide Information includes specifics concerning alternate materials and alternate methods of construction.
- Only products which bear UL's Mark are considered Certified.

BXUV - Fire Resistance Ratings - ANSI/UL 263 Certified for United States**BXUV7 - Fire Resistance Ratings - CAN/ULC-S101 Certified for Canada**

[See General Information for Fire-resistance Ratings - ANSI/UL 263 Certified for United States Design Criteria and Allowable Variances](#)

[See General Information for Fire Resistance Ratings - CAN/ULC-S101 Certified for Canada Design Criteria and Allowable Variances](#)

Design No. L528

September 2, 2024

Unrestrained Assembly Rating - 1 Hr.**Finish Rating - 22 Min.**

This design was evaluated using a load design method other than the Limit States Design Method (e.g., Working Stress Design Method). For jurisdictions employing the Limit States Design Method, such as Canada, a load restriction factor shall be used — See Guide [BXUV](#) or [BXUV7](#)

*** Indicates such products shall bear the UL or cUL Certification Mark for jurisdictions employing the UL or cUL Certification (such as Canada), respectively.**

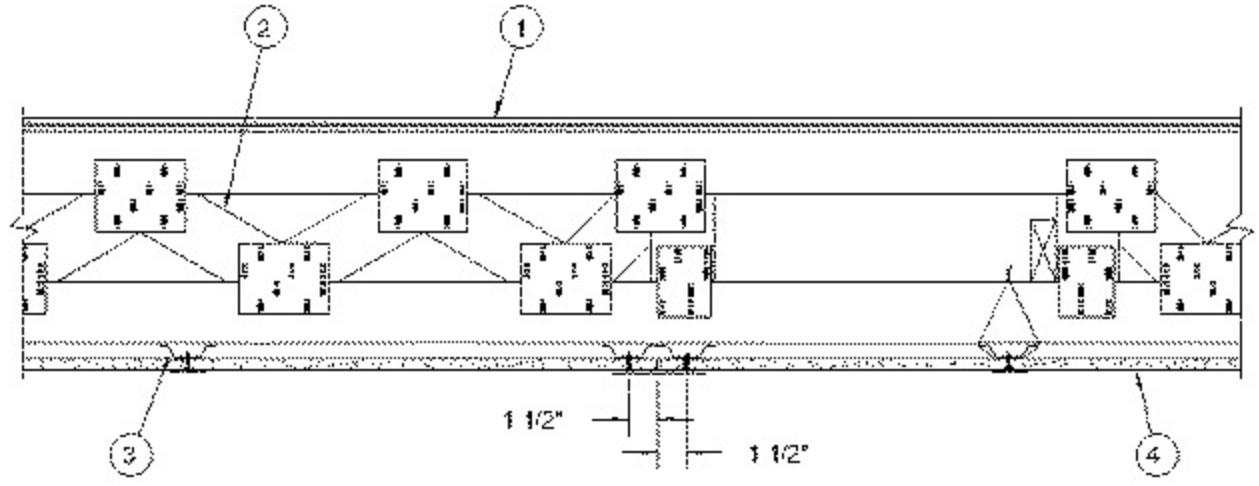
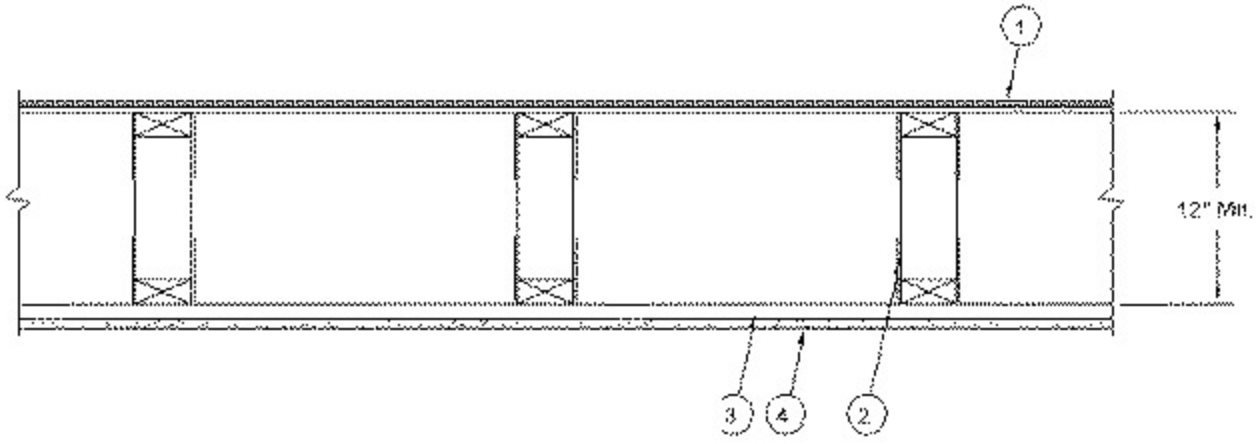
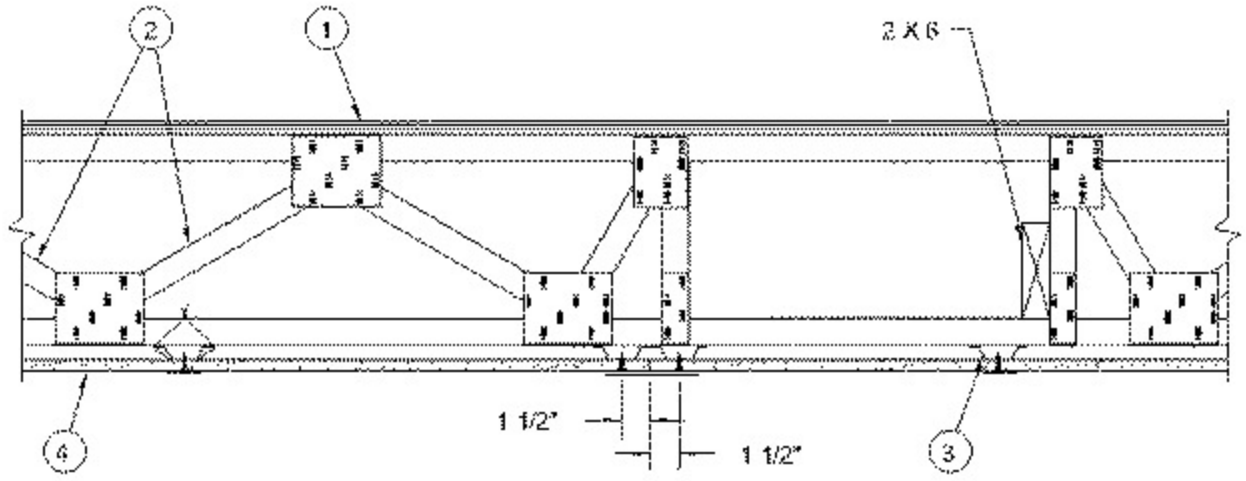

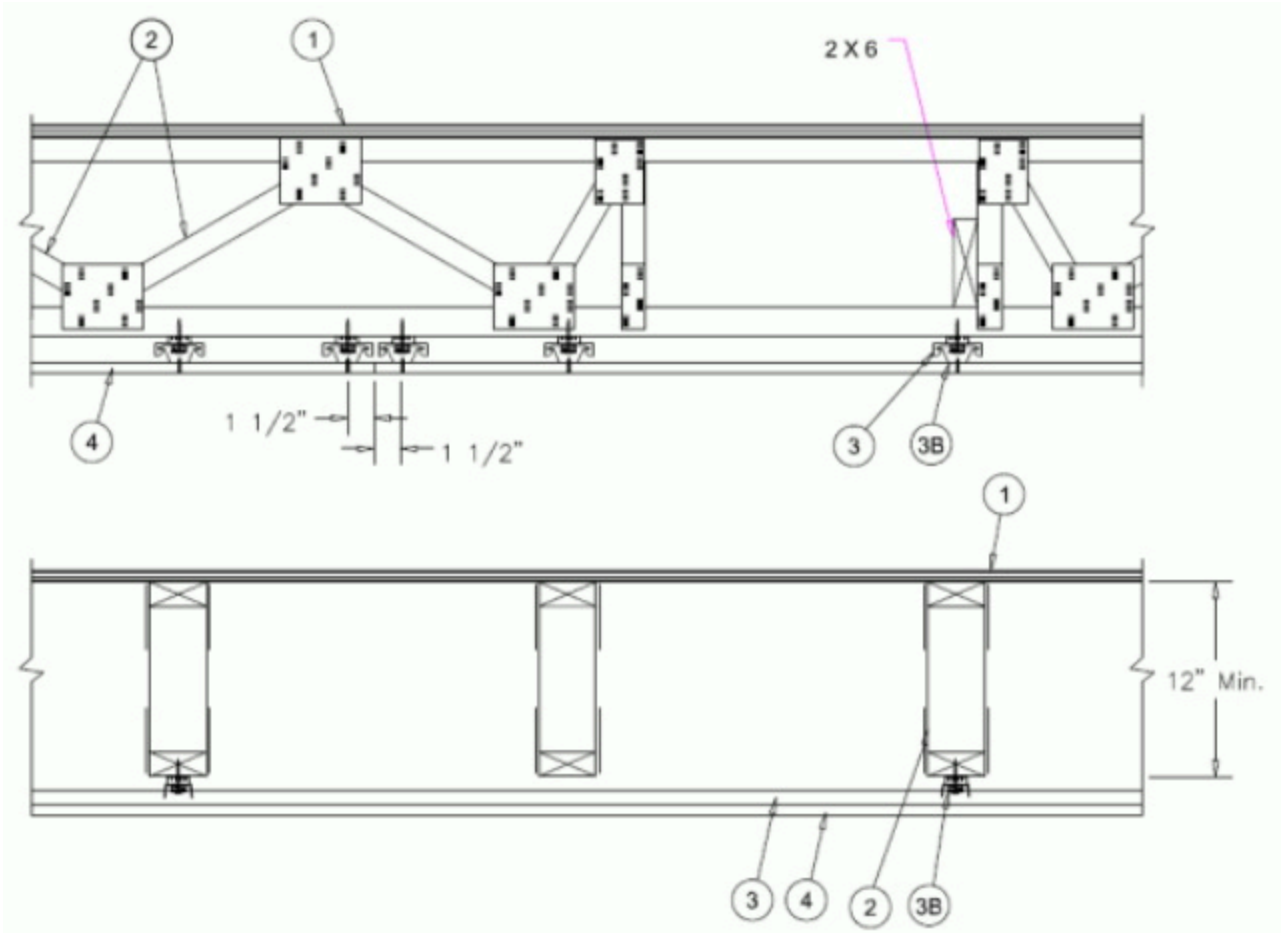
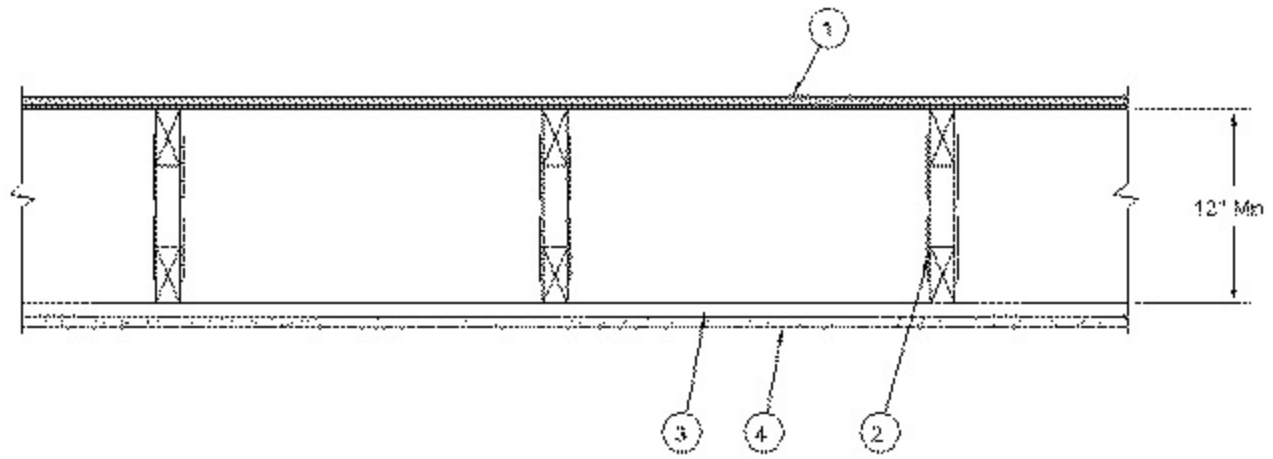

1. **Flooring System** — The flooring system shall consist of one of the following:

System No. 1

Subflooring — Min 23/32 in. thick T & G wood structural panels, min grade "Underlayment" or "Single-Floor". Face grain of plywood or strength axis of panels to be perpendicular to the trusses with end joints staggered 4 ft. Panels secured to trusses with construction adhesive and No. 6d ringed shank nails spaced 12 in. OC along each truss. TetraGRIP™ nails measuring 2-3/8 in. long, 0.113 in. diameter, 0.272 in. round head, and helically threaded shank with barbed features on the helix meeting ASTM F1667 and having equal or greater withdrawal and lateral resistance strength may be substituted for the 6d nails. Staples having equal or greater withdrawal and lateral resistance strength may be substituted for the 6d nails.

System No. 2

Subflooring — Min 23/32 in. thick T & G wood structural panels, min grade "Underlayment" or "Single-Floor". Face grain of plywood or strength axis of panels to be perpendicular to the trusses with end joints staggered 4 ft. Panels secured to trusses with construction adhesive and No. 6d ringed shank nails spaced 12 in. OC along each truss. TetraGRIP™ nails measuring 2-3/8 in. long, 0.113 in. diameter, 0.272 in. round head, and helically threaded shank with barbed features on the helix meeting ASTM F1667 and having equal or greater withdrawal and lateral resistance strength may be substituted for the 6d nails. Staples having equal or greater withdrawal and lateral resistance strength may be substituted for the 6d nails.

Vapor Barrier — (Optional) — Commercial asphalt saturated felt, 0.030 in. thick.

Vapor Barrier — (Optional) — Nom 0.010 in. thick commercial rosin-sized building paper.

Finish Flooring — Min 3/4 in. thickness of lightweight insulating concrete with **Perlite Aggregate*** or **Vermiculite Aggregate***, or gypsum concrete.

See **Perlite Aggregate** (CFFX) and **Vermiculite Aggregate** (CJZZ) categories for names of manufacturers.

System No. 3

Subflooring — Min 23/32 in. thick wood structural panels, min grade "C-D" or "Sheathing". Face grain of plywood or strength axis of panels to be perpendicular to the trusses with joints staggered.

Vapor Barrier — (Optional) — Commercial asphalt saturated felt, 0.030 in. thick.

Floor Mat Materials* — (Optional)— Floor mat material nom 5/64 in. (2 mm) thick adhered to subfloor with Hacker Floor Primer. Primer to be applied to the surface of the mat prior to the placement of a min 1 in. of floor-topping mixture.

HACKER INDUSTRIES INC — Type Hacker Sound-Mat.

Alternate Floor Mat Materials — (Optional) — Floor mat material nom 1/4 in. (6 mm) thick adhered to subfloor with Hacker Floor Primer. Primer to be applied to the surface of the mat prior to the placement of a min 1-1/4 in. (32 mm) of floor-topping mixture.

HACKER INDUSTRIES INC — Type Hacker Sound-Mat II.

Alternate Floor Mat Materials — (Optional) — Floor mat material nom 1/8 in. (3 mm) thick loose laid over the subfloor. Floor topping thickness shall be a min of 3/4 in. (19 mm)

HACKER INDUSTRIES INC — FIRM-FILL SCM 125

Alternate Floor Mat Materials — (Optional) — Floor mat material nom 1/4 in. (6 mm) thick loose laid over the subfloor. Floor topping thickness shall be a min of 1 in. (25 mm)

HACKER INDUSTRIES INC — Type FIRM-FILL SCM 250, Quiet Qurl 55/025

Alternate Floor Mat Materials — (Optional) — Floor mat material nom 3/8 in. (10 mm) thick loose laid over the subfloor. Floor topping thickness shall be a min of 1-1/4 in. (32 mm)

HACKER INDUSTRIES INC — FIRM-FILL SCM 400, Quiet Qurl 60/040

Alternate Floor Mat Materials — (Optional) — Floor mat material nom 3/4 in. (19 mm) thick loose laid over the subfloor. Floor topping thickness shall be a min of 1-1/2 in. (38 mm)

HACKER INDUSTRIES INC — Type FIRM-FILL SCM 750, Quiet Qurl 65/075

Metal Lath — (Optional) — For use with 3/8 in. (10 mm) floor mat materials, 3/8 in. expanded steel diamond mesh, 3.4 lbs/sq yd placed over the floor mat material. Hacker Floor Primer to be applied prior to the placement of the metal lath. When metal lath is used, floor topping thickness a nom 1-1/4 in. over the floor mat.

Finish Flooring — Floor Topping Mixture* — Min 3/4 in. thickness of floor topping mixture having a min compressive strength of 1100 psi. Mixture shall consist of 6.8 gal of water to 80 lbs of floor topping mixture to 1.9 cu ft of sand.

HACKER INDUSTRIES INC — Firm-Fill Gypsum Concrete, Firm-Fill 2010, Firm-Fill 3310, Firm-Fill 4010, Firm-Fill High Strength, Gyp-Span Radiant

System No. 4

Subflooring — Min 23/32 in. thick wood structural panels, min grade "C-D" or "Sheathing". Face grain of plywood or strength axis of panels to be perpendicular to the trusses with joints staggered.

Vapor Barrier — (Optional) — Commercial asphalt saturated felt, 0.010 in. thick.

Finish Flooring — Floor Topping Mixture* — Min 3/4 in. thickness of floor topping mixture having a minimum compressive strength of 1800 psi. Refer to manufacturer's instructions accompanying the material for specific mix design.

UNITED STATES GYPSUM CO — Types LRK, HSLRK, CSD

LATICRETE SUPERCAP L L C — Types LRK, HSLRK

USG MEXICO S A D E C V — Types LRK, HSLRK, CSD

Floor Mat Materials* — (Optional) — Floor mat material loose laid over the subfloor. Refer to manufacturer's instructions regarding the minimum thickness of floor topping over each floor mat material.

UNITED STATES GYPSUM CO — Types SAM, LEVELROCK® Brand Sound Reduction Board, LEVELROCK® Brand Floor Underlayment SRM-25

Alternate Floor Mat Materials* — (Optional) — Floor mat material loose laid over the subfloor. Refer to manufacturer's instructions regarding minimum thickness of floor topping over floor mat.

GRASSWORX L L C — SC Types

Alternate Floor Mat Material* — (Optional) - Floor mat material nominal 3/8 in. thick loose laid over the subfloor. Floor topping shall be a min 3/4 in. thick.

System No. 5

Subflooring — Min 23/32 in. thick wood structural panels, min grade "C-D" or "Sheathing". Face grain of plywood or strength axis of panels to be perpendicular to the trusses with joints staggered.

Vapor Barrier — (Optional) — Commercial asphalt saturated felt, 0.030 in. thick.

Finish Flooring — Floor Topping Mixture* — Min 1-1/2 in. thickness of floor topping mixture having a min compressive strength of 1000 psi and a cast density of 100 plus or minus 5 pcf. Foam concentrate mixed 40:1 by volume with water and expanded at 100 psi through nozzle. Mixture shall consist of 1.4 cu feet of preformed foam concentrate to 94 lbs Type I Portland cement, 300 lbs of sand with 5-1/2 gal of water.

ELASTIZELL CORP OF AMERICA — Type FF

System No. 6

Subflooring — Min 23/32 in. thick wood structural panels, min grade "C-D" or "Sheathing". Face grain of plywood or strength axis of panels to be perpendicular to the trusses with joints staggered.

Vapor Barrier — (Optional) — Commercial asphalt saturated felt, 0.030 in. thick.

Finish Flooring — Floor Topping Mixture* — Min 1-1/2 in. thickness of floor topping mixture having a min compressive strength of 1000 psi and a cast density of 100 plus or minus 5 pcf. Foam concentrate mixed 40:1 by volume with water and expanded at 100 psi through nozzle. Mixture shall consist of 1.2 cu feet of preformed foam concentrate to 94 lbs Type I Portland cement, 300 lbs of sand with 5-1/2 gal of water.

AERIX INDUSTRIES — Floor Topping Mixture

System No. 7

Deleted.

System No. 8

Subflooring — Min 23/32 in. thick wood structural panels, min grade "C-D" or "Sheathing". Face grain of plywood or strength axis of panels to be perpendicular to the trusses with joints staggered.

Vapor Barrier — (Optional) — Commercial asphalt saturated felt, 0.030 in. thick.

Finish Flooring - Floor Topping Mixture* — Min 3/4 in. thickness of floor topping mixture having a minimum compressive strength of 1500 psi. Refer to manufacturer's instructions regarding the minimum thickness of floor topping over each floor mat material.

MAXXON CORP — Types Maxxon Standard and Maxxon High Strength

Floor Mat Materials* — (Optional) - Floor mat material loose laid over the subfloor. Refer to manufacturer's instructions regarding the minimum thickness of floor topping over each floor mat material.

MAXXON CORP — Type Encapsulated Sound Mat.

Floor Mat Reinforcement — (Optional) - Refer to manufacturer's instructions regarding minimum thickness of floor topping for use with floor mat reinforcement.

Metal Lath — (Optional) - 3/8 in. expanded galvanized steel diamond mesh, 3.4 lbs/sq yd loose laid over the floor mat material.

Fiber Glass Reinforcement - (Optional, Not Shown) - 0.015 in. thick PVC coated non-woven fiberglass mesh, 0.368 lbs/sq yd loose laid over the floor mat material.

System No. 9

Subflooring — Min 23/32 in. thick wood structural panels, min grade "C-D" or "Sheathing". Face grain of plywood or strength axis of panels to be perpendicular to the trusses with joints staggered.

Vapor Barrier — (Optional) — Commercial asphalt saturated felt, 0.030 in. thick.

Finish Flooring — Floor Topping Mixture* — Min 3/4 in. thickness of floor topping mixture having a min compressive strength of 1000 psi. Mixture shall consist of 5 to 8 gal of water to 80 lbs of floor topping mixture to 2.1 cu ft of sand. Refer to the manufacturer's instructions accompanying the material and/or contact the manufacturer's technical support for specific mix design and minimum thickness recommended for use with eligible floor mat(s).

ULTRA QUIET FLOORS — UQF-A, UQF-Super Blend, UQF-Plus 200

System No. 10

Subflooring — Min 23/32 in. thick wood structural panels, min grade "C-D" or "Sheathing". Face grain of plywood or strength axis of panels to be perpendicular to the trusses with joints staggered.

Vapor Barrier — (Optional) Commercial asphalt saturated felt, 0.030 in. thick.

Finish Flooring — Floor Topping Mixture* — Min 3/4 in. thickness of floor topping having a min compressive strength of 1000 psi. Refer to manufacturer's instructions accompanying the material for specific mix design.

FORMULATED MATERIALS LLC — Types FR-25, FR-30, SiteMix, and Treadstone Advantage

Alternate Floor Mat Material* — (Optional) Floor mat material nominal 2 - 9.5 mm thick loose laid over the subfloor. Floor topping shall be a min of 3/4 in.

FORMULATED MATERIALS LLC — Types M1, M2, M3, Elite, Duo, R1, and R2

System No. 11

Subflooring — Min 1 by 6 in. T & G lumber fastened diagonally to trusses, or min 15/32 in. thick plywood or min 7/16 in. thick oriented strand board (OSB) wood structural panels, min grade "C-D" or "Sheathing". Face grain of plywood or strength axis of panel to be perpendicular to trusses with joints staggered.

Finish Floor - Mineral and Fiber Board* — Min 1/2 in. thick, supplied in sizes ranging from 3 ft by 4 ft to 8 ft by 12 ft. All joints to be staggered a min of 12 in. with adjacent sub-floor joints.

HOMASOTE CO — Type 440-32 Mineral and Fiber Board

System No. 12

Subflooring — Min 23/32 in. thick wood structural panels, min grade "C-D" or "Sheathing". Face grain of plywood or strength axis of panels to be perpendicular to the trusses with joints staggered.

Vapor Barrier — (Optional) — Commercial asphalt saturated felt, 0.030 in. thick.

Finish Flooring — Floor Topping Mixture* — Min 3/4 in. thickness of floor topping having a min compressive strength of 1000 psi. Refer to manufacturer's instructions accompanying the material for specific mix design.

ARCOSA SPECIALTY MATERIALS — AccuCrete® Types NexGen, Green, Prime and PrePour, AccuRadiant®, AccuLevel® Types G40, G50 and SD30

Alternate Floor Mat Material* — (Optional) — Floor mat material nominal 2 - 9.5 mm thick loose laid over the subfloor. Floor topping shall be a min of 3/4 in.

ARCOSA SPECIALTY MATERIALS — AccuQuiet® Types D13, D-18, D25, DX38, EM.125, EM.125S, EM.250, EM.250S, EM.375, EM.375S, EM.750, and EM.750S.

System No. 13

Subflooring — Min 15/32 in. thick wood structural panels, min grade "C-D" or "Sheathing". Face grain of plywood or strength axis of panels to be perpendicular to the joists with joints staggered.

Vapor Barrier — (Optional) — Commercial asphalt saturated felt, 0.030 in. thick.

Vapor Barrier — (Optional) — Nom 0.010 in. thick commercial rosin-sized building paper.

Finish Flooring* — Min 3/4 in. thickness of any Floor Topping Mixture bearing the UL Classification Marking as to Fire Resistance. See **Floor- and Roof-Topping Mixtures** (CCOX) category for names of Classified Companies.

Floor Mat Materials* — (Optional) — Nom. 1/4 in. thick loose laid over the subfloor. Floor topping thickness shall be a minimum of 3/4 in.

KEENE BUILDING PRODUCTS CO INC — Type Quiet Qurl 55/025 and Quiet Qurl 55/025 N

Alternate Floor Mat Materials* — (Optional) — Floor mat material Nom. 3/8 in. thick loose laid over the subfloor. Floor topping thickness shall be a minimum of 1 in.

KEENE BUILDING PRODUCTS CO INC — Type Quiet Qurl 60/040 and Quiet Qurl 60/040 N

Alternate Floor Mat Materials* — (Optional) — Floor mat material Nom. 3/4 in. thick loose laid over the subfloor. Floor topping thickness shall be a minimum of 1-1/2 in.

KEENE BUILDING PRODUCTS CO INC — Type Quiet Qurl 65/075, Quiet Qurl 65/075 N

Alternate Floor Mat Materials* — (Optional) — Floor mat material Nom. 1/8 in. thick loose laid over the subfloor. Floor topping thickness shall be a minimum of 3/4 in.

KEENE BUILDING PRODUCTS CO INC — Type Quiet Qurl 52/013 and Quiet Qurl 52/013 N

Alternate Floor Mat Materials* — (Optional) — Floor mat material Nom. 1/4 in. entangled net core with a compressible fabric attached to the bottom loose laid over the subfloor. Floor topping thickness shall be a minimum of 1 in.

KEENE BUILDING PRODUCTS CO INC — Quiet Qurl 55/025 MT and Quiet Qurl 55/025 N MT

System No. 14

Subflooring — Min 23/32 in. thick T&G wood structural panels, min grade "Underlayment" or "Single-Floor". Face grain of plywood or strength axis of panels to be perpendicular to the trusses with end joints staggered 4 ft. Panels secured to trusses with construction adhesive and No. 6d ringed shank nails spaced 12 in. OC along each truss. TetraGRIP™ nails measuring 2-3/8 in. long, 0.113 in. diameter, 0.272 in. round head, and helically threaded shank with barbed features on the helix meeting ASTM F1667 and having equal or greater withdrawal and lateral resistance strength may be substituted for the 6d nails. Staples having equal or greater withdrawal and lateral resistance strength may be substituted for the 6d nails.

Gypsum Board* — One layer of nom 5/8 in. thick, 4 ft wide gypsum board, installed with long dimension perpendicular to joists. Gypsum board secured with 1 in. long No. 6 Type W bugle head steel screws spaced 12 in. OC and located a min of 1-1/2 in. from side and end joints. The joints of the gypsum board are to be staggered a minimum of 12 inches from the joints of the subfloor.

GEORGIA-PACIFIC GYPSUM L L C — Type DS

Floor Mat Materials* — (As an alternate to the single layer gypsum board) — Floor mat material loose laid over the subfloor.

MAXXON CORP — Type Encapsulated Sound Mat.

Gypsum Board* — (For use when floor mat is used) Two layers of nom 5/8 in. thick, 4 ft wide gypsum board, installed with long dimension perpendicular to joists on top of the floor mat material. Gypsum board secured to each other with 1 in. long No. 6 Type G bugle head steel screws spaced 12 in. OC and located a min of 1-1/2 in. from side and end joints. The joints of the gypsum board are to be staggered a minimum of 12 inches in between layers and from the joints of the subfloor.

GEORGIA-PACIFIC GYPSUM L L C — Type DS

System No. 15

Subflooring — Min 23/32 in. thick wood structural panels, min grade "C-D" or "Sheathing". Face grain of plywood or strength axis of panels to be perpendicular to the trusses with joints staggered.

Vapor Barrier — (Optional) — Commercial asphalt saturated felt, 0.030 in. thick.

Finish Flooring - Floor Topping Mixture* — Min 3/4 in. thickness of floor topping having a min compressive strength of 1000 psi. Refer to manufacturer's instructions accompanying the material for specific mix design.

DEPENDABLE LLC — GSL M3.4, GSL K2.6, GSL-CSD, GSL RH and SKIMFLOW

Floor Mat Materials* — (Optional) — Nom. 1/4 in. thick loose laid over the subfloor. Floor topping thickness shall be a minimum of 3/4 in.

KEENE BUILDING PRODUCTS CO INC — Type Quiet Qurl 55/025 and Quiet Qurl 55/025 N

Alternate Floor Mat Materials* — (Optional) — Floor mat material Nom. 3/8 in. thick loose laid over the subfloor. Floor topping thickness shall be a minimum of 1 in.

KEENE BUILDING PRODUCTS CO INC — Type Quiet Qurl 60/040 and Quiet Qurl 60/040 N

Alternate Floor Mat Materials* — (Optional) — Floor mat material Nom. 3/4 in. thick loose laid over the subfloor. Floor topping thickness shall be a minimum of 1-1/2 in.

KEENE BUILDING PRODUCTS CO INC — Type Quiet Qurl 65/075, Quiet Qurl 65/075 N

Alternate Floor Mat Materials* — (Optional) — Floor mat material Nom. 1/8 in. thick loose laid over the subfloor. Floor topping thickness shall be a minimum of 3/4 in.

KEENE BUILDING PRODUCTS CO INC — Type Quiet Qurl 52/013 and Quiet Qurl 52/013 N

Alternate Floor Mat Materials* — (Optional) — Floor mat material Nom. 1/4 in. entangled net core with a compressible fabric attached to the bottom loose laid over the subfloor. Floor topping thickness shall be a minimum of 1 in.

KEENE BUILDING PRODUCTS CO INC — Quiet Qurl 55/025 MT and Quiet Qurl 55/025 N MT

System No. 16

Subflooring — Min 23/32 in. thick wood structural panels, min grade "C-D" or "Sheathing". Face grain of plywood or strength axis of panels to be perpendicular to the joists with joints staggered.

Vapor Barrier — (Optional) — Commercial asphalt saturated felt, 0.030 in. thick.

Vapor Barrier — (Optional) — Nom 0.010 in. thick commercial rosin-sized building paper.

Finish Flooring* — Min 3/4 in. thickness of any Floor Topping Mixture bearing the UL Classification Marking as to Fire Resistance. See **Floor- and Roof-Topping Mixtures** (CCOX) category for names of Classified Companies. Refer to the manufacturer's instructions accompanying the material and/or contact the manufacturer's technical support for specific mix design and minimum thickness recommended for use with eligible floor mat(s).

Floor Mat Materials* — (Optional) — Nom 3/32 in. thick loose laid over the subfloor. Floor topping thickness shall be a minimum of 3/4 in.

PLITEQ INC — Type GenieMat RST02

Floor Mat Materials* — (Optional) — Nom 3/16 in. thick loose laid over the subfloor. Floor topping thickness shall be a minimum of 3/4 in.

PLITEQ INC — Type GenieMat FF03NP

Floor Mat Materials* — (Optional) — Nom 1/4 in. thick loose laid over the subfloor. Floor topping thickness shall be a minimum of 3/4 in.

PLITEQ INC — Type GenieMat FF06

Floor Mat Materials* — (Optional) — Nom 3/8 in. thick loose laid over the subfloor. Floor topping thickness shall be a minimum of 1 in.

PLITEQ INC — Type GenieMat FF10

Floor Mat Materials* — (Optional) — Nom 3/4 in. thick loose laid over the subfloor. Floor topping thickness shall be a minimum of 1-1/2 in.

PLITEQ INC — Type GenieMat FF17

Floor Mat Materials* — (Optional) — Nom 1 in. thick loose laid over the subfloor. Floor topping thickness shall be a minimum of 1-1/2 in.

PLITEQ INC — Type GenieMat FF25

System No. 17

Subflooring — Nom. 1-1/2 in. thick T & G laminated composite plywood sub-floor panels to be perpendicular to the trusses with end joints staggered 4 ft. End joints centered over top chord of trusses. Subfloor panels secured to trusses with construction adhesive and #8 by 3 in. wood screws spaced 12 in. OC in the field and 6 in. OC at the end joints.

RSP INDUSTRIES INC — SAP board

System No. 18

Subflooring — Min 15/32 in. thick wood structural panels, min grade "Underlayment" or "Single-Floor". Panels secured to trusses with construction adhesive and No. 6d ringed shank nails spaced 12 in. OC along each truss.

Wall and Partition Facings and Accessories* - Sound Barrier (Optional) — Acoustic Sleeper pads stapled to the top of the subfloor, the bottom of the finish floor, or to 5/16 in. thick by 1-1/2 in. wide wood strips and centered over wood trusses. Acoustic Sleeper pads are to be spaced appropriately so that the finish floor panels are fastened through Acoustic Sleeper pads to the trusses.

STC ARCHITECTURAL PRODUCTS L L C DBA STC SOUND CONTROL — Acoustic Sleeper

Finish Floor — Min 23/32 in. thick T & G wood structural panels, min grade "Underlayment" or "Single-Floor". Face grain of plywood or strength axis of panels to be perpendicular to the trusses with end joints staggered 4 ft. Butt joints of panels have the option of being sealed with any UL Classified caulk or sealant found under - Fill, Void or Cavity Materials* (XHHW).

System No. 19

Structural Cement-Fiber Units* — For use with **UNITED STATES GYPSUM CO** Types C, IP-X2, IPC-AR and ULIX or **AMERICAN GYPSUM CO** Type AG-C. gypsum boards only. Nom 3/4 in. thick, with long edges tongue and grooved. Long dimension of panels to be perpendicular to wood trusses with end joints staggered a min of 2 ft and centered over the trusses. Panels secured to wood trusses with 1-5/8 in. long, No. 8, self- countersinking wood screw spaced a max of 12 in. OC in the field with a screw located 1 in. and 2 in. from each edge, and 8 in. OC on the perimeter with a screw located 2 in. from each edge, located 1/2 in. from the end edges of the panel.

UNITED STATES GYPSUM CO — Types STRUCTO-CRETE, USGSP

System No. 20

Subflooring — Min 23/32 in. thick T & G wood structural panels, min grade "Underlayment" or "Single-Floor". Face grain of plywood or strength axis of panels to be perpendicular to the trusses with end joints staggered 4 ft. Panels secured to trusses with construction adhesive and No. 6d ringed shank nails spaced 12 in. OC along each truss. TetraGRIP™ nails measuring 2-3/8 in. long, 0.113 in. diameter, 0.272 in. round head, and helically threaded shank with barbed features on the helix meeting ASTM F1667 and having equal or greater withdrawal and lateral resistance strength may be substituted for the 6d nails. Staples having equal or greater withdrawal and lateral resistance strength may be substituted for the 6d nails.

Finish Flooring - Floor Topping Mixture* — Min 1 in. thickness of floor topping mixture having a min compressive strength of 4500 psi. Refer to manufacturer's instructions accompanying the material for specific mix design.

SIKA DEUTSCHLAND GMBH — Type SCHONOX AP Rapid Plus

System No. 21

Subflooring — Min 23/32 in. thick T & G wood structural panels, min grade "Underlayment" or "Single-Floor". Face grain of plywood or strength axis of panels to be perpendicular to the trusses with end joints staggered 4 ft. Panels secured to trusses with construction adhesive and No. 6d ringed shank nails spaced 12 in. OC along each truss. TetraGRIP™ nails measuring 2-3/8 in. long, 0.113 in.

diameter, 0.272 in. round head, and helically threaded shank with barbed features on the helix meeting ASTM F1667 and having equal or greater withdrawal and lateral resistance strength may be substituted for the 6d nails. Staples having equal or greater withdrawal and lateral resistance strength may be substituted for the 6d nails.

Vapor Barrier — (Optional) - Commercial asphalt saturated felt, 0.030 in. thick.

Vapor Barrier — (Optional) - Nom 0.010 in. thick commercial rosin-sized building paper.

Finish Flooring - Floor Topping Mixture* — Min 3/4 in. thickness of any Floor Topping Mixture bearing the UL Classification Marking as to Fire Resistance. See Floor- and Roof-Topping Mixtures (CCOX) category for names of Classified Companies. Refer to the manufacturer's instructions accompanying the material and/or contact the manufacturer's technical support for specific mix design and minimum thickness recommended for use with eligible floor mat(s).

Floor Mat Materials* — (Optional, Not Shown) - Floor mat material loose laid over the subfloor. Refer to manufacturer's instructions regarding the minimum thickness of floor topping over each floor mat material.

Freudenberg Performance Materials LP — EnkaSonic® by Colbond a member of the Low & Bonar group Types 125, 250, 250 Plus, 400, 400 Plus, 750, and 750 Plus.

Floor Mat Reinforcement — (Optional) - Refer to manufacturer's instructions regarding minimum thickness of floor topping for use with floor mat reinforcement.

Metal Lath — (Optional) — Expanded steel diamond mesh, 2.5 lb / sq yd loose laid over floor mat material.

Fiberglass Mesh Reinforcement — (Optional) — Coated non-woven glass fiber mesh grid loose laid over floor mat material.

System No. 22

Subflooring — Min 23/32 in. thick T & G wood structural panels described and installed as shown in System No. 1.

Finish Floor - Building Units* — Min 1/2 in. thick magnesium oxide panels installed parallel, perpendicular, or diagonally to trusses with panel edges offset a min of 4 in. between subfloor and magnesium oxide panels. Panels secured to subfloor with construction adhesive and corrosion resistant fasteners, spaced 12 in. OC around the perimeter and in the field of the panel. Fasteners must be placed no closer than 1/2 in. from all panel edges and no closer than 2 in. from panel corners

HUBER ENGINEERED WOODS L L C — Type 1/2 in. Square Edge Exacor™ Board

System No. 23

Subflooring — Min 15/32 in. thick wood structural panels, min grade "C-D" or "Sheathing". Face grain of plywood or strength axis of panels to be perpendicular to the trusses with joints staggered. Fastened with 8d ringed shank nails spaced 12 in. OC along each truss.

Finish Floor - Building Units* — Min 1/2 in. thick, supplied in 4 by 8 ft panels, fastened to trusses through subfloor with 8d ringed shank nails spaced a max of 12 in. OC. All joints to be staggered a min of 12 in. with adjacent sub-floor joints.

ECTEK INTERNATIONAL INC — Type MegaBoard, 1/2 in. thick

System No. 24

Subflooring — **Building Units*** — Nom 3/4 in. thick, tongue and grooved boards. Long dimension of boards to be perpendicular to wood trusses with end joints staggered a min of 4 ft. and centered over the trusses. Boards secured to trusses with min 2 in. long screws or 2 in. x 0.113 in. Ring Shank nails spaced a max of 12 in. OC in the field with screws/nails located 1 in. from long edge, and max 8 in. OC along the end joints with screws/nails located 1/2 in. from end joint.

ECTEK INTERNATIONAL INC — Type MegaBoard, 3/4 in. thick

Finish Floor (optional) — **Building Units*** — Min 1/2 in. thick, supplied in 4 by 8 ft panels, fastened to trusses through subfloor with 2-3/8 in. long 8d ringed shank nails spaced a max of 12 in. OC. All joints to be staggered a min of 12 in. with adjacent sub-floor joints.

ECTEK INTERNATIONAL INC — Type MegaBoard, 1/2 in. thick

System No. 25

Subflooring — Min 23/32 in. thick T & G wood structural panels, min grade "Underlayment" or "Single-Floor". Face grain of plywood or strength axis of panels to be perpendicular to the trusses with end joints staggered 4 ft. Panels secured to trusses with construction adhesive and No. 6d ringed shank nails spaced 12 in. OC along each truss. TetraGRIP™ nails measuring 2-3/8 in. long, 0.113 in. diameter, 0.272 in. round head, and helically threaded shank with barbed features on the helix meeting ASTM F1667 and having equal or greater withdrawal and lateral resistance strength may be substituted for the 6d nails. Staples having equal or greater withdrawal and lateral resistance strength may be substituted for the 6d nails.

Vapor Barrier — (Optional) — Nom 0.030 in. thick commercial asphalt saturated felt.

Floor Mat Materials* — (Optional) — Floor mat material loose laid over the subfloor. Refer to manufacturer's instructions regarding the minimum thickness of floor topping over each floor mat material.

GRASSWORX L L C — SC Types

Finish Flooring* — Min 3/4 in. thickness of any Floor Topping Mixture bearing the UL Classification Marking as to Fire Resistance. See Floor- and Roof-Topping Mixtures (CCOX) category for names of Classified Companies. Refer to the manufacturer's instructions accompanying the material and/or contact the manufacturer's technical support for specific mix design and minimum thickness recommended for use with eligible floor mat(s).

Floor Mat Reinforcement — (Optional) - Refer to manufacturer's instructions regarding minimum thickness of floor topping for use with floor mat reinforcement.

Metal Lath — (Optional) — Expanded steel diamond mesh, 2.5 lb / sq yd loose laid over floor mat material.

Fiberglass Mesh Reinforcement — (Optional) — Coated non-woven glass fiber mesh grid loose laid over floor mat material.

System No. 26

Subflooring – Building Units* — Nom 3/4 in. thick, ship-lap or tongue-in-groove edge detail. Long dimension of boards to be perpendicular to trusses with end joints staggered a min of 4 ft. and centered over the trusses. Boards secured to trusses with #8 x 2 in. long screws or 2 in. long by 0.113 in. ring shank nails spaced a max of 12 in. OC in the field and 8 in. OC along butt ends. Fasteners located 1/2 in. from butt edges and 2 in. from long edges of the board. When Finish Floor (see below) is not used, must be used with Item 7).

AMERIFORM L L C — Type Nocom

Finish floor – (Optional) - Min 1/2 in. thick, supplied in 4 ft by 8 ft panels, installed perpendicular or parallel to trusses with panel edges offset a min of 24 in. with adjacent sub-floor joints. Panels secured to subfloor with construction adhesive and corrosion resistant fasteners spaced a max of 12 in. OC. around perimeter and in the field of the panel. Fasteners located 1/2 in. at butt edges and 2 in. from long edge of the boards.

MULTI-PANELS – Type M4 Panel

System No. 27

Subflooring Min 23/32 in. thick T & G wood structural panels, min grade "Underlayment" or "Single-Floor". Face grain of plywood or strength axis of panels to be perpendicular to the trusses with end joints staggered 4 ft. Panels secured to trusses with construction adhesive and No. 6d ringed shank nails spaced 12 in. OC along each truss. TetraGRIP™ nails measuring 2-3/8 in. long, 0.113 in. diameter, 0.272 in. round head, and helically threaded shank with barbed features on the helix meeting ASTM F1667 and having equal or greater withdrawal and lateral resistance strength may be substituted for the 6d nails. Staples having equal or greater withdrawal and lateral resistance strength may be substituted for the 6d nails.

Finish Floor – Building Units* - (Optional) - Min 1/2 in. thick, supplied in 4 ft by 8 ft panels, installed perpendicular or parallel to trusses with panel edges offset a min of 24 in. with adjacent sub-floor joints. Panels secured to subfloor with construction adhesive and corrosion resistant fasteners spaced a max of 12 in. OC. around perimeter and in the field of the panel. Fasteners located 1/2 in. at butt edges and 2 in. from long edges of the board.

MULTI-PANELS – Type M4 Panel

System No. 28

Subflooring — Min 23/32 in. thick T & G wood structural panels, min grade "Underlayment" or "Single-Floor". Face grain of plywood or strength axis of panels to be perpendicular to the trusses with end joints staggered 4 ft. Panels secured to trusses with construction adhesive and No. 6d ringed shank nails spaced 12 in. OC along each truss. TetraGRIP™ nails measuring 2-3/8 in. long, 0.113 in. diameter, 0.272 in. round head, and helically threaded shank with barbed features on the helix meeting ASTM F1667 and having equal or greater withdrawal and lateral resistance strength may be substituted for the 6d nails. Staples having equal or greater withdrawal and lateral resistance strength may be substituted for the 6d nails.

Finish Flooring - Floor Topping Mixture* — Min 3/4 in. thickness of floor topping mixture having a min compressive strength of 900 psi. Refer to manufacturer's instructions accompanying the material for specific mix design.

TECNODRY SA DE CV – Type SURFACE GYP

2. **Trusses** — Parallel chord trusses, spaced a max 24 in. OC, fabricated from nom 2 by 4 in. lumber with lumber oriented vertically or horizontally. Min truss depth is 12 in. when item 9 is not employed. Min truss depth is 18 in. when item 9 is employed. Truss members secured together with min No. 20 MSG galv steel truss plates. Plates have 5/16 in. long teeth projecting perpendicular to the plane of the plate. The teeth are in pairs facing each other (made by the same punch), forming a split-tooth-type plate. Each tooth has a chisel point on its outside edge. These points are diagonally opposite each other for each pair. The top half of each tooth has a twist for stiffness. The pairs are repeated on approx 7/8 in. centers with four rows of teeth per in. of plate width.

3. **Furring Channels** — Hat channels, 7/8 in. deep by 2-9/16 in. or 2-11/16 in. or 2-23/32 in. wide at the base and 1-7/16 in. wide at the face, formed from No. 25 ga galv steel, spaced 24 in. OC perpendicular to trusses. Channels secured to trusses with double strand of No. 18 SWG galv steel wire spaced 48 in. OC. Ends of adjoining channels overlapped 6 in. and tied together with double strand of No. 18 SWG galv steel wire near each end of overlap. Two furring channels used at end joints of gypsum board (Item 4), each extending a min of 6 in. beyond both side edges of the board.

3A. **Resilient Channels** — (Not Shown) — As an alternate to Item 3, resilient channel formed from No. 26 MSG galv steel, spaced 16 in. OC perpendicular to trusses. Channels secured to each truss with 1-1/4 in. long No. 6 Type S bugle head steel screw. Channels overlapped at splices 4 in. Two resilient channels used at end joints of gypsum board (Item 4), each extending a min of 6 in. beyond both side edges of the board.

3B. **Steel Framing Members*** — (Optional)— Used as an alternate method to attach furring channels to trusses (Item 2). Clips spaced 48 in. OC. RSIC-1 and RSIC-1 (2.75) clips secured to the bottom chord of alternating trusses with No. 8 x 2-1/2 in. coarse drywall screw through the center grommet. RSIC-V and RSIC-V (2.75) clips secured to the bottom chord of alternating trusses with No. 8 x 1-1/2 in. coarse drywall screw through the center hole. Furring channels are friction fitted into clips. RSIC-1 and RSIC-V clips for use with 2-9/16 in. wide furring channels. RSIC-1 (2.75) and RSIC-V (2.75) clips for use with 2-23/32 in. wide furring channels. Adjoining channels are overlapped as described in Item 3. As an alternate, ends of adjoining channels may be overlapped 6 in. and secured together with two min 7/16 in. long No. 6 self-tapping framing screws, at the midpoint of the overlap, with one screw on each flange of the channel. Additional clips required to hold furring channel that supports the gypsum board butt joints, as described in Item 4. When Fiber, Sprayed (Item 6) is used, furring channel spacing reduced to 16 in. OC and two layers of nom 5/8 in. thick, 4 ft wide gypsum board shall be installed as described in Item 4.

PAC INTERNATIONAL L L C — Types RSIC-1, RSIC-V, RSIC-1 (2.75), RSIC-V (2.75)

3C. **Steel Framing Members*** — (Optional, Not Shown) — Used as an alternate method to attach furring channels to trusses. Clips spaced 48 in. OC., and secured to the bottom chord to alternating trusses with two No. 8 x 2-1/2 in. coarse drywall screws, one through the hole at each end of the clip. Furring channels are friction fitted into clips. Ends of adjoining channels overlapped 6 in. and tied together with double strand of No. 18 SWG galv steel wire near each end of overlap. Additional clips required to hold furring channel that supports the gypsum board butt joints, as described in Item 4. Two layers of gypsum board required as described in Item 4. Not evaluated for use with Item 6. When Item 3C is used and Batts and Blankets* are added per Section III Item 18 Blanket Insulation in the General Information of this Directory (BXUV), clips spaced 48 in. OC, furring channels spaced 16 in. OC max, 3-1/2 in. max. Batts and Blankets* secured to plywood subfloor with staples spaced 12 in. OC or to the trusses with 0.090 in. diam galv steel wires spaced 12 in. OC, and two layers of gypsum board required as described in Item 4A. When the Batts and Blankets* are draped over the furring channel/gypsum panel ceiling membrane, the clip spacing shall be reduced to 24 in. OC and secured to consecutive trusses, the furring channel spacing shall be reduced to 12 in. OC, and two layers of gypsum board required as described in Item 4A.

KINETICS NOISE CONTROL INC — Type Isomax.

3D. **Steel Framing Members*** — (Optional, Not Shown) — For Use with Item 7- Used as an alternate method to attach furring channels to trusses. Clips spaced 48 in. OC. and secured to the bottom chord to alternating trusses with one No. 8 x 2-1/2 in. coarse

drywall screw through the center hole. Furring channels are friction fitted into clips. Ends of adjoining channels overlapped 6 in. and tied together with double strand of No. 18 SWG galv steel wire near each end of overlap. Additional clips required to hold furring channel that supports the gypsum board butt joints, as described in Item 4. Not evaluated for use with Item 6.

PLITEQ INC — Type Genie Clip

3E. Steel Framing Members* — (Optional, Not Shown) — For use with Item 7B - Used as an alternate method to attach furring channels to trusses. Clips spaced at 48" OC and secured to the bottom of the trusses with one 2 in. Coarse Drywall Screw with 1 in. diam. washer through the center hole. Furring channels are then friction fitted into clips. Ends of channels are overlapped 6 in. and tied together with double strand of No. 18 SWG galv steel wire. Additional clips are required to hold the Gypsum Butt joints as described in item 4. Not evaluated for use with Item 6.

STUDCO BUILDING SYSTEMS — RESILMOUNT Sound Isolation Clips - Type A237 or A237R

3F. Resilient Channels — For use with Item 4B and 7A - Resilient channels, formed from No. 25 MSG galv steel and shaped as shown, spaced 12 in. OC perpendicular to joist. Channels overlapped 4 in. at splices and secured to each joist with 1-1/4 in. Type S screws. Min end clearance of channels to wall to be 1/2 in. Additional resilient channels positioned so as to coincide with end joints of gypsum board.

3G. Resilient Channels — For Use With Item 4C and 7C. Formed from min 25 MSG galv steel installed perpendicular to trusses and spaced 16 in. OC. Channels secured to each truss with 1-5/8 in. long Type S bugle head steel screws. Channels overlapped 4 in. at splices. Two channels, spaced 6 in. OC, oriented opposite each gypsum panel end joint. Additional channels shall extend min 6 in. beyond each side edge of panel. Insulation, Item 7C is applied over the resilient channel/gypsum panel ceiling membrane.

3H. Steel Framing Members* — (Optional, Not Shown) — Used as an alternate method to attach furring channels to trusses. Clips spaced at 48" OC and secured to the bottom of the trusses with one 2-1/2 in. Coarse Drywall Screw with 1 in. diam. washer through the center hole. Furring channels are then friction fitted into clips. Ends of channels are overlapped 6 in. and tied together with double strand of No. 18 SWG galv steel wire. Additional clips are required to hold the Gypsum Butt joints as described in item 4. Not evaluated for use with Item 6.

REGUPOL AMERICA — Type SonusClip

3I. Steel Framing Members — (Not Shown) — For use with Items 4C and 7F, As an alternate to Item 3, main runners, cross tees, cross channels and wall angle as listed below.

a. **Main Runners** — Nom 10 or 12 ft long, 15/16 in. or 1-1/2 in. wide face, spaced 4 ft. OC. Main runners suspended by min 12 SWG galv. steel hanger wires spaced 48 in. OC. Hanger wires to be located adjacent to main runner/cross tee intersections. Hanger wires wrapped and twist-tied on 16d nails driven in to side of trusses at least 5 in. above the bottom face.

b. **Cross Tees or Channels** — Nom 4 ft long cross tees, with 15/16 in. or 1-1/2 in. wide face, or nom 4 ft long cross channels, with 1-1/2 in. wide face, spaced 16 in. OC, installed perpendicular to the main runners. Additional cross tees or channels used 8 in. from each side of butted gypsum board end joints. The cross tees or channels may be riveted or screw-attached to the wall angle or channel to facilitate the ceiling installation.

c. **Wall Angle or Channel** — Painted or galv. steel angle with 1 in. legs or channel with 1 in. legs, 1-9/16 in. deep attached to walls at perimeter of ceiling with fasteners 16 in. OC. To support steel framing member ends and for screw-attachment of the gypsum panel.

USG INTERIORS LLC — Type DGL or RX

3J. Steel Framing Members* — (Optional, Not Shown) — Used to attach resilient channels (Item 3A) to trusses (Item 2). Clips spaced 48 in. OC on adjacent trusses, and secured to trusses with one No. 8 x 2-1/2 in. coarse drywall screw through center grommet hole. Channels secured to clips with one #10 x 1/2 in. pan-head self-drilling screw. Ends of adjoining channels overlapped 6 in. and secured together with two #8 15 x 1/2 in. Philips Modified Truss screws spaced 2-1/2 in. from the center of the overlap. Gypsum board butt joints require additional resilient channels spaced 1-1/2 in. from the butt joint on either side. One edge of the extra channels will extend to an adjacent truss where it is secured with a clip.

KEENE BUILDING PRODUCTS CO INC — Type RC+ Assurance Clip

3K. Resilient Channels — For use with items 3L, 4F, and 7G — Formed from min 26 MSG galv steel installed perpendicular to trusses. When Item 7G is draped over channels, channels spaced a maximum 12 in. OC. Channels secured to each truss as described in Item 3L.

Channel ends butted and centered under the joists and attached to the joists with one screw at each end. Additional resilient channels positioned so as to coincide with end joints of gypsum board as shown in the above illustration. Additional channels shall extend min 3 in. beyond each side edge of board.

3L. Steel Framing Members* — (Optional, Not Shown) — Used as an alternate method to attach resilient channels to joists (Item 2). For use with items 3K, 4F and 7G. A resilient sound isolation accessory shall be used at each attachment point of the resilient channels and spaced max 24 in. O.C. Channel ends butted and centered under the joists and attached to the joists with one accessory at each end. Additional accessories used to hold resilient channels that support the gypsum board end joints, as described in Item 3K. The accessory envelops the mounting edge of the resilient channel. The accessory and resilient channel are fastened to the joists with the screws supplied with the accessory and per the accessory manufacturer's installation instructions.

PAC INTERNATIONAL L L C — Types RC-1 Boost

3M. Steel Framing Members* — (Optional, Not Shown) — As an alternate to Item 3.

a. **Furring Channels** — Formed of No. 25 MSG galv steel, nominal 2-1/2 in. wide by 7/8 in. deep, spaced 24 in. OC, perpendicular to trusses. Channels secured to Cold Rolled Channels at every intersection with a 3/4 in. TEK screw through each furring channel leg. Ends of adjoining channels overlapped 12 in. and fastened together with two double strand No. 18 SWG galv steel wire ties, one at each end of overlap, or with two 3/4 in. TEK screws in each leg of the overlap section. Two furring channels used at end joints of gypsum board (Item 4), each extending a min of 6 in. beyond both side edges of the board.

b. **Cold Rolled Channels** — 1-1/2 in. by 1/2 in., formed from No. 16 ga. galv steel, positioned vertically and parallel to trusses, friction-fitted into the channel caddy on the Steel Framing Members (Item 3Md) and secured with two 3/4 in. TEK screws. Adjoining lengths of cold rolled channels lapped min. 12 in. and secured along bottom legs with four 3/4 in. TEK screws and wire-tied together with two double strand 18 SWG galv steel wire ties, one at each end of overlap.

c. **Blocking** — Where truss design does not permit direct, full contact of the hanger bracket, a piece of nominal 2 by 4 in. lumber (blocking), min. 12 in. long to permit full contact of the hanger bracket, to be secured vertically to the side of the trusses at the top and bottom of the blocking at each Steel Framing Member (Item 3Md) location with 16d nails or minimum 2-1/2 in. screws.

d. **Steel Framing Members*** — Spaced 48 in. OC. max along truss, and secured to the truss on alternating trusses with two, #10 x 1-1/2 in. screws through mounting holes on the hanger bracket.

PAC INTERNATIONAL L L C — Type RSIC-SI-CRC EZ Clip

3N. Steel Framing Members* — (Optional, Not Shown) — As an alternate to Item 3.

a. **Furring Channels** — Formed of No. 25 MSG galv steel, nominal 2-1/2 in. wide by 7/8 in. deep, spaced 24 in. OC perpendicular to trusses and friction fit into Steel Framing Members (Item 3Nc). Ends of adjoining channels overlapped 6 in. and tied together with double strand of No. 18 SWG galv steel wire near each end of overlap or with two TEK screws along each leg of the 6 in. overlap. Two furring channels used at end joints of gypsum board (Item 4). Butt joint channels held in place by strong back channels placed upside down, on top of, and running perpendicular to primary furring channels, extending 6 in. longer than length of gypsum side joint. Strong back channels spaced maximum 48 in. OC. Strong back channels secured to every intersection of primary furring channels with four 7/16 in. pan head screws, two along each of the legs at intersections. Butt joint channels run perpendicular to strong back channels and shall be minimum 6 in. longer than length of joint, secured to strong back channels with 7/16 in. pan head screws, two along each of the legs at intersection with strong back channels.

b. **Blocking** — Where truss design does not permit direct, full contact of the hanger bracket, a piece of nominal 2 by 4 in. lumber (blocking), min. 12 in. long to permit full contact of the hanger bracket, to be secured vertically to the side of the trusses at the top and bottom of the blocking at each Steel Framing Member (Item 3Nc) location with 16d nails or minimum 2-1/2 in. screws.

c. **Steel Framing Members*** — Used to attach furring channels (Item 3Na) to trusses. Clips spaced 48 in. OC and secured along truss webs at each furring channel intersection with min. 3/4 in. long self-drilling #10 x 1-1/2 in. screws through each of the provided hole locations. Furring channels are friction fitted into clips.

PAC INTERNATIONAL L L C — Type RSIC-S1-1 Ultra

3O. Resilient Channels — For Use With Item 4G and 7C. Formed from min 25 MSG galv steel installed perpendicular to trusses and spaced 16 in. OC. Channels secured to each truss with 1-1/4 in. long Type S bugle head steel screws. Channels overlapped 4 in. at

splices. Two channels, spaced 6 in. OC, oriented opposite each gypsum panel end joint. Additional channels shall extend min 6 in. beyond each side edge of panel. Insulation, Item 7C is applied over the resilient channel/gypsum panel ceiling membrane.

3P. **Steel Framing Members*** — (Optional, Not Shown, As an alternate to Item 3) — Furring channels and Steel Framing Members as described below:

A. **Furring Channels** — Formed of No. 25 MSG galv steel. 2-23/32 in. wide by 7/8 in., spaced 24 in. OC max perpendicular to trusses. Channels secured to trusses as described in Item 3Pb. Ends of adjoining channels are overlapped 6 in. and tied together with double strand of No. 18 SWG galv steel wire near each end of overlap. As an alternate, ends of adjoining channels may be overlapped 6 in. and secured together with two self-tapping #6 framing screws, min. 7/16 in. long at the midpoint of the overlap, with one screw on each flange of the channel. Additional clips required to hold furring channel that supports the wallboard butt joints, as described in Item 4.

B. **Steel Framing Members*** — Used to attach furring channels (Item 3Pa) to trusses (Item 2). Clips spaced 48 in. OC max with No. 8 x 2-1/2 in. course drywall screw through the center grommet. Furring channels are friction fitted into clips.

CLARKDIETRICH BUILDING SYSTEMS — Type ClarkDietrich Sound Clips

3Q. **Steel Framing Members*** — (Optional, Not Shown) — Used as an alternate method to attach resilient channels (items 3 and 3G) to joists (Item 2). For use with items 3K, 4F and 7G. A resilient sound isolation accessory shall be used at each attachment point of the resilient channels and spaced max 24 in. O.C. Channel ends butted and centered under the joists and attached to the joists with one accessory at each end. Additional accessories used to hold resilient channels that support the gypsum board end joints, as described in Item 3K. The accessory envelops the mounting edge of the resilient channel. The accessory and resilient channel are fastened to the joists with the 2in. screws supplied with the accessory and per the accessory manufacturer's installation instructions.

PAC INTERNATIONAL L L C — Types RC-1 Boost

3R. **Steel Framing Members*** — (Optional) — As an alternate to Item 3G — Used as an alternate method to attach furring channels to trusses (Item 2). Clips spaced 48 in. OC. RSIC-1 and RSIC-1 (2.75) clips secured to the bottom chord of alternating trusses with No. 8 x 2-1/2 in. coarse drywall screw through the center grommet. RSIC-1 and RSIC-V clips for use with 2-9/16 in. wide furring channels. RSIC-1 (2.75) clips for use with 2-23/32 in. wide furring channels. Adjoining channels are overlapped as described in Item 3. As an alternate, ends of adjoining channels may be overlapped 6 in. and secured together with two min 7/16 in. long No. 6 self-tapping framing screws, at the midpoint of the overlap, with one screw on each flange of the channel. Additional clips required to hold furring channel that supports the gypsum board butt joints, as described in Item 4. When Fiber, Sprayed (Item 6) is used, furring channel spacing reduced to 16 in. OC and two layers of nom 5/8 in. thick, 4 ft wide gypsum board shall be installed as described in Item 4.

PAC INTERNATIONAL L L C — Types RSIC-1, RSIC-1 (2.75), RSIC-SI-X.

3S. **Steel Framing Members*** — (Optional, Not Shown) — As an alternate to Item 3G.

a. **Furring Channels** — Formed of No. 25 MSG galv steel, nominal 2-1/2 in. wide by 7/8 in. deep, spaced 24 in. OC, perpendicular to trusses. Channels secured to Cold Rolled Channels at every intersection with a 3/4 in. TEK screw through each furring channel leg. Ends of adjoining channels overlapped 12 in. and fastened together with two double strand No. 18 SWG galv steel wire ties, one at each end of overlap, or with two 3/4 in. TEK screws in each leg of the overlap section. Two furring channels used at end joints of gypsum board (Item 4), each extending a min of 6 in. beyond both side edges of the board.

b. **Cold Rolled Channels** — 1-1/2 in. by 1/2 in., formed from No. 16 ga. galv steel, positioned vertically and parallel to trusses, friction-fitted into the channel caddy on the Steel Framing Members (Item 3Md) and secured with two 3/4 in. TEK screws. Adjoining lengths of cold rolled channels lapped min. 12 in. and secured along bottom legs with four 3/4 in. TEK screws and wire-tied together with two double strand 18 SWG galv steel wire ties, one at each end of overlap.

c. **Blocking** — Where truss design does not permit direct, full contact of the hanger bracket, a piece of nominal 2 by 4 in. lumber (blocking), min. 12 in. long to permit full contact of the hanger bracket, to be secured vertically to the side of the trusses at the top and bottom of the blocking at each Steel Framing Member (Item 3Md) location with 16d nails or minimum 2-1/2 in. screws.

d. **Steel Framing Members*** — Spaced 48 in. OC. max along truss, and secured to the truss on alternating trusses with two, #10 x 2in. screws through mounting holes on the hanger bracket.

PAC INTERNATIONAL L L C — Type RSIC-SI-CRC EZ Clip

3T. **Steel Framing Members*** — (Optional, Not Shown) — As an alternate to Item 3G.

a. **Furring Channels** — Formed of No. 25 MSG galv steel, nominal 2-1/2 in. wide by 7/8 in. deep, spaced 24 in. OC perpendicular to trusses and friction fit into Steel Framing Members (Item 3Nc). Ends of adjoining channels overlapped 6 in. and tied together with double strand of No. 18 SWG galv steel wire near each end of overlap or with two TEK screws along each leg of the 6 in. overlap. Two furring channels used at end joints of gypsum board (Item 4). Butt joint channels held in place by strong back channels placed upside down, on top of, and running perpendicular to primary furring channels, extending 6 in. longer than length of gypsum side joint. Strong back channels spaced maximum 48 in. OC. Strong back channels secured to every intersection of primary furring channels with four 7/16 in. pan head screws, two along each of the legs at intersections. Butt joint channels run perpendicular to strong back channels and shall be minimum 6 in. longer than length of joint, secured to strong back channels with 7/16 in. pan head screws, two along each of the legs at intersection with strong back channels.

b. **Blocking** — Where truss design does not permit direct, full contact of the hanger bracket, a piece of nominal 2 by 4 in. lumber (blocking), min. 12 in. long to permit full contact of the hanger bracket, to be secured vertically to the side of the trusses at the top and bottom of the blocking at each Steel Framing Member (Item 3Nc) location with 16d nails or minimum 2-1/2 in. screws.

c. **Steel Framing Members*** — Used to attach furring channels (Item 3Na) to trusses. Clips spaced 48 in. OC and secured along truss webs at each furring channel intersection with min. 3/4 in. long self-drilling #10 x 2in. screws through each of the provided hole locations. Furring channels are friction fitted into clips.

PAC INTERNATIONAL L L C — Type RSIC-S1-1 Ultra

3U. **Steel Framing Members*** — (Optional, Not Shown) — For Use with Item 7G- Used as an alternate method to attach furring channels to trusses. Clips spaced 48 in. OC. and secured to the bottom chord to alternating trusses with one No. 8 x 2-1/2 in. screw and washer through the center hole. Furring channels are friction fitted into clips. Ends of adjoining channels overlapped 6 in. and tied together with double strand of No. 18 SWG galv steel wire near each end of overlap or screw attached with two pan head screws on each leg of overlap. Additional clips required to hold furring channel that supports the gypsum board butt joints, as described in Item 4. Not evaluated for use with Item 6.

ISOTECH INDUSTRIES INC. — Type ISOWALL

4. **Gypsum Board*** — One layer of nom 5/8 in. thick, 4 ft wide gypsum board, installed with long dimension perpendicular to furring or resilient channels. Gypsum board secured with 1 in. long No. 6 Type S bugle head steel screws spaced 12 in. OC and located a min of 1-1/2 in. from side and end joints. End joints secured to both resilient channels as shown in the end joint detail. When **Steel Framing Members** (Item 3B and 3P) are used, one layer of nom 5/8 in. thick, 4 ft wide gypsum board is installed with long dimension perpendicular to furring channels. Gypsum board secured to furring channels with nom 1 in. long No. 6 Type S bugle head screws spaced 12 in. OC in the field of the board. Gypsum board butt joints shall be staggered 2 ft within the assembly, and shall occur between the main furring channels. At the gypsum board butt joints, each end of each gypsum board shall be supported by a single length of furring channel equal to the width of the gypsum board plus 6 in. on each end. The two furring channels at each butt joint shall be spaced approximately 3-1/2 in. OC, and be attached to the bottom chord of the truss with one clip at each end of the channel. Screw spacing along the gypsum board butt joint shall be 8 in. OC. When both **Steel Framing Members** (Item 3B) and **Fiber, Sprayed** (Items 6 or 6A) are used, furring channel spacing reduced to 16 in. OC and two layers of nom 5/8 in. thick, 4 ft wide gypsum board are installed with long dimension perpendicular to furring channels. Base layer secured to furring channels with nom 1 in. long No. 6 Type S bugle head screws spaced 12 in. OC in the field of the board. Gypsum board butt joints shall be staggered 2 ft within the assembly, and shall occur between the main furring channels. At the gypsum board butt joints, each end of each gypsum board shall be supported by a single length of furring channel equal to the width of the gypsum board plus 6 in. on each end. The two furring channels at each butt joint shall be spaced approximately 3-1/2 in. OC, and be attached to the bottom chord of the truss with one RSIC-1 clip at each end of the channel. Screw spacing along the gypsum board butt joint shall be 8 in. OC. Outer layer secured to furring channels using 1-5/8 in. long No. 6 Type S screws spaced 8 in. OC and 1-1/2 in. from the end joint. Butted end joints to be offset a min. of 8 in. from base layer end joints. Butted side joints of outer layer to be offset min. 18 in. from butted side joints of base layer. When **Steel Framing Members** (Item 3C) are used, two layers of nom 5/8 in. thick, 4 ft wide are installed with long dimensions perpendicular to furring channels. Base layer attached to the furring channels using 1 in. long No. 6 Type S bugle-head steel screws spaced 12 in. OC in the field of the board. Butted end joints shall be staggered min 2 ft. within the assembly, and occur midway between the continuous furring channels. Each end of each gypsum board shall be supported by a single length of furring channel equal to the width of the gypsum board plus 6 in. on each end. The two furring channels shall be spaced approximately 4 in. OC, and be attached to underside of the truss with one Isomax clip at each end of the channel. Screw spacing along the gypsum board butt joint shall be 8 in. OC. Outer layer attached to the furring channels using 1-5/8 in. long No. 6 Type S bugle-head steel screws spaced 12 in. OC in the field. The end of the outer layer boards at the butt joint shall be attached to the base layer boards with 1-5/8 in. long Type G screws spaced 8 in. OC and 1-1/2 in. from the end joint. Butted end joints to be offset a min of 8 in. from base layer end joints. Butted side joints of outer layer to be offset min 18 in. from butted side joints of base layer. When **Steel Framing Members** (Item 3D)

are used, one layer of nom 5/8 in. thick, 4 ft wide gypsum board is installed with long dimensions perpendicular to furring channels. Gypsum board secured to furring channels with nom 1 in. long No. 6 Type S bugle-head steel screws spaced 12 in. OC in the field of the board. Gypsum board butted end joints shall be staggered minimum 16 in. within the assembly. . At the gypsum board butt joints, each end of each gypsum board shall be supported by a single length of furring channel equal to the width of the gypsum board plus 6 in. on each end. These additional furring channels shall be attached to underside of the truss with Genie clips as described in Item 3D. Screw spacing along the gypsum board butt joint shall be 6 in. OC. When **Steel Framing Members** (Item 3E) are used, one layer of nom 5/8 in. thick, 4 ft wide gypsum board is installed with long dimensions perpendicular to furring channels. Gypsum board secured to furring channels with nom 1 in. long Type S bugle-head steel screws spaced 8 in. OC in the field of the board. Gypsum board butted end joints shall be staggered minimum 48 in. and centered over main furring channels. At the gypsum board butt joints, each end of each gypsum board shall be supported by a single length of furring channel equal to the width of the gypsum board plus 3 in. on each end. The two support furring channels shall be spaced approximately 3 in. in from joint. Screw spacing along the gypsum board butt joint and along both additional channels shall be 8 in. OC. Additional screws shall be placed in the adjacent section of gypsum board into the aforementioned 3 in. extension of the extra butt joint channels as well as into the main channel that runs between . Butt joint furring channels shall be attached with one RESILMOUNT Sound Isolation Clip at each end of the channel. When **Fiber, Sprayed** (Items 6 or 6A) is used, two layers of nom 5/8 in. thick, 4 ft wide gypsum board are installed with long dimensions perpendicular to furring channels. Base layer gypsum board secured with 1 in. long No. 6 Type S bugle head steel screws spaced 12 in. OC and located a min of 1-1/2 in. from side and end joints. End joints secured to both resilient channels as shown in the end joint detail. Outer layer gypsum board secured with 1-5/8 in. long No. 6 Type S bugle head steel screws spaced 12 in. OC and located a min of 1-1/2 in. from side and end joints. Outer layer shall be finished as described in Item 5. When **Foamed Plastic** insulation (Item 7E) is applied to the underside of the subflooring, screw spacing shall be reduced to 8 in. OC with minimum 1-1/4 in. long Type S screws to install gypsum to the resilient channels (Item 3A). Resilient channels (Item 3A) to be spaced maximum 12 in. OC. Butted end joints shall be staggered min. 2 ft within the assembly, and occur midway between the continuous furring channels. End joints secured to both resilient channels as shown in end joint detail.

When **Steel Framing Members** (Item 3E) are used, one layer of nom 5/8 in. thick, 4 ft wide gypsum board is installed with long dimensions perpendicular to furring channels. Gypsum board secured to furring channels with nom 1 in. long Type S bugle-head steel screws spaced 8 in. OC in the field of the board. Gypsum board butted end joints shall be staggered minimum 48 in. and centered over main furring channels. At the gypsum board butt joints, an additional single length of furring channel shall be installed and be spaced approximately 3 in. from the butt joint (6 in. from the continuous furring channels) to support the floating end of the gypsum board. Each of these shorter sections of furring channel shall extend one truss beyond the width of the gypsum panel and be attached to the adjacent trusses with one SonusClip at every truss involved with the butt joint.

When **Steel Framing Members*** (Item 3I) are used, one layer of 5/8 in. thick, 48 in. wide gypsum board, installed with long dimension perpendicular to cross channels with side joints centered along main runners. Gypsum board fastened to cross channels with 1 in. long No. 8 Type S bugle head steel screws located 1/2 in. from end joints and 1-3/4 in. from side joints and spaced 8 in. OC along the end joints and in the field. Panels fastened to cross tees with 1 in. long, Type S bugle-head screws spaced in the field and 8 in. OC along end joints. Panels fastened to main runners with 1 in. long, Type S bugle-head screws spaced midway between cross tees. Screws along sides and ends of panels spaced 3/8 to 1/2 in. from panel edge. Gypsum board sheets screw attached to leg of wall angle with 1 in. long No. 8 Type S bugle head steel screws spaced 12 in. OC. End joints of panels shall be staggered with spacing between joints on adjacent panels not less than 4 ft OC.

When **Steel Framing Members** (Item 3J) are used, one layer of nom 5/8 in. thick, 4 ft wide gypsum board is installed with long dimensions perpendicular to resilient channels. Gypsum board secured to resilient channels with nom 1 in. long Type S bugle-head steel screws spaced 8 in. OC in the field of the board and located 3/4 in. from side joints and 1-1/2 in. from end joints. Gypsum board joints are to be staggered by a minimum of 24 in.

When **Steel Framing Members** (Item 3M) are used, nom 5/8 in. thick, 4 ft wide gypsum board, installed as described in Item 4. Adjacent butt joints staggered minimum 48 in. OC.

When **Steel Framing Members** (Item 3N) are used, nom 5/8 in. thick, 4 ft wide gypsum board, installed as described in Item 4. Butt joints staggered minimum 24 in. OC.

When **Steel Framing Members** (Item 3U) are used, nom 5/8 in. thick, 4 ft wide gypsum board, installed as described in Item 4. Butt joints staggered minimum 48 in. OC.

AMERICAN GYPSUM CO — Type AG-C

CERTAINTED GYPSUM INC — Type C

CGC INC — Types C, IP-X2, IPC-AR

CERTAINTED GYPSUM INC — Type LGFC-C/A

GEORGIA-PACIFIC GYPSUM L L C — Types 5, DAPC, TG-C

NATIONAL GYPSUM CO — Types eXP-C, FSK-C, FSW-C, FSW-G

PABCO BUILDING PRODUCTS L L C, DBA PABCO GYPSUM — Type C

THAI GYPSUM PRODUCTS PCL — Type C

UNITED STATES GYPSUM CO — Types C, IP-X2, IPC-AR

USG BORAL DRYWALL SFZ LLC — Type C

USG MEXICO S A DE C V — Types C, IP-X2, IPC-AR

4A. **Gypsum Board** — For use when Item 3C is used and **Batts and Blankets*** are secured to the plywood subfloor, to the trusses or draped over the furring channel/gypsum panel ceiling membrane as described in Item 3C. For method of gypsum board installation, see Item 4.

CGC INC — Types C, IP-X2, IPC-AR

UNITED STATES GYPSUM CO — Types C, IP-X2, IPC-AR

USG BORAL DRYWALL SFZ LLC — Type C

USG MEXICO S A DE C V — Types C, IP-X2, IPC-AR

4B. **Gypsum Board*** — For use when **Batts and Blankets*** (Item 7A) and Resilient Channels (Item 3F) are used. Nom 5/8 in. thick, 4 ft wide gypsum board installed with long dimension perpendicular to resilient channels. Nom 1 in. long No. Type S bugle head screws are driven through channel spaced 8 in. OC. End joints of gypsum board similarly fastened to additional resilient channels positioned at end joint locations.

AMERICAN GYPSUM CO — Type AG-C.

CERTAINTED GYPSUM INC — Type LGFC-C/A

PABCO BUILDING PRODUCTS L L C, DBA PABCO GYPSUM — Type C

4C. **Gypsum Board*** — For use with Items 3G and 7C or 3I and 7F, or 3I and 7C. Nom 5/8 in. thick, 48 in. wide gypsum panels installed with long dimension perpendicular to resilient channels. Gypsum panels secured with 1 in. long Type S bugle head steel screws spaced 8 in. OC and located a min of 1/2 in. from side joints and 3 in. from the end joints. Finish Rating with this ceiling system is 20 min.

CGC INC — Type ULIX

UNITED STATES GYPSUM CO — Type ULIX

4D. **Gypsum Board*** — For use when Flooring System (Item 1) consists of both System No. 1 and min 15/32 in. plywood, min grade "Underlayment" or "Sturd-I-Floor" with T & G edges and conforming with PS1-83 specifications, or min 3/4 in. thickness of any Floor Topping Mixture (CCOX) bearing the UL Classification Marking as to Fire Resistance, min Truss depth (Item 2) is 18 in. and Batts and Blankets (Item 7D) and Resilient Channels (Item 3A) are used. One layer of nom 5/8 in. thick, 48 in. wide gypsum board installed with

long dimension perpendicular to resilient channels. Gypsum board secured with 1 in. long Type S bugle head steel screws. Screws spaced 1 in. from side joints, and 12 in. OC in the rest of the field. Screws spaced 1-1/2 in. from the end joints. End joints secured to both resilient channels as shown in end joint detail. When batt insulation (Item 7D) is draped over the resilient channel/gypsum board ceiling membrane, the resilient channel (Item 3A) spacing shall be reduced to 12 in. OC., and gypsum board screws spaced 1 in. from side joints, and 8 in. OC in the rest of the field. For use only with Ceiling Damper described in Item 9R.

PANEL REY S A — Type PRC2

4F. Gypsum Board* — For use with Items 3K, 3L, and 7G— One layer of nom 5/8 in. thick, 4 ft wide gypsum board is installed with long dimensions perpendicular to resilient channels. Gypsum board secured to resilient channels with min nom 1 in. long Type S bugle-head steel screws spaced 8 in. OC in the field of the board and located 3/4 in. from side joints and 1-1/2 in. from end joints. Gypsum board butt joints are to be staggered by a minimum of 24 in.

PABCO BUILDING PRODUCTS L L C, DBA PABCO GYPSUM — Type C

4G. Gypsum Board* — For use with Items 3G and 7C. Nom 5/8 in. thick, 48 in. wide gypsum panels installed with long dimension perpendicular to resilient channels. Gypsum panels secured with 1 in. long Type S bugle head steel screws spaced 8 in. OC and located a min of 1/2 in. from side joints and 3 in. from the end joints.

AMERICAN GYPSUM CO — Type AG-C.

5. Finishing System — (Not Shown) — Vinyl, dry or premixed joint compound, applied in two coats to joints and screw-heads. Nom 2 in. wide paper tape embedded in first layer of compound over all joints. As an alternate, nom 3/32 in. thick veneer plaster may be applied to the entire surface of gypsum board.

6. Fiber, Sprayed* — (Dry Dense Packed 100% Borate Formulation) — (Not Shown, Optional) — The fiber is applied without water or adhesive at a nominal dry density of 3.5 lb/ft³, in accordance with the application instructions supplied with the product. When Item 6 (Fiber, Sprayed, Dry Dense Packed) is used, Furring Channels (Item 3F) or Resilient Channels (Item 3A) spacing shall be reduced to 12 in. OC. When Item 6 (Fiber, Sprayed, Dry Dense Packed) is used, two layers of gypsum board required as described in Item 4. Not evaluated for use with Item 3C.

APPLEGATE GREENFIBER ACQUISITION LLC — Insulmax and SANCTUARY to be used with dry application only.

6A. Fiber, Sprayed* — (Loose Fill 100% Borate Formulation) — (Not Shown, Optional) — The finished rating when Fiber, Sprayed is used has not been determined. The fiber is applied without water or adhesive at a minimum dry density of 0.5 lb/ft³ and at a max thickness of 3-1/2 in., in accordance with the application instructions supplied with the product. When Item 6A (Fiber, Sprayed, Loose Fill) is used, Furring Channels (Item 3F) or Resilient Channels (Item 3A) spacing shall be reduced to 12 in. OC. When Item 6A (Fiber Sprayed, Loose Fill) is used, two layers of gypsum board required as described in Item 4. Not evaluated for use with Item 3C.

APPLEGATE GREENFIBER ACQUISITION LLC — Insulmax & SANCTUARY to be used with dry application only.

7. Batts and Blankets* — (Not Shown) — For use with Item 3D — Nom 3 in. thick mineral wool insulation held suspended in the concealed space with 0.090 in. diam galv steel wires attached to the wood trusses at 18 in. OC.

7A. Batts and Blankets* — For Use With Items 3F and 4B — Glass fiber insulation bearing the UL Classification Marking as to Surface Burning Characteristics and/or Fire Resistance having a min. density of 0.5 pcf, draped over the resilient channel/gypsum panel ceiling membrane. No limit on overall thickness.

7B. Batts and Blankets* — (Not Shown) — For use with Item 3E — Nom 3-1/2 in. thick, min. 2 pcf fiber glass insulation held suspended in the concealed space with nominal 0.090 in. diam galv steel wires attached to the wood trusses at nominally 16 in. OC.

7C. Batts and Blankets* or Fiber, Sprayed* — For Use with Item 4C (Not Shown) — Min. 3-1/2 in thick with no limit on maximum thickness fitted in the concealed space, draped over the resilient channel (Item 3G)/gypsum board (Item 4C or 4G) ceiling membrane.

7D. Batts and Blankets* — For Use With Item 4D — Insulation may be secured to plywood subfloor with staples spaced 12 in. OC or to the trusses with 0.090 in. diam galv steel wires spaced 12 in. OC. Insulation may alternatively be draped over the resilient channels and gypsum board ceiling membrane, and the resilient channels and gypsum board attachment shall be modified as specified in Item 4D. Any glass fiber insulation bearing the UL Classification Marking for Surface Burning Characteristics and/or Fire Resistance, and having a min density of 0.5 pcf and max thickness of 3-1/2 in. may be used.

7E. Foamed Plastic* — (As alternate to Item 6 and 6A, Not Shown) — Spray foam insulation applied directly to the underside of the plywood subflooring. Spray foam insulation installed to a maximum thickness of 10 in. at a nominal 0.5 lb/ft³ or 2.0 lb/ft³ density, depending on the product installed. Spray foam insulation is limited to use with minimum 18 in. deep trusses (Item 2). When spray foam insulation is installed, resilient channels (Item 3A) shall be installed maximum 12 in. OC, with channels adjacent to butt joints of gypsum board (Item 4) spaced maximum 3 in. away from gypsum butt joints. Gypsum board (Item 4) to be installed using minimum 1-1/4 in. long Type S screws, spaced maximum 8 in. OC, and butted end joints shall be staggered min. 2 ft within the assembly, and occur midway between the continuous furring channels. If used with a ceiling damper (Item 9) in the concealed space, minimum 1 in. clearance to be maintained between damper housing and spray foam insulation. Not evaluated for use with Items 3, 3B through 3F, 3G, 6, 6A, 7 through 7D. Not evaluated with Flooring System (Item 1) Configuration No. 1.

BASF CORP — Enertite® NM, Enertite® G, FE178®, Spraytite® 178, Spraytite® 81206, Walltite® 200, Walltite® US, Walltite® US-N, Walltite® HP+, Walltite® MAX, Walltite® v.5, Walltite® LWP, Walltite® Plus and Enertite® Max.

7F. Batts and Blankets* — (Not Shown) For Use with Item 3I and 4C — Glass fiber or mineral wool insulation bearing the UL Classification Marking as to Surface Burning Characteristics and/or Fire Resistance. There is no limit in the overall thickness of insulation, and the insulation can be secured against the subflooring, held suspended in the concealed space or draped over the Steel Framing Members and gypsum panel membrane.

7G. Batts and Blankets* — (Not Shown) For Use with Item 3L, 3K, 3U, and 4F — Glass fiber or mineral wool insulation bearing the UL Classification Marking as to Surface Burning Characteristics and/or Fire Resistance. There is no limit in the overall thickness of insulation, and the insulation can be secured against the subflooring, held suspended in the concealed space or draped over the Steel Framing Members and gypsum panel membrane.

7H. Foamed Plastic* — (As alternate to Items 6 and 7) — Spray foam insulation applied directly to the underside of the plywood subflooring. Spray foam insulation installed to a maximum thickness of 11 in. at a nominal 1.0 lb/ft³ - 2.5 lb/ft³ density, while maintaining a minimum 7 in. clearance between the spray foam insulation and the gypsum board (Item 4). Spray foam insulation is limited for use with minimum 18 in. deep trusses (Item 2). When spray foam insulation is installed, resilient channels (Item 3A) shall be installed maximum 12 in. OC, with channels adjacent to butt joints of gypsum board spaced maximum 3 in. away from gypsum butt joints. Gypsum board to be installed using minimum 1-1/4 in. long Type S screws, spaced maximum 8 in. OC, and butted end joints shall be staggered min. 2 ft within the assembly, and occur midway between the continuous furring channels. If used with a ceiling damper (Item 9) in the concealed space, no clearance is necessary between damper housing and spray foam insulation. Only for use with item 3A not evaluated for use with alternates to item 3A.

CARLISLE SPRAY FOAM INSULATION — Types SealTite Pro Closed Cell (CC), SealTite Pro Open Cell (OC), SealTite Pro OCX, SealTite Pro No Trim 21, SealTite Pro One Zero, SealTite PRO HFO, Foamsulate Closed Cell, Foamsulate OCX, Foamsulate 70, Foamsulate HFO, and Foamsulate HFO 2.0.

7I. Batts and Blankets* — (Not Shown - Required as indicated with Flooring System No. 26) - Glass fiber insulation bearing the UL Classification Marking as to Surface Burning Characteristics and/or Fire Resistance. Min. 3-1/2 in. thick, 0.92 pcf density, draped over the resilient or furring channels and gypsum panel membrane. Resilient or furring channels to be spaced 12 in. OC with extra channels installed at butt joints as indicated above.

8. Air Duct* — (Optional) — Any UL Class 0 or Class 1 flexible air duct installed in accordance with the instructions provided by the damper manufacturer.

9. Ceiling Damper* — (Optional. To be used with Air Duct Item 8.) — For use with min. 18 in. deep trusses. Not for use with flooring system 1 or 17. Max. nom area shall be 349 sq in. Max. overall length and width shall not exceed 18-11/16 in. by 18-11/16 in. with max. 16 in. by 16 in. register opening. Aggregate damper openings shall not exceed 175 sq in. per 100 sq ft of ceiling area. Damper installed in accordance with the manufacturers installation instructions provided with the damper. An aluminum or steel grille (Item 10) shall be installed in accordance with installation instructions.

MIAMI TECH INC — Model Series RxCRD, RxCRDS or RxCRPD

9A. Alternate Ceiling Damper* — (Optional. To be used with Air Duct Item 8.) — For use with min. 18 in. deep trusses. Not for use with flooring system 1 or 17. Max damper assembly size nom 18 in. long by 18 in. wide and 4-1/4 in. high, or 8 in. diam. fabricated from galv steel. Aggregate damper openings shall not exceed 162 sq in. per 100 sq ft of ceiling area. Damper installed in accordance with the manufacturers installation instructions provided with the damper.

RUSKIN COMPANY — Model CFD7T, CFD7T-END-BT, CFD7T-90-BT, CFD7T-ST-BT, CFD7T-SB, CFD7T-R6-DB, CFD-7T-IB6 or CFDR7T

9B. Deleted.

9C. **Alternate Ceiling Damper*** — (Optional. To be used with Air Duct Item 8.) — For use with min. 18 in. deep trusses. Not for use with flooring system 1 or 17. Max 12 in. diameter damper with insulated register box assembly. The maximum size of the register box assembly is nom. 20 in. long by 20 in. wide and 4 in. high fabricated from galv steel. Aggregate area of the register opening(s) through the ceiling membrane shall not exceed 128 sq in. per 100 sq ft of ceiling area. Damper assembly installed in accordance with the manufacturers installation instructions.

AIRE TECHNOLOGIES INC — Series 57

9D. **Alternate Ceiling Damper*** — (Optional. To be used with Air Duct Item 8.) — For use with min. 18 in. deep trusses. Not for use with flooring system 1 or 17. Max 20 in. long by 16 in. wide by 4 in. high rectangular damper with duct board plenum box assembly. The maximum outer dimensions of the plenum box assembly are 23-1/2 in. long by 19-1/2 in. wide and 17 in. high fabricated from 6pcf, 1-1/2 to 2 in. thick Knauf Air Duct Board M*. Aggregate area of the register opening(s) through the ceiling membrane shall not exceed 160 sq in. per 100 sq ft ceiling area. Damper assembly installed in accordance with the manufacturers installation instructions.

AIRE TECHNOLOGIES INC — Series 58

9E. **Alternate Ceiling Damper*** — (Optional. To be used with Air Duct Item 8.) — For use with min. 18 in. deep trusses. Not for use with flooring system 1 or 17. Max 14 in. long by 14 in. wide by rectangular damper with 90° boot. The maximum size of damper/boot assembly is 14 in. long by 14 in. wide and 18 in. high fabricated from galv steel. The aggregate area of the register opening(s) through the ceiling membrane shall not exceed 98 sq in. per 100 sq ft ceiling area. Damper assembly installed in accordance with the manufacturers installation instructions.

AIRE TECHNOLOGIES INC — Models 50 w/ Boot, 50EA w/ Boot, 51 w/Boot, 50 w/ Box, 50EA w/ Box or 51 w/Box

9F. **Alternate Ceiling Damper*** — (Optional. To be used with Air Duct Item 8.) — For use with min 18 in. deep trusses Not for use with flooring system 1 or 17. Max plenum box size nom 19 in. long by 19 in. wide and 11-7/8 in. high fabricated from galv steel. Aggregate damper openings shall not exceed 128 sq in. per 100 sq ft of ceiling area. Damper installed in accordance with the manufacturers installation instructions provided with the damper.

LLOYD INDUSTRIES INC — Model CRD 50-BT, CRD 50-EA-BT, CRD 55-BT, CRD 55 EA-BT

UNITED ENERTECH CORP — Model C-S/R-WT-L, C-S/R-EA-L, C-S/R-BT, C-S/R-EA-BL

9G. **Alternate Ceiling Damper*** — (Optional. To be used with Air Duct Item 8). For use with min 18 in. deep trusses Not for use with flooring system 1 or 17. Max plenum box size nom 13 in. long by 13 in. wide and 11-7/8 in. high fabricated from galv steel. Aggregate damper openings shall not exceed 50 sq in. per 100 sq ft of ceiling area. Damper installed in accordance with the manufacturers installation instructions provided with the damper.

LLOYD INDUSTRIES INC — Model CRD 50-BT-6, CRD 50-EA-BT-6, CRD 55-BT-6, CRD 55 EA-BT-6

9H. **Alternate Ceiling Damper*** — (Optional. To be used with Air Duct Item 8). Ceiling damper & fan assembly for use with min 18 in. deep trusses. Not for use with flooring system 1 or 17. Max nom area shall be 103 sq in. with the length not to exceed 10-1/8 in. and the width not to exceed 10-1/8 in. Aggregate damper openings shall not exceed 52 sq in. per 100 sq ft of ceiling area. Damper shall be installed in combination with one of the fan models described in, and in accordance with, the manufacturer's installation instructions provided with the damper. A plastic grille (Item 10) shall be installed in accordance with installation instructions.

PANASONIC CORPORATION, PANASONIC CORPORATION OF NORTH AMERICA — Model PC-RD05C5

9I. **Alternate Ceiling Damper*** — (Optional. To be used with Air Duct Item 8). Ceiling damper & fan assembly for use with min 18 in. deep trusses. Not for use with flooring system 1 or 17. Max nom area shall be 113 sq in. with the length not to exceed 10-1/8 in. and the width not to exceed 11-1/8 in. Aggregate damper openings shall not exceed 57 sq in. per 100 sq ft of ceiling area. Damper shall be installed in combination with one of the fan models described in, and in accordance with, the manufacturer's installation instructions provided with the damper. A plastic grille (Item 10) shall be installed in accordance with installation instructions.

BROAN-NUTONE L L C — Model RDFUWT

9J. **Alternate Ceiling Damper*** — (Optional. To be used with Air Duct Item 8). Ceiling damper & fan assembly for use with min 18 in. deep trusses. Not for use with flooring system 1 or 17. Max nom area shall be 79 sq in. with the length not to exceed 10 in. and the width not to exceed 7-15/16 in. Aggregate damper openings shall not exceed 40 sq in. per 100 sq ft of ceiling area. Damper shall be installed in combination with one of the fan models described in, and in accordance with, the manufacturer's installation instructions provided with the damper. A metallic grille (Item 10) shall be installed in accordance with installation instructions.

BROAN-NUTONE L L C — Models RDJ1 and RDH

9K. **Alternate Ceiling Damper*** — (Optional. To be used with Air Duct Item 8). For use with min 18 in. deep trusses. Not for use with flooring system 1 or 17. Max plenum box size nom 19 in. long by 19 in. wide and 11-7/8 in. high fabricated from galv steel. Aggregate damper openings shall not exceed 128 sq in. per 100 sq ft of ceiling area. Damper installed in accordance with the manufacturers installation instructions provided with the damper.

METAL-FAB INC — Models MSCD-HC and MRCD-HC

9L. **Alternate Ceiling Damper*** — (Optional, To be used with Air Duct Item 8). Ceiling damper & fan assembly for use with min 18 in. deep trusses. Not for use with flooring system 1 or 17. Max nom area shall be 87 sq in. with the length not to exceed 9 in. and the width not to exceed 9-11/16 in. Aggregate damper openings shall not exceed 44 sq in. per 100 sq ft of ceiling area. Damper shall be installed in combination with one of the fan models described in, and in accordance with, the manufacturer's installation instructions provided with the damper. A plastic grille (Item 10) shall be installed in accordance with installation instructions.

BROAN-NUTONE L L C — Model RDMWT

9M. **Alternate Ceiling Damper*** — Ceiling damper & fan assembly for use with min 18 in. deep trusses. Max nom area shall be 87 sq in. with the length not to exceed 9 in. and the width not to exceed 9-11/16 in. Aggregate damper openings shall not exceed 44 sq in. per 100 sq ft of ceiling area. Damper shall be installed in combination with one of the fan models described in, and in accordance with, the manufacturer's installation instructions provided with the damper. A plastic grille (Item 10) shall be installed in accordance with installation instructions.

BROAN-NUTONE L L C — Model RDMWT2

9N. **Alternate Ceiling Damper*** — (Optional. To be used with Air Duct Item 8) — For use with min 18 in. deep trusses. Not for use with flooring system 1 or 17. Max nom 21 in. long by 18 in. wide, fabricated from galvanized steel. Plenum box max size nom 21 in. long by 18 in. wide by 14 in. high (inner dimension) fabricated from either galvanized steel or min 1 in. thick Listed Duct Board bearing the UL Listing Marking having a min R-Value of 4.3. Installed in accordance with the instructions provided by the manufacturer. Max damper openings not to exceed 180 sq in. per 100 sq ft of ceiling area.

GREENHECK FAN CORP — Model CRD-1WT

9O. **Alternate Ceiling Damper*** — (Optional. To be used with Air Duct Item 8) — For use with min 18 in. deep trusses. Not for use with flooring system 1 or 17. Max nom 12 in. long by 12 in. wide with an 8 in. diameter damper, fabricated from galvanized steel. Installed in accordance with the instructions provided by the manufacturer. Max damper openings not to exceed 72 sq in. per 100 sq ft of ceiling area.

GREENHECK FAN CORP — Model CRD-2WT

9P. **Alternate Ceiling Damper*** — For use with min 18 in. deep trusses. Not for use with flooring system 1 or 17. Max nom area shall be 324 sq in. with the length not to exceed 24 in. and the width not to exceed 20 in. Max height of damper shall be 14 in. Aggregate damper openings shall not exceed 162 sq in. per 100 sq ft of ceiling area. Damper installed in accordance with the manufacturers installation instructions provided with the damper. A steel grille (Item 10) shall be installed in accordance with installation instructions.

C&S AIR PRODUCTS — Model RD-521

POTTORFF — Model CFD-521

9Q. **Alternate Ceiling Damper*** — For use with min 18 in. deep trusses. Not for use with flooring system 1 or 17. Max nom area shall be 196 sq in. with the length not to exceed 26 in. and the width not to exceed 14 in. Max height of damper shall be 7 in. Aggregate damper openings shall not exceed 98 sq in. per 100 sq ft of ceiling area. Damper installed in accordance with the manufacturers installation instructions provided with the damper. A steel grille (Item 10) not to exceed 144 in.² shall be installed in accordance with installation instructions.

C&S AIR PRODUCTS — Model RD-521-BT

POTTORFF — Model CFD-521-BT

9R. **Alternate Ceiling Damper*** — For use with min 18 in. deep trusses. Not for use with flooring system 1 or 17. Max nom area shall be 256 sq in. with the length not to exceed 24 in. and the width not to exceed 20 in. Max height of damper shall be 17 in. Aggregate damper openings shall not exceed 128 sq in. per 100 sq ft of ceiling area. Damper installed in accordance with the manufacturers installation instructions provided with the damper. A steel grille (Item 10) shall be installed in accordance with installation instructions.

C&S AIR PRODUCTS — Models RD-521-IP, RD-521-NP

POTTORFF — Models CFD-521-IP, CFD-521-NP

9S. Alternate Ceiling Damper* — For use with min 18 in. deep trusses. Not for use with flooring system 1 or 17. Max nom area shall be 144 sq in. with the length not to exceed 14 in. and the width not to exceed 12 in. Max height of damper shall be 17-7/8 in. Aggregate damper openings shall not exceed 74 sq in. per 100 sq ft of ceiling area. Damper installed in accordance with the manufacturers installation instructions provided with the damper. A steel grille (Item 10) shall be installed in accordance with installation instructions.

C&S AIR PRODUCTS — Models RD-521-90, RD-521-NP90

POTTORFF — Models CFD-521-90, CFD-521-90NP

9T. Alternate Ceiling Damper* — (Optional. To be used with Air Duct Item 8.) — For use with min 18 in. deep trusses. For use with Item 4D only. Not for use with flooring system 1. Maximum 20 in. long by 18 in. wide by 2-1/8 in. high, fabricated from galvanized steel. Plenum box maximum size nom. 21 in. long by 18 in. wide by 16 in. high fabricated from either galvanized steel or Classified Air Duct Materials bearing the UL Class 0 or Class 1 rigid air duct material. Installed in accordance with the instructions provided by the manufacturer. Max damper openings not to exceed 180 sq in. per 100 sq ft of ceiling area.

NAILOR INDUSTRIES INC — Types 0755, 0755A, 0756, 0756D, 0757, 0757D, 0757FP, 0757DFP, 0763

SAFE AIR DOWCO — 0455, 0455A, 0456, 0456D, 0457, 0457D, 0457-DB, 0457-CB, 0463-FB, 0457-EB, 0463-GB, 0463

9U. Alternate Ceiling Damper* — (Optional, to be used with Air Duct Item 8) For use with min 18 in. deep trusses. Max nom 11-1/8 in. long by 13-5/8 in. wide, fabricated from galvanized steel. Installed in accordance with the instructions provided by the manufacturer. Max damper openings not to exceed 76 sq in. per 100 sq ft of ceiling area.

GREENHECK FAN CORP — Model CRD-310WT

9V. Alternate Ceiling Damper* — (Optional, to be used with Air Duct Item 8) For use with min 18 in. deep trusses. Max nom 12-3/8 in. long by 14-1/2 in. wide, fabricated from galvanized steel. Installed in accordance with the instructions provided by the manufacturer. Max damper openings not to exceed 90 sq in. per 100 sq ft of ceiling area.

GREENHECK FAN CORP — Model CRD-320WT

9W. Alternate Ceiling Damper* — (Optional, to be used with Air Duct Item 8) For use with min. 18 in. deep trusses. Not for use with flooring system 1 or 17. Max 12 in. diameter damper within max 15 in. by 15 in. register box with max 12 in. by 12 in. register opening fabricated from galvanized steel. Aggregate area of the register opening(s) through the ceiling membrane shall not exceed 72 sq. in. per 100 sq. ft. of ceiling area. Damper assembly installed in accordance with the manufacturer's installation instructions.

RUSKIN COMPANY — Model CFD7T-SR

9X Ceiling Damper* — (Optional. To be used with Air Duct Item 8.) — For use with min. 18 in. deep trusses. Not for use with flooring system 1 or 17. Max 12 in. diameter damper and insulated register box assembly. The maximum size of the register box assembly is nom. 20 in. long by 20 in. wide and 4 in. high fabricated from galv steel. The aggregate area of the register opening(s) through the ceiling membrane shall not exceed 128 sq in. per 100 sq ft of ceiling area. Damper assembly installed in accordance with the manufacturers installation instructions.

SOUTHWARK METAL MFG CO — Model 800 w/Box

9Y Alternate Ceiling Damper* — (Optional. To be used with Air Duct Item 8.) — For use with min. 18 in. deep trusses. Not for use with flooring system 1 or 17. Max 20 in. long by 16 in. wide by 4 in. high rectangular damper with plenum box assembly. The maximum outer dimensions of the plenum box assembly are 23-1/2 in. long by 19-1/2 in. wide and 17 in. high fabricated from 6pcf, 1-1/2 to 2 in. thick Knauf Air Duct Board M*. The aggregate area of the register opening(s) through the ceiling membrane shall not exceed 160 sq in. per 100 sq ft ceiling area. Damper assembly installed in accordance with the manufacturers installation instructions.

SOUTHWARK METAL MFG CO — CRD w/DB Box

9Z Alternate Ceiling Damper* — (Optional. To be used with Air Duct Item 8.) — For use with min. 18 in. deep trusses. Not for use with flooring system 1 or 17. Max 14 in. long by 14 in. wide and 18 in. high ceiling damper with boot or box assembly, fabricated from galv steel. The aggregate area of the register opening(s) through the ceiling membrane shall not exceed 98 sq in. per 100 sq ft of ceiling area. Damper assembly installed in accordance with the manufacturers installation instructions.

SOUTHWARK METAL MFG CO — Model 500 w/Boot, 510 w/Boot, 500 w/Box or 510 w/Box

9AA. **Alternate Ceiling Damper*** — (Optional, to be used with Air Duct Item 8) For use with min 18 in. deep trusses. Max nom 10-3/8 in. long by 10-3/8 in. wide, fabricated from galvanized steel. Installed in accordance with the instructions provided by the manufacturer. Max damper openings not to exceed 54 sq in. per 100 sq ft of ceiling area.

GREENHECK FAN CORP — Model CRD-300WT

9AB. **Alternate Ceiling Damper*** — (Optional. To be used with Air Duct Item 8.) — For use with min. 18 in. deep trusses. Not for use with flooring system 1 or 17. Max 7-11/32 in. long by 7-11/16 in. wide fabricated from galvanized steel. Aggregate area of the register opening(s) through the ceiling membrane shall not exceed 28.5 sq in. per 100 sq ft of ceiling area. Damper assembly installed in accordance with the manufacturer's installation instructions.

AIRE TECHNOLOGIES INC — Models ITG-CRD2.

9AC. **Alternate Ceiling Damper*** — (Optional. To be used with Air Duct Item 8.) — For use with min. 18 in. deep trusses. Not for use with flooring system 1 or 17. Max 9-11/16 in long by 9-1/16 in. wide fabricated from galvanized steel. Aggregate area of the register opening(s) through the ceiling membrane shall not exceed 44.5 sq in. per 100 sq ft of ceiling area. Damper assembly installed in accordance with the manufacturer's installation instructions.

AIRE TECHNOLOGIES INC — Models SIG-CRD2

9AD. **Alternate Ceiling Damper*** — (Optional. To be used with Air Duct Item 8.) — For use with min. 18 in. deep trusses. Not for use with flooring system 1 or 17. Max 10-13/32 in. long by 10-22/32 in. wide fabricated from galvanized steel. Aggregate area of the register opening(s) through the ceiling membrane shall not exceed 56 sq in. per 100 sq ft of ceiling area. Damper assembly installed in accordance with the manufacturer's installation instructions.

AIRE TECHNOLOGIES INC — Models SMT-CRD2

9AE. **Alternate Ceiling Damper*** — (Optional. To be used with Air Duct Item 8.) — For use with min. 18 in. deep trusses. Not for use with flooring system 1 or 17. Max 8-13/16 in. wide and 8-1/2 in. long fabricated from galvanized steel. Aggregate area of the register opening(s) through the ceiling membrane shall not exceed 37.5 sq in. per 100 sq ft of ceiling area. Damper assembly installed in accordance with the manufacturer's installation instructions.

AIRE TECHNOLOGIES INC — Models GBR-CRD2

10. **Grille** — Aluminum or Steel grille, installed in accordance with the installation instructions provided with the ceiling damper.

11. **Discrete Products Installed in Air-handling Spaces*** — Automatic Balancing Valve/Damper — (Not Shown - Optional) — For use with item 9A, Ruskin Company's Model CFD7T damper (CABS). Ceiling damper to be provided with plenum box per damper manufacturer's instructions with side outlet only. Entire assembly to be installed into any UL Class 0 or Class 1 flexible air duct in accordance with the instructions provided by the automatic balancing valve/damper manufacturer.

NAILOR INDUSTRIES INC — Model ABV-4, ABV-5, ABV-6

*** Indicates such products shall bear the UL or cUL Certification Mark for jurisdictions employing the UL or cUL Certification (such as Canada), respectively.**

Last Updated on 2024-09-02

The appearance of a company's name or product in this database does not in itself assure that products so identified have been manufactured under UL Solutions' Follow - Up Service. Only those products bearing the UL Mark should be considered to be Certified and covered under UL Solutions' Follow - Up Service. Always look for the Mark on the product.

UL Solutions permits the reproduction of the material contained in Product iQ subject to the following conditions: 1. The Guide Information, Assemblies, Constructions, Designs, Systems, and/or Certifications (files) must be presented in their entirety and in a non-misleading manner, without any manipulation of the data (or drawings). 2. The statement "Reprinted from Product iQ with permission from UL Solutions" must appear adjacent to the extracted material. In addition, the reprinted material must include a copyright notice in the following format: "©2024 UL LLC."

Design/System/Construction/Assembly Usage Disclaimer

- Authorities Having Jurisdiction should be consulted in all cases as to the particular requirements covering the installation and use of UL Certified products, equipment, system, devices, and materials.
- Authorities Having Jurisdiction should be consulted before construction.
- Fire resistance assemblies and products are developed by the design submitter and have been investigated by UL for compliance with applicable requirements. The published information cannot always address every construction nuance encountered in the field.
- When field issues arise, it is recommended the first contact for assistance be the technical service staff provided by the product manufacturer noted for the design. Users of fire resistance assemblies are advised to consult the general Guide Information for each product category and each group of assemblies. The Guide Information includes specifics concerning alternate materials and alternate methods of construction.
- Only products which bear UL's Mark are considered Certified.

BXUV - Fire Resistance Ratings - ANSI/UL 263 Certified for United States

BXUV7 - Fire Resistance Ratings - CAN/ULC-S101 Certified for Canada

[See General Information for Fire-resistance Ratings - ANSI/UL 263 Certified for United States Design Criteria and Allowable Variances](#)

[See General Information for Fire Resistance Ratings - CAN/ULC-S101 Certified for Canada Design Criteria and Allowable Variances](#)

Design No. P522

June 14, 2024

Unrestrained Assembly Rating — 1 Hr

Finish Rating — 25 Min (See Items 3 or 3A)

This design was evaluated using a load design method other than the Limit States Design Method (e.g., Working Stress Design Method). For jurisdictions employing the Limit States Design Method, such as Canada, a load restriction factor shall be used — See Guide [BXUV](#) or [BXUV7](#)

*** Indicates such products shall bear the UL or cUL Certification Mark for jurisdictions employing the UL or cUL Certification (such as Canada), respectively.**

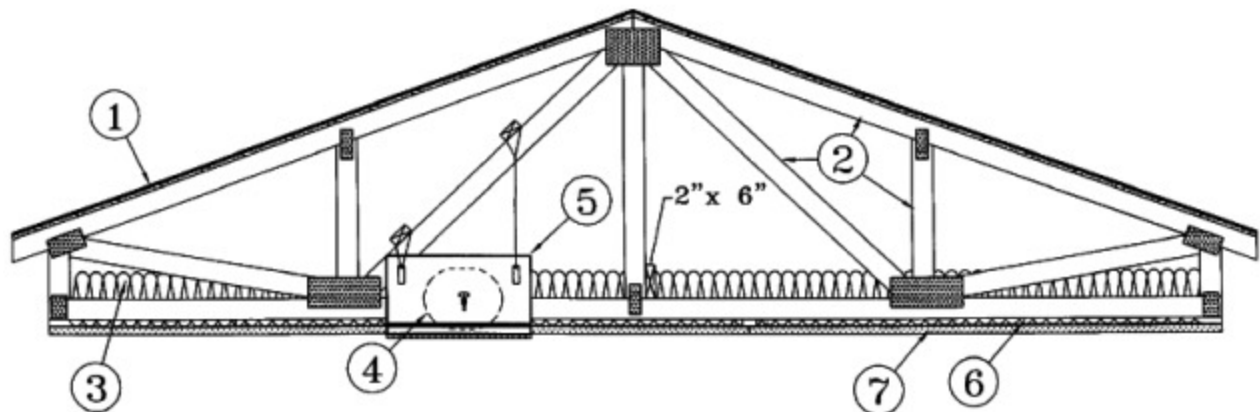
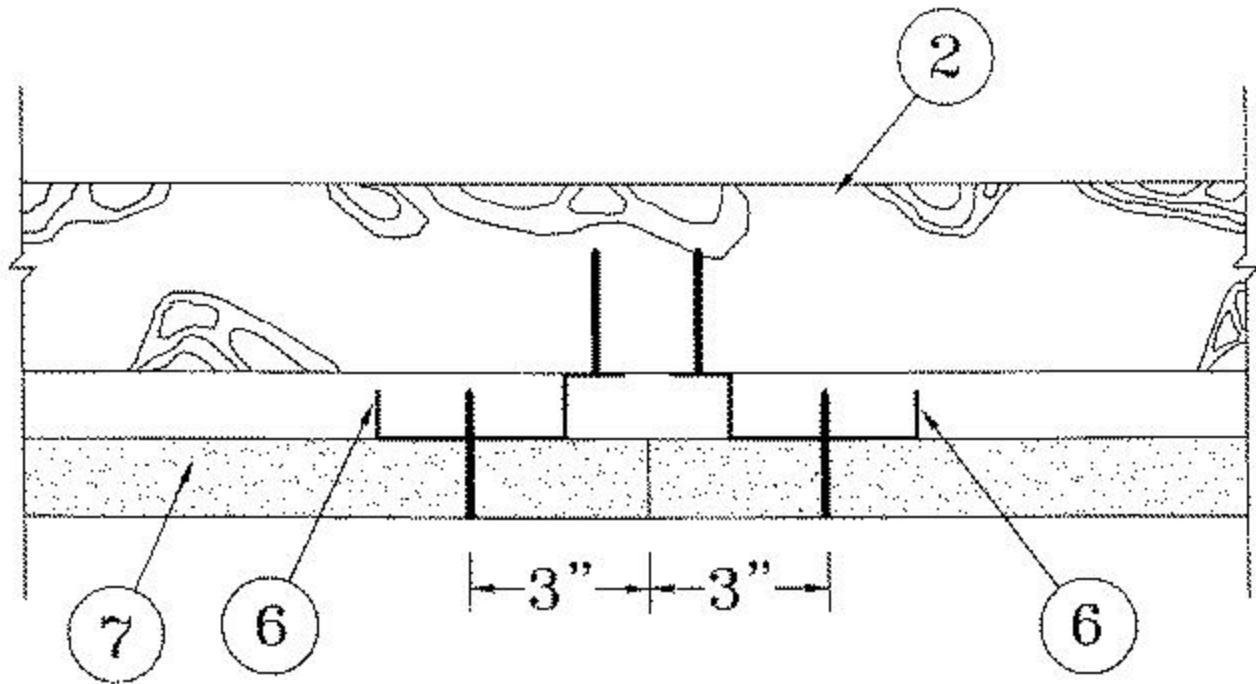
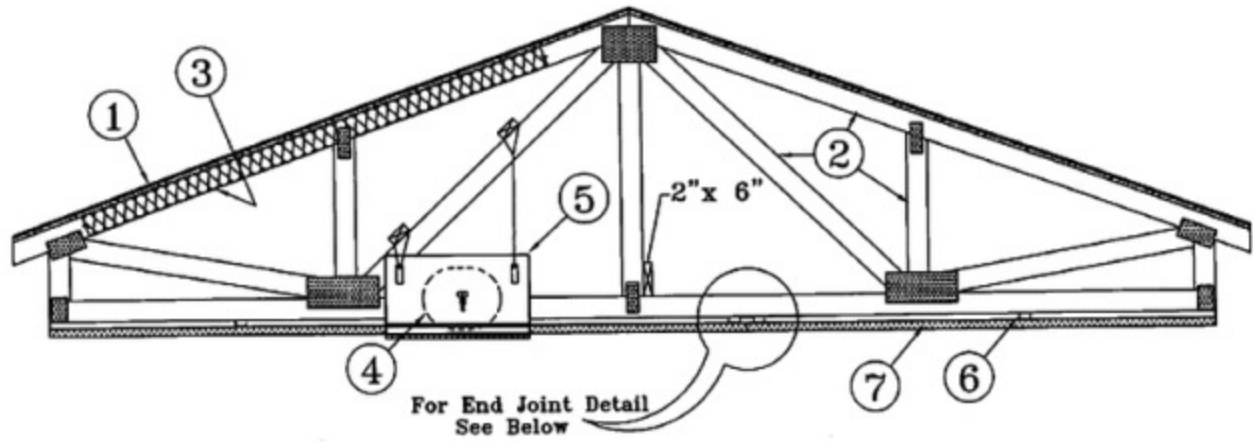

Alternate Insulation Placement

1. **Roofing System*** — Any UL Class A, B or C Roofing System (TGFU) or Prepared Roof Covering (TFWZ) acceptable for use over nom 15/32 in. thick wood structural panels, min. grade "C-D" or "Sheathing". Nom 15/32 in. thick wood structural panels secured to trusses with No. 6d ringed shank nails spaced 12 in. OC along each truss. Staples having equal or greater withdrawal and lateral resistance strength may be substituted for the 6d nails. Construction adhesive may be used with either the nails or staples.

2. **Trusses** — Pitched or parallel chord wood trusses, spaced a max of 24 in. OC, fabricated from nom 2 by 4 lumber, with lumber oriented vertically or horizontally. Truss members secured together with min. 0.0356 in. thick galv steel plates. Plates have 5/16 in. long teeth projecting perpendicular to the plane of the plate. The teeth are in pairs facing each other (made by the same punch), forming a split tooth type plate. Each tooth has a chisel point on its outside edge. These points are diagonally opposite each other for each pair. The top half of each tooth has a twist for stiffness. The pairs are repeated on approximately 7/8 in. centers with four rows of teeth per inch of plate width. Minimum parallel chord truss depth shall be 18 in. Where pitched truss intersects with the interior face of the exterior walls, the min truss depth shall be 5-1/4 in. with a min roof slope of 3/12 and a min. average depth of 18 in.. Where the truss intersects with the interior face of the exterior walls, the min truss depth may be reduced to 3 in. if the batts and blankets (Item 3) are used as shown in the above illustration (Alternate Insulation Placement) and are firmly packed against the intersection of the bottom chords and the plywood sheathing.

3. **Batts and Blankets*** — (Optional) — Required when Item 6B is used — Glass fiber insulation, secured to the wood structural panels with staples spaced 12 in. OC or to the trusses with 0.090 in. diam galv steel wires spaced 12 in. OC. Any glass fiber insulation bearing the UL Classification Marking as to Surface Burning Characteristics and/or Fire Resistance, having a min density of 0.5 pcf. As an option, the insulation may be fitted in the concealed space, draped over the resilient channel/gypsum board ceiling membrane when resilient channels and gypsum board attachment is modified as specified in Items 6 and 7. When **Steel Framing Members** (Item 6B) are used, max 3-1/2 in. thick insulation shall be draped over the furring channels (Item 6Ba) and gypsum board ceiling membrane, and friction-fitted between trusses and Steel Framing Members (Item 6Bd). The finished rating has only been determined when the insulation is secured to the decking.

3A. **Fiber, Sprayed*** — As an alternate to Item 3 (not evaluated for use with Item 6B) — Any thickness of spray-applied cellulose insulation material, having a min density of 0.5 lb/ft³, applied with water, over the resilient channel/gypsum board ceiling membrane when resilient channels and gypsum board attachment is modified as specified in Items 6 and 7. Fiber, Sprayed is applied with moisture in accordance with the application instructions supplied with the product. The finish rating when Fiber Sprayed is used has not been determined. Alternate application method: The fiber is applied without water or adhesive in accordance with the application instructions supplied with a minimum density of 0.5 lb/ft³ over the resilient channel/gypsum board ceiling membrane when resilient channels and gypsum board attachment is modified as specified in Items 6 and 7. Alternate application method: The fiber is applied without water or adhesive to a nominal density of 3.5 lb/ft³ behind netting (Item 9) stapled to the rafters. The netting is stapled at both lower edges of the rafters creating a cavity to accept the cellulose fiber.

APPLEGATE GREENFIBER ACQUISITION LLC — SANCTUARY for use with wet or dry application. Insulmax are to be used for dry application only.

3B. **Foamed Plastic*** — (As an alternate to Item 3 or 3A, Not Shown) — Spray foam insulation applied directly to the underside of the underside of the roofing system (Item 1). Spray foam insulation installed to a maximum thickness of 10 in. at a nominal 0.5 lb/ft³ density, while maintaining a minimum 8-1/2 in. clearance between the spray foam insulation and the gypsum board (Item 7). When spray foam insulation is used, resilient channels (Item 6) shall be installed maximum 12 in. OC, with channels adjacent to butt joints of gypsum board (Item 7) installed at 6 in. OC to allow for maximum 3 in. spacing off ends of the gypsum board joints. Gypsum board (Item 7) to be installed using 1-1/4 in. long Type S screws, spaced maximum 8 in. OC, and butted end joints shall be staggered min. 2 ft within the assembly, and occur midway between the continuous furring channels. If used with a fire damper (Items 5 through 5K) in the concealed space, minimum 1 in. clearance to be maintained between damper housing and spray foam insulation. Not evaluated for use with Items 6A through 6F.

Holcim Solutions and Products US, LLC — Sucraseal

3C. **Cavity Insulation - Batts and Blankets* or Fiber, Sprayed*** — (As described above) in Items 3 and 3A — (For Use with Item 7B, Not Shown) — Min. 3-1/2 in thick with no limit on maximum thickness fitted in the concealed space, draped over the resilient channel (Item 6G)/gypsum board (Item 7B) ceiling membrane.

3D. **Foamed Plastic*** — (As alternate to Item 3, 3A, or 3B, Not Shown) — Spray foam insulation applied directly to the underside of the roofing system (Item 1). Spray foam insulation installed to a maximum thickness of 10 in. at a nominal 0.5 lb/ft³ or 2.0 lb/ft³ density, depending on the product installed. When spray foam insulation is installed, resilient channels (Item 6) shall be installed maximum 12 in. OC, with channels adjacent to butt joints of gypsum board (Item 7) spaced maximum 3 in. away from gypsum butt joints. Gypsum board (Item 7) to be installed using minimum 1-1/4 in. long Type S screws, spaced maximum 8 in. OC, and butted end joints shall be staggered min. 2 ft within the assembly, and occur midway between the continuous furring channels. If used with a fire

damper (Items 5 through 5H) in the concealed space, minimum 1 in. clearance to be maintained between damper housing and spray foam insulation. Not evaluated for use with Items 6A through 6F.

BASF CORP — Enertite® NM, Enertite® G, FE178®, Spraytite® 178, Spraytite® 81206, Walltite® 200, Walltite® US, Walltite® US-N, Walltite® HP+, Walltite® MAX, Walltite® v.5, Walltite® LWP, Walltite® Plus and Enertite® Max

3E. Foamed Plastic* — (As an alternate to Item 3, 3A, 3B, 3C, or 3D, Not Shown) — Spray foam insulation applied directly to the underside of the underside of the roofing system (Item 1). Spray foam insulation installed to a maximum thickness of 17 in. at a nominal 0.5 lb/ft³ density, while maintaining a minimum 1-1/2 in. clearance between the spray foam insulation and the gypsum board (Item 7). When spray foam insulation is used, resilient channels (Item 6) shall be installed maximum 12 in. OC, with channels adjacent to butt joints of gypsum board (Item 7) installed at 6 in. OC to allow for maximum 3 in. spacing off ends of the gypsum board joints. Gypsum board (Item 7) to be installed using 1-1/4 in. long Type S screws, spaced maximum 8 in. OC, and butted end joints shall be staggered min. 2 ft within the assembly, and occur midway between the continuous furring channels. If used with a fire damper (Items 5 through 5K) in the concealed space, no clearance is necessary between damper housing and spray foam insulation. Not evaluated for use with Items 6A through 6F.

Holcim Solutions and Products US, LLC — EasySeal.5, EasySeal ULD

3F. Foamed Plastic* — (As alternate to Item 3) — Spray foam insulation applied directly to the underside of the roofing system (Item 1). Spray foam insulation installed to a maximum thickness of 11 in. at a nominal 0.5 lb/ft³ - 2.5 lb/ft³ density, while maintaining a minimum 7 in. clearance between the spray foam insulation and the gypsum board (Item 7). When spray foam insulation is installed, resilient channels (Item 6) shall be installed maximum 12 in. OC, with channels adjacent to butt joints of gypsum board spaced maximum 3 in. away from gypsum butt joints. Gypsum board to be installed using minimum 1-1/4 in. long Type S screws, spaced maximum 8 in. OC, and butted end joints shall be staggered min. 2 ft within the assembly, and occur midway between the continuous furring channels. If used with a fire damper (Items 5 through 5K) in the concealed space, no clearance is necessary between damper housing and spray foam insulation. Only for use with item 6 not evaluated for use with alternates to item 6.

CARLISLE SPRAY FOAM INSULATION — Types SealTite Pro Closed Cell (CC), SealTite Pro Open Cell (OC), SealTite Pro OCX, SealTite Pro No Trim 21, SealTite Pro One Zero, SealTite PRO HFO, Foamsulate Closed Cell, Foamsulate OCX, Foamsulate 70, Foamsulate HFO, and Foamsulate HFO 2.0.

3G. Foamed Plastic* — (As an alternate to Item 3, 3A, 3B, 3C, or 3D, Not Shown) — Spray foam insulation applied directly to the underside of the underside of the roofing system (Item 1). Spray foam insulation installed to a maximum thickness of 17 in. at a nominal 0.5 lb/ft³ density, while maintaining a minimum 1-1/2 in. clearance between the spray foam insulation and the gypsum board (Item 7). When spray foam insulation is used, resilient channels (Item 6) shall be installed maximum 12 in. OC, with channels adjacent to butt joints of gypsum board (Item 7) installed at 6 in. OC to allow for maximum 3 in. spacing off ends of the gypsum board joints. Gypsum board (Item 7) to be installed using 1-1/4 in. long Type S screws, spaced maximum 8 in. OC, and butted end joints shall be staggered min. 2 ft within the assembly, and occur midway between the continuous furring channels. If used with a fire damper (Items 5 through 5K) in the concealed space, no clearance is necessary between damper housing and spray foam insulation. Not evaluated for use with Items 6A through 6F.

EVEREST SYSTEMS LLC — Opticell 0.5

4. Air Duct* — For use with **Ceiling Dampers*** - Any UL Class 0 or Class 1 flexible air duct installed in accordance with the instructions provided by the damper manufacturer.

5. Ceiling Damper* — Max nom area, 324 sq in. Max square size, 18 in. by 18 in. rectangular sizes not to exceed 324 sq in. with a max width of 18 in. Max damper height is 14 in. Installed in accordance with manufacturers installation instructions provided with the damper. Max damper openings not to exceed 162 sq in. per 100 sq ft of ceiling area.

C&S AIR PRODUCTS — Model RD-521

POTTORFF — Model CFD-521

5A. Alternate Ceiling Damper* — Max nom area, 196 sq in. Max square size, 14 in. by 14 in. Rectangular sizes not to exceed 196 sq in. with a max width of 26 in. Max overall damper height is 7 in. Installed in accordance with the manufacturers installation instructions provided with the damper. Max damper openings not to exceed 98 sq in. per 100 sq ft of ceiling area.

C&S AIR PRODUCTS — Model RD-521-BT

POTTORFF — Model CFD-521-BT.

5B. Alternate Ceiling Damper* — Max nom area shall be 256 sq in. with the length not to exceed 24 in. and the width not to exceed 20 in. Max height of damper shall be 17 in. Aggregate damper openings shall not exceed 128 sq in. per 100 sq ft of ceiling area. Damper installed in accordance with the manufacturers installation instructions provided with the damper. A steel grille shall be installed in accordance with installation instructions.

C&S AIR PRODUCTS — Model RD-521-IP, RD-521-NP

POTTORFF — Models CFD-521-IP, CFD-521-NP

5C. Alternate Ceiling Damper* — Ceiling damper & fan assembly. Max nom area shall be 75 sq in. with the length not to exceed 8-9/16 in. and the width not to exceed 8-3/4 in. Max height of damper shall be 9-7/8 in. Aggregate damper openings shall not exceed 38 sq in. per 100 sq ft of ceiling area. Damper shall be installed in combination with one of the fan models described in, and in accordance with, the manufacturers installation instructions provided with the damper. A plastic grille shall be installed in accordance with installation instructions.

DELTA ELECTRONICS INC — Models CRD2, GBR-CRD, ITG-CRD

5D. Alternate Ceiling Damper* — Ceiling damper & fan. Max nom area shall be 75 sq in. with the length not to exceed 9-1/4 in. and the width not to exceed 9-3/4 in. Max height of damper shall be 9-7/8 in. Aggregate damper openings shall not exceed 45 sq in. per 100 sq ft of ceiling area. Damper shall be installed in combination with one of the fan models described in, and in accordance with, the manufacturer's installation instructions provided with the damper. A plastic grille shall be installed in accordance with installation instructions.

DELTA ELECTRONICS INC — Model SIG-CRD

5E. Alternate Ceiling Damper* — Max nom area shall be 144 sq in. with the length not to exceed 14 in. and the width not to exceed 12 in. Max height of damper shall be 17-7/8 in. Aggregate damper openings shall not exceed 74 sq in. per 100 sq ft of ceiling area. Damper installed in accordance with the manufacturers installation instructions provided with the damper. A steel grille shall be installed in accordance with installation instructions.

C&S AIR PRODUCTS — Model RD-521-90, RD-521-NP90

POTTORFF — Models CFD-521-90, CFD-521-90NP

5F. Alternate Ceiling Damper* — Ceiling damper & fan assembly. Max nom area shall be 131 sq in. with the length not to exceed 11-1/16 in. and the width not to exceed 11-7/8 in. Aggregate damper openings shall not exceed 66 sq in. per 100 sq ft of ceiling area. Damper shall be installed in combination with one of the fan models described in, and in accordance with, the manufacturer's installation instructions provided with the damper. A plastic grille shall be installed in accordance with installation instructions.

DELTA ELECTRONICS INC — Model SMT-CRD

5G. Alternate Ceiling Damper* — Ceiling damper & fan assembly. Max nom area shall be 103 sq in. with the length not to exceed 10-1/8 in. and the width not to exceed 10-1/8 in. Aggregate damper openings shall not exceed 52 sq in. per 100 sq ft of ceiling area.

Damper shall be installed in combination with one of the fan models described in, and in accordance with, the manufacturer's installation instructions provided with the damper. A plastic grille shall be installed in accordance with installation instructions.
PANASONIC CORPORATION, PANASONIC CORPORATION OF NORTH AMERICA — Model PC-RD05C5

5H. **Alternate Ceiling Damper*** — Ceiling damper & fan assembly. Max nom area shall be 113 sq in. with the length not to exceed 10-1/8 in. and the width not to exceed 11-1/8 in. Aggregate damper openings shall not exceed 57 sq in. per 100 sq ft of ceiling area. Damper shall be installed in combination with one of the fan models described in, and in accordance with, the manufacturer's installation instructions provided with the damper. A plastic grille shall be installed in accordance with installation instructions.
BROAN-NUTONE L L C — Model RDFUWT

5I. **Alternate Ceiling Damper*** — Ceiling damper & fan. Max nom area shall be 79 sq in. with the length not to exceed 10 in. and the width not to exceed 7-15/16 in. Aggregate damper openings shall not exceed 40 sq in. per 100 sq ft of ceiling area. Damper shall be installed in combination with one of the fan models described in, and in accordance with, the manufacturer's installation instructions provided with the damper. A metallic grille shall be installed in accordance with installation instructions.
BROAN-NUTONE L L C — Models RDJ1 and RDH

5J. **Alternate Ceiling Damper*** — Ceiling damper & fan assembly. Max nom area shall be 87 sq in. with the length not to exceed 9 in. and the width not to exceed 9-11/16 in. Aggregate damper openings shall not exceed 44 sq in. per 100 sq ft of ceiling area. Damper shall be installed in combination with one of the fan models described in, and in accordance with, the manufacturer's installation instructions provided with the damper. A plastic grille shall be installed in accordance with installation instructions.
BROAN-NUTONE L L C — Model RDMWT

5K. **Alternate Ceiling Damper*** — Ceiling damper & fan assembly. Max nom area shall be 87 sq in. with the length not to exceed 9 in. and the width not to exceed 9-11/16 in. Aggregate damper openings shall not exceed 44 sq in. per 100 sq ft of ceiling area. Damper shall be installed in combination with one of the fan models described in, and in accordance with, the manufacturer's installation instructions provided with the damper. A plastic grille shall be installed in accordance with installation instructions.
BROAN-NUTONE L L C — Model RDMWT2

6. **Furring Channels** — Resilient channels formed of 25 MSG thick galv steel. Installed perpendicular to the trusses (Item 2), spaced a max of 16 in. OC when no insulation (Item 3 or 3A) is fitted in the concealed space, or a max of 12 in. OC when insulation (Item 3 or 3A) is fitted in the concealed space, draped over the resilient channel/gypsum board ceiling membrane, or when insulation (Item 3B, 3D or 3E) is applied to the underside of the roofing system (Item 1). Two courses of resilient channel positioned 6 in. OC at wallboard butt-joints (3 in. from each end of wallboard). Channels oriented opposite at wallboard butt-joints. Channel splices overlapped 4 in. beneath wood trusses. Channels secured to each truss with 1-1/4 in. long Type S screws.

6A. **Steel Framing Members*** — (Not Shown) — As an alternate to Item 6, furring channels and Steel Framing Members as described below:

a. **Furring Channels** — Formed of No. 25 MSG galv steel. 2-9/16 in. or 2-23/32 in. wide by 7/8 in. deep, spaced 16 in. OC perpendicular to trusses when no insulation (Items 3 or 3A) is fitted in the concealed space or 12 in. OC when insulation (Items 3 or 3A) is fitted in the concealed space, draped over the furring channel/gypsum board ceiling membrane or 24 in. OC when insulation (Items 3 or 3A) is fitted in the concealed space, draped over the furring channel/gypsum board ceiling membrane and a second layer of gypsum board is attached as described in Item 7 for steel framing members. Channels secured to trusses as described in Item 6Ab. Ends of adjoining channels overlapped 6 in. and tied together with double strand of No. 18 SWG galv steel wire near each end of overlap.

b. **Steel Framing Members** — Used to attach furring channels (Item a) to trusses (Item 2). Clips spaced 48 in. OC. RSIC-1 and RSIC-1 (2.75) clips secured to alternating trusses with No. 8 by 2-1/2 in. coarse drywall screw through the center grommet. RSIC-V and RSIC-V (2.75) clips secured to alternating trusses with No. 8 by 1-1/2 in. coarse drywall screw through the center hole. Furring channels are

friction fitted into clips. RSIC-1 and RSIC-V clips for use with 2-9/16 in. wide furring channels. RSIC-1 (2.75) and RSIC-V (2.75) clips for use with 2-23/32 in. wide furring channels. Adjoining channels are overlapped as described in Item 6Aa. As an alternate, ends of adjoining channels may be overlapped 6 in. and secured together with two self-tapping No. 6 framing screws, min. 7/16 in. long at the midpoint of the overlap, with one screw on each flange of the channel. Additional clips required to hold furring channel that supports the gypsum board butt joints, as described in Item 7.

PAC INTERNATIONAL L L C — Types RSIC-1, RSIC-V, RSIC-1 (2.75), RSIC-V (2.75).

6B. Steel Framing Members* — (Not Shown) — As an alternate to Items 6 and 6A.

a. **Furring Channels** — Hat-shaped furring channels, 7/8 in. deep by 2-5/8 in. wide at the base and 1-1/4 in. wide at the face, formed from No. 25 ga. galv steel, spaced max 16 in. OC perpendicular to trusses and Cold Rolled Channels (Item 6Bb). Furring channels secured to Cold Rolled Channels at every intersection with a 1/2 in. pan head self-drilling screw through each furring channel leg. Ends of adjoining channels overlapped 4 in. and tied together with two double strand No. 18 SWG galv steel wire ties, one at each end of overlap. Supplemental furring channels at base layer and outer layer gypsum board butt joints are not required. Batts and Blankets draped over furring channels as described in Item 3. Two layers of gypsum board attached to furring channels as described in Item 7.

b. **Cold Rolled Channels** — 1-1/2 in. by 1/2 in., formed from No. 16 ga. galv steel, positioned vertically and parallel to trusses, friction-fitted into the channel caddy on the Steel Framing Members (Item 6Bd). Adjoining lengths of cold rolled channels lapped min. 6 in. and wire-tied together with two double strand 18 SWG galv steel wire ties, one at each end of overlap.

c. **Blocking** — Where truss design does not permit direct, full contact of the hanger bracket, a piece of nominal 2 by 4 in. lumber (blocking), min. 6 in. long to permit full contact of the hanger bracket, to be secured vertically to the side of the truss (Item 2) at the top and bottom of the blocking at each Steel Framing Member (Item 6Bd) location.

d. **Steel Framing Members*** — Hangers spaced 48 in. OC. max along truss, and secured to the Blocking (Item 6Bc) on alternating trusses with a single 5/16 in. by 2 in. hex head lag bolt or four #6 1-1/4 in. drywall screws through mounting hole(s) on the hanger bracket. The two 1/4 in. long steel teeth on the hanger are embedded in the side of the blocking. Hanger positioned on blocking and leveling bolt height adjusted such that furring channels are flush with bottom of trusses before gypsum board installation. Spring gauge of hanger chosen per manufacturer's instructions.

KINETICS NOISE CONTROL INC — Type ICW.

6C. Steel Framing Members* — (Not Shown) — As an alternate to Items 6, 6A and 6B.

a. **Furring Channels** — Formed of No. 25 MSG galv steel, 2-3/8 in. wide by 7/8 in. deep installed perpendicular to wood structural members. Channels spaced a max of 16 in. OC when no insulation (Item 3 or 3A) is fitted in the concealed space or a max of 12 in. OC when insulation (Item 3 or 3A) is fitted in the concealed space. Channels secured to trusses as described in Item 6Cb. Ends of adjoining channels overlapped 6 in. and tied together with double strand of No. 18 AWG galvanized steel wire near each end of overlap.

b. **Steel Framing Members*** — Used to attach furring channels (Item 6Ca) to trusses (Item 2). Clips secured to the bottom chord of each truss (48 in. OC) with one No. 8 by 2-1/2 in. long coarse drywall screw through center grommet. Furring channels are friction fitted into clips. Adjoining channels are overlapped as described in Item 6Ca. As an alternate, ends of adjoining channels may be overlapped 6 in. and secured together with two self-tapping No. 6 framing screws, min 7/16 in. long at the midpoint of the overlap, with one screw on each flange of the channel. Additional clips required to hold furring channel that supports the gypsum board butt joints, as described in Item 7.

PLITEQ INC — Type Genie Clip

6D. Steel Framing Members* — (Not Shown) — As an alternate to Items 6, 6A, 6B and 6C.

a. **Main runners** — Installed perpendicular to trusses — Nom 10 or 12 ft long, 15/16 in. or 1-1/2 in. wide face, spaced 4 ft OC. Main runners hung a min of 2 in. from bottom chord of trusses with 12 SWG galv steel wire. Wires located a max of 48 in. OC.

b. **Cross tees or channels** — Nom 4 ft long, 15/16 in. or 1-1/2 in. wide face or cross channels, nom 4 ft long, 1-1/2 wide face, installed perpendicular to the main runners, spaced 16 in. OC. Additional cross tees or channels used at 8 in. from each side of butted gypsum

board end joints. The cross tees or channels may be riveted or screw-attached to the wall angle or channel to facilitate the ceiling installation.

c. **Wall angles or channels** — Used to support steel framing member ends and for screw-attachment of the gypsum wallboard — Min 0.016 in. thick painted or galvanized steel angle with 1 in. legs or min. 0.016 in. thick painted or galvanized steel channel with a 1 by 1-1/2 by 1 in. profile, attached to walls at perimeter of ceiling with fasteners 16 in. OC.

CGC INC — Type DGL or RX

USG INTERIORS LLC — Type DGL or RX

6E. **Alternate Steel Framing Members*** — (Not Shown) — As an alternate to items 6, 6A, 6B, and 6C, furring channels and Steel Framing Members as described below.

a. **Furring Channels** — Formed of No. 25 MSG galv steel, 2-5/8 in. wide by 7/8 in deep, spaced 16 in OC, perpendicular to trusses. When insulation, Items 3 or 3A is used, the furring channel spacing shall be reduced to 12 in. OC. Channels secured to joists as described in Item b.

b. **Steel Framing Members*** — Used to attach furring channels (Item a) to the wood trusses (Item 2). Clips spaced at 48" OC and secured to the bottom of the trusses with one 2 in. Coarse Drywall Screw with 1 in. diam washer through the center hole. Furring channels are then friction fitted into clips. Ends of channels are overlapped 6" and tied together with double strand of No. 18 AWG galvanized steel wire. Additional clips are required to hold the Gypsum Butt joints as described in Item 7.

STUDCO BUILDING SYSTEMS — RESILMOUNT Sound Isolation Clips - Type A237 or A237R

6F. **Steel Framing Members*** — (Not Shown) — As an alternate to Items 6 through 6E- Not for use with Items 3 or 3A. Main runners nom 12 ft long, spaced 72 in. OC. Main runners suspended by min 12 SWG galv steel hanger wires spaced 48 in. OC. Cross tees, nom 6 ft long, installed perpendicular to main runners and spaced 24 in. OC. Additional 6 ft long cross tees required at each gypsum board end joint with butted gypsum board end joints centered between cross tees spaced 8 in. OC. The main runners and cross tees may be riveted or screw attached to the wall angle or channel to facilitate the ceiling installation.

USG INTERIORS LLC — Type DGL or RX

6G. **Resilient Channels** — For Use With Item 7B - Formed from min 25 MSG galv steel installed perpendicular to trusses and spaced 16 in. OC. Channels secured to each truss with 1-5/8 in. long Type S bugle head steel screws. Channels overlapped 4 in. at splices. Two channels, spaced 6 in. OC, oriented opposite each gypsum panel end joint. Additional channels shall extend min 6 in. beyond each side edge of panel. Insulation, Item 3C is applied over the resilient channel/gypsum panel ceiling membrane.

6H. **Alternate Steel Framing Members*** — (Not Shown) — As an alternate to items 6 through 6G, furring channels and Steel Framing Members as described below.

a. **Furring Channels** — Formed of No. 25 MSG galv steel, 2-1/2 in. wide by 7/8 in deep, spaced 16 in OC, perpendicular to trusses. When insulation, Items 3 or 3A is used, the furring channel spacing shall be reduced to 12 in. OC. Channels secured to joists as described in Item b.

b. **Steel Framing Members*** — Used to attach furring channels (Item a) to the wood trusses (Item 2). Clips spaced at 48" OC and secured to the bottom of the trusses with one 2-1/2 in. Coarse Drywall Screw with 1 in. diam washer through the center hole. Furring channels are then friction fitted into clips. Ends of channels are overlapped 6" and tied together with double strand of No. 18 AWG galvanized steel wire. Additional clips are required to hold the Gypsum Butt joints as described in Item 7.

REGUPOL AMERICA — Type SonusClip

7. **Gypsum Board*** — One layer of nom 5/8 in. thick by 48 in. wide boards, installed with long dimension parallel to trusses. Attached to the resilient channels using 1 in. long Type S bugle-head screws. Screws spaced a max of 12 in. OC along butted end-joints and in the field when no insulation (Item 3 or 3A) is fitted in the concealed spaced, or a max of 8 in. OC along butted end-joints and in the

field when insulation (Item 3 or 3A) is fitted in the concealed space, draped over the resilient channel/gypsum board ceiling membrane. When insulation (Item 3B, 3D or 3E) is installed in the concealed space, spray-applied to the underside of the roofing system (Item 1), screws are spaced a max of 8 in. OC along resilient channels, fasteners are increased in length to 1-1/4 in, and gypsum board butt joints shall be staggered min. 2 ft within the assembly, and occur between the main furring channels.

When **Steel Framing Members*** (Item 6A or 6C) are used, sheets installed with long dimension perpendicular to furring channels and side joints of sheet located beneath trusses. Gypsum board screws are driven through channel spaced 12 in. OC in the field when no insulation (Item 3 or 3A) is fitted in the concealed space, or 8 in. OC in the field when insulation (Item 3 or 3A) is fitted in the concealed space, draped over the furring channel/gypsum board ceiling membrane. Gypsum board butt joints shall be staggered min. 2 ft within the assembly, and occur between the main furring channels. At the gypsum board butt joints, each end of the gypsum board shall be supported by a single length of furring channel equal to the width of the wallboard plus 6 in. on each end. The furring channels shall be spaced approximately 3-1/2 in. OC, and be attached to the trusses with one clip at each end of the channel. Screw spacing along the butt joint to attach the gypsum board to the furring channels shall be 8 in. OC. Second (outer) layer of gypsum board required when furring channels (Item 6A, a) are spaced 24 in. OC and insulation is fitted in the concealed space, draped over the furring channel/gypsum board ceiling membrane. Outer layer of gypsum board attached to the furring channels using 1-5/8 in. long Type S bugle-head screws spaced 8 in. OC at butted joints and 12 in. OC in the field. Butted end joints of outer layer to be offset a minimum of 8 in. from base layer end joints. Butted side joints of outer layer to be offset minimum 18 in. from butted side joints of base layer.

When **Steel Framing Members** (Item 6B) are used, two layers of nom 5/8 in. thick, 4 ft wide gypsum board are installed with long dimensions perpendicular to furring channels (Item 6Ba). Base layer attached to the furring channels using 1 in. long Type S bugle head steel screws spaced 8 in. OC along butted end joints and 12 in. OC in the field of the board. Butted end joints centered on the continuous furring channels. Butted base layer end joints to be offset a min of 16 in. in adjacent courses. Outer layer attached to the furring channels using 1-5/8 in. long Type S bugle head steel screws spaced 8 in. OC at butted end joints and 12 in. OC in the field. Butted end joints centered on the continuous furring channels and offset a min of 16 in. from butted end joints of base layer. Butted side joints of outer layer to be offset min 16 in. from butted side joints of base layer.

When **Steel Framing Members** (Item 6C) are used, one layer of nom 5/8 in. thick, 4 ft wide gypsum board is installed with long dimensions perpendicular to furring channels. Gypsum board secured to furring channels with nom 1 in. long Type S bugle-head steel screws spaced 8 in. OC in the field of the board. Gypsum board butted end joints shall be staggered minimum 72 in. At the gypsum board butt joints, each end of each gypsum board shall be supported by a single length of furring channel equal to the width of the gypsum board plus 3 in. on each end, spaced approximately 2 in. in from joint. Screw spacing along the gypsum board butt joint shall be 8 in. OC. Butt joint furring channels shall be attached with a RESILMOUNT Sound Isolation Clip secured to underside of every truss that is located over the butt joint. Over all Gypsum Board side joints, approximately 20 in. lengths of furring channel shall be installed parallel to trusses (Item 2) between main furring channels. Side joint furring channels shall be attached to underside of the joist with RESILMOUNT Sound Isolation Clips - located approximately 2 in. from each end of the approximate 20 in. length of channel. Both Gypsum Boards at side joints fastened into channel with screws spaced 8 in. OC, approximately 1/2 in. from joint edge.

When **Steel Framing Members** (Item 6E) are used, one layer of nom 5/8 in. thick, 4 ft wide gypsum board is installed with long dimensions perpendicular to furring channels. Gypsum board secured to furring channels with nom 1 in. long Type S bugle-head steel screws spaced 8 in. OC in the field of the board. Gypsum board butted end joints shall be staggered minimum 48 in. and centered over main furring channels. At the gypsum board butt joints, each end of each gypsum board shall be supported by a single length of furring channel equal to the width of the gypsum board plus 3 in. on each end. The two support furring channels shall be spaced approximately 3 in. in from end joint. Screw spacing along the gypsum board butt joint and along both additional channels shall be 8 in. OC. Additional screws shall be placed in the adjacent section of gypsum board into the aforementioned 3 in. extension of the extra butt joint channels as well as into the main channel that runs between. Butt joint furring channels shall be attached with one RESILMOUNT Sound Isolation Clip at each end of the channel.

When alternate **Steel Framing Members*** (Item 6F) are used, one layer of nom 5/8 in. thick, 4 ft wide gypsum board sheets installed with long dimension (side joints) perpendicular to the 6 ft long cross tees with the end joints staggered min 4 ft and centered between cross tees which are spaced 8 in. OC. Gypsum board side joints may occur beneath or between main runners. Prior to installation of the gypsum board sheets, backer strips consisting of nom 7-3/4 in. wide pieces of gypsum board are to be laid atop the cross tee flanges and centered over each butted end joint location. The backer strips are to be secured to the flanges of the cross tees at opposite corners of the backer strip with hold down clips to prevent the backer strips from being uplifted during screw-attachment of the gypsum board sheets. Gypsum board fastened to cross tees with 1 in. drywall screws spaced 1 in. and 4 in. from the side joints and max 8 in. OC in the field of the board. The butted end joints are to be secured to the backer strip with No. 10 by 1-1/2 in. long Type G laminating screws located 1 in. from each side of the butted end joint and spaced 1 in. and 4 in. from the side joints and max 8 in. OC in the field of the board.

When **Steel Framing Members** (Item 6H) are used, one layer of nom 5/8 in. thick, 4 ft wide gypsum board is installed with long dimensions perpendicular to furring channels. Gypsum board secured to furring channels with nom 1 in. long Type S bugle-head steel screws spaced 8 in. OC in the field of the board. Gypsum board butted end joints shall be staggered minimum 48 in. and centered over main furring channels. At the gypsum board butt joints, an additional single length of furring channel shall be installed and be spaced approximately 3 in. from the butt joint (6 in. from the continuous furring channels) to support the floating end of the gypsum board. Each of these shorter sections of furring channel shall extend one truss beyond the width of the gypsum panel and be attached to the adjacent trusses with one SonusClip at every truss involved with the butt joint.

CGC INC — Types C, IP-X2, IPC-AR

UNITED STATES GYPSUM CO — Types C, IP-X2, IPC-AR

USG BORAL DRYWALL SFZ LLC — Type C

USG MEXICO S A DE C V — Types C, IP-X2, IPC-AR

7A. **Gypsum Board*** — For use with Steel Framing Members (Item 6D) when Batts and Blankets* (Item 3) are not used - One layer of nom 5/8 in. thick by 48 in. wide boards, installed with long dimension parallel to the main runners. Gypsum board fastened to each cross tee or channel with five wallboard screws, with one screw located at the midspan of the cross tee or channel, one screw located 12 in. from and on each side of the cross tee or channel mid span and one screw located 1-1/2 in. from each gypsum board side joint. Except at wallboard end joints, wallboard screws shall be located on alternating sides of cross tee flange. At gypsum board end joints, gypsum board screws shall be located 1/2 in. from the joint. Gypsum board fastened to main runners with wallboard screws 1/2 in. from side joints, midway between intersections with cross tees or channels (16 in. OC). End joints of adjacent gypsum board sheets shall be staggered not less than 32 in. Gypsum board sheets screw attached to leg of wall angle with wallboard screws spaced 12 in. OC. Joints treated as described in Item 7. For use with **Steel Framing Members*** (Item 6D) when **Batts and Blankets*** (Item 3) are used - Ratings limited to 1 Hour - 5/8 in. thick, 4 ft wide; installed with long dimension perpendicular to cross tees with side joints centered along main runners and end joints centered along cross tees. Fastened to cross tees with 1 in. long steel gypsum board screws spaced 8 in. OC in the field and 8 in. OC along end joints. Fastened to main runners with 1 in. long gypsum board screws spaced midway between cross tees. Screws along sides and ends of boards spaced 3/8 to 1/2 in. from board edge. End joints of the sheets shall be staggered with spacing between joints on adjacent boards not less than 4 ft OC.

CGC INC — Type C or IP-X2

UNITED STATES GYPSUM CO — Type C or IP-X2

USG BORAL DRYWALL SFZ LLC — Type C

USG MEXICO S A DE C V — Type C or IP-X2

7B. **Gypsum Board*** — For use with Items 3C and 6G. Nom 5/8 in. thick, 48 in. wide gypsum panels installed with long dimension perpendicular to resilient channels. Gypsum panels secured with 1 in. long Type S bugle head steel screws spaced 8 in. OC and located a min of 1/2 in. from side joints and 3 in. from the end joints. Finish Rating with this ceiling system is 20 min.

CGC INC — Type ULIX

UNITED STATES GYPSUM CO — Type ULIX

8. **Finishing System** — (Not Shown) — Vinyl, dry or premixed joint compound, applied in two coats to joints and screw-heads; paper tape, 2 in. wide, embedded in first layer of compound over all joints. As an alternate, nom 3/32 in. thick veneer plaster may be applied to the entire surface of gypsum board. **Alternate Ceiling Membrane** — Not Shown.

9. **Netting** — Fibrous, woven netting material fastened to underside of each joist with staples, with side joints overlapped.

*** Indicates such products shall bear the UL or cUL Certification Mark for jurisdictions employing the UL or cUL Certification (such as Canada), respectively.**

Last Updated on 2024-06-14

The appearance of a company's name or product in this database does not in itself assure that products so identified have been manufactured under UL Solutions' Follow - Up Service. Only those products bearing the UL Mark should be considered to be Certified and covered under UL Solutions' Follow - Up Service. Always look for the Mark on the product.

UL Solutions permits the reproduction of the material contained in Product iQ subject to the following conditions: 1. The Guide Information, Assemblies, Constructions, Designs, Systems, and/or Certifications (files) must be presented in their entirety and in a non-misleading manner, without any manipulation of the data (or drawings). 2. The statement "Reprinted from Product iQ with permission from UL Solutions" must appear adjacent to the extracted material. In addition, the reprinted material must include a copyright notice in the following format: "©2024 UL LLC."

Design/System/Construction/Assembly Usage Disclaimer

- Authorities Having Jurisdiction should be consulted in all cases as to the particular requirements covering the installation and use of UL Certified products, equipment, system, devices, and materials.
- Authorities Having Jurisdiction should be consulted before construction.
- Fire resistance assemblies and products are developed by the design submitter and have been investigated by UL for compliance with applicable requirements. The published information cannot always address every construction nuance encountered in the field.
- When field issues arise, it is recommended the first contact for assistance be the technical service staff provided by the product manufacturer noted for the design. Users of fire resistance assemblies are advised to consult the general Guide Information for each product category and each group of assemblies. The Guide Information includes specifics concerning alternate materials and alternate methods of construction.
- Only products which bear UL's Mark are considered Certified.

BXUV - Fire Resistance Ratings - ANSI/UL 263 Certified for United States

BXUV7 - Fire Resistance Ratings - CAN/ULC-S101 Certified for Canada

[See General Information for Fire-resistance Ratings - ANSI/UL 263 Certified for United States Design Criteria and Allowable Variances](#)

[See General Information for Fire Resistance Ratings - CAN/ULC-S101 Certified for Canada Design Criteria and Allowable Variances](#)

Design No. U303

February 8, 2024

Bearing Wall Rating — 1 Hr

This design was evaluated using a load design method other than the Limit States Design Method (e.g., Working Stress Design Method). For jurisdictions employing the Limit States Design Method, such as Canada, a load restriction factor shall be used — See Guide [BXUV](#) or [BXUV7](#)

*** Indicates such products shall bear the UL or cUL Certification Mark for jurisdictions employing the UL or cUL Certification (such as Canada), respectively.**

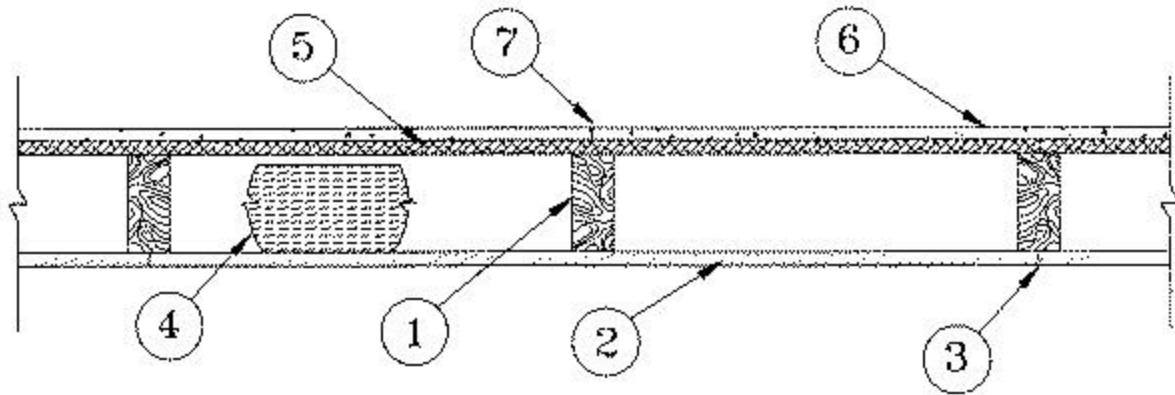

1. **Wood Studs** — Nom 2 by 4 in. spaced 16 in. OC, effectively cross-braced.

2. **Gypsum Board*** — 5/8 in. thick, with square or tapered edges, applied vertically or horizontally with vertical joints centered over studs. Horizontal joints need not be backed by framing. Fastened to studs and plates with 1-7/8 in. long 6d cement coated nails spaced 7 in. OC or with 1-7/8 in. long Type S screws spaced 8 in. OC, or 1-1/4 in. long Type W coarse thread gypsum panel steel screws spaced a max 8 in. OC, with last screw 1 in. from edge of board. 54 in. widths applied horizontally.

CGC INC — Types AR, C, IP-AR, IP-X1, IP-X2, IPC-AR, SCX, ULIX, ULX,WRC, WRX.

UNITED STATES GYPSUM CO — Types AR, C, FRX-G, IP-AR, SCX, IP-X1, IP-X2, IPC-AR, ULIX, ULX, WRC or WRX.

USG BORAL DRYWALL SFZ LLC — Types C, SCX

USG MEXICO S A DE C V — Types AR, C, IP-AR, IP-X1, IP-X2, IPC-AR, SCX, ULX, WRC or WRX.

3. **Joints** — When tapered edge gypsum board is used, joints covered with joint compound and paper tape. As an alternate, gypsum veneer plaster may be applied to the entire surface of Classified veneer baseboard with joints reinforced with paper tape. When square-edge gypsum board is used, treatment of joints is optional.

4. **Batts and Blankets*** — Min 3 in. thick mineral wool batts, friction fit between studs.

THERMAFIBER/OWENS CORNING — Type SAFB, SAFB FF

ROCKWOOL — Type SAFEnSOUND, min. 1.8 pcf.

5. **Sheathing** — Min 15/32 in. thick, 4 ft wide, wood structural panels, min grade "sheathing" applied vertically, with vertical joints centered over studs. Attached to studs with 10d galv nails 6 in. OC at the perimeter and 12 in. OC in the field. Sheathing fully covered with a weather resistive barrier.

6. **Cementitious Backer Units*** — 1/2 or 5/8 in. thick, installed vertically or horizontally over the sheathing with vertical joints centered over studs. All joints offset min 12 in. from underlying sheathing joints. Fastened to studs and plates with corrosion resistant 2-1/4 in. long chamfered, ribbed wafer head screws with a minimum head diameter of .400 inches or 2-1/4 in. hot-dipped galvanized roofing nails spaced 8 in. OC.

UNITED STATES GYPSUM CO — Type DCB.

USG MEXICO S A DE C V — Type DCB.

7. **Joints** — Cement board joints need not be treated.

8. **Vapor Retarder , Water Barrier or Weather Resistive Barrier** — (Optional, not shown) — As required

*** Indicates such products shall bear the UL or cUL Certification Mark for jurisdictions employing the UL or cUL Certification (such as Canada), respectively.**

Last Updated on 2024-02-08

The appearance of a company's name or product in this database does not in itself assure that products so identified have been manufactured under UL Solutions' Follow - Up Service. Only those products bearing the UL Mark should be considered to be Certified and covered under UL Solutions' Follow - Up Service. Always look for the Mark on the product.

UL Solutions permits the reproduction of the material contained in Product iQ subject to the following conditions: 1. The Guide Information, Assemblies, Constructions, Designs, Systems, and/or Certifications (files) must be presented in their entirety and in a non-misleading manner, without any manipulation of the data (or drawings). 2. The statement "Reprinted from Product iQ with permission from UL Solutions" must appear adjacent to the extracted material. In addition, the reprinted material must include a copyright notice in the following format: "©2024 UL LLC."

Design/System/Construction/Assembly Usage Disclaimer

- Authorities Having Jurisdiction should be consulted in all cases as to the particular requirements covering the installation and use of UL Certified products, equipment, system, devices, and materials.
- Authorities Having Jurisdiction should be consulted before construction.
- Fire resistance assemblies and products are developed by the design submitter and have been investigated by UL for compliance with applicable requirements. The published information cannot always address every construction nuance encountered in the field.
- When field issues arise, it is recommended the first contact for assistance be the technical service staff provided by the product manufacturer noted for the design. Users of fire resistance assemblies are advised to consult the general Guide Information for each product category and each group of assemblies. The Guide Information includes specifics concerning alternate materials and alternate methods of construction.
- Only products which bear UL's Mark are considered Certified.

BXUV - Fire Resistance Ratings - ANSI/UL 263 Certified for United States

BXUV7 - Fire Resistance Ratings - CAN/ULC-S101 Certified for Canada

[See General Information for Fire-resistance Ratings - ANSI/UL 263 Certified for United States Design Criteria and Allowable Variances](#)

[See General Information for Fire Resistance Ratings - CAN/ULC-S101 Certified for Canada Design Criteria and Allowable Variances](#)

Design No. U341

January 31, 2024

Bearing Wall Rating — 1 Hr.

Finish Rating — Min 20 min.

This design was evaluated using a load design method other than the Limit States Design Method (e.g., Working Stress Design Method). For jurisdictions employing the Limit States Design Method, such as Canada, a load restriction factor shall be used — See Guide [BXUV](#) or [BXUV7](#)

*** Indicates such products shall bear the UL or cUL Certification Mark for jurisdictions employing the UL or cUL Certification (such as Canada), respectively.**

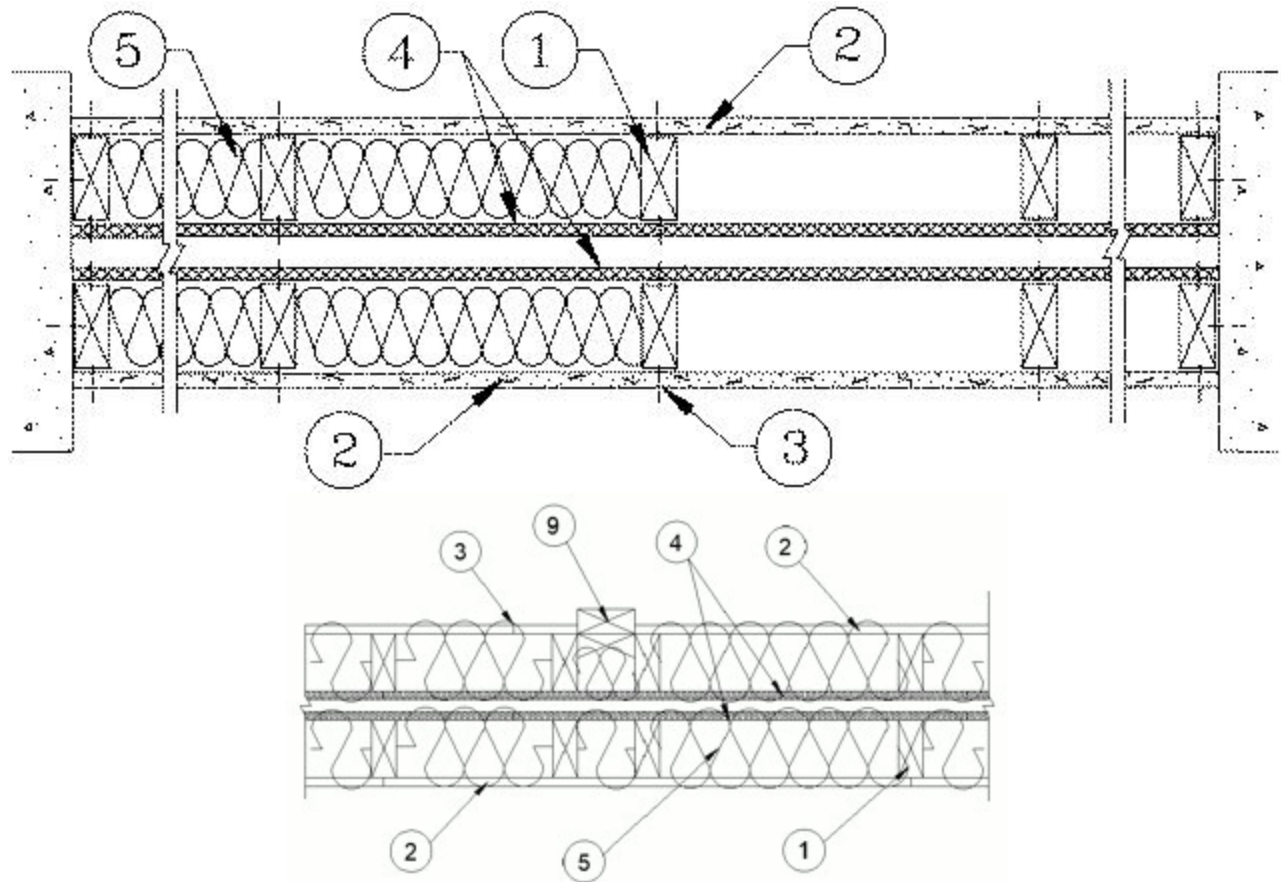

HORIZONTAL SECTION

1. **Wood Studs** — Nom 2 by 4 in., spaced 24 in. OC max. Cross braced at mid-height and effectively firestopped at top and bottom of wall. No min. air space between stud rows except to accommodate attachment of sheathing, where required. See items 4 and 5.

2. **Gypsum Board*** — Any 5/8 in. thick UL Classified Gypsum Board that is eligible for use in Design Nos. L501, G512 or U305.

Nom 5/8 in. thick 4 ft wide. Gypsum board applied horizontally or vertically, unless specified below, and nailed to studs and bearing plates 7 in. OC with 6d cement coated nails, 1-7/8 in. long, 0.0915 in. shank diam and 1/4 in. diam head. As an alternate, No. 6 bugle head drywall screws, 1-7/8 in. long, may be substituted for the 6d cement coated nails.

When **Steel Framing Members*** (Item 6 or any alternate clips) are used, wallboard attached to furring channels with 1 in. long Type S bugle-head steel screws spaced 12 in. OC.

When used in widths other than 48 in., gypsum board to be installed horizontally.

AMERICAN GYPSUM CO ([View Classification](#)) — CKNX.R14196

BEIJING NEW BUILDING MATERIALS PUBLIC LTD CO ([View Classification](#)) — CKNX.R19374

CABOT MANUFACTURING ULC ([View Classification](#)) — CKNX.R25370

CERTAINTED GYPSUM INC ([View Classification](#)) — CKNX.R3660

CGC INC ([View Classification](#)) — CKNX.R19751

CERTAINTED GYPSUM INC ([View Classification](#)) — CKNX.R18482

GEORGIA-PACIFIC GYPSUM L L C ([View Classification](#)) — CKNX.R2717

NATIONAL GYPSUM CO ([View Classification](#)) — CKNX.R3501

PABCO BUILDING PRODUCTS L L C, DBA PABCO GYPSUM ([View Classification](#)) — CKNX.R7094

PANEL REY S A ([View Classification](#)) — CKNX.R21796

SIAM GYPSUM INDUSTRY (SARABURI) CO LTD ([View Classification](#)) — CKNX.R19262

THAI GYPSUM PRODUCTS PCL ([View Classification](#)) — CKNX.R27517

UNITED STATES GYPSUM CO ([View Classification](#)) — CKNX.R1319

USG BORAL DRYWALL SFZ LLC ([View Classification](#)) — CKNX.R38438

USG BORAL DRYWALL SFZ LLC ([View Classification](#)) — CKNX.R38438

USG MEXICO S A DE C V ([View Classification](#)) — CKNX.R16089

2A. **Gypsum Board*** — (As an alternate to Item 2, not shown) — Nominal 5/8 in. thick, 4 ft wide panels, applied vertically to studs and bearing plates on one side of the assembly with 1-5/8 in. long Type S screws spaced 12 in. OC at perimeter of panels and 8 in. OC in the field. Horizontal joints of vertically applied panels need not be backed by studs. Panel joints covered with paper tape and two layers of joint compound. Screwheads covered with two layers of joint compound. Batts and Blankets placed in stud cavity as described in Item 5C. Not evaluated for use with Steel Framing Members, Furring Channels or Fiber, Sprayed.

PABCO BUILDING PRODUCTS L L C, DBA PABCO GYPSUM — Type QuietRock QR-530 (finish rating 23 min).

2B. **Gypsum Board*** — (As an alternate to Item 2, not shown) — Any 5/8 in. thick gypsum panels that are eligible for use in Design Nos. L501, G512 or U305, supplied by the Classified companies listed below shown in the **Gypsum Board*** (CKNX) category. Applied horizontally or vertically and attached to studs and bearing plates with 1-1/4 in. long Type W coarse thread gypsum panel steel screws spaced a max 8 in. OC, with last screw 1 in. from edge of board. When used in widths other than 48 in., gypsum board to be installed horizontally.

UNITED STATES GYPSUM CO

USG BORAL DRYWALL SFZ LLC

USG MEXICO S A DE C V

2C. **Gypsum Board*** — (As an alternate to Item 2, Not Shown) — 5/8 in. thick gypsum panels applied horizontally or vertically and attached to studs and bearing plates with 1-1/4 in. long Type W coarse thread gypsum panel steel screws spaced a max 8 in. OC, with last screw 1 in. from edge of board. When used in widths other than 48 in., gypsum board to be installed horizontally.

AMERICAN GYPSUM CO — Types AGX-1, M-Glass, AG-C, LightRoc

CERTAINTED GYPSUM INC — Type C or Type X-1

NATIONAL GYPSUM CO — Type FSK, Type FSK-G, Type FSW, Type FSW-3, Type FSW-5, Type FSW-G, Type FSK-C, Type FSW-C, Type FSMR-C, Type FSW-6, Type FSL

THAI GYPSUM PRODUCTS PCL — Type C or Type X

2D. **Gypsum Board*** — (As an alternate to Items 2, 2A, 2B and 2C) — 5/8 in. thick gypsum panels, with square edges, applied either horizontally or vertically. Gypsum panels fastened to framing with 1-1/4 in. long Type W coarse thread gypsum panel steel screws spaced a max 8 in. OC, with last 2 screws 1 and 4 in. from edge of board or nailed as described in Item 2. When used in widths of other than 48 in., gypsum boards are to be installed horizontally.

GEORGIA-PACIFIC GYPSUM L L C — GreenGlass Type X, Type DGG.

2E. **Gypsum Board*** — (As an alternate to Items 2 through 2D) — 5/8 in. thick, 4 ft. wide, paper surfaced applied vertically only and secured as described in Item 2.

GEORGIA-PACIFIC GYPSUM L L C — Type X ComfortGuard Sound Deadening Gypsum Board.

2F. **Gypsum Board*** — (As an alternate to Items 2 through 2E) - Installed as described in Item 2. 5/8 in. thick, 4 ft. wide, paper surfaced, applied vertically only and fastened to the studs and plates with 6d cement coated nails 1-7/8 in. long, 0.0915 in. shank diam and 1/4 in. diam heads, 7 in. OC. Not for use with item #6.

NATIONAL GYPSUM CO — Type SBWB

2G. **Gypsum Board*** — (As an alternate to Items 2 through 2F) — Nominal 5/8 in. thick, 4 ft wide panels, applied vertically and secured as described in Item 2.

PABCO BUILDING PRODUCTS L L C, DBA PABCO GYPSUM — Types QuietRock ES.

2H. **Gypsum Board*** — (As an alternate to Items 2 through 2G) — Installed as described in Item 2. 5/8 in. thick, 4 ft. wide, paper surfaced, applied vertically or horizontally fastened to the studs and plates with 1-1/4 in. long Type W coarse thread gypsum panel steel screws spaced a max 12 in. OC.

CERTAINTED GYPSUM INC — Type SilentFX

2I. **Wall and Partition Facings and Accessories*** — (As an alternate to Items 2 through 2H) — Nominal 5/8 in. thick, 4 ft wide panels, applied vertically and secured as described in Item 2.

PABCO BUILDING PRODUCTS L L C, DBA PABCO GYPSUM — Type QuietRock 527.

2J. **Gypsum Board*** — (As an alternate to 5/8 in. Type FSW in Item 2) — 2 layers nom. 5/16 in. thick gypsum panels applied vertically or horizontally. Horizontal joints on the same side need not be staggered. Inner layer attached with fasteners, as described in item 2, spaced 24 in. OC. Outer layer attached per Item 2.

NATIONAL GYPSUM CO — Type FSW.

2K. **Gypsum Board*** — (As an alternate to Item 2) — 5/8 in. thick gypsum panels, with beveled, square, or tapered edges, applied either horizontally or vertically. Gypsum panels fastened to framing with 1-1/4 in. long Type W coarse thread gypsum panel steel screws spaced a maximum 10 in. OC with the last two screws 4 and 1 in. from the edges of the board. When used in widths other than 48 in., gypsum panels are to be installed horizontally.

CERTAINTED GYPSUM INC — Type LGFC6A (finish rating 21 min), Type LGFC2A, Type LGFC-C/A, Type LGFC-WD, Type LGLLX

3. **Joints and Nailheads** — Gypsum board joints of outer layer covered with tape and joint compound. Nail heads of outer layer covered with joint compound. As an alternate, nom 3/32 in. thick gypsum veneer plaster may be applied to the entire surface of Classified veneer baseboard with joints reinforced with paper tape.

4. **Sheathing** — (Optional) — Septum may be sheathed with min 7/16 in. thick wood structural panels min grade "C-D" or "Sheathing" or min 1/2 in. thick **Mineral and Fiber Boards***.

See **Mineral and Fiber Boards** (CERZ) category for names of Classified companies.

5. **Batts and Blankets*** — 3-1/2 in. max thickness glass or mineral fiber batt insulation. **Optional** when sheathing (Item 4) is used on both halves of wall.

See **Batts and Blankets** (BZJZ) category for list of Classified companies.

5A. **Fiber, Sprayed*** — As an alternate to Batts and Blankets (Item 5) — Spray applied cellulose material. The fiber is applied with water to completely fill the enclosed cavity in accordance with the application instructions supplied with the product with a nominal dry density of 2.7 lb/ft³. Alternate Application Method: The fiber is applied without water or adhesive at a nominal dry density of 3.5 lb/ft³, in accordance with the application instructions supplied with the product.

Applegate Greenfiber Acquisition LLC — Insulmax and SANCTUARY for use with wet or dry application.

5B. **Fiber, Sprayed*** — As an alternate to Batts and Blankets (Item 5) when Sheathing (Item 4) is used on both halves of wall - Spray applied cellulose insulation material. The fiber is applied with water to interior surfaces in accordance with the application instructions supplied with the product. Applied to completely fill the enclosed cavity. Minimum dry density of 4.3 pounds per cubic ft.

NU-WOOL CO INC — Cellulose Insulation

5C. **Batts and Blankets*** — (Required for use with Wall and Partition Facings and Accessories, Item 2A. Use of Sheathing, Item 4, does not nullify requirement of Item 5C for use with Item 2A) — Glass fiber insulation, nom 3-1/2 in. thick, min. density of 0.80 pcf, with a flame spread of 25 or less and a smoke developed of 50 or less, friction-fitted to completely fill the stud cavities. See Batts and Blankets Category (BKNV) for names of manufacturers.

5D. **Fiber, Sprayed*** — As an alternate to Batts and Blankets (Item 5) and Item 5A when Sheathing (Item 4) is used on both halves of wall - Spray applied cellulose fiber. The fiber is applied with water to completely fill the enclosed cavity in accordance with the application instructions supplied with the product. The minimum dry density shall be 4.30 lbs/ft³.

INTERNATIONAL CELLULOSE CORP — Celbar-RL

5E. **Fiber, Sprayed*** — As an alternate to Batts and Blankets (Item 5) - Spray-applied cellulose material. The fiber is applied with water to completely fill the enclosed cavity in accordance with the application instructions supplied with the product. To facilitate the installation of the material, any thin, woven or non-woven netting may be attached by any means possible to the outer face the studs. The material shall reach equilibrium moisture content before the installation of materials on either face of the studs. The minimum dry density shall be 5.79 lbs/ft³.

Applegate Greenfiber Acquisition LLC— Applegate Advanced Stabilized Cellulose Insulation

6. **Steel Framing Members*** — (Optional, Not Shown) — Furring channels and Steel Framing Members as described below:

A. **Furring Channels** — Formed of No. 25 MSG galv steel. 2-9/16 in. or 2-23/32 in. wide by 7/8 in. deep, spaced 24 in. OC perpendicular to studs. Channels secured to studs as described in Item b. Ends of adjoining channels are overlapped 6 in. and tied together with double strand of No. 18 SWG galv steel wire near each end of overlap. As an alternate, ends of adjoining channels may be overlapped 6 in. and secured together with two self-tapping #6 framing screws, min. 7/16 in. long at the midpoint of the overlap, with one screw on each flange of the channel. Wallboard attached to furring channels as described in Item 2.

B. **Steel Framing Members*** — Used to attach furring channels (Item a) to studs (Item 1) . Clips spaced 48 in. OC., and secured to studs with No. 8 x 2-1/2 in. coarse drywall screw through the center grommet. Furring channels are friction fitted into clips. RSIC-1 clip for use with 2-9/16 in. wide furring channels. RSIC-1 (2.75) clip for use with 2-23/32 in. wide furring channels.

PAC INTERNATIONAL L L C — Types RSIC-1, RSIC-1 (2.75).

6A. **Steel Framing Members*** — (Optional, Not Shown, As an alternate to Item 6) — Furring channels and Steel Framing Members as described below:

a. **Furring Channels** — Formed of No. 25 MSG galv steel. 2-3/8 in. wide by 7/8 in. deep, spaced 24 in. OC perpendicular to studs. Channels secured to studs as described in Item b. Ends of adjoining channels are overlapped 6 in. and tied together with double strand of No. 18 SWG galv steel wire near each end of overlap. As an alternate, ends of adjoining channels may be overlapped 6 in. and secured together with two self-tapping #6 framing screws, min. 7/16 in. long at the midpoint of the overlap, with one screw on each flange of the channel. Gypsum board attached to furring channels as described in Item 2.

b. **Steel Framing Members*** — Used to attach furring channels (Item a) to studs. Clips spaced 48 in. OC. Genie clips secured to studs with No. 8 x 1-1/2 in. coarse drywall screw through the center hole. Furring channels are friction fitted into clips.

PLITEQ INC — Type Genie Clip

6B. **Steel Framing Members*** — (Optional, Not Shown, As an alternate to Item 6) — Furring channels and Steel Framing Members as described below:

a. **Furring Channels** — Formed of No. 25 MSG galv steel. Spaced 24 in. OC perpendicular to studs. Channels secured to studs as described in Item b. Ends of adjoining channels overlapped 6 in. and tied together with double strand of No. 18 AWG galvanized steel wire. Gypsum board attached to furring channels as described in Item 2.

b. **Steel Framing Members*** — Used to attach furring channels (Item 6Ba) to studs. Clips spaced 48 in. OC., and secured to studs with 2 in. coarse drywall screw with 1 in. diam washer through the center hole. Furring channels are friction fitted into clips.

STUDCO BUILDING SYSTEMS — RESILMOUNT Sound Isolation Clips - Type A237R

6C. **Steel Framing Members*** — (Optional, Not Shown, As an alternate to Item 6) — Furring channels and Steel Framing Members as described below:

A. **Furring Channels** — Formed of No. 25 MSG galv steel. Spaced 24 in. OC perpendicular to studs. Channels secured to studs as described in Item 6Cb. Ends of adjoining channels overlapped 6 in. and tied together with double strand of No. 18 AWG galvanized steel wire. Gypsum board attached to furring channels as described in Item 2.

B. **Steel Framing Members*** — Used to attach furring channels (Item 6CA) to studs. Clips spaced 48 in. OC., and secured to studs with No. 8 x 2-1/2 in. coarse drywall screw through the center hole. Furring channels are friction fitted into clips.

REGUPOL AMERICA — Type SonusClip

6D. **Steel Framing Members*** — (Optional, Not Shown, As an alternate to Item 6) — Resilient channels and Steel Framing Members as described below:

a. **Resilient Channels** — Formed of No. 25 MSG galv steel, spaced 24 in. OC, and perpendicular to studs. Channels secured to studs as described in Item b. Ends of adjoining channels overlapped 6 in. and secured in place with two No. 8 15 x 1/2 in. Philips Modified Truss screws spaced 2-1/2 in. from the center of the overlap. Gypsum board attached to resilient channels as described in Item 2.

b. **Steel Framing Members*** — Used to attach resilient channels (Item 6Da) to studs. Clips spaced 48 in. OC., and secured to studs with No. 8 x 2-1/2 in. coarse drywall screw through the center hole. Resilient channels are secured to clips with one No. 10 x 1/2 in. pan-head self-drilling screw.

KEENE BUILDING PRODUCTS CO INC — Type RC+ Assurance Clip

6E. **Steel Framing Members*** — (Optional, Not Shown) — Resilient channels and Steel Framing Members as described below:

a. **Resilient Channels** — Formed of No. 25 MSG galv steel, spaced 24 in. OC, and perpendicular to studs. Channels secured to studs as described in Item b. Gypsum board attached to resilient channels as described in Item 2.

b. **Steel Framing Members*** - Used to attach resilient channels to wall studs. A resilient sound isolation accessory shall be used at each attachment point of the resilient channels to the studs. Channel ends butted and centered under the structural members and attached with one accessory at each end. Additional accessories used to hold resilient channels that support the gypsum board end joints. The accessory envelops the mounting edge of the resilient channel. The accessory and resilient channel are fastened to the studs with the screws supplied with the accessory and per the accessory manufacturer's installation instructions.

PAC INTERNATIONAL L L C — Type RC-1 Boost

6F **Steel Framing Members*** — (Optional, Not Shown, As an alternate to Item 6) — Furring channels and Steel Framing Members as described below:

a **Furring Channels** — Formed of No. 25 MSG galv steel. 2-23/32 in. wide by 7/8 in. deep, spaced 24 in. OC perpendicular to studs. Channels secured to studs as described in Item b. Ends of adjoining channels are overlapped 6 in. and tied together with double strand of No. 18 SWG galv steel wire near each end of overlap. As an alternate, ends of adjoining channels may be overlapped 6 in. and secured together with two self-tapping #6 framing screws, min. 7/16 in. long at the midpoint of the overlap, with one screw on each flange of the channel. Gypsum board attached to furring channels as described in Item 2.

b **Steel Framing Members*** — Used to attach furring channels (Item 6Fa) to studs. Clips spaced maximum 48 in. OC. Clips secured to studs with No. 8 x 2-1/2 in. coarse drywall screw through the center grommet. Furring channels are friction fitted into clips.

CLARKDIETRICH BUILDING SYSTEMS — Type ClarkDietrich Sound Clip

7. **Wall and Partition Facings and Accessories*** — (Optional, Not shown) — Nominal 1/2 in. thick, 4 ft wide panels, for optional use as an additional layer on one or both sides of the assembly. Panels attached in accordance with manufacturer's recommendations. When the QR-500 or QR-510 panel is installed between the wood framing and the UL Classified gypsum board, the required UL Classified gypsum board layer(s) is/are to be installed as indicated as to fastener type and spacing, except that the required fastener length shall be increased by a minimum of 1/2 in. Not evaluated or intended as a substitute for the required layer(s) of UL Classified Gypsum Board.

PABCO BUILDING PRODUCTS L L C, DBA PABCO GYPSUM — Type QuietRock QR-500 and QR-510

8. **Mineral and Fiber Board*** — ((Optional, Not Shown) — For optional use as an additional layer on one or both sides of wall. Nom 1/2 in. thick, 4 ft wide with long dimension parallel and centered over studs. Attached to framing as described in Item 2. The required UL Classified gypsum board layer(s) is/are to be installed as indicated as to fastener type and spacing, except that the required fastener length shall be increased by a minimum of 1/2 in. Not evaluated or intended as a substitute for the required layer(s) of UL Classified Gypsum Board.

HOMASOTE CO — Homasote Type 440-32

9. **Non-Bearing Wall Partition Intersection** — (Optional) — Two nominal 2 by 4 in. stud or nominal 2 by 6 in. stud nailed together with two 3in. long 10d nails spaced a max. 16 in. OC. vertically and fastened to one side of the minimum 2 by 4 in. stud with 3 in. long 10d nails spaced a max 16 in. OC. vertically. Intersection between partition wood studs to be flush with the 2 by 4 in. studs. The wall partition wood studs are to be framed by with a second 2 by 4 in. wood stud fastened with 3 in. long 10d nails spaced a max. 16 in. OC. vertically. Maximum one non-bearing wall partition intersection per stud cavity. Non-bearing wall partition stud depth shall be at a minimum equal to the depth of the bearing wall.

(Optional, Not Shown) Alternate Construction For Use On One Side Of The Wall.

10. **Mineral and Fiber Board*** — For use with Items 10A-10D) —Nom 1/2 in. thick, 4 ft wide with long dimension parallel and centered over studs. Attached to framing with minimum 1-3/8 in. long ring shanked nails or 1-1/4 in. long Type W steel screws, spaced 12 in. OC along board edges and 24 in. OC in field of board along intermediate framing. Not evaluated or intended as a substitute for the required layer(s) of UL Classified Gypsum Board.

HOMASOTE CO — Homasote Type 440-32

10A. **Glass Fiber Insulation** — (For use with Item 10) — 3-1/2 in. thick glass fiber batts bearing the UL Classification Marking as to Surface Burning and/or Fire Resistance, placed to fill the interior of the wall. See Battis and Blankets (BKNV or BZJZ) categories for names of Classified companies.

10B. **Batts and Blankets*** — (As an alternate to Item 10B, For use with Item 10), 3 in. thick mineral wool batts, placed to fill interior of wall, attached to the 3-1/2 in. face of the studs with staples placed 24 in. OC.

THERMAFIBER/OWENS CORNING — Type SAFB, SAFB FF

10C. **Adhesive** — (For use with Item 10) — Construction grade adhesive applied in vertical, serpentine, nominal 3/8 in. wide beads down the length of both vertical edges of Mineral and Fiber Board (Item 14A).

10D. **Gypsum Board*** — (For use with Item 10) — 5/8 in. thick, 4 ft wide, applied vertically over Mineral and Fiber Board (Item 14A) with vertical joints located anywhere over stud cavities. Secured to mineral and fiber boards with 1-1/2 in. Type G Screws spaced 8 in. OC along edges of each vertical joint and 12 in. OC in intermediate field of the Mineral and Fiber Board (Item 10). Secured to outermost studs and bearing plates with 2 in. long Type S screws spaced 8 in. OC. Gypsum Board joints covered with paper tape and joint compound. Screw heads covered with joint compound. Finish Rating 30 Min.

AMERICAN GYPSUM CO — Type AG-C

CERTAINTED GYPSUM INC — Type C

CERTAINTED GYPSUM INC — Type LGFC-C/A

GEORGIA-PACIFIC GYPSUM L L C — Types 5, DAPC, TG-C

NATIONAL GYPSUM CO — Types FSK-C, FSW-C

PABCO BUILDING PRODUCTS L L C, DBA PABCO GYPSUM — Type PG-C

PANEL REY S A — Type PRC

THAI GYPSUM PRODUCTS PCL — Type C

UNITED STATES GYPSUM CO —Types C, IP-X2, IPC-AR

USG BORAL DRYWALL SFZ LLC — Type C

USG MEXICO S A DE C V — Types C, IP-X2, IPC-AR

*** Indicates such products shall bear the UL or cUL Certification Mark for jurisdictions employing the UL or cUL Certification (such as Canada), respectively.**

Last Updated on 2024-01-31

The appearance of a company's name or product in this database does not in itself assure that products so identified have been manufactured under UL Solutions' Follow - Up Service. Only those products bearing the UL Mark should be considered to be Certified and covered under UL Solutions' Follow - Up Service. Always look for the Mark on the product.

UL Solutions permits the reproduction of the material contained in Product iQ subject to the following conditions: 1. The Guide Information, Assemblies, Constructions, Designs, Systems, and/or Certifications (files) must be presented in their entirety and in a non-misleading manner, without any manipulation of the data (or drawings). 2. The statement "Reprinted from Product iQ with permission from UL Solutions" must appear adjacent to the extracted material. In addition, the reprinted material must include a copyright notice in the following format: "©2024 UL LLC."

List of Drawings

APARTMENTS

General

	Cover & Sheet Index	FH	Fair Housing
CFP1	Code Footprint	UFAS1	Uniform Federal Accessibility Standards
CFP2	Code Footprint	UFAS2	Uniform Federal Accessibility Standards
ADA	ADA Diagrams	UFAS3	Uniform Federal Accessibility Standards

Civil

Submitted under separate permit

Architectural

A1.1	Site Plan	A3.2	Building B - Exterior Elevations
A1.2	Enlarged Plans & Details	A3.3	Enlarged Entry Elevations
A1.3	Enlarged Plans & Details	A4.1	Typical Wall Sections
A1.4	Sections	A4.2	Typical Wall Sections
A1.5	Sections	A4.3	Typical Wall Sections
L1.1	Landscaping Plan	A4.4	Details
A2.1	Building A & Clubhouse Floor Plans	A4.5	Details
A2.2	Building B Floor Plans	A4.6	Entry Sections & Details
A2.3	2-Bedroom Unit Plans	A4.7	Clubhouse Sections & Details
A2.4	3-Bedroom Unit Plans	A4.8	Clubhouse Sections & Details
A2.5	Accessible/Type-B Enlarged Bathroom Plans & Schedules	A4.9	Fire Penetration Details
A2.6	Standard Enlarged Bathroom Plans	A4.10	Manufacturer Details – Stone Veneer
A2.7	Accessible Interior Elevations	A4.11	Manufacturer Details – Lap Siding
A2.8	Standard/Type-B Interior Elevations	A4.12	Manufacturer Details – Board & Batten Siding
A2.9	Casework Details	A5.1	Roof Plans
A2.10	clubhouse Plan and Schedules	A5.2	Roof and Stair Details
A2.11	Clubhouse Enlarged Plans & Details	A6.1	Stair Section and Enlarged Plans
A3.1	Building A - Exterior Elevations	A7.1	Apartments – Reflected Ceiling Plans

Structural

S001	General Notes and Specifications	S121	Building B Level 1
S002	General Notes and Specifications	S122	Building B Level 2 & 3
S003	Special Inspections	S123	Building B Roof
S004	Schedules	S500	Typical Wood Details
S110	Building A Foundation	S510	Framing Details
S111	Building A Level 1	S511	Framing Details
S112	Building A Level 2 & 3	S520	Roof Details
S113	Building A Roof	S530	Shear Wall Details
S120	Building B Foundation		

Mechanical

ME1.1	Building B - M/E Plans	ME1.4	Clubhouse - Lighting and Power Plans
ME1.2	Building A - M/E Plans	M4.1	Apartment Unit Mechanical Plans
ME1.3	Clubhouse - HVAC & Domestic Water Plans	M6.1	Mechanical Schedules & Details

Plumbing

P1.1	Building B – Under Floor/First Floor Waste & Vent	P4.1	Apartment Unit Plumbing Plans
P1.2	Building B – Second/Third Floor Waste & Vent	P5.1	Waste & Vent Isometric Diagrams
P1.3	Building A – Under Floor/First Floor Waste & Vent Plan	P5.2	Domestic Water Riser Diagrams
P1.4	Building A – Second/Third Floor Waste & Vent Plans	P6.1	Plumbing Schedules & Details

Electrical

E1.0	Electrical Site Plan & Details	E6.3	Electrical Panel Schedules
E4.1	Apartment Unit Electrical Plans	E7.1	Photometric Site Plan
E6.1	Electrical Schedules & Details	E7.2	Exterior Light Fixture Schedules & Specifications
E6.2	Electrical Schedules & Riser Diagrams		

SECTION 01010

GENERAL WORK REQUIREMENTS

1. GENERAL

Should conflict occur between these General Work Requirements and the General Conditions, the requirements of this Section take precedence.

2. INTENT OF DOCUMENTS

The Contract Drawings are complementary and what is called for by anyone shall be as binding as if called by all. The intention of the documents is to include all labor and materials, equipment and transportation necessary for the proper execution of the work.

3. MANUFACTURERS' DIRECTIONS

All manufactured articles, materials and equipment shall be applied, installed, connected, erected, used, cleaned and conditioned as directed by the manufacturers, unless herein specified to the contrary.

4. COOPERATION - CONTRACTOR WITH OWNER

It shall be clearly understood that the Owner reserves the right to install various equipment in the building prior to completion and acceptance, and it shall be the duty of the Contractor to cooperate with the Owner's employees rendering such assistance and so arranging his work that the entire project will be delivered complete in the best possible condition when required.

5. BUILDING PERMIT

As stated in Subparagraph 4.7.1, AIA DOCUMENT A201, General Conditions, the General Contractor shall secure and pay for the building permit.

6. CONSTRUCTION COORDINATION

Before starting construction, a meeting shall be held with Contractor(s), Architect, and Consulting Engineers in attendance to plan and coordinate the schedule of construction and to review intent of Contract Documents. Contractor(s) shall follow instructions received at meeting in prosecuting the Work.

7. MATERIALS - EQUIPMENT - SUBSTITUTION

- a. In general, these Specifications identify the required materials and equipment by naming one or more manufacturers, brand, model, catalog number, and/or other identification; the first-named manufacturer's product used as a basis for design; the other named brands considered equivalent. Equivalent brand manufacturers named must furnish products consistent with the Specifications for the first-named product, as determined by the Architect. Base Bid shall include only those brands named and must be used on the project, except as hereinafter provided.
- b. Hazardous Materials are prohibited from this project and any equipment specified. All materials, systems, and or equipment must not contain hazardous materials in excess of the US EPA criteria.
- c. Materials or equipment specified exclusively, Base Bid shall be based on same and used on project, except as hereinafter provided.
- d. Prior to receipt of bids, should Contractor wish to incorporate in Base Bid, brands or products other than those named in the Specifications, he shall submit written request for substitution to Architect not later than seven (7) days prior to date bids are due. Architect will consider request and items approved will be listed in an addendum issued to all bidders.

- e. After execution of Contract, substitution of product brands for those named in the Specifications will be considered, only if request is received within thirty (30) days after Contract Date and request includes showing credit due Owner.
 - f. Materials specified equivalent and those proposed for substitution must be equal or better than first-named material in construction, efficiency, utility, aesthetic design, physical size shall not be larger than space provided for it. Request for substitution by full description and technical data in two (2) copies, including manufacturer's name, model, catalog number, photographs or cuts, physical dimensions, operating characteristics, and any other information for comparison.
 - g. Owner reserves the right:
 - 1) To require any or all bidders, before execution of Contract, to state what materials they will use.
 - 2) To require "if bound with the Bid Form," the Contractor to fill out a BID SUPPLEMENT listing the BASE BID and "ADD" or "DEDUCT" for other materials he proposes to use.
8. APPROVAL OF SUBCONTRACTORS - MATERIALS
- a. The Contractor, if requested, must submit for approval before signing Agreement, list of Subcontractors and material suppliers enumerating items of work to be performed, name of materials, equipment, etc., to be furnished and/or installed. Refer to Paragraph - MATERIALS - EQUIPMENT - SUBSTITUTION.
 - b. If the list is not requested prior to signing of Agreement, list, as described in previous paragraph, shall be furnished within ten (10) days of signing Agreement.
9. PROTECTION - Supplement, ARTICLE 10, AIA GENERAL CONDITIONS
- a. Refer to Paragraph - WEATHER CONDITIONS.
 - b. Each Contractor shall assume responsibility for his materials stored on the premises.
 - c. General Contractor shall take charge and assume general responsibility for proper protection of project during construction.
 - d. The General Contractor shall protect trees, shrubs, lawns and all landscape from damage, providing guards and covering. Damaged work shall be repaired or replaced at his expense. Protect streets and sidewalks and make repairs at his expense.
 - 1) Water Protection. The General Contractor shall, at all times, protect the excavation, trenches, and/or the building from damage by rain water, spring water, ground water, backing up of drains or sewers and all other water. He shall provide all pumps and equipment and enclosures to provide this protection.
 - 2) Temporary Drainage. The General Contractor shall construct and maintain all necessary temporary drainage and do all pumping necessary to keep the excavation free of water.
 - 3) Snow and Ice. The General Contractor shall remove all snow and ice from public sidewalks and from the building, as may be required for the proper protection and/or prosecution of the Work.
 - 4) Bracing, Shoring, and Sheeting. The General Contractor shall provide all shoring, bracing and sheeting as required for safety and for the proper execution of the work and have same removed when the work is completed.
 - 5) Guard Lights. The General Contractor shall provide and maintain guard lights at all barricades, railings, obstructions in the streets, roads or sidewalks and at all trenches or pits adjacent to public walks or roads.
 - 6) Weather Conditions. The General Contractor shall, at all times, provide protection against weather; rain, winds, storms, frost, or heat, so as to maintain all work, materials, apparatus, and fixtures, free from injury or damage. At the end of the day's work, all new work likely to be damaged shall be covered.
10. WEATHER CONDITIONS
- The Contractor shall protect all portions of his work and all materials, at all times from damage by water, freezing, frost and is to repair, replace and make good to the satisfaction of the Architect, any portion of same which may in the Architect's opinion, have been damaged by the elements.

11. GRADES, LINES, LEVELS, AND SURVEYS

The Owner will establish the lot lines, restrictions and a bench mark. All other grades, lines, levels, and bench marks shall be established and maintained by the General Contractor, who shall be responsible for same. The General Contractor shall verify all grades, lines, levels, and dimensions as shown on the Drawings and he shall report all errors or inconsistencies in the above to the Architect before commencing work.

- a. The General Contractor shall provide and maintain well-built batter boards at all corners. He shall establish bench marks in not less than two (2) widely separated places. As the work progresses, he shall establish bench marks at each floor, giving exact levels of the various floors.
- b. As the work progresses, the General Contractor shall lay out in the forms and the rough flooring the exact location of all partitions as a guide to all trades.
- c. The General Contractor shall verify all grades, lines, levels, and dimensions as shown on the Drawings and he shall report any errors or inconsistencies in the above to the Architect before commencing work.

12. USE OF COMPLETED PORTIONS

The Owner reserves the right to take possession of and use any completed or partially completed portions of the building, and further reserves the right to install equipment and facilities which are not a part of the Contract, notwithstanding the fact that the time of completion of entire work or portions thereof may not have expired; but such taking possession or installation of facilities shall not be deemed an acceptance of any work not completed in accordance with the Contract Documents. The Owner, in taking possession of completed portions or installing such equipment, and facilities, shall do so at his own expense any damage which may occur either directly or indirectly by reason of such action.

- a. Building Completion-Occupancy. Owner reserves the right to occupy building when the time for completion of work as stipulated in Contract has been reached, even though all parts of the work have not been completed and accepted by Owner. All work, including heating, electrical, and water service, will be discontinued only to Owner schedule.
- b. Limit of Contract is not confined to any particular area of the site, but includes any area required to perform work shown on the Drawings and/or specified in these Specifications.

13. REQUIREMENTS IMMEDIATELY AFTER EXECUTION OF CONTRACT

Immediately after execution of the Contract, the Contractor shall deliver to the Architect the following items which are described more fully in following Articles:

Schedule of Values
Schedule of Operations
Progress Charts
Samples
Superintendent's name and resume of experience
List of Subcontractors and Material Suppliers

- a. Schedule of Values on AIA Form G702, or other form approved by the Architect, a detailed breakdown of the Contract Sum indicating the amounts allotted to the various divisions of the work for labor and material. The schedule will serve as a guide to the Architect in determining the amounts due each month as the work progresses. The schedule shall be broken down as directed by the Architect.
- b. Schedule of Operations based on the above Schedule of Values and indicating the progress of the work up to the first day of each month shall be prepared by the Contractor in a form approved by the Architect and shall be delivered to the Architect in duplicate with each application for payment.
- c. Progress Charts based on the above specified schedule of operations and indicating the progress of the work up to the first day of each month shall be prepared by the Contractor in a form approved by the Architect and shall be delivered to the Architect in duplicate with each application for payment. Progress charts shall be in the form of a bar graph. Along with progress charts the Contractor shall provide an estimated monthly cash flow chart.

14. CONSTRUCTION PROCEDURE

- a. Each Contractor shall schedule his work so as to cause a minimum of interference with business operations during all of the construction work.
- b. In-Use Areas. Construction work within areas immediately adjacent to existing in-use areas shall be coordinated with the Owner, so that work is accomplished during periods of light occupancy of the areas and cause the least disturbance. Work shall be executed by methods that will create the least amount of noise. Work shall be prefabricated when practical to do so. New facilities shall be ready for use prior to disturbing existing areas.
- c. Precautions and Cooperation
 - 1) Notify the Owner 7 days in advance before any utility (natural gas, water, electricity, or sewer) is to be interrupted.
 - 2) With proper notification, interruption in utilities up to 4 hours will be permitted without special provisions by the Contractor. *If any interruption of a utility exceeds 4 hours the Contractor must make arrangements for temporary alternate utility service.
 - 3) Interruption of utilities must be coordinated with the Owner with changeovers and out of service at night. Weekend and evening changeovers of utilities shall occur with no additional cost to the Owner.

15. TIME EXTENSIONS ADVERSE WEATHER

- a. The Contractor shall comply with all provisions of the General Conditions in submitting any request for extension of Contract Time due to unusually severe weather.
- b. Definitions:
 - 1. Adverse Weather - Atmospheric conditions at a definite time and place which are unfavorable to construction activities.
 - 2. Unusually Severe Weather - Weather which is more severe than the adverse weather anticipated for the season, location, or activity involved.
- c. In order for any request of time extension due to unusually severe weather to be valid, the Contractor must document both of the following conditions.
 - 1. The weather experienced at the project site during the Contract period is more severe than the adverse weather anticipated for the project location during any given month.
 - 2. The unusually severe weather actually caused a delay to the completion of the project. The delay must be beyond the control and without fault or negligence by the Contractor.
- d. The following schedule of monthly anticipated adverse weather delays will constitute the baseline for monthly weather time evaluations. The Contractor's Progress Schedule must reflect these anticipated adverse weather delays in all weather affected activities:
MONTHLY ANTICIPATED ADVERSE WEATHER DELAY WORK DAYS BASED ON FIVE (5) DAY WORK WEEK

<u>JAN</u>	<u>FEB</u>	<u>MAR</u>	<u>APR</u>	<u>MAY</u>	<u>JUN</u>	<u>JUL</u>	<u>AUG</u>	<u>SEP</u>	<u>OCT</u>	<u>NOV</u>	<u>DEC</u>
10	8	7	6	7	7	5	5	5	4	5	9

END OF SECTION 01010

SECTION 01019

SPECIAL PROVISIONS

1. **GENERAL**
Should conflict occur between these Special Provisions and the General Conditions, the requirements of the Special Provisions shall take precedence.
2. **TIME OF CONSTRUCTION - LIQUIDATED DAMAGES**
 - a. **Time of Construction** - The Contractor will commence the work within ten (10) days after the Architect shall have given the Contractor written notice to commence construction to the satisfaction of the Owner within the calendar days as Contractor so stated in his Bid Form. The time for completion herein set forth shall be extended for the period of any reasonable delay which is due exclusively to causes beyond the control and without the fault of the Contractor, including acts of God, fires, floods, and direction by the Architect. It is impractical to perform any operation of construction and acts of omissions of the Owner with respect to matters for which Owner is solely responsible; provided, however, that no such extension of time for completion shall be granted the Contractor, unless within ten (10) days after the happening of any event relied upon by the Contractor for such extension of time, the Contractor shall have made a request, therefore, in writing to the Architect. Extended time will be submitted with pay request for Owner's approval.
 - b. **Liquidated Damages** - The time of completion of the construction of the project is of the essence of this Contract. Should the Contractor neglect, refuse, or fail to complete the project within the time herein agreed upon, after giving effect to extensions of time, if any, herein provided; then in that event and in view of the difficulty of estimating with exactness damages caused by such delay, the Owner shall have the right to deduct from and retain out of such money, which may then be due or which may become due and payable to the Contractor, the sum of THREE HUNDRED DOLLARS (\$300.00) per day for each and every day that such construction is delayed in its completion beyond the specified time, as liquidated damages and not as a penalty. If the amount due and to become due from the Contractor to the Owner is insufficient to pay in full any such liquidated damages, the Contractor shall pay to the Owner the amount necessary to effect such payment in full; provided, however, that the Owner shall promptly notify the Contractor in writing of the manner in which the amount retained, deducted or claimed as liquidated damages was computed.
 - c. **Joint Responsibility** - The General Contractor and/or Subcontractors causing the delay in completion of the project shall be responsible for payment of liquidated damages. In no case shall the total liquidated damages for all contracts exceed the sum of daily liquidated damages multiplied by the number of days of delay in completion.
3. **ALTERNATES - Refer to Alternate Schedule, Section 01030**
 - a. Alternates specified are not a part of Base Bid, but are Alternates to same, their acceptance being at option of Owner.
4. **ENUMERATION OF DRAWINGS AND SPECIFICATIONS**
 - a. **Correlation.** Accompanying these Specifications are the Drawings, which jointly with these Specifications, are intended to explain each other and describe and coordinate the work to be performed under the Contract.
 - b. **Verification of Documents.** Before submitting his bid, each Bidder shall check his set(s) of Drawings and Specifications and advise the Architect if any sheets are missing.
 - c. **Specifications Explanations.** For convenience of reference, the Specifications are separated into Titled Divisions and Sections. Such separation shall not, however, operate to make the Architect an arbiter to establish limits between the Contractor and Subcontractor or Sub-Subcontractor.
 - d. **Drawings.** Refer to LIST OF DRAWINGS.
 - e. **Specifications.** Refer to TABLE OF CONTENTS.

5. WARRANTIES

Before being eligible for final payment, Contractor shall deliver to Owner, through Architect, all special warranties specified for materials, equipment and installation.

6. OPERATING INSTRUCTIONS

Before being eligible for final payment, Contractor shall deliver to Owner, through Architect, three (3) copies of manufacturer's operating instructions, one (1) complete set of shop drawings on each piece of equipment, and such framed instructions as instructed.

7. AS-BUILT DRAWINGS

Before being eligible for final payment, the Electrical and Mechanical Contractors shall prepare and deliver to Owner, through Architect, one (1) set of AS-BUILT DRAWINGS. These drawings may consist of marked-up prints, if the Contractor so chooses, but shall show the correct location of every item of equipment, piping, conduit, panel boards, ductwork, switches, valves, etc. If marked-up prints are used, they shall be new white prints.

8. CERTIFICATE OF COMPLIANCE

Upon completion of project, Contractor is to furnish written Certification to the Architect that he has complied with every paragraph of the Specifications and Drawings.

9. CONTRACTOR'S MONTHLY APPLICATION FOR PAYMENT FORM

Contractor's monthly Application for Payment shall be submitted as per General Conditions. AIA Document G702, Application and Certificate for Payment is approved and acceptable.

10. FILING AND RECORDING OF BONDS

In addition to furnishing the number of combination Performance Bond and Labor and Materials Payment Bond, and Statutory Bond, if required, the Contractor shall file copies of such bonds with Clerk of the District Court and furnish Architect with receipt furnished by Clerk of the District Court, covering charges for filing and recording of said bonds.

11. STATUTORY BONDS

In addition to furnishing the combination Performance and Labor and Materials Payment Bond specified in General Conditions, the Contractor shall furnish Statutory Bond in an amount not less than 100% of the Agreement in such numbers and form stated in Sample Copy bound in the Specifications. Statutory Bond shall be filed and recorded with Clerk of the District Court, as specified in Paragraph - FILING AND RECORDING OF BONDS.

12. DOCUMENTS FURNISHED CONTRACTORS

The General Contractor will be furnished, free of charge, the following working drawings and specifications, including modifications for construction of the project - 20 sets. The General Contractor will be responsible for distribution of these sets to the Subcontractors and suppliers. The Contractor shall pay the actual cost of reproduction and postage for all additional sets requested by him.

13. SALES TAX EXEMPTIONS

- a. Materials, labor and equipment incorporated into this project are not exempt from the payment of sales tax under the laws of the **State of Wyoming** and such sales tax **shall be included in the Bid of the Bidder.**

END OF SECTION 01019

SECTION 01030

ALTERNATES

PART 1 – GENERAL

1.1 RELATED DOCUMENTS

- A. Drawings and general provisions of the Contract, including General and Supplementary Conditions and other Division 1 Specification Sections, apply to this Section.

1.2 SUMMARY

- A. This Section includes administrative and procedural requirements for alternates.

1.3 DEFINITIONS

- A. Alternate: An amount proposed by bidders and stated on the Bid Form for certain work defined in the Bidding Requirements that may be added to or deducted from the Base Bid amount if Owner decides to accept a corresponding change either in the amount of construction to be completed or in the products, materials, equipment, systems, or installation methods described in the Contract Documents.
 - 1. The cost or credit for each alternate is the net addition to or deduction from the Contract Sum to incorporate alternate into the Work. No other adjustments are made to the Contract Sum.

1.4 PROCEDURES

- A. Coordination: Modify or adjust affected adjacent work as necessary to completely integrate work of the alternate into Project.
 - 1. Include as part of each alternate, miscellaneous devices, accessory objects, and similar items incidental to or required for a complete installation whether or not indicated as part of alternate.
- B. Notification: Immediately following award of the Contract, notify each party involved, in writing, of the status of each alternate. Indicate if alternates have been accepted, rejected, or deferred for later consideration. Include a complete description of negotiated modifications to alternates.
- C. Execute accepted alternates under the same conditions as other work of the Contract.
- D. Schedule: A Schedule of Alternates is included at the end of this Section. Specification Sections referenced in schedule contain requirements for materials necessary to achieve the work described under each alternate.

PART 2 - EXECUTION

2.1 SCHEDULE OF ALTERNATES

- A. Schedule of Alternates
 - 1. General; The General Contractor shall state in his Bid Form the amount of dollars to be ADDED or DEDUCTED from his Base Bid for the following Alternates. Alternates are not in order of acceptance.

Alternate #1; In lieu of Hardi-Plank Siding at the interior Breezeway walls only, install Hardi-Panel siding and joint trim. Batten trim and joints to be coordinated, equally spaced and consistent panel sizes, all panels to be larger than 24” wide, and work with layout.

Alternate #2; Per Addendum

END OF SECTION 01030

SECTION 01500

TEMPORARY FACILITIES

1. GENERAL

Should conflict occur between the Temporary Facilities and the General Conditions, the requirements of this Section take precedence.

2. TEMPORARY HEAT

- a. The General Contractor shall provide heat, fuel and services as necessary to protect all work and materials against injury from dampness and cold until final acceptance of all work and material in the Contract, unless the building or buildings are fully occupied by the Owner prior to such acceptance, in which case, the Owner shall assume all expenses of heating from date of occupancy. The General Contractor shall provide heat as follows:
- 1) At all times during the placing, setting and curing of concrete, provide sufficient heat to insure the heating of the spaces involved to not less than 50° F.
 - 2) From the beginning of the application of gypsum board taping and during the setting and curing period, provide sufficient heat to produce a temperature in the spaces involved of not less than 50° F.
 - 3) For a period of ten (10) days previous to the placing of interior wood finish and throughout the placing of this and other interior finishing, varnishing, painting, etc., and until final acceptance of the work or until full occupancy by the Owner, provide sufficient heat to produce a temperature of not less than 70° F. Heating Subcontractor shall set such necessary temporary radiation as may be required.
 - 4) Mechanical Subcontractor shall, as soon as possible, provide temporary heating facilities through the installed heating equipment.

3. SIGN AND ADVERTISING

- a. The General Contractor shall furnish and erect one (1) painted sign, 4'-0" x 8'-0" in size, as shown on the last page of this Section and placed where directed. Sign shall have the following:
- 1) Name of Project
 - 2) Name and Address of Architect
 - 3) Name and Address of General Contractor
 - 4) Name of Mechanical Subcontractor
 - 5) Name of Electrical Subcontractor
 - 6) Picture of Project, if available (coordinate with Architect)
- b. Post entire construction with DANGER and NO TRESPASSING signs to comply with safety and insurance regulations.
- c. Keep premises clear and free from other signs or posters.

4. TEMPORARY FIELD OFFICES

- a. General Contractor shall provide and maintain in good condition, a painted weatherproof field office (adequate size trailer acceptable) for use of General Contractor and Architect's representative. Provide such building with heat, electric lights, telephone, locked doors, windows, table, and rack for Drawings. Building to remain property of General Contractor.
- b. Electrical and Mechanical Subcontractors shall maintain similar field office, meeting requirements of previous paragraph, except provisions for Architect's representative not needed.

5. TEMPORARY ENCLOSURES

General Contractor to provide:

- a. Temporary weathertight enclosures for all exterior openings as soon as possible as walls and roofs are built to protect work from weather. Temporary exterior doors equipped with padlocks.
- b. In cold weather, provide additional precautions necessary, including heat at such openings to protect building and contents.

6. TEMPORARY SHEDS

The Contractor shall provide and maintain on the premises watertight storage sheds for storage of all materials which may be damaged by weather. These sheds shall have wood floors raised above the ground.

7. TEMPORARY CONSTRUCTION ITEMS

General Contractor shall furnish necessary temporary stairs, chutes, runways, scaffolds, ladders and hoist.

8. TEMPORARY TOILET ACCOMMODATIONS

- a. The General Contractor shall provide for the use of all workmen, in accordance with local ordinances, ample temporary sanitary toilet accommodations and keep such clean and free from flies. Prior to completion of the Contract, all connections and appliances connected with same will be removed and the premises left perfectly clean.
- b. The Mechanical Subcontractor shall, as soon as conditions of the work will allow, install inside building a temporary toilet with connections to the sewer.

9. TEMPORARY TELEPHONE

The General Contractor shall install at his own expense, a job telephone, and shall pay for all local calls. All long distance calls shall be paid by party making the call.

10. TEMPORARY LIGHT AND POWER

- a. For new construction, the General Contractor shall arrange for temporary service, pay for all expenses therewith and bring services to building and run extensions to locations necessary for operations.
- b. Permit other Subcontractors to use same. Other Subcontractors requiring additional extensions, make and remove same at their expense. General Contractor shall pay for all electricity consumed.

11. WATER FOR CONSTRUCTION

The Owner will furnish all water for construction. The General Contractor will be responsible for necessary water connections to existing source, if available.

END OF SECTION 01500

SECTION 019113
GENERAL COMMISSIONING REQUIREMENTS

PART 1 GENERAL

1.1 SUMMARY

- A. Commissioning is intended to achieve the following specific objectives; this section specifies the Contractor's responsibilities for commissioning:
 - 1. Verify that the work is installed in accordance with Contract Documents and the manufacturer's recommendations and instructions, and that it receives adequate operational checkout prior to startup: Startup reports and Prefunctional Checklists executed by Contractor are utilized to achieve this.
 - 2. Verify and document that functional performance is in accordance with Contract Documents: Functional Tests executed by Contractor and witnessed by the Commissioning Authority are utilized to achieve this.
 - 3. Verify that operation and maintenance manuals submitted to Owner are complete: Detailed operation and maintenance (O&M) data submittals by Contractor are utilized to achieve this.
 - 4. Verify that the Owner's operating personnel are adequately trained: Formal training conducted by Contractor is utilized to achieve this.
- B. Commissioning, including Functional Tests, O&M documentation review, and training, is to occur after startup and initial checkout and be completed before Substantial Completion.
- C. The Commissioning Authority directs and coordinates all commissioning activities; this section describes some but not all of the Commissioning Authority's responsibilities.
- D. The Commissioning Authority is employed by Construction Manager on behalf of Owner.

1.2 SCOPE OF COMMISSIONING

- A. The following are to be commissioned:
- B. Building envelope:
 - 1. Air tightness.
- C. Plumbing Systems:
 - 1. Water heaters.
 - 2. Booster pumps.
 - 3. Circulating pumps.
- D. HVAC System, including:
 - 1. Major and minor equipment items.
 - 2. Ductwork and accessories.
 - 3. Control system.
- E. Electrical Systems:
 - 1. Lighting controls other than manual switches.
- F. Other equipment and systems explicitly identified elsewhere in Contract Documents as requiring commissioning.

1.3 RELATED REQUIREMENTS

- A. Section 019114 - Commissioning Authority Responsibilities.

1.4 REFERENCE STANDARDS

- A. ANSI/RESNET/ICC 301 - Standard for the Calculation and Labeling of the Energy Performance of Low-Rise Residential Buildings using an Energy Rating Index; 2014.
- B. ANSI/RESNET/ICC 380 - Standard for Testing Airtightness of Building Enclosures, Airtightness of Heating and Cooling Air Distribution Systems, and Airflow of Mechanical Ventilation Systems; 2016.
- C. ASTM E779 - Standard Test Method for Determining Air Leakage Rate by Fan Pressurization; 2019.

- D. ASTM E1827 - Standard Test Methods for Determining Airtightness of Buildings Using an Orifice Blower Door; 2011 (Reapproved 2017).

1.5 SUBMITTALS

- A. See Section 013000 - Administrative Requirements, for submittal procedures; except:
 - 1. Make all submittals specified in this section, and elsewhere where indicated for commissioning purposes, directly to the Commissioning Authority, unless they require review by Architect; in that case, submit to Architect first.
 - 2. Submit one copy to the Commissioning Authority, not to be returned.
 - 3. Make commissioning submittals on time schedule specified by Commissioning Authority.
 - 4. Submittals indicated as "Draft" are intended for the use of the Commissioning Authority in preparation of Prefunctional Checklists or Functional Test requirements; submit in editable electronic format, Microsoft Word 2010 preferred.
 - 5. As soon as possible after submittals made to Architect are approved, submit copy of approved submittal to the Commissioning Authority.
- B. Product Data: If submittals to Architect do not include the following, submit copies as soon as possible:
 - 1. Manufacturer's product data, cut sheets, and shop drawings.
 - 2. Manufacturer's installation instructions.
 - 3. Startup, operating, and troubleshooting procedures.
 - 4. Fan and pump curves.
 - 5. Factory test reports.
 - 6. Warranty information, including details of Owner's responsibilities in regard to keeping warranties in force.
- C. Manufacturers' Instructions: Submit copies of all manufacturer-provided instructions that are shipped with the equipment as soon as the equipment is delivered.
- D. Startup Plans and Reports.
- E. Completed Prefunctional Checklists.
- F. Commissioning Issues Log:
 - 1. Construction observations.
 - 2. Supporting photographs.
- G. HERS Rating Report: Include the following mandatory completed reports for ENERGY STAR Certified Homes:
 - 1. HVAC Commissioning Checklist.

1.6 QUALITY ASSURANCE

- A. HERS (Home Energy Rating System) Rater: Residential Energy Services Network (RESNET) certified professional.

PART 2 PRODUCTS

2.1 TEST EQUIPMENT

- A. Provide all standard testing equipment required to perform startup and initial checkout and required Functional Testing; unless otherwise noted such testing equipment will NOT become the property of Owner.
- B. Provide all standard testing equipment required to perform building envelope air tightness testing; unless otherwise noted such testing equipment will NOT become the property of Owner.
- C. Calibration Tolerances: Provide testing equipment of sufficient quality and accuracy to test and/or measure system performance with the tolerances specified. If not otherwise noted, the following minimum requirements apply:
 - 1. Temperature Sensors and Digital Thermometers: Certified calibration within past year to accuracy of 0.5 degree F and resolution of plus/minus 0.1 degree F.
 - 2. Pressure Sensors: Accuracy of plus/minus 2.0 percent of the value range being measured (not full range of meter), calibrated within the last year.

3. Calibration: According to the manufacturer's recommended intervals and when dropped or damaged; affix calibration tags or keep certificates readily available for inspection.
- D. Equipment-Specific Tools: Where special testing equipment, tools and instruments are specific to a piece of equipment, are only available from the vendor, and are required in order to accomplish startup or Functional Testing, provide such equipment, tools, and instruments as part of the work at no extra cost to Owner; such equipment, tools, and instruments are to become the property of Owner.
- E. Dataloggers: Independent equipment and software for monitoring flows, currents, status, pressures, etc. of equipment.
 1. Dataloggers required to for Functional Tests will be provided by the Commissioning Authority and will not become the property of Owner.

PART 3 EXECUTION

3.1 COMMISSIONING PLAN

- A. Commissioning Authority will prepare the Commissioning Plan.
 1. Attend meetings called by the Commissioning Authority for purposes of completing the commissioning plan.
 2. Require attendance and participation of relevant subcontractors, installers, suppliers, and manufacturer representatives.
- B. Contractor is responsible for compliance with the Commissioning Plan.
- C. Commissioning Plan: The commissioning schedule, procedures, and coordination requirements for all parties in the commissioning process.
- D. Commissioning Schedule:
 1. Submit anticipated dates of startup of each item of equipment and system to Commissioning Authority within 60 days after award of Contract.
 2. Re-submit anticipated startup dates monthly, but not less than 4 weeks prior to startup.
 3. Prefunctional Checklists and Functional Tests are to be performed in sequence from components, to subsystems, to systems.
 4. Provide sufficient notice to Commissioning Authority for delivery of relevant Checklists and Functional Test procedures, to avoid delay.

3.2 STARTUP PLANS AND REPORTS

- A. Startup Plans: For each item of equipment and system for which the manufacturer provides a startup plan, submit the plan not less than 8 weeks prior to startup.
- B. Startup Reports: For each item of equipment and system for which the manufacturer provides a startup checklist (or startup plan or field checkout sheet), document compliance by submitting the completed startup checklist prior to startup, signed and dated by responsible entity.
- C. Submit directly to the Commissioning Authority.

3.3 PREFUNCTIONAL CHECKLISTS

- A. A Prefunctional Checklist is required to be filled out for each item of equipment or other assembly specified to be commissioned.
 1. No sampling of identical or near-identical items is allowed.
 2. These checklists do not replace manufacturers' recommended startup checklists, regardless of apparent redundancy.
 3. Prefunctional Checklist forms will not be complete until after award of the contract; the following types of information will be gathered via the completed Checklist forms:
 - a. Certification by installing contractor that the unit is properly installed, started up, and operating and ready for Functional Testing.
 - b. Confirmation of receipt of each shop drawing and commissioning submittal specified, itemized by unit.
 - c. Manufacturer, model number, and relevant capacity information; list information "as specified," "as submitted," and "as installed."

- d. Serial number of installed unit.
 - e. List of inspections to be conducted to document proper installation prior to startup and Functional Testing; these will be primarily static inspections and procedures; for equipment and systems may include normal manufacturer's start-up checklist items and minor testing.
 - f. Sensor and actuator calibration information.
- B. Contractor is responsible for filling out Prefunctional Checklists, after completion of installation and before startup; witnessing by the Commissioning Authority is not required unless otherwise specified.
- 1. Each line item without deficiency is to be witnessed, initialed, and dated by the actual witness; checklists are not complete until all line items are initialed and dated complete without deficiencies.
 - 2. Checklists with incomplete items may be submitted for approval provided the Contractor attests that incomplete items do not preclude the performance of safe and reliable Functional Testing; re-submission of the Checklist is required upon completion of remaining items.
 - 3. Individual Checklists may contain line items that are the responsibility of more than one installer; Contractor shall assign responsibility to appropriate installers or subcontractors, with identification recorded on the form.
 - 4. If any Checklist line item is not relevant, record reasons on the form.
 - 5. Contractor may independently perform startup inspections and/or tests, at Contractor's option.
 - 6. Regardless of these reporting requirements, Contractor is responsible for correct startup and operation.
 - 7. Submit completed Checklists to Commissioning Authority within two days of completion.
- C. Commissioning Authority is responsible for furnishing the Prefunctional Checklists to Contractor.
- 1. Initial Drafts: Contractor is responsible for initial draft of Prefunctional Checklist where so indicated in Contract Documents.
 - 2. Provide all additional information requested by Commissioning Authority to aid in preparation of checklists, such as shop drawing submittals, manufacturers' startup checklists, and O&M data.
 - 3. Commissioning Authority may add any relevant items deemed necessary regardless of whether they are explicitly mentioned in Contract Documents or not.
 - 4. When asked to review the proposed Checklists, do so in a timely manner.
- D. Deficiencies: Correct deficiencies and re-inspect or re-test, as applicable, at no extra cost to Owner.
- 1. If difficulty in correction would delay progress, report deficiency to the Commissioning Authority immediately.

3.4 FUNCTIONAL TESTS

- A. A Functional Test is required for each item of equipment, system, or other assembly specified to be commissioned, unless sampling of multiple identical or near-identical units is allowed by the final test procedures.
- B. Contractor is responsible for execution of required Functional Tests, after completion of Prefunctional Checklist and before closeout.
- C. Commissioning Authority is responsible for witnessing and reporting results of Functional Tests, including preparation and completion of forms for that purpose.
- D. Contractor is responsible for correction of deficiencies and re-testing at no extra cost to Owner; if a deficiency is not corrected and re-tested immediately, the Commissioning Authority will document the deficiency and the Contractor's stated intentions regarding correction.
- 1. Deficiencies are any condition in the installation or function of a component, piece of equipment or system that is not in compliance with Contract Documents or does not perform properly.
 - 2. When the deficiency has been corrected, the Contractor completes the form certifying that the item is ready to be re-tested and returns the form to the Commissioning Authority; the Commissioning Authority will reschedule the test and the Contractor shall re-test.
 - 3. Identical or Near-Identical Items: If 10 percent, or three, whichever is greater, of identical or near-identical items fail to perform due to material or manufacturing defect, all items will be considered defective; provide a proposal for correction within 2 weeks after notification of defect, including provision for testing sample installations prior to replacement of all items.

4. Contractor shall bear the cost of Owner and Commissioning Authority personnel time witnessing re-testing.
 5. Contractor shall bear the cost of Owner and Commissioning Authority personnel time witnessing re-testing if the test failed due to failure to execute the relevant Prefunctional Checklist correctly; if the test failed for reasons that would not have been identified in the Prefunctional Checklist process, Contractor shall bear the cost of the second and subsequent re-tests.
- E. Functional Test Procedures:
1. Some test procedures are included in Contract Documents; where Functional Test procedures are not included in Contract Documents, test procedures will be determined by the Commissioning Authority with input by and coordination with Contractor.
 2. Examples of Functional Testing:
 - a. Test the dynamic function and operation of equipment and systems (rather than just components) using manual (direct observation) or monitoring methods under full operation (e.g., the chiller pump is tested interactively with the chiller functions to see if the pump ramps up and down to maintain the differential pressure setpoint).
 - b. Systems are tested under various modes, such as during low cooling or heating loads, high loads, component failures, unoccupied, varying outside air temperatures, fire alarm, power failure, etc.
 - c. Systems are run through all the HVAC control system's sequences of operation and components are verified to be responding as the sequence's state.
 - d. Traditional air or water test and balancing (TAB) is not Functional Testing; spot checking of TAB by demonstration to the Commissioning Authority is Functional Testing.
- F. Deferred Functional Tests: Some tests may need to be performed later, after substantial completion, due to partial occupancy, equipment, seasonal requirements, design or other site conditions; performance of these tests remains the Contractor's responsibility regardless of timing.
- 3.5 TEST PROCEDURES - GENERAL
- A. Provide skilled technicians to execute starting of equipment and to execute the Functional Tests. Ensure that they are available and present during the agreed upon schedules and for sufficient duration to complete the necessary tests, adjustments and problem-solving.
 - B. Provide all necessary materials and system modifications required to produce the flows, pressures, temperatures, and conditions necessary to execute the test according to the specified conditions. At completion of the test, return all affected equipment and systems to their pre-test condition.
 - C. Sampling: Where Functional Testing of fewer than the total number of multiple identical or near-identical items is explicitly permitted, perform sampling as follows:
 1. Identical Units: Defined as units with same application and sequence of operation; only minor size or capacity difference.
 2. Sampling is not allowed for:
 - a. Major equipment.
 - b. Life-safety-critical equipment.
 - c. Prefunctional Checklist execution.
 3. XX = the percent of the group of identical equipment to be included in each sample; defined for specific type of equipment.
 4. YY = the percent of the sample that if failed will require another sample to be tested; defined for specific type of equipment.
 5. Randomly test at least XX percent of each group of identical equipment, but not less than three units. This constitutes the "first sample."
 6. If YY percent of the units in the first sample fail, test another XX percent of the remaining identical units.
 7. If YY percent of the units in the second sample fail, test all remaining identical units.
 8. If frequent failures occur, resulting in more troubleshooting than testing, the Commissioning Authority may stop the testing and require Contractor to perform and document a checkout of the remaining units prior to continuing testing.

- D. Manual Testing: Use hand-held instruments, immediate control system readouts, or direct observation to verify performance (contrasted to analyzing monitored data taken over time to make the “observation”).
- E. Simulating Conditions: Artificially create the necessary condition for the purpose of testing the response of a system; for example apply hot air to a space sensor using a hair dryer to see the response in a VAV box.
- F. Simulating Signals: Disconnect the sensor and use a signal generator to send an amperage, resistance or pressure to the transducer and control system to simulate the sensor value.
- G. Over-Writing Values: Change the sensor value known to the control system in the control system to see the response of the system; for example, change the outside air temperature value from 50 degrees F to 75 degrees F to verify economizer operation.
- H. Indirect Indicators: Remote indicators of a response or condition, such as a reading from a control system screen reporting a damper to be 100 percent closed, are considered indirect indicators.
- I. Monitoring: Record parameters (flow, current, status, pressure, etc.) of equipment operation using dataloggers or the trending capabilities of the relevant control systems; where monitoring of specific points is called for in Functional Test Procedures:
 - 1. All points that are monitored by the relevant control system shall be trended by Contractor; at the Commissioning Authority’s request, Contractor shall trend up to 20 percent more points than specified at no extra charge.
 - 2. Other points will be monitored by the Commissioning Authority using dataloggers.
 - 3. At the option of the Commissioning Authority, some control system monitoring may be replaced with datalogger monitoring.
 - 4. Provide hard copies of monitored data in columnar format with time down left column and at least 5 columns of point values on same page.
 - 5. Graphical output is desirable and is required for all output if the system can produce it.
 - 6. Monitoring may be used to augment manual testing.

3.6 BUILDING ENVELOPE COMMISSIONING

- A. General: Comply with the following procedural requirements:
 - 1. ASTM E779 Standard Test Method for Determining Air Leakage Rate by Fan Pressurization.
 - 2. ASTM E1827 Standard Test Methods for Determining Airtightness of Buildings Using an Orifice Blower Door.
 - 3. ANSI/RESNET/ICC 301 Standard for the Calculation and Labeling of the Energy Performance of Low-Rise Residential Buildings using an Energy Rating Index.
 - 4. ANSI/RESNET/ICC 380 Standard for Testing Airtightness of Building Enclosures, Airtightness of Heating and Cooling Air Distribution Systems, and Airflow of Mechanical Ventilation Systems.
- B. Verify that the building envelope has been sufficiently completed for testing to commence.
- C. Conduct ongoing inspections as construction progresses to document satisfactory installation conditions related to thermal and moisture integrity of the building envelope that become concealed upon completion of construction.
- D. Submit a detailed narrative of proposed pressure test procedures prior to the test. Include a plan view showing proposed installation locations (personnel doors or other similar openings) for blower doors (or flexible ducts for trailer-mounted fans, if used).
- E. Test the completed building and demonstrate that the air leakage rate of the building envelope does not exceed the specified requirements.

3.7 OPERATION AND MAINTENANCE MANUALS

- A. Add design intent documentation furnished by Architect to manuals prior to submission to Owner.
- B. Submit manuals related to items that were commissioned to Commissioning Authority for review; make changes recommended by Commissioning Authority.
- C. Commissioning Authority will add commissioning records to manuals after submission to Owner.

END OF SECTION 019113

SECTION 02110

SITE CLEARING

PART 1 GENERAL

1.01 SECTION INCLUDES

- A. Remove surface debris.
- C. Clear site of plant life and grass.
- D. Remove trees and shrubs.
- E. Remove root system of trees and shrubs.
- F. Topsoil excavation.

1.02 REGULATORY REQUIREMENTS

- A. Conform to applicable local codes and ordinances for disposal of debris, burning debris on site, use of herbicides, etc.
- B. Coordinate clearing Work with utility companies as required.

PART 2 PRODUCTS

Not Used

PART 3 EXECUTION

3.01 PREPARATION

- A. Verify that existing plant life designated to remain, is tagged, or identified.

3.02 PROTECTION

- A. Locate, identify, and protect utilities that remain, from damage.
- B. Protect trees, plant growth, and features designated to remain, as final landscaping.
- C. Protect bench marks and existing structures from damage or displacement.

3.03 CLEARING

- A. Clear areas required for access to site and execution of Work.
- B. Remove paving, curbs, and improvements designated.
- C. Remove trees and shrubs indicated. Remove stumps, root system surface rock, and other areas indicated or implied for completion of the project.
- D. Clear undergrowth and deadwood, without disturbing subsoil. Strip and clear vegetation from areas designated to be filled, excavated, regraded, or landscaped.

3.04 REMOVAL

- A. Remove debris, rock, and extracted plant life from site.

3.05 TOPSOIL EXCAVATION

- A. Excavate clean topsoil from areas to be further excavated, filled, re-landscaped, or regraded.
- B. Stockpile in area designated on site to depth not exceeding 8 feet. Protect from erosion. Remove excess topsoil not being reused, from site.

END OF SECTION 02110

SECTION 02205

SOIL MATERIALS

PART 1 GENERAL

1.01 SECTION INCLUDES

- A. Subsoil and topsoil materials.

1.02 RELATED SECTIONS

- A. Document:
The Geotechnical Engineering Report, by **Terracon, for the Reserves at Grand View Heights, Laramie, Wyoming, dated June 10, 2024**. The engineering study, subsurface exploration, boring location diagram, boring logs, laboratory test results, and geotechnical recommendations.
 - Any additional borings and reports completed by Terracon may be included in Addendums.

1.03 REFERENCES

- A. ANSI/ASTM D698 - Test Methods for Moisture-Density Relations of Soils and Soil-Aggregate Mixtures, Using 5.5 lb (2.49 Kg) Rammer and 12 inch (304.8 mm) Drop.
- B. ASTM D2487 - Classification of Soils for Engineering Purposes.

PART 2 PRODUCTS

2.01 SOIL MATERIALS

- A. Fill Material: Under slabs and within the zone of influence of foundation elements must be a material approved by the geotechnical engineer and as indicated in the geotechnical report.
- B. Fill and Backfill Material: Other areas, foundation backfill, site grading, and pavement, should be clean site material or similar borrow material.

2.02 SOURCE QUALITY CONTROL

- A. Inspection and testing will be performed by an independent laboratory, Contractor shall bear all related costs under provisions of General Requirements.
- B. Tests and analysis of soil material will be performed in accordance with ANSI/ASTM D698.
- C. If tests indicate materials do not meet specified requirements, change material and retest at no cost to Owner.

PART 3 EXECUTION

3.01 STOCKPILING

- A. Stockpile materials on site at locations indicated or in areas that will not impact project completion.
- B. Stockpile in sufficient quantities to meet project schedule and requirements.
- C. Separate differing materials with dividers or stockpile apart to prevent mixing.
- D. Direct surface water away from stockpile site to prevent erosion or deterioration of materials.

3.02 STOCKPILE CLEANUP

- A. Remove stockpile, leave area in a clean and neat condition. Grade site surface to prevent free-standing surface water.

END OF SECTION 02205

SECTION 02211

ROUGH GRADING

PART 1 GENERAL

1.01 SECTION INCLUDES

- A. Removal of topsoil and subsoil.
- B. Cutting, grading, filling, and rough contouring the site for site structures, building pads and paving.

1.02 RELATED SECTIONS

- A. Document:
The Geotechnical Engineering Report, by **Terracon, for the Reserves at Grand View Heights, Laramie, Wyoming, dated June 10, 2024**. The engineering study, subsurface exploration, boring location diagram, boring logs, laboratory test results, and geotechnical recommendations.
 - Any additional borings and reports completed by Terracon may be included in Addendums.

PART 2 PRODUCTS

2.01 MATERIALS

- A. Topsoil, Fill, and Structural Fill: As specified in Section 02205.

PART 3 EXECUTION

3.01 EXAMINATION

- A. Verify that survey bench mark and intended elevations for the Work are as indicated.

3.02 PREPARATION

- A. Identify required lines, levels, contours, and datum.
- B. Stake and flag locations of known utilities. Locate, identify, and protect utilities that remain, from damage. Notify utility company to remove and relocate utilities.
- C. Protect above and below grade utilities that remain.
- D. Protect plant life, lawns, rock outcropping and other features remaining as a portion of final landscaping.
- E. Protect bench marks, existing structures, fences, sidewalks, paving, and curbs from excavating equipment and vehicular traffic.

3.03 SUBSOIL EXCAVATION

- A. Excavate subsoil from areas to be further excavated, relandscaped, or regraded.
- B. Stockpile in area designated on site to depth not exceeding 8 feet. Protect from erosion. Remove subsoil not being reused, from site.
- C. When excavating through roots, perform work by hand and cut roots with sharp axe.

3.04 FILLING

- A. Fill areas to contours and elevations with unfrozen materials.
- B. Place fill materials on continuous layers and compact in accordance with Schedule at end of Section.
- C. Maintain optimum moisture content of fill materials to attain required compaction density.
- D. Slope grade away from building minimum 2 inches in 10 ft. unless noted otherwise.
- E. Make grade changes gradual. Blend slope into level areas.
- F. Remove surplus fill materials from site.

3.05 TOLERANCES

- A. Top Surface of Subgrade: Plus or minus 1/10 foot.

3.06 FIELD QUALITY CONTROL

- A. Field inspection and testing will be performed under provisions of the General Requirements.
- B. Compaction testing will be performed in accordance with ANSI/ASTM D698.

- C. If tests indicate Work does not meet specified requirements, remove Work, replace, and retest at no additional cost to the Owner.

3.07 SCHEDULES

- A. Structural Fill: (Building and Paving)
 - 1. Fill Maximum 8 inches compacted depth.
 - 2. Compact to minimum 95 percent of maximum density.
- B. Subsoil Fill:
 - 1. Fill Maximum 8 inches compacted depth.
 - 2. Compact to minimum 90 percent of maximum density.
- C. Topsoil Fill:
 - 1. Fill Maximum 8 inches depth.

END OF SECTION 02211

SECTION 02222

EXCAVATING

PART 1 GENERAL

1.01 SECTION INCLUDES

- A. Excavating for building foundations and footings.
- B. Excavating for slabs-on-grade, paving, landscaping.
- C. Excavating for site structures.

1.02 RELATED SECTIONS

- A. Document:
The Geotechnical Engineering Report, by **Terracon, for the Reserves at Grand View Heights, Laramie, Wyoming, dated June 10, 2024.** The engineering study, subsurface exploration, boring location diagram, boring logs, laboratory test results, and geotechnical recommendations.
 - Any additional borings and reports completed by Terracon may be included in Addendums

PART 2 PRODUCTS

Not Used

PART 3 EXECUTION

3.01 PREPARATION

- A. Identify required lines, levels, contours, and datum.
- B. Locate, identify, and protect utilities that remain, from damage.
- C. Notify utility company to remove and relocate utilities.
- D. Protect plant life, lawns, rock outcropping and other features remaining as a portion of final landscaping.
- E. Protect bench marks, existing structures, fences, sidewalks, paving and curbs from excavation equipment and vehicular traffic.

3.02 EXCAVATION

- A. Underpin adjacent structures which may be damaged by excavation work.
- B. Excavate subsoil required to accommodate building foundations, slabs-on-grade, paving and site structures, construction operations.
- C. Machine slope banks to angle of repose or less, until shored.
- D. Do not interfere with 45 degree bearing splay of foundation.
- E. Grade top perimeter of excavation to prevent surface water from draining into excavation.
- F. Hand trim excavation. Remove loose matter.
- G. Remove lumped subsoil, boulders, and rock up to 1/3 cu yd measured by volume.
- H. Notify Architect/Engineer of unexpected subsurface conditions and discontinue affected Work in area until notified to resume work.
- I. Correct areas over-excavated in accordance with Section 02223.
- J. Stockpile excavated material in area designated on site and remove excess material not being reused, from site.

3.03 FIELD QUALITY CONTROL

- A. Field inspection will be performed under provisions of the General Requirements.
- B. Provide for visual inspection of bearing surfaces.

3.04 PROTECTION

- A. Protect excavations by methods required to prevent cave-in or loose soil from falling into excavation.
- B. Protect bottom of excavations and soil adjacent to and beneath foundation, from freezing.

END OF SECTION 02222

SECTION 02223

BACKFILLING

PART 1 GENERAL

1.01 SECTION INCLUDES

- A. Building perimeter and site structure backfilling to subgrade elevations.
- B. Site filling and backfilling.
- C. Fill under slabs-on-grade, paving.
- D. Consolidation and compaction as scheduled.
- E. Fill for over-excavation.

1.02 RELATED SECTIONS

- A. Document:
The Geotechnical Engineering Report, by **Terracon, for the Reserves at Grand View Heights, Laramie, Wyoming, dated June 10, 2024**. The engineering study, subsurface exploration, boring location diagram, boring logs, laboratory test results, and geotechnical recommendations.
 - Any additional borings and reports completed by Terracon may be included in Addendums.

1.03 REFERENCES

- A. ANSI/ASTM D698 - Test Methods for Moisture-Density Relations of Soils and Soil-Aggregate Mixtures, Using 5.5 lb (2.49 Kg) Rammer and 12 inch (304.8 mm) Drop.

PART 2 PRODUCTS

2.01 FILL MATERIALS

- A. Fill: As specified in Section 02205.

PART 3 EXECUTION

3.01 EXAMINATION

- A. Verify subdrainage, dampproofing or waterproofing installation has been inspected and completed.

3.02 PREPARATION

- A. Compact subgrade to density requirements for subsequent backfill materials.
- B. Cut out soft areas of subgrade not capable of in situ compaction. Backfill with fill and compact to density equal to or greater than requirements for subsequent fill material.
- C. Scarify and proof roll subgrade surface to a depth of 4 inches to identify soft spots; fill and compact to density equal to or greater than requirements for subsequent fill material.

3.03 BACKFILLING

- A. Backfill areas to contours and elevations with unfrozen materials.
- B. Systematically backfill to allow maximum time for natural settlement. Do not backfill over porous, wet, frozen or spongy subgrade surfaces.
- C. Fill, place and compact materials in continuous layers not exceeding 8 inches compacted depth.
- D. Employ a placement method that does not disturb or damage other work.
- E. Maintain optimum moisture content of backfill materials to attain required compaction density. Backfill against supported foundation walls. Do not backfill against unsupported foundation walls.
- F. Backfill simultaneously on each side of unsupported foundation walls until supports are in place.
- G. Slope grade away from building minimum 2 inches in 10 ft. unless noted otherwise.
- H. Make gradual grade changes. Blend slope into level areas.
- I. Remove surplus backfill materials from site.
- J. Leave fill material stockpile areas free of excess fill materials.

3.04 TOLERANCES

- A. Top Surface of Backfilling Under Paved Areas: Plus or minus 1 inch from required elevations.
- B. Top Surface of General Backfilling: Plus or minus 1 inch from required elevations.

- 3.05 FIELD QUALITY CONTROL
 - A. Field inspection and testing will be performed under provisions of the General Requirements.
 - B. Compaction testing will be performed in accordance with ANSI/ASTM D698.
 - C. If tests indicate Work does not meet specified requirements, remove Work, replace, and retest at no additional cost to the Owner.
 - D. Proof roll compacted fill surfaces under slabs-on-grade, and paving.

- 3.06 PROTECTION OF FINISHED WORK
 - A. Protect finished Work under provisions of the General Requirements.
 - B. Reshape and re-compact fills subjected to vehicular traffic.

- 3.07 SCHEDULE
 - A. Interior Slab-On-Grade:
 - 1. Fill compacted to 95 percent
 - 2. Cover with Sand Fill 2 inches thick, compacted to 95 percent.
 - B. Exterior Side of Foundation Walls Retaining Walls and Over Granular Filter Material and Foundation Perimeter Drainage:
 - 1. Fill to subgrade elevation, each lift, compacted to 90 percent.
 - C. Fill Under Grass Areas:
 - 1. Fill to 4 inches below finish grade.
 - D. Fill Under Asphalt or Concrete Paving:
 - 1. Compact subsoil to 95 percent of its maximum dry density.
 - E. Fill to Correct Overexcavation:
 - 1. Lean concrete to minimum compressive strength of 1000 psi.
 - 2. Compact approved fill to 95 percent of its maximum dry density.

END OF SECTION 02223

SECTION 02225

TRENCHING

PART 1 GENERAL

1.01 SECTION INCLUDES

- A. Excavating trenches for utilities from 5 feet outside building to municipal utilities.
- B. Compacted fill from top of utility bedding to subgrade elevations.
- C. Backfilling and compaction.

1.02 RELATED SECTIONS

- A. Document:
The Geotechnical Engineering Report, by **Terracon, for the Reserves at Grand View Heights, Laramie, Wyoming, dated June 10, 2024**. The engineering study, subsurface exploration, boring location diagram, boring logs, laboratory test results, and geotechnical recommendations.
 - Any additional borings and reports completed by Terracon may be included in Addendums.

1.03 REFERENCES

- A. ANSI/ASTM D698 - Test Methods for Moisture-Density Relations of Soils and Soil-Aggregate Mixtures, Using 5.5 lb (2.49 Kg) Rammer and 12 inch (304.8 mm) Drop.

1.04 FIELD MEASUREMENTS

- A. Verify that survey bench mark and intended elevations for the Work are as shown on drawings.

1.05 COORDINATION

- A. Coordinate all work as required.
- B. Verify work associated with lower elevation utilities are complete before placing higher elevation utilities.

PART 2 PRODUCTS

2.01 FILL MATERIALS

- A. Fill: As specified in Section 02205.

PART 3 EXECUTION

3.01 PREPARATION

- A. Identify required lines, levels, contours, and datum.
- B. Protect plant life, lawns, rock outcropping and other features remaining as a portion of final landscaping.
- C. Protect bench marks, existing structures, fences, sidewalks, paving, and curbs from excavation equipment and vehicular traffic.
- D. Maintain and protect above and below grade utilities which are to remain.
- E. Cut out soft areas of subgrade not capable of in situ compaction. Backfill with fill and compact to density equal to or greater than requirements for subsequent backfill material.

3.02 EXCAVATION

- A. Excavate subsoil required for utilities to municipal utilities.
- B. Cut trenches sufficiently wide to enable installation and allow inspection.
- C. Do not interfere with 45 degree bearing splay of foundations.
- D. Hand trim excavation. Remove loose matter.
- E. Remove lumped subsoil, boulders, and rock up to 1/3 cu yd measured by volume.
- F. Correct areas over excavated in accordance with Section 02222.
- G. Stockpile excavated material in area designated on site and remove excess material not being used, from site.

3.03 BACKFILLING

- A. Backfill trenches to contours and elevations with unfrozen materials.

- B. Systematically backfill to allow maximum time for natural settlement. Do not backfill over porous, wet, frozen, or spongy subgrade surfaces.
 - C. Granular Fill: Place and compact materials in continuous layers not exceeding 8 inches compacted depth.
 - D. Soil Fill: Place and compact material in continuous layers not exceeding 8 inches compacted depth.
 - E. Employ a placement method that does not disturb or damage foundation perimeter drainage, conduit, or pipes in trench.
 - F. Maintain optimum moisture content of fill materials to attain required compaction density.
 - G. Remove surplus fill materials from site.
 - H. Leave fill material stockpile areas completely free of excess fill materials.
- 3.04 TOLERANCES
- A. Top Surface of Backfilling: Plus or minus 1 inch from required elevations.
- 3.05 FIELD QUALITY CONTROL
- A. Field inspection and testing will be performed under provisions of the General Requirements.
 - B. Compaction testing will be performed in accordance with ANSI/ASTM D698.
 - C. If tests indicate Work does not meet specified requirements, remove Work, replace, compact, and retest at no additional cost to the owner.
- 3.06 PROTECTION OF FINISHED WORK
- A. Protect or reshape and recompact fills subjected to vehicular traffic during construction.

END OF SECTION 02225

SECTION 02281

TERMITE CONTROL

PART 1 GENERAL

1.01 SECTION INCLUDES

- A. Soil treatment for termite control below grade, to interior and exterior foundation perimeter.

1.02 QUALIFICATIONS

- A. Applicator: Company specializing in performing the work of this Section with minimum 5 years documented experience approved by manufacturer, licensed, and approved regulations.

1.03 REGULATORY REQUIREMENTS

- A. Conform to requirements for application, application licensing, authority to use toxicant chemicals, and in accordance with EPA.
- B. Provide certificate of compliance from authority having jurisdiction indicating approval of toxicants.

1.04 SEQUENCING

- A. Apply toxicant 12 hours prior to installation of vapor barrier under slabs-on-grade and finish grading work outside foundations.
- B. Notify Architect 24 hours prior to application.

1.05 WARRANTY

- A. Provide five year warranty under provisions of the General Requirements.
- B. Warranty: Include coverage for damage and repairs to building and building contents caused by termites. Repair damage. Re-treat where required.
- C. Inspect and report annually to Owner in writing. Owner reserves the right to renew warranty for an additional five years.

PART 2 PRODUCTS

2.01 MATERIALS

- A. Toxicant Chemical: EPA and Local authority approved; (DRAGNET, DURSBAN TC, or as approved equal) synthetically color dyed to permit visual identification of treated soil.
- B. Diluent: Recommended by toxicant manufacturer.
- C. Mix toxicant to manufacturer's instructions.

PART 3 EXECUTION

3.01 EXAMINATION

- A. Verify all the site conditions and become familiar with project scope.
- B. Verify that soil surfaces are unfrozen, sufficiently dry to absorb toxicant, and ready to receive treatment.
- C. Verify final grading is complete.

3.02 APPLICATION

- A. Spray apply or Inject toxicant in accordance with manufacturer's instructions.
- B. Apply toxicant at locations indicated in Schedule at end of Section.
- C. Apply extra treatment to structure penetration surfaces such as pipe or ducts, and soil penetrations such as grounding rods or posts.
- D. Re-treat disturbed treated soil with same toxicant as original treatment. Retreat around building perimeter after top soil has been placed, directly adjacent to foundation wall.
- E. If inspection or testing identifies the presence of termites, re-treat soil and re-test.

3.03 PROTECTION OF FINISHED WORK

- A. Protect finished Work, post signage to warn workers that soil poisoning has been applied.
- B. Do not permit soil grading over treated work.

3.04 SCHEDULES

A. Locations:

1. Under Slabs-on-Grade including porches and stoops.
2. Both Sides of Foundation Surfaces.
3. Soil Within 10 feet of Building Perimeter.

END OF SECTION 02281

SECTION 02520

PORTLAND CEMENT CONCRETE PAVING

PART 1 GENERAL

1.01 SECTION INCLUDES

- A. Concrete sidewalks and stair steps, integral curbs, gutters, driveways and parking areas.

1.02 PERFORMANCE REQUIREMENTS

- A. Paving: Designed for parking and light duty commercial vehicles.

1.03 QUALITY ASSURANCE

- A. Perform work in accordance with ACI 301, requirements of Sections 03100, 03200 and 03300.
- B. Obtain cementitious materials from same source throughout.

1.04 ENVIRONMENTAL REQUIREMENTS

- A. Do not place concrete when base surface temperature is less than 40 degrees F, or surface is wet or frozen.

PART 2 PRODUCTS

2.01 FORM MATERIALS

- A. Wood or Steel form material, profiled to suit conditions.
- B. Joint Filler: ANSI/ASTM D1751 type; 3/4 inch thick.

2.02 REINFORCEMENT

- A. Welded Steel Wire Fabric: Plain type, ANSI/ASTM A185; 6x6 - 6x6 in flat sheets or coiled rolls.
- B. Reinforcing Steel: ASTM A615; 40 ksi yield grade; deformed billet steel bars; unfinished.

2.03 CONCRETE MATERIALS

- A. Cement: ASTM C150 Air Entraining - Type IA Portland type, natural color.
- B. Fine and Coarse Mix Aggregates: ASTM C33.
- C. Water: Potable, not detrimental to concrete.
- D. Air Entrainment: ASTM C260.
- E. Chemical Admixture: ASTM C494, as approved by Architect.

2.04 CONCRETE MIX - BY PERFORMANCE CRITERIA

- A. Mix concrete in accordance with, ACI 304. Deliver concrete in accordance with ASTM C94.
- B. Provide concrete to the following criteria:
 - 1. Compressive Strength: Reference schedule below.
 - 2. Slump: 1 to 2 inches.
 - 3. Minimum Water/Cement Ratio: 6.5 gallon/5.5 sack.
 - 4. Air Entrained: 5 percent.
- C. Use accelerating admixtures in cold weather only when approved by Architect/Engineer. Use of admixtures will not relax cold weather placement requirements.
- D. Use calcium chloride only when approved by Architect/Engineer.
- E. Use set retarding admixtures during hot weather only when approved by Architect/Engineer.

2.05 SOURCE QUALITY CONTROL

- A. Submit proposed mix design of each class of concrete to the architect and appointed testing laboratory firm for review prior to commencement of work.
- B. Tests on cement and aggregates shall be performed to ensure conformance with specified requirements.

PART 3 EXECUTION

3.01 EXAMINATION

- A. Verify compacted subgrade, granular base and stabilized soil is acceptable and ready to support paving and imposed loads.
- B. Verify gradients and elevations of base are correct.

3.02 PREPARATION

- A. Moisten base to minimize absorption of water from fresh concrete.
- B. Coat surfaces of manholes, catch basins, and frames with oil to prevent bond with concrete pavement.
- C. Notify Architect/Engineer minimum 24 hours prior to commencement of concreting operations.

3.03 FORMING

- A. Place and secure forms to correct location, dimension, and profile.
- B. Assemble formwork to permit easy stripping and dismantling without damaging concrete.
- C. Place joint filler vertical in position, in straight lines. Secure to formwork during concrete placement.

3.04 REINFORCEMENT

- A. Place reinforcement at mid-height of slabs-on-grade.
- B. Interrupt reinforcement at expansion joints.
- C. Place dowels and reinforcement to achieve pavement and curb alignment as detailed.
- D. Provide doweled joints 12 inch o.c. at interruptions of concrete.

3.05 PLACING CONCRETE

- A. Place concrete in accordance with ACI 301.
- B. Ensure reinforcement, inserts, and embedded parts are not disturbed during concrete placement.
- C. Place concrete continuously between predetermined construction joints. Do not break or interrupt successive pours such that cold joints occur.
- D. Place concrete to indicated pattern.

3.06 JOINTS

- A. Place 1/2 inch expansion joints at 60 foot intervals. Align curb, gutter, and sidewalk joints.
- B. Place joint filler between paving components and building or other appurtenances. Recess top of filler 1/4 inch for sealant placement by Section 07900.
- C. Provide scored or sawn joints at 4 feet intervals U.N.O. at sidewalks and curbs and 15 feet at pavement.
- D. Saw cut contraction joints 3/16 inch wide at an optimum time after finishing. Cut 1/3 into depth of slab.

3.07 FINISHING

- A. Parking: Light broom.
- B. Sidewalk Paving: Light broom, radius to 1/4 inch and trowel joint edges.
- C. Handicapped Ramps: Reference ADA.
- D. Curbs and Gutters: Trowel finish.
- E. Inclined Vehicular Ramps: Broom perpendicular to slope.
- F. Place curing compound on exposed concrete surfaces immediately after finishing. Apply in accordance with manufacturer's instructions.

3.08 FIELD QUALITY CONTROL

- A. Three concrete test cylinders shall be taken for every 100 or less cu yds of each class of concrete placed each day.
- B. One additional test cylinder shall be taken during cold weather and cured on site under same conditions as concrete it represents.
- C. One slump test shall be taken for each set of test cylinders taken.

3.09 PROTECTION

- A. Immediately after placement, protect pavement from premature drying, excessive hot or cold temperatures, and mechanical injury.

3.10 SCHEDULES

- A. Concrete Sidewalks, Ramps, Stairs, and Retaining Walls: 3,000 psi 28 day concrete, 4 inches thick, 6x6 - 10x10 inch mesh reinforcement, natural color Portland cement, broom finish, detectable warnings per ADA at ramps and curb cuts.
- B. Concrete Aprons and Driveways: 4,000 psi 28 day concrete, 6 inches thick, 6x6 - 6x6 W.W.F. reinforced, natural color Portland cement, broom finish.

END OF SECTION 02520

SECTION 02810
IRRIGATION SYSTEMS

PART 1 - GENERAL

1.1 RELATED DOCUMENTS

- A. Drawings and general provisions of the Contract, including General and Supplementary Conditions and Division 1 Specification Sections, apply to this Section.

1.2 SUMMARY

- A. This Section includes a complete irrigation system including but not limited to; wells, pumps, piping, valves, sprinklers, heads, specialties, controls, and wiring for pumps and automatic control of the well pumps and irrigation system.
- B. Include all submittals, permits, and requirements associated with federal, state, and local requirements and regulations.

1.3 DEFINITIONS

- A. Retain abbreviations and definitions that remain after this Section has been edited.
- B. Circuit Piping: Downstream from control valves to sprinklers, specialties, and drain valves. Piping is under pressure during flow.
- C. Drain Piping: Downstream from circuit-piping drain valves. Piping is not under pressure.
- D. Irrigation Main Piping: Downstream from point of connection to water distribution piping to, and including, control valves. Piping is under water-distribution-system pressure.
- E. The following are industry abbreviations for plastic materials:
 - 1. ABS: Acrylonitrile-butadiene-styrene plastic.
 - 2. FRP: Fiberglass-reinforced plastic.
 - 3. PA: Polyamide (nylon) plastic.
 - 4. PE: Polyethylene plastic.
 - 5. PP: Polypropylene plastic.
 - 6. PTFE: Polytetrafluoroethylene plastic.
 - 7. PVC: Polyvinyl chloride plastic.
 - 8. TFE: Tetrafluoroethylene plastic.

1.4 PERFORMANCE REQUIREMENTS

- A. System must comply with the **City of Laramie's Unified Development Code, Title 15 (15.14.050)**.
- B. Test, Locate, and drill all wells, consistent with federal, state and local authorities and regulations. Design and size piping, controls and pumps consistent with federal, state, and local authorities and regulations. Provide shop drawings for approval.
- C. Design 100 percent water-coverage irrigation system for lawns and exterior plants indicated.
- D. Retain paragraph below if complete system design and calculations are in the Contract Documents.
- E. Location of Sprinklers and Specialties: Provide shop drawings for approval. Make minor adjustments necessary to avoid plantings and obstructions such as signs and light standards. Maintain 100 percent water coverage of turf and planting areas indicated.
- F. Retain paragraph and subparagraphs below with either paragraph above.
- G. Minimum Working Pressures: The following are minimum pressure requirements for piping, valves, and specialties, unless otherwise indicated:
 - 1. Irrigation Main Piping: 200 psig.
 - 2. Circuit Piping: 150 psig.
 - 3. Drain Piping: 100 psig.

1.5 SUBMITTALS

- A. Product Data: Include pressure ratings, rated capacities, and settings of selected models for the following:
 - 1. Water wells, pumps, regulators.
 - 2. Water hammer arresters.
 - 3. General-duty valves.
 - 4. Specialty valves.
 - 5. Control-valve boxes.
 - 6. Sprinklers.
 - 7. Irrigation specialties.
 - 8. Controllers. Include wiring diagrams.

9. Control cables. Include splice kits and conduit.

- B. Shop Drawings: Show well locations, pumps, irrigation system piping, including plan layout, and locations, types, sizes, capacities, and flow characteristics of irrigation system piping components. Include water meters, backflow preventers, valves, piping, sprinklers and devices, accessories, controls, and wiring. Show areas of sprinkler spray and overspray. Show wire size and number of conductors for each control cable.
- C. Coordination Drawings: Show piping and major system components. Indicate interface and spatial relationship between piping, system components, adjacent utilities, and proximate structures.
- D. Field quality-control test reports.
- E. Operation and Maintenance Data: For irrigation systems, to include in emergency, operation, and maintenance manuals. In addition to items specified in Division 1 Section "Closeout Procedures Operation and Maintenance Data," include data for the following:
 - 1. Automatic-control valves.
 - 2. Sprinklers.
 - 3. Controllers.
 - 4. Pumps and wells

1.6 QUALITY ASSURANCE

- A. Electrical Components, Devices, and Accessories: Listed and labeled as defined in NFPA 70, Article 100, by a testing agency acceptable to authorities having jurisdiction, and marked for intended use.

1.7 DELIVERY, STORAGE, AND HANDLING

- A. Deliver piping with factory-applied end caps. Maintain end caps through shipping, storage, and handling to prevent pipe-end damage and to prevent entrance of dirt, debris, and moisture.
- B. Store plastic piping protected from direct sunlight. Support to prevent sagging and bending.

1.8 COORDINATION

- A. Coordinate size and location of concrete bases. Cast anchor-bolt inserts into bases. Concrete, reinforcement, and formwork requirements are specified in Division 3.

1.9 EXTRA MATERIALS

- A. Furnish extra materials described below that match products installed and that are packaged with protective covering for storage and identified with labels describing contents.
 - 1. Sprinkler Units: 2 Each
 - 2. Emitter Units: 2 Each
 - 3. Drip Tube Units: 2 Each
 - 4. Valve Keys: 2 Each

PART 2 - PRODUCTS

2.1 MANUFACTURERS

- A. In other Part 2 articles where titles below introduce lists, the following requirements apply to product selection:
 - 1. Available Manufacturers: Subject to compliance with requirements, manufacturers offering products that may be incorporated into the Work include, but are not limited to, manufacturers specified.
 - 2. Manufacturers: Subject to compliance with requirements, provide products by one of the manufacturers specified.

2.2 PIPES, TUBES, AND FITTINGS

- A. PVC Pipe: ASTM D 1785, PVC 1120 compound, Schedule 40.
 - 1. PVC Socket Fittings, Schedule 40: ASTM D 2466.
- B. Transition Fittings: Refer to Division 2 Section "Piped Utilities -- Basic Materials and Methods" for transition fittings.
- C. Dielectric Fittings: Refer to Division 2 Section "Piped Utilities -- Basic Materials and Methods" for dielectric fittings.

2.3 JOINING MATERIALS

- A. Refer to Division 2 Section "Piped Utilities -- Basic Materials and Methods" for commonly used joining materials.

2.4 GENERAL-DUTY VALVES

- A. AWWA, Cast-Iron Gate Valves, nonrising-stem, gray- or ductile-iron body and bonnet gate valve; with bronze stem and stem nut.
 - 1. Minimum Working Pressure: 200 psig.
 - 2. End Connections: Mechanical joint.
 - 3. Interior Coating: Complying with AWWA C550.
- B. Valve Boxes: Comply with AWWA M44 for cast-iron valve boxes. Include top section, adjustable extension of length required for depth of burial of valve, plug with lettering "WATER," bottom section with base of size to fit over valve, and approximately 5-inch- diameter barrel.
 - 1. Operating Wrenches: Furnish total of two steel, tee-handle operating wrench (es) with one pointed end, stem of length to operate deepest buried valve, and socket matching valve operating nut.
- C. MSS, Cast-Iron, Nonrising-Stem Gate Valves: MSS SP-70, Type I, Class 125, with solid wedge and flanged ends. Include all bronze trim, cast-iron body, and handwheel.
- D. MSS, Cast-Iron, Rising-Stem Gate Valves: MSS SP-70, Type I, Class 125, with solid wedge and flanged ends. Include all bronze trim, cast-iron body, and handwheel.
- E. Curb Valves: AWWA C800. Include bronze body, ball or ground-key plug, and wide tee head, with inlet and outlet matching piping material.

2.5 SERVICE BOXES

- A. CURB VALVES: Similar to AWWA M44 requirements for cast-iron valve boxes. Include cast-iron telescoping top section of length required for depth of burial of valve, plug with lettering "WATER," bottom section with base of size to fit over curb valve, and approximately 3-inch- diameter barrel.
 - 1. Shutoff Rods: Furnish total of two steel, tee-handle shutoff rod(s) with one pointed end, stem of length to operate deepest buried valve, and slotted end matching curb valve.
- B. COPPER-ALLOY BALL VALVES: MSS SP-110, one-piece brass or bronze body with chrome-plated bronze ball, PTFE or TFE seats, and 400-psig minimum CWP rating.
- C. PVC BALL VALVES: MSS SP-122, union type, with full-port ball detachable end connectors, and pressure rating not less than 150 psig.
 - 1. Material Option: MSS SP-122, of plastic other than PVC and suitable for potable water. Include threaded ends and pressure rating not less than 150 psig, unless otherwise indicated.

2.6 CONTROL-VALVE BOXES

- A. Plastic Control-Valve Boxes: Box and cover, with open bottom and openings for piping; designed for installing flush with grade. Include size as required for valves and service.
- B. Drainage Backfill: Cleaned gravel or crushed stone, graded from 3/4 inch minimum to 3 inches maximum.

2.7 PIPING SPECIALTIES

- A. Water Regulators: ASSE 1003, single-seated, direct-operated, water-pressure regulators, rated for 150-psig minimum initial-inlet working pressure, with size, flow rate, and inlet and outlet pressures indicated. Include integral factory-installed or separate field-installed Y-pattern strainer that is compatible with unit for size and capacity.
- B. Water Hammer Arresters: ASSE 1010 or PDI WH 201, with bellows or piston-type pressurized cushioning chamber and in sizes complying with PDI WH 201, Sizes A to F.
- C. Pressure Gages: ASME B40.1. Include 4-1/2-inch- diameter dial, dial range of 2 times system operating pressure, and bottom outlet.

2.8 SPRINKLERS

- A. Description: Brass or plastic housing and corrosion-resistant interior parts designed for uniform coverage over entire spray area indicated, at available water pressure.
 - 1. Flush, Surface Sprinklers: Fixed pattern, with screw-type flow adjustment.
 - 2. Bubblers: Fixed pattern, with screw-type flow adjustment.
 - 3. Shrubbery Sprinklers: Fixed pattern, with screw-type flow adjustment.
 - 4. Pop-up, Spray Sprinklers: Fixed pattern, with screw-type flow adjustment and stainless-steel retraction spring.
 - 5. Pop-up, Rotary, Spray Sprinklers: Gear drive, full-circle and adjustable part-circle types.
 - 6. Pop-up, Rotary, Impact Sprinklers: Impact drive, full-circle, and part-circle types.

7. Aboveground, Rotary, Impact Sprinklers: Impact drive, full-circle, and part-circle types.

2.9 AUTOMATIC-CONTROL SYSTEM

- A. Exterior Control Enclosures: NEMA 250, Type 4, weatherproof, with locking cover and two matching keys; include provision for grounding.
- B. Control Transformer: 24-V secondary, with primary fuse.
- C. Controller Stations for Automatic Control Valves: Each station is variable from approximately 5 to 60 minutes. Include switch for manual or automatic operation of each station.
- D. Timing Device: Adjustable, 24-hour, 14-day clock, with automatic operations to skip operation any day in timer period, to operate every other day, or to operate 2 or more times daily.
 - 1. Manual or Semiautomatic Operation: Allows this mode without disturbing preset automatic operation.
 - 2. Nickel-Cadmium Battery and Trickle Charger: Automatically powers timing device during power outages.
 - 3. Surge Protection: Metal-oxide-varistor type on each station and primary power.
- E. Wiring: UL 493, Type UF-B multiconductor, with solid-copper conductors and insulated cable; suitable for direct burial.
 - 1. Feeder-Circuit Cables: No. 12 AWG minimum, between building and controllers.
 - 2. Low-Voltage, Branch-Circuit Cables: No. 14 AWG minimum, between controllers and automatic control valves; color-coded different from feeder-circuit-cable jacket color; with jackets of different colors for multiple-cable installation in same trench.
 - 3. Splicing Materials: Manufacturer's packaged kit consisting of insulating, spring-type connector or crimped joint and epoxy resin moisture seal; suitable for direct burial.
- F. Concrete Base: Reinforced precast concrete with opening for wiring.

PART 3 - EXECUTION

3.1 EARTHWORK

- A. Refer to Division 2 Section "Earthwork" for excavating, trenching, and backfilling.
- B. Install warning tape directly above pressure piping, 12 inches below finished grades, except 6 inches below subgrade under pavement and slabs.
- C. Install piping and wiring in sleeves under sidewalks, roadways, parking lots, and railroads.
 - 1. Install piping sleeves by boring or jacking under existing paving if possible.
- D. Drain Pockets: Excavate to sizes indicated. Backfill with cleaned gravel or crushed stone, graded from **3/4 to 3 inches**, to **12 inches** below grade. Cover gravel or crushed stone with sheet of asphalt-saturated felt and backfill remainder with excavated material.
- E. Provide minimum cover over top of underground piping according to the following:
 - 1. Irrigation Main Piping: Minimum depth of 36 inches below finished grade, or not less than 18 inches below average local frost depth, whichever is deeper.
 - 2. Circuit Piping: 12 inches.
 - 3. Drain Piping: 12 inches.
 - 4. Sleeves: 24 inches.

3.2 PREPARATION

- A. Set stakes to identify locations of proposed irrigation system. Obtain Architect's approval before excavation.

3.3 PIPING INSTALLATION

- A. Location and Arrangement: Drawings indicate location and arrangement of piping systems. Install piping as indicated unless deviations are approved on Coordination Drawings.
- B. Install piping at minimum uniform slope of 0.5 percent down toward drain valves.
- C. Install piping free of sags and bends.
- D. Install groups of pipes parallel to each other, spaced to permit valve servicing.
- E. Install fittings for changes in direction and branch connections.
- F. Install unions adjacent to valves and to final connections to other components with **NPS 2** or smaller pipe connection.
- G. Install flanges adjacent to valves and to final connections to other components with **NPS 2-1/2** or larger pipe connection.
- H. Install dielectric fittings to connect piping of dissimilar metals.
- I. Install underground thermoplastic piping according to ASTM D 2774.
- J. Lay piping on solid subbase, uniformly sloped without humps or depressions.
- K. Install ductile-iron piping according to AWWA C600.

- L. Install PVC piping in dry weather when temperature is above 40 deg F 5 deg C. Allow joints to cure at least 24 hours at temperatures above 40 deg F 5 deg C before testing unless otherwise recommended by manufacturer.
 - M. Install water regulators with shutoff valve and strainer on inlet and pressure gage on outlet. Install shutoff valve on outlet.
 - N. Water Hammer Arresters: Install between connection to building main and circuit valves in valve box.
- 3.4 JOINT CONSTRUCTION
- A. Refer to Division 2 Section "Piped Utilities -- Basic Materials and Methods" for basic pipe joint construction.
- 3.5 VALVE INSTALLATION
- A. Underground Gate Valves: Install in valve box with top flush with grade.
 - 1. Install valves and PVC pipe with restrained, gasketed joints.
 - B. Underground Curb Stops: Install in service box with top flush with grade.
 - C. Underground, Manual Control Valves: Install in manual control-valve box.
 - D. Control Valves: Install in control-valve box.
 - E. Drain Valves: Install in control-valve box.
- 3.6 SPRINKLER INSTALLATION
- A. Flush circuit piping with full head of water and install sprinklers after hydrostatic test is completed.
 - B. Install sprinklers at manufacturer's recommended heights.
 - C. Locate part-circle sprinklers to maintain a minimum distance of 4 inches from walls and 2 inches from other boundaries, unless otherwise indicated.
- 3.7 AUTOMATIC-CONTROL SYSTEM INSTALLATION
- A. Install freestanding controllers on precast concrete bases not less than 36 by 24 by 4 inches thick, and not less than 6 inches greater in each direction than overall dimensions of controller.
 - B. Install control cable in same trench as irrigation piping and at least 2 inches below piping. Provide conductors of size not smaller than recommended by controller manufacturer. Install cable in separate sleeve under paved areas if irrigation piping is installed in sleeve.
- 3.8 CONNECTIONS
- A. Drawings indicate general arrangement of piping, fittings, and specialties.
 - B. Ground equipment according to Division 16 Section "Grounding and Bonding."
 - C. Connect wiring according to Division 16 Section "Conductors and Cables."
 - D. Tighten electrical connectors and terminals according to manufacturer's published torque-tightening values. If manufacturer's torque values are not indicated, use those specified in UL 486A and UL 486B.
- 3.9 LABELING AND IDENTIFYING
- A. Equipment Nameplates and Signs: Install engraved plastic-laminate equipment nameplates and signs on each automatic controller.
 - 1. Text: In addition to identifying unit, distinguish between multiple units, inform operator of operational requirements, indicate safety and emergency precautions, and warn of hazards and improper operations.
 - B. Refer to Division 2 Section "Piped Utilities -- Basic Materials and Methods" for equipment nameplates and signs.
 - C. Warning Tapes: Arrange for installation of continuous, underground, detectable warning tape over underground piping, during backfilling of trenches.
 - D. Refer to Division 2 Section "Earthwork" for warning tapes.
- 3.10 FIELD QUALITY CONTROL
- A. Manufacturer's Field Service: Engage a factory-authorized service representative to inspect, test, and adjust field-assembled components and equipment installation, including connection, and to assist in field testing. Report results in writing.
 - B. Perform the following field tests and inspections and prepare test reports:
 - 1. Leak Test: After installation, charge system and test for leaks. Repair leaks and retest until no leaks exist.
 - 2. Operational Test: After electrical circuitry has been energized, operate controllers and automatic control valves to confirm proper system operation.

3. Test and adjust controls and safeties. Replace damaged and malfunctioning controls and equipment.
 - C. Remove and replace units and retest / reinspect as specified above.
- 3.11 STARTUP SERVICE
- A. Engage a factory-authorized service representative to perform startup service.
 - B. Verify that controllers are installed and connected according to the Contract Documents.
 - C. Verify that electrical wiring installation complies with manufacturer's submittal and installation requirements in Division 16 Sections.
 - D. Complete startup checks according to manufacturer's written instructions.
- 3.12 ADJUSTING
- A. Adjust settings of controllers.
 - B. Adjust automatic control valves to provide flow rate of rated operating pressure required for each sprinkler circuit.
 - C. Adjust sprinklers so they will be flush with, or not more than 1/2 inch above, finish grade.
- 3.13 CLEANING
- A. Flush dirt and debris from piping before installing sprinklers and other devices.
- 3.14 DEMONSTRATION
- A. Engage a factory-authorized service representative to train Owner's maintenance personnel to adjust, operate, and maintain controller and automatic control valves.

END OF SECTION 02810

SECTION 02920

LAWNS AND GRASSES

PART 1 - GENERAL

1.1 RELATED DOCUMENTS

- A. Drawings and general provisions of the Contract, including General and Supplementary Conditions and Division 1 Specification Sections, apply to this Section.

1.2 SUMMARY

- A. This Section includes the following:

- 1. Seeding.
- 2. Sodding.

- B. Related Sections include the following:

- 1. Division 2 Section "Site Clearing" for topsoil stripping and stockpiling.
- 2. Division 2 Section "Earthwork" for excavation, filling and backfilling, and rough grading.
- 3. Division 2 Section "Subdrainage" for subsurface drainage.

1.3 DEFINITIONS

- A. Finish Grade: Elevation of finished surface of planting soil.
- B. Manufactured Soil: Soil produced off-site by homogeneously blending mineral soils or sand with stabilized organic soil amendments to produce topsoil or planting soil.
- C. Planting Soil: Native or imported topsoil, manufactured topsoil, or surface soil modified to become topsoil; mixed with soil amendments.
- D. Subgrade: Surface or elevation of subsoil remaining after completing excavation, or top surface of a fill or backfill immediately beneath planting soil.

1.4 SUBMITTALS

- A. Product Data: For each type of product indicated.
- B. Certification of Grass Seed: From seed vendor for each grass-seed monostand or mixture stating the botanical and common name and percentage by weight of each species and variety, and percentage of purity, germination, and weed seed. Include the year of production and date of packaging.
- C. Qualification Data: For landscape Installer.
- D. Planting Schedule: Indicating anticipated planting dates for each type of planting.
- E. Maintenance Instructions: Recommended procedures to be established by Owner for maintenance of lawns during a calendar year. Submit before expiration of required maintenance periods.
- F. All Lawn and Grass products, varieties, species, installation practices, maintenance, etc. Shall comply with **City of Laramie's Unified Development Code, Title 15 (15.14.050)**.

1.5 QUALITY ASSURANCE

- A. Installer Qualifications: A qualified landscape installer whose work has resulted in successful lawn establishment.

1. Installer's Field Supervision: Require Installer to maintain an experienced full-time supervisor on Project site when planting is in progress.
- B. Soil-Testing Laboratory Qualifications: An independent laboratory, recognized by the State Department of Agriculture, with the experience and capability to conduct the testing indicated and that specializes in types of tests to be performed.
- C. Topsoil Analysis: Furnish soil analysis by a qualified soil-testing laboratory stating percentages of organic matter; gradation of sand, silt, and clay content; cation exchange capacity; deleterious material; pH; and mineral and plant-nutrient content of topsoil.
 1. Report suitability of topsoil for lawn growth. State recommended quantities of nitrogen, phosphorus, and potash nutrients and soil amendments to be added to produce a satisfactory topsoil.
- D. Preinstallation Conference: Conduct conference at Project site to comply with requirements in Division 1 Section "Project Management and Coordination."
- E. All Lawn and Grass products, varieties, species, installation practices, maintenance, etc. Shall comply with **City of Laramie's Unified Development Code, Title 15 (15.14.050)**.

1.6 DELIVERY, STORAGE, AND HANDLING

- A. Seed: Deliver seed in original sealed, labeled, and undamaged containers.
- B. Sod: Harvest, deliver, store, and handle sod according to requirements in TPI's "Specifications for Turfgrass Sod Materials" and "Specifications for Turfgrass Sod Transplanting and Installation" in its "Guideline Specifications to Turfgrass Sodding."

1.7 SCHEDULING

- A. Planting Restrictions: Plant according to manufacturer's recommendations. Coordinate planting periods with maintenance periods to provide required maintenance from date of Substantial Completion.
- B. Weather Limitations: Proceed with planting only when existing and forecasted weather conditions permit.

1.8 LAWN MAINTENANCE

- A. Begin maintenance immediately after each area is planted and continue until acceptable lawn is established, but for not less than the following periods:
 1. Seeded Lawns: 60 days from date of Substantial Completion.
 - a. When full maintenance period has not elapsed before end of planting season, or if lawn is not fully established, continue maintenance during next planting season.
- B. Maintain and establish lawn by watering, fertilizing, weeding, mowing, trimming, replanting, and other operations. Roll, regrade, and replant bare or eroded areas and remulch to produce a uniformly smooth lawn.
 1. In areas where mulch has been disturbed by wind or maintenance operations, add new mulch. Anchor as required to prevent displacement.
- C. Watering: Provide and maintain temporary piping, hoses, and lawn-watering equipment to convey water from sources and to keep lawn uniformly moist to a depth of 4 inches.
 1. Schedule watering to prevent wilting, puddling, erosion, and displacement of seed or mulch. Lay out temporary watering system to avoid walking over muddy or newly planted areas.
 2. Water lawn at a minimum rate of 1 inch per week.

- D. Mow lawn as soon as top growth is tall enough to cut. Repeat mowing to maintain specified height without cutting more than 40 percent of grass height. Remove no more than 40 percent of grass-leaf growth in initial or subsequent mowings. Do not delay mowing until grass blades bend over and become matted. Do not mow when grass is wet.
- E. Lawn Postfertilization: Apply fertilizer after initial mowing and when grass is dry.
 - 1. Use fertilizer that will provide actual nitrogen of at least 1 lb/1000 sq. ft. to lawn area.

PART 2 - PRODUCTS

2.1 SEED

- A. Grass Seed: Fresh, clean, dry, new-crop seed complying with AOSA's "Journal of Seed Technology; Rules for Testing Seeds" for purity and germination tolerances.
- B. Seed Species: Seed of grass species as follows, with not less than 95 percent germination, not less than 85 percent pure seed, and not more than 0.5 percent weed seed:
 - 1. Full Sun: Recommended species for area, soil, and climate.
 - 2. Sun and Partial Shade: Recommended species for area, soil, and climate
 - 3. Shade: Recommended species for area, soil, and climate.

2.2 TOPSOIL

- A. Topsoil: ASTM D 5268, pH range of 5.5 to 7, a minimum of 2 percent organic material content; free of stones 1/2 inch or larger in any dimension and other extraneous materials harmful to plant growth.
 - 1. Topsoil Source: Reuse surface soil stockpiled on-site. Verify suitability of stockpiled surface soil to produce topsoil. Clean surface soil of roots, plants, sod, stones, clay lumps, and other extraneous materials harmful to plant growth.
 - a. Supplement with imported or manufactured topsoil from off-site sources when quantities are insufficient. Obtain topsoil displaced from naturally well-drained construction or mining sites where topsoil occurs at least 4 inches deep; do not obtain from agricultural land, bogs, or marshes.
 - 2. Topsoil Source: Import topsoil or manufactured topsoil from off-site sources. Obtain topsoil displaced from naturally well-drained construction or mining sites where topsoil occurs at least 4 inches deep; do not obtain from agricultural land, bogs, or marshes.
 - 3. Topsoil Source: Amend existing in-place surface soil to produce topsoil. Verify suitability of surface soil to produce topsoil. Clean surface soil of roots, plants, sod, stones, clay lumps, and other extraneous materials harmful to plant growth.
 - a. Surface soil may be supplemented with imported or manufactured topsoil from off-site sources. Obtain topsoil displaced from naturally well-drained construction or mining sites where topsoil occurs at least 4 inches deep; do not obtain from agricultural land, bogs, or marshes.

2.3 PLANTING ACCESSORIES

- A. Selective Herbicides: EPA registered and approved, of type recommended by manufacturer for application.

2.4 FERTILIZER

- A. Bonemeal: Commercial, raw or steamed, finely ground; a minimum of 4 percent nitrogen and 10 percent phosphoric acid.
- B. Superphosphate: Commercial, phosphate mixture, soluble; a minimum of 20 percent available phosphoric acid.
- C. Commercial Fertilizer: Commercial-grade complete fertilizer of neutral character, consisting of fast- and slow-release nitrogen, 50 percent derived from natural organic sources of urea formaldehyde, phosphorous, and potassium in the following composition:
 - 1. Composition: 1 lb/1000 sq. ft. of actual nitrogen, 4 percent phosphorous, and 2 percent potassium, by weight.
 - 2. Composition: Nitrogen, phosphorous, and potassium in amounts recommended in soil reports from a qualified soil-testing agency.
- D. Slow-Release Fertilizer: Granular or pelleted fertilizer consisting of 50 percent water-insoluble nitrogen, phosphorus, and potassium in the following composition:
 - 1. Composition: 20 percent nitrogen, 10 percent phosphorous, and 10 percent potassium, by weight.
 - 2. Composition: Nitrogen, phosphorous, and potassium in amounts recommended in soil reports from a qualified soil-testing agency.

2.5 MULCHES

- A. Straw Mulch: Provide air-dry, clean, mildew- and seed-free, salt hay or threshed straw of wheat, rye, oats, or barley.
- B. Peat Mulch: Sphagnum peat moss, partially decomposed, finely divided, or granular texture, with a pH range of 3.4 to 4.8.
- C. Peat Mulch: Finely divided or granular texture, with a pH range of 6 to 7.5, containing partially decomposed moss peat, native peat, or reed-sedge peat and having a water-absorbing capacity of 1100 to 2000 percent.
- D. Compost Mulch: Well-composted, stable, and weed-free organic matter, pH range of 5.5 to 8; moisture content 35 to 55 percent by weight; 100 percent passing through 1-inch sieve; soluble salt content of 5 to 10 decisiemens/m; not exceeding 0.5 percent inert contaminants and free of substances toxic to plantings; and as follows:
 - 1. Organic Matter Content: 50 to 60 percent of dry weight.
 - 2. Feedstock: Agricultural, food, or industrial residuals; biosolids; yard trimmings; or source-separated or compostable mixed solid waste.
- E. Fiber Mulch: Biodegradable, dyed-wood, cellulose-fiber mulch; nontoxic; free of plant-growth or germination inhibitors; with maximum moisture content of 15 percent and a pH range of 4.5 to 6.5.
- F. Nonasphaltic Tackifier: Colloidal tackifier recommended by fiber-mulch manufacturer for slurry application; nontoxic and free of plant-growth or germination inhibitors.
- G. Asphalt Emulsion: ASTM D 977, Grade SS-1; nontoxic and free of plant-growth or germination inhibitors.

PART 3 - EXECUTION

3.1 EXAMINATION

- A. Examine areas to receive lawns and grass for compliance with requirements and other conditions affecting performance. Proceed with installation only after unsatisfactory conditions have been corrected.

3.2 PREPARATION

- A. Protect structures, utilities, sidewalks, pavements, and other facilities, trees, shrubs, and plantings from damage caused by planting operations.
 - 1. Protect adjacent and adjoining areas from hydroseeding overspray.
- B. Provide erosion-control measures to prevent erosion or displacement of soils and discharge of soil-bearing water runoff or airborne dust to adjacent properties and walkways.

3.3 LAWN PREPARATION

- A. Limit lawn subgrade preparation to areas to be planted.
- B. Newly Graded Subgrades: Loosen subgrade to a minimum depth of 4 inches. Remove stones larger than 1/2 inch in any dimension and sticks, roots, rubbish, and other extraneous matter and legally dispose of them off Owner's property.
 - 1. Apply fertilizer directly to subgrade before loosening.
 - 2. Thoroughly blend planting soil mix off-site before spreading or spread topsoil, apply soil amendments and fertilizer on surface, and thoroughly blend planting soil mix.
 - a. Delay mixing fertilizer with planting soil if planting will not proceed within a few days.
 - b. Mix lime with dry soil before mixing fertilizer.
 - 3. Spread planting soil mix to a depth of 4 inches but not less than required to meet finish grades after light rolling and natural settlement. Do not spread if planting soil or subgrade is frozen, muddy, or excessively wet.
 - a. Spread approximately one-half the thickness of planting soil mix over loosened subgrade. Mix thoroughly into top 2 inches of subgrade. Spread remainder of planting soil mix.
 - b. Reduce elevation of planting soil to allow for soil thickness of sod.
- C. Unchanged Subgrades: If lawns are to be planted in areas unaltered or undisturbed by excavating, grading, or surface soil stripping operations, prepare surface soil as follows:
 - 1. Remove existing grass, vegetation, and turf. Do not mix into surface soil.
 - 2. Loosen surface soil to a depth of at least of 6 inches. Apply soil amendments and fertilizers according to planting soil mix proportions and mix thoroughly into top 4 inches of soil. Till soil to a homogeneous mixture of fine texture.
 - 3. Remove stones larger than 1/2 inch in any dimension and sticks, roots, trash, and other extraneous matter.
 - 4. Legally dispose of waste material, including grass, vegetation, and turf, off Owner's property.
- D. Finish Grading: Grade planting areas to a smooth, uniform surface plane with loose, uniformly fine texture. Grade to within plus or minus 1/2 inch of finish elevation. Roll and rake, remove ridges, and fill depressions to meet finish grades. Limit fine grading to areas that can be planted in the immediate future.
- E. Moisten prepared lawn areas before planting if soil is dry. Water thoroughly and allow surface to dry before planting. Do not create muddy soil.
- F. Restore areas if eroded or otherwise disturbed after finish grading and before planting.

3.4 SEEDING

- A. Sow seed with spreader or seeding machine. Do not broadcast or drop seed when wind velocity exceeds 5 mph. Evenly distribute seed by sowing equal quantities in two directions at right angles to each other.
 - 1. Do not use wet seed or seed that is moldy or otherwise damaged.
- B. Sow seed at the rate of 3 to 4 lb/1000 sq. ft.
- C. Rake seed lightly into top 1/8 inch of topsoil, roll lightly, and water with fine spray.
- D. Protect seeded areas with slopes exceeding 1:6 with erosion-control fiber mesh and 1:4 with erosion-control blankets installed and stapled according to manufacturer's written instructions.
- E. Protect seeded areas with slopes not exceeding 1:6 by spreading straw mulch. Spread uniformly at a minimum rate of 2 tons/acre to form a continuous blanket 1-1/2 inches in loose depth over seeded areas. Spread by hand, blower, or other suitable equipment.
 - 1. Anchor straw mulch by crimping into topsoil with suitable mechanical equipment.
 - 2. Bond straw mulch by spraying with asphalt emulsion at the rate of 10 to 13 gal./1000 sq. ft.. Take precautions to prevent damage or staining of structures or other plantings adjacent to mulched areas. Immediately clean damaged or stained areas.
- F. Protect seeded areas from hot, dry weather or drying winds by applying any compost mulch, peat mulch, planting soil, or topsoil within 24 hours after completing seeding operations. Soak and scatter uniformly to a depth of 3/16 inch and roll to a smooth surface.

3.5 SATISFACTORY LAWNS

- A. Satisfactory Seeded Lawn: At end of maintenance period, a healthy, uniform, close stand of grass has been established, free of weeds and surface irregularities, with coverage exceeding 90 percent over any 10 sq. ft. and bare spots not exceeding 5 by 5 inches.
- B. Satisfactory Sodded Lawn: At end of maintenance period, a healthy, well-rooted, even-colored, viable lawn has been established, free of weeds, open joints, bare areas, and surface irregularities.
- C. Satisfactory Plugged Lawn: At end of maintenance period, the required number of plugs has been established as well-rooted, viable patches of grass; and areas between plugs are free of weeds and other undesirable vegetation.
- D. Satisfactory Sprigged Lawn: At end of maintenance period, the required number of sprigs has been established as well-rooted, viable plants; and areas between sprigs are free of weeds and other undesirable vegetation.
- E. Reestablish lawns that do not comply with requirements and continue maintenance until lawns are satisfactory.

3.6 CLEANUP AND PROTECTION

- A. Promptly remove soil and debris created by lawn work from paved areas. Clean wheels of vehicles before leaving site to avoid tracking soil onto roads, walks, or other paved areas.
- B. Erect barricades and warning signs as required to protect newly planted areas from traffic. Maintain barricades throughout maintenance period and remove after lawn is established.
- C. Remove erosion-control measures after grass establishment period.

END OF SECTION 02920

SECTION 02930

EXTERIOR PLANTS

PART 1 - GENERAL

1.1 RELATED DOCUMENTS

- A. Drawings and general provisions of the Contract, including General and Supplementary Conditions and Division 1 Specification Sections, apply to this Section.

1.2 SUMMARY

- A. This Section includes the following:

1. Trees.
2. Shrubs.
3. Ground cover.
4. Plants.
5. Edgings.
6. Planters.

- B. Related Sections include the following:

1. Division 2 Section "Site Clearing" for protection of existing trees and planting, topsoil stripping and stockpiling, and site clearing.
2. Division 2 Section "Earthwork" for excavation, filling, and rough grading and for subsurface aggregate drainage and drainage backfill materials.
3. Division 2 Section "Subdrainage" for below-grade drainage of landscaped areas, paved areas, and wall perimeters.

1.3 DEFINITIONS

- A. Balled and Burlapped Stock: Exterior plants dug with firm, natural balls of earth in which they are grown, wrapped, tied, rigidly supported, and drum-laced as recommended by ANSI Z60.1.
- B. Balled and Potted Stock: Exterior plants dug with firm, natural balls of earth in which they are grown and placed, unbroken, in a container.
- C. Bare-Root Stock: Exterior plants with a well-branched, fibrous-root system developed by transplanting or root pruning, with soil or growing medium removed, and with not less than minimum root spread according to ANSI Z60.1 for kind and size of exterior plant required.
- D. Container-Grown Stock: Healthy, vigorous, well-rooted exterior plants grown in a container with well-established root system reaching sides of container and maintaining a firm ball when removed from container. Container shall be rigid enough to hold ball shape and protect root mass during shipping and be sized according to ANSI Z60.1 for kind, type, and size of exterior plant required.
- E. Fabric Bag-Grown Stock: Healthy, vigorous, well-rooted exterior plants established and grown in-ground in a porous fabric bag with well-established root system reaching sides of fabric bag. Fabric bag size is not less than diameter, depth, and volume required by ANSI Z60.1 for type and size of exterior plant.
- F. Finish Grade: Elevation of finished surface of planting soil.

- G. **Manufactured Topsoil:** Soil produced off-site by homogeneously blending mineral soils or sand with stabilized organic soil amendments to produce topsoil or planting soil.
- H. **Planting Soil:** Native or imported topsoil, manufactured topsoil, or surface soil modified to become topsoil; mixed with soil amendments.
- I. **Subgrade:** Surface or elevation of subsoil remaining after completing excavation, or top surface of a fill or backfill, before placing planting soil.

1.4 SUBMITTALS

- A. **Product Data:** For each type of product indicated.
- B. **Samples for Verification:** For each of the following:
 1. 5 lb of mineral mulch for each color and texture of stone required, in labeled plastic bags.
 2. Edging materials and accessories, of manufacturer's standard size, to verify color selected.
- C. **Product Certificates:** For each type of manufactured product, signed by product manufacturer, and complying with the following:
 1. Manufacturer's certified analysis for standard products.
 2. Analysis of other materials by a recognized laboratory made according to methods established by the Association of Official Analytical Chemists, where applicable.
- D. **Qualification Data:** For landscape Installer.
- E. **Material Test Reports:** For existing surface soil and imported topsoil.
- F. **Planting Schedule:** Indicating anticipated planting dates for exterior plants. All plantings must comply with local landscape ordinances in type, size, and quantity. Final planting plan should be submitted to architect and the local city having jurisdiction for review and approval prior to the commencement of work.
- G. **Maintenance Instructions:** Recommended procedures to be established by Owner for maintenance of exterior plants during a calendar year. Submit before expiration of required maintenance periods.
- H. All plantings, sizes, varieties, species, locations, etc. shall comply with **The City of Laramie's Unified Development Code, Title 15 (15.14.050).**

1.5 QUALITY ASSURANCE

- A. **Installer Qualifications:** A qualified landscape installer whose work has resulted in successful establishment of exterior plants.
 1. **Installer's Field Supervision:** Require Installer to maintain an experienced full-time supervisor on Project site when exterior planting is in progress.
- B. **Soil-Testing Laboratory Qualifications:** An independent laboratory, recognized by the State Department of Agriculture, with the experience and capability to conduct the testing indicated and that specializes in types of tests to be performed.
- C. **Topsoil Analysis:** Furnish soil analysis by a qualified soil-testing laboratory stating percentages of organic matter; gradation of sand, silt, and clay content; cation exchange capacity; deleterious material; pH; and mineral and plant-nutrient content of topsoil.
 1. Report suitability of topsoil for plant growth. State recommended quantities of nitrogen, phosphorus, and potash nutrients and soil amendments to be added to produce a satisfactory topsoil.
- D. Provide quality, size, genus, species, and variety of exterior plants indicated, complying with applicable requirements in ANSI Z60.1, "American Standard for Nursery Stock."

1. Selection of exterior plants purchased under allowances will be made by Architect, who will tag plants at their place of growth before they are prepared for transplanting.
- E. Tree and Shrub Measurements: Measure according to ANSI Z60.1 with branches and trunks or canes in their normal position. Do not prune to obtain required sizes. Take caliper measurements 6 inches above ground for trees up to 4-inch caliper size, and 12 inches above ground for larger sizes. Measure main body of tree or shrub for height and spread; do not measure branches or roots tip-to-tip.
- F. Observation: Architect may observe trees and shrubs either at place of growth or at site before planting for compliance with requirements for genus, species, variety, size, and quality. Architect retains right to observe trees and shrubs further for size and condition of balls and root systems, insects, injuries, and latent defects and to reject unsatisfactory or defective material at any time during progress of work.
 1. Notify Architect of sources of planting materials seven days in advance of delivery to site.
- G. Preinstallation Conference: Conduct conference at Project site to comply with requirements in Division 1 Section "Project Management and Coordination."

1.6 DELIVERY, STORAGE, AND HANDLING

- A. Deliver exterior plants freshly dug.
 1. Immediately after digging up bare-root stock, pack root system in wet straw, hay, or other suitable material to keep root system moist until planting.
- B. Do not prune trees and shrubs before delivery, except as approved by Architect. Protect bark, branches, and root systems from sun scald, drying, sweating, whipping, and other handling and tying damage. Do not bend or bind-tie trees or shrubs in such a manner as to destroy their natural shape. Provide protective covering of exterior plants during delivery. Do not drop exterior plants during delivery.
- C. Handle planting stock by root ball.
- D. Deliver exterior plants after preparations for planting have been completed and install immediately. If planting is delayed more than six hours after delivery, set exterior plants trees in shade, protect from weather and mechanical damage, and keep roots moist.
 1. Heel-in bare-root stock. Soak roots in water for two hours if dried out.
 2. Set balled stock on ground and cover ball with soil, peat moss, sawdust, or other acceptable material.
 3. Do not remove container-grown stock from containers before time of planting.
 4. Water root systems of exterior plants stored on-site with a fine-mist spray. Water as often as necessary to maintain root systems in a moist condition.

1.7 COORDINATION

- A. Planting Restrictions: Plant during one of the following periods. Coordinate planting periods with maintenance periods to provide required maintenance from date of Substantial Completion.
 1. Spring Planting: As recommended for area, soil, and climate.
 2. Fall Planting: As recommended for area, soil, and climate.
- B. Weather Limitations: Proceed with planting only when existing and forecasted weather conditions permit.
- C. Coordination with Lawns: Plant trees and shrubs after finish grades are established and before planting lawns, unless otherwise acceptable to Architect.
 1. When planting trees and shrubs after lawns, protect lawn areas and promptly repair damage caused by planting operations.

1.8 WARRANTY

- A. Special Warranty: Warrant the following exterior plants, for the warranty period indicated, against defects including death and unsatisfactory growth, except for defects resulting from lack of adequate maintenance, neglect, or abuse by Owner, or incidents that are beyond Contractor's control.
 1. Warranty Period for Trees and Shrubs: One year from date of Substantial Completion.

2. Warranty Period for Ground Cover and Plants: Six months from date of Substantial Completion.
3. Remove dead exterior plants immediately. Replace immediately unless required to plant in the succeeding planting season.
4. Replace exterior plants that are more than 25 percent dead or in an unhealthy condition at end of warranty period.
5. A limit of one replacement of each exterior plant will be required, except for losses or replacements due to failure to comply with requirements.

1.9 MAINTENANCE

- A. Trees and Shrubs: Maintain for the following maintenance period by pruning, cultivating, watering, weeding, fertilizing, restoring planting saucers, tightening and repairing stakes and guy supports, and resetting to proper grades or vertical position, as required to establish healthy, viable plantings. Spray as required to keep trees and shrubs free of insects and disease. Restore or replace damaged tree wrappings.
 1. Maintenance Period: Six months from date of Substantial Completion.
- B. Ground Cover and Plants: Maintain for the following maintenance period by watering, weeding, fertilizing, and other operations as required to establish healthy, viable plantings:
 1. Maintenance Period: Six months from date of Substantial Completion.

PART 2 - PRODUCTS

2.1 TREE AND SHRUB MATERIAL

- A. General: Furnish nursery-grown trees and shrubs complying with ANSI Z60.1, with healthy root systems developed by transplanting or root pruning. Provide well-shaped, fully branched, healthy, vigorous stock free of disease, insects, eggs, larvae, and defects such as knots, sun scald, injuries, abrasions, and disfigurement.
- B. Grade: Provide trees and shrubs of sizes and grades complying with ANSI Z60.1 for type of trees and shrubs required. Trees and shrubs of a larger size may be used if acceptable to Architect, with a proportionate increase in size of roots or balls.
- C. Label each tree and shrub with securely attached, waterproof tag bearing legible designation of botanical and common name.
- D. Label at least one tree and one shrub of each variety and caliper with a securely attached, waterproof tag bearing legible designation of botanical and common name.
- E. If formal arrangements or consecutive order of trees or shrubs is shown, select stock for uniform height and spread, and number label to assure symmetry in planting.

2.2 SHADE AND FLOWERING TREES

- A. Small Trees: Branched or pruned naturally according to species and type, with relationship of caliper, height, and branching according to ANSI Z60.1.
- B. Multistem Trees: Branched or pruned naturally according to species and type, with relationship of caliper, height, and branching according to ANSI Z60.1.

2.3 DECIDUOUS SHRUBS

- A. Form and Size: Deciduous shrubs with not less than the minimum number of canes required by and measured according to ANSI Z60.1 for type, shape, and height of shrub.

2.4 CONIFEROUS EVERGREENS

- A. Form and Size: Normal-quality, well-balanced, coniferous evergreens, of type, height, spread, and shape required, complying with ANSI Z60.1.

2.5 BROADLEAF EVERGREENS

- A. Form and Size: Normal-quality, well-balanced, broadleaf evergreens, of type, height, spread, and shape required, complying with ANSI Z60.1.

2.6 GROUND COVER PLANTS

- A. Ground Cover: Provide ground cover of species indicated, established and well rooted in pots or similar containers, and complying with ANSI Z60.1.
- B. Dichondra: Provide dichondra seed with 99 percent minimum pure seed, not less than 85 percent germination, and not more than 0.25 percent weed seed.
- C. Dichondra: Provide dichondra plants grown in flats and suitable for cutting into plugs.

2.7 PLANTS

- A. Annuals: Provide healthy, disease-free plants of species and variety shown or listed. Provide only plants that are acclimated to outdoor conditions before delivery and that are in bud but not yet in bloom.
- B. Perennials: Provide healthy, field-grown plants from a commercial nursery, of species and variety shown or listed.
- C. Fast-Growing Vines: Provide vines of species indicated complying with requirements in ANSI Z60.1 as follows:
 - 1. Two-year plants with heavy, well-branched tops, with not less than 3 runners 18 inches or more in length, and with a vigorous well-developed root system.
 - 2. Provide field-grown vines. Vines grown in pots or other containers of adequate size and acclimated to outside conditions will also be acceptable.

2.8 TOPSOIL

- A. Topsoil: ASTM D 5268, pH range of 5.5 to 7, a minimum of 4 percent organic material content; free of stones 1/2 inch or larger in any dimension and other extraneous materials harmful to plant growth.
 - 1. Topsoil Source: Reuse surface soil stockpiled on-site. Verify suitability of stockpiled surface soil to produce topsoil. Clean surface soil of roots, plants, sod, stones, clay lumps, and other extraneous materials harmful to plant growth.
 - a. Supplement with imported or manufactured topsoil from off-site sources when quantities are insufficient. Obtain topsoil displaced from naturally well-drained construction or mining sites where topsoil occurs at least 4 inches deep; do not obtain from agricultural land, bogs, or marshes.
 - 2. Topsoil Source: Import topsoil or manufactured topsoil from off-site sources. Obtain topsoil displaced from naturally well-drained construction or mining sites where topsoil occurs at least 4 inches deep; do not obtain from agricultural land, bogs, or marshes.
 - 3. Topsoil Source: Amend existing in-place surface soil to produce topsoil. Verify suitability of surface soil to produce topsoil. Clean surface soil of roots, plants, sod, stones, clay lumps, and other extraneous materials harmful to plant growth.
 - a. Surface soil may be supplemented with imported or manufactured topsoil from off-site sources. Obtain topsoil displaced from naturally well-drained construction or mining sites where topsoil occurs at least 4 inches deep; do not obtain from agricultural land, bogs, or marshes.

2.9 ORGANIC SOIL AMENDMENTS

- A. Compost: Well-composted, stable, and weed-free organic matter, pH range of 5.5 to 8; moisture content 35 to 55 percent by weight; 100 percent passing through 1-inch sieve; soluble salt content of 5 to 10 decisiemens/m; not exceeding 0.5 percent inert contaminants and free of substances toxic to plantings.

- B. Peat: Sphagnum peat moss, partially decomposed, finely divided, or granular texture, with a pH range of 3.4 to 4.8.
- C. Peat: Finely divided or granular texture, with a pH range of 6 to 7.5, containing partially decomposed moss peat, native peat, or reed-sedge peat and having a water-absorbing capacity of 1100 to 2000 percent.
- D. Wood Derivatives: Decomposed, nitrogen-treated sawdust, ground bark, or wood waste; of uniform texture, free of chips, stones, sticks, soil, or toxic materials.
- E. Manure: Well-rotted, unleached, stable or cattle manure containing not more than 25 percent by volume of straw, sawdust, or other bedding materials; free of toxic substances, stones, sticks, soil, weed seed, and material harmful to plant growth.

2.10 FERTILIZER

- A. Bonemeal: Commercial, raw or steamed, finely ground; a minimum of 4 percent nitrogen and 10 percent phosphoric acid.
- B. Superphosphate: Commercial, phosphate mixture, soluble; a minimum of 20 percent available phosphoric acid.
- C. Commercial Fertilizer: Commercial-grade complete fertilizer of neutral character, consisting of fast- and slow-release nitrogen, 50 percent derived from natural organic sources of urea formaldehyde, phosphorous, and potassium in the following composition:
 1. Composition: 1 lb/1000 sq. ft of actual nitrogen, 4 percent phosphorous, and 2 percent potassium, by weight.
 2. Composition: Nitrogen, phosphorous, and potassium in amounts recommended in soil reports from a qualified soil-testing agency.
- D. Slow-Release Fertilizer: Granular or pelleted fertilizer consisting of 50 percent water-insoluble nitrogen, phosphorus, and potassium in the following composition:
 1. Composition: 20 percent nitrogen, 10 percent phosphorous, and 10 percent potassium, by weight.
 2. Composition: Nitrogen, phosphorous, and potassium in amounts recommended in soil reports from a qualified soil-testing agency.

2.11 MULCHES

- A. Organic Mulch: Free from deleterious materials and suitable as a top dressing of trees and shrubs.
- B. Compost Mulch: Well-composted, stable, and weed-free organic matter, pH range of 5.5 to 8; moisture content 35 to 55 percent by weight; 100 percent passing through 1-inch sieve; soluble salt content of 5 to 10 decisiemens/m; not exceeding 0.5 percent inert contaminants and free of substances toxic to plantings.

2.12 WEED-CONTROL BARRIERS

- A. Polyethylene Sheeting: ASTM D 4397, black, 0.006-inch- minimum thickness.
- B. Nonwoven Fabric: Polypropylene or polyester fabric, 3 oz./sq. yd. minimum.
- C. Composite Fabric: Woven, needle-punched polypropylene substrate bonded to a nonwoven polypropylene fabric, 4.8 oz./sq. yd.

2.13 STAKES AND GUYS

- A. Upright and Guy Stakes: Rough-sawn, sound, new hardwood, redwood, or pressure-preservative-treated softwood, free of knots, holes, cross grain, and other defects, 2 by 2 inches by length indicated, pointed at one end.

- B. Guy and Tie Wire: ASTM A 641/A 641M, Class 1, galvanized-steel wire, 2-strand, twisted, 0.106 inch in diameter.
- C. Guy Cable: 5-strand, 3/16-inch- diameter, galvanized-steel cable, with zinc-coated turnbuckles, a minimum of 3 inches long, with two 3/8-inch galvanized eyebolts.
- D. Hose Chafing Guard: Reinforced rubber or plastic hose at least 1/2 inch in diameter, black, cut to lengths required to protect tree trunks from damage.
- E. Flags: Standard surveyor's plastic flagging tape, white, 6 inches long.

2.14 LANDSCAPE EDGINGS

- A. Wood Edging: Of sizes shown, and wood stakes.
- B. Steel Edging: Standard commercial-steel edging, rolled edge, fabricated in sections of standard lengths, with loops stamped from, or welded to face of sections to receive stakes.
- C. Aluminum Edging: Standard-profile extruded-aluminum edging, ASTM B 221, alloy 6063-T6, fabricated in standard lengths with interlocking sections with loops stamped from face of sections to receive stakes.
- D. Polyethylene Edging: Standard black polyethylene edging, V-lipped bottom, extruded in standard lengths, with 9-inch steel angle stakes.

PART 3 - EXECUTION

3.1 EXAMINATION

- A. Examine areas to receive exterior plants for compliance with requirements and conditions affecting installation and performance. Proceed with installation only after unsatisfactory conditions have been corrected.

3.2 PREPARATION

- A. Protect structures, utilities, sidewalks, pavements, and other facilities, and lawns and existing exterior plants from damage caused by planting operations.
- B. Provide erosion-control measures to prevent erosion or displacement of soils and discharge of soil-bearing water runoff or airborne dust to adjacent properties and walkways.
- C. Lay out individual tree and shrub locations and areas for multiple exterior plantings. Stake locations, outline areas, adjust locations when requested, and obtain Architect's acceptance of layout before planting. Make minor adjustments as required.
- D. Lay out exterior plants at locations directed by Architect. Stake locations of individual trees and shrubs and outline areas for multiple plantings.
- E. Apply antidesiccant to trees and shrubs using power spray to provide an adequate film over trunks, branches, stems, twigs, and foliage to protect during digging, handling, and transportation.
 1. If deciduous trees or shrubs are moved in full leaf, spray with antidesiccant at nursery before moving and again two weeks after planting.

3.3 PLANTING BED ESTABLISHMENT

- A. Loosen subgrade of planting beds to a minimum depth of 4 inches. Remove stones larger than 1/2 inch in any dimension and sticks, roots, rubbish, and other extraneous matter and legally dispose of them off Owner's property.
- B. Finish Grading: Grade planting beds to a smooth, uniform surface plane with loose, uniformly fine texture. Roll and rake, remove ridges, and fill depressions to meet finish grades.

- C. Restore planting beds if eroded or otherwise disturbed after finish grading and before planting.

3.4 TREE AND SHRUB EXCAVATION

- A. Pits and Trenches: Excavate circular pits with sides sloped inward. Trim base leaving center area raised slightly to support root ball and assist in drainage. Do not further disturb base. Scarify sides of plant pit smeared or smoothed during excavation.
 - 1. Excavate approximately three times as wide as ball diameter for balled and burlapped stock.
 - 2. Excavate at least **12 inches** wider than root spread and deep enough to accommodate vertical roots for bare-root stock.
 - 3. If drain tile is shown or required under planted areas, excavate to top of porous backfill over tile.
- B. Subsoil removed from excavations may be used as backfill.
- C. Obstructions: Notify Architect if unexpected rock or obstructions detrimental to trees or shrubs are encountered in excavations.
 - 1. Hardpan Layer: Drill **6-inch** diameter holes into free-draining strata or to a depth of **10 feet**, whichever is less, and backfill with free-draining material.
- D. Drainage: Notify Architect if subsoil conditions evidence unexpected water seepage or retention in tree or shrub pits.
- E. Fill excavations with water and allow to percolate away before positioning trees and shrubs.

3.5 TREE AND SHRUB PLANTING

- A. Set balled and burlapped stock plumb and in center of pit or trench with top of root ball flush with adjacent finish grades.
 - 1. Remove burlap and wire baskets from tops of root balls and partially from sides, but do not remove from under root balls. Remove pallets, if any, before setting. Do not use planting stock if root ball is cracked or broken before or during planting operation.
 - 2. Place planting soil mix around root ball in layers, tamping to settle mix and eliminate voids and air pockets. When pit is approximately one-half backfilled, water thoroughly before placing remainder of backfill. Repeat watering until no more water is absorbed. Water again after placing and tamping final layer of planting soil mix.
- B. Set balled and potted stock plumb and in center of pit or trench with top of root ball flush with adjacent finish grades.
 - 1. Carefully remove root ball from container without damaging root ball or plant.
 - 2. Place planting soil mix around root ball in layers, tamping to settle mix and eliminate voids and air pockets. When pit is approximately one-half backfilled, water thoroughly before placing remainder of backfill. Repeat watering until no more water is absorbed. Water again after placing and tamping final layer of planting soil mix.
- C. Set fabric bag-grown stock plumb and in center of pit or trench with top of root ball flush with adjacent finish grades.
 - 1. Carefully remove root ball from fabric bag without damaging root ball or plant. Do not use planting stock if root ball is cracked or broken before or during planting operation.
 - 2. Place planting soil mix around root ball in layers, tamping to settle mix and eliminate voids and air pockets. When pit is approximately one-half backfilled, water thoroughly before placing remainder of backfill. Repeat watering until no more water is absorbed. Water again after placing and tamping final layer of planting soil mix.
- D. Set and support bare-root stock in center of pit or trench with root collar or trunk flare, flush with adjacent finish grade. Spread roots without tangling or turning toward surface, and carefully work backfill around roots by hand. Puddle with water until backfill layers are completely saturated. Plumb before backfilling, and maintain plumb while working backfill around roots and placing layers above roots. Tamp final layer of backfill. Remove injured roots by cutting cleanly; do not break.
- E. Organic Mulching: Apply 2-inch average thickness of organic mulch extending 12 inches beyond edge of planting pit or trench. Do not place mulch within 3 inches of trunks or stems.

- F. Wrap trees of 2-inch caliper and larger with trunk-wrap tape. Start at base of trunk and spiral cover trunk to height of first branches. Overlap wrap, exposing half the width, and securely attach without causing girdling. Inspect tree trunks for injury, improper pruning, and insect infestation; take corrective measures required before wrapping.

3.6 TREE AND SHRUB PRUNING

- A. Prune, thin, and shape trees and shrubs as directed by Architect.
- B. Prune, thin, and shape trees and shrubs according to standard horticultural practice. Prune trees to retain required height and spread. Unless otherwise indicated by Architect, do not cut tree leaders; remove only injured or dead branches from flowering trees. Prune shrubs to retain natural character. Shrub sizes indicated are sizes after pruning.

3.7 GUYING AND STAKING

- A. Upright Staking and Tying: Stake trees of 2- through 5-inch caliper. Stake trees of less than 2-inch caliper only as required to prevent wind tip-out. Use a minimum of 2 stakes of length required to penetrate at least 18 inches below bottom of backfilled excavation and to extend at least 72 inches above grade. Set vertical stakes and space to avoid penetrating root balls or root masses. Support trees with two strands of tie wire encased in hose sections at contact points with tree trunk. Allow enough slack to avoid rigid restraint of tree. Use the number of stakes as follows:
 - 1. Use 2 stakes for trees up to 12 feet high and 2-1/2 inches or less in caliper; 3 stakes for trees less than 14 feet high and up to 4 inches in caliper. Space stakes equally around trees.
- B. Guying and Staking: Guy and stake trees exceeding 14 feet in height and more than 3 inches in caliper, unless otherwise indicated. Securely attach no fewer than 3 guys to stakes 30 inches long, driven to grade.
 - 1. For trees more than 6 inches in caliper, anchor guys to pressure-preservative-treated deadmen 8 inches in diameter and 48 inches long buried at least 36 inches below grade. Provide turnbuckles for each guy wire and tighten securely.
 - 2. Attach flags to each guy wire, 30 inches above finish grade.
 - 3. Paint turnbuckles with luminescent white paint.

3.8 PLANTERS

- A. Planters: Place a layer of gravel at least 4 inches thick in bottom of planters, cover with nonwoven fabric, and fill with planter soil mix. Place soil in lightly compacted layers to an elevation of 1-1/2 inches below top of planter, allowing natural settlement.
 - 1. Planter Soil Mix: One part topsoil, one part coarse sand, one part peat, and 3 lb of dolomitic limestone per cubic yard of mix.

3.9 GROUND COVER AND PLANT PLANTING

- A. Set out and space ground cover and plants as indicated or recommended.
- B. Dig holes large enough to allow spreading of roots, and backfill with planting soil.
- C. Work soil around roots to eliminate air pockets and leave a slight saucer indentation around plants to hold water.
- D. Water thoroughly after planting, taking care not to cover plant crowns with wet soil.
- E. Protect plants from hot sun and wind; remove protection if plants show evidence of recovery from transplanting shock.

3.10 PLANTING BED MULCHING

- A. Install weed-control barriers before mulching according to manufacturer's written instructions. Completely cover area to be mulched, overlapping edges a minimum of 6 inches.
- B. Mulch backfilled surfaces of planting beds and other areas indicated.

1. Organic Mulch: Apply 2-inch average thickness of organic mulch, and finish level with adjacent finish grades. Do not place mulch against plant stems.
2. Mineral Mulch: Apply 2-inch average thickness of mineral mulch, and finish level with adjacent finish grades. Do not place mulch against plant stems.

3.11 EDGING INSTALLATION

- A. Wood Edgings: Install wood headers or edgings where indicated. Anchor with wood stakes spaced up to **36 inches** apart, driven at least **1 inch** below top elevation of header or edging. Use 2 galvanized nails per stake to fasten headers and edging; length as needed to penetrate both members and provide **1/2-inch** clinch at point. Pre-drill stakes if needed to avoid splitting.
- B. Steel Edging: Install steel edging where indicated according to manufacturer's written instructions. Anchor with steel stakes spaced approximately 30 inches apart, driven below top elevation of edging.
- C. Aluminum Edging: Install aluminum edging where indicated according to manufacturer's written instructions. Anchor with aluminum stakes spaced approximately 36 inches apart, driven below top elevation of edging.
- D. Plastic Edging: Install plastic edging where indicated according to manufacturer's written instructions. Anchor with steel stakes spaced approximately 36 inches apart, driven through upper base grooves or V-lip of edging.

3.12 TREE GRATE INSTALLATION

- A. Tree Grates: Set grate segments flush with adjoining surfaces as shown on Drawings. Shim from supporting substrate with soil-resistant plastic. Maintain a **3-inch- (75-mm-)** minimum growth radius around base of tree; break away units of casting, if necessary, according to manufacturer's written instructions.

3.13 CLEANUP AND PROTECTION

- A. During exterior planting, keep adjacent pavings and construction clean and work area in an orderly condition.
- B. Protect exterior plants from damage due to landscape operations, operations by other contractors and trades, and others. Maintain protection during installation and maintenance periods. Treat, repair, or replace damaged exterior planting.

3.14 DISPOSAL

- A. Disposal: Remove surplus soil and waste material, including excess subsoil, unsuitable soil, trash, and debris, and legally dispose of them off Owner's property.

END OF SECTION 02930

SECTION 03100
CONCRETE FORMWORK

PART 1 GENERAL

1.01 SECTION INCLUDES

- A. Formwork for cast-in place concrete, with shoring, bracing, and anchorage.
- B. Openings for other work.
- C. Form accessories.
- D. Form stripping.

1.02 DELIVERY, STORAGE, AND HANDLING

- A. Deliver, store, protect, and handle products to site per the suppliers and/or manufacturer's recommendations.
- B. Store off ground in ventilated and protected manner to prevent deterioration from moisture.

1.03 COORDINATION

- A. Coordinate this Section with other Sections of work which require attachment of components to formwork.
- B. If formwork is placed after reinforcement resulting in insufficient concrete cover over reinforcement before proceeding, request instructions from Architect/Engineer.

PART 2 PRODUCTS

2.01 WOOD FORM MATERIALS

- A. Form Materials: At the discretion of the Contractor.

2.02 PREFABRICATED FORMS

- A. Preformed Steel Forms: Minimum gage matched, tight fitting, stiffened to support weight of concrete without deflection detrimental to tolerances and appearance of finished surfaces.
- B. Glass Fiber Fabric Reinforced Plastic Forms: Matched, tight fitting, stiffened to support weight of concrete without deflection detrimental to tolerances and appearance of finished concrete surfaces.

2.03 FORMWORK ACCESSORIES

- A. Form Ties: Removable or Snap-off type, metal, size and shape to minimize filling, waterproofing, and refinishing concrete surfaces.
- B. Form Release Agent: Colorless mineral oil which will not stain concrete, or absorb moisture, or impair natural bonding or color characteristics of coating intended for use on concrete.
- C. Corners: Chamfer, exposed edges 1/2 inch unless otherwise noted or detailed on the drawings.
- D. Dovetail Anchor Slot: Galvanized steel, 22 gage thick, release tape sealed slots, anchors for securing to concrete formwork.
- E. Flashing Reglets: Galvanized steel 22 gage thick, longest possible lengths, with alignment splines for joints, release tape sealed slots, anchors for securing to concrete formwork.
- F. Nails, Spikes, Lag Bolts, Through Bolts, Anchorages: Sized as required, of sufficient strength and character to maintain formwork in place while placing concrete.
- G. Waterstops: Rubber Polyvinyl chloride, minimum 1,750 psi tensile strength, minimum 50 degrees F to plus 175 degrees F working temperature range, maximum possible lengths, ribbed profile, preformed corner sections, heat welded jointing.

PART 3 EXECUTION

3.01 EXAMINATION

- A. Verify lines, levels, and centers before proceeding with formwork. Ensure that dimensions agree with drawings.

3.02 EARTH FORMS

- A. Earth forms if permitted, hand trim sides and bottom of earth forms. Remove loose soil prior to placing concrete.

3.03 ERECTION - FORMWORK

- A. Erect formwork, shoring, and bracing to achieve design requirements, in accordance with requirements of ACI 301.

- B. Provide bracing to ensure stability of formwork. Shore or strengthen formwork subject to over stressing by construction loads.
 - C. Arrange and assemble formwork to permit dismantling and stripping. Do not damage concrete during stripping. Permit removal of remaining principal shores.
 - D. Align joints and make watertight. Keep form joints to a minimum.
 - E. Obtain approval before framing openings in structural members which are not indicated on Drawings.
 - F. Provide chamfer strips on external corners of beams joists columns and exposed decorative concrete edges.
 - G. Install void forms in accordance with manufacturer's recommendations. Protect forms from moisture or crushing.
- 3.04 APPLICATION - FORM RELEASE AGENT
- A. Apply form release agent on formwork in accordance with manufacturer's recommendations.
 - B. Apply prior to placement of reinforcing steel, anchoring devices, and embedded items.
 - C. Do not apply form release agent where concrete surfaces will receive special finishes or applied coverings which are affected by agent. Soak inside surfaces of untreated forms with clean water. Keep surfaces coated prior to placement of concrete.
- 3.05 INSERTS, EMBEDDED PARTS, AND OPENINGS
- A. Provide formed openings where required for items to be embedded in passing through concrete work.
 - B. Locate and set in place items which will be cast directly into concrete.
 - C. Coordinate with work of other sections in forming and placing openings, slots, reglets, recesses, sleeves, bolts, anchors, other inserts, and components of other Work.
 - D. Position recessed reglets for brick veneer masonry anchors to spacing and intervals specified in Section 04300.
 - E. Install accessories in accordance with manufacturer's instructions, straight, level, and plumb. Ensure items are not disturbed during concrete placement.
 - F. Install waterstops continuous without displacing reinforcement. Heat seal joints watertight.
 - G. Provide temporary ports or openings in formwork where required to facilitate cleaning and inspection. Locate openings at bottom of forms to allow flushing water to drain.
 - H. Close temporary openings with tight fitting panels, flush with inside face of forms, and neatly fitted so joints will not be apparent in exposed concrete surfaces.
- 3.06 FORM CLEANING
- A. Clean forms as erection proceeds, to remove foreign matter within forms.
 - B. Clean formed cavities of debris prior to placing concrete.
 - C. Flush with water or use compressed air to remove remaining foreign matter. Ensure that water and debris drain to exterior through clean-out ports.
 - D. During cold weather, remove ice and snow from within forms. Do not use de-icing salts. Do not use water to clean out forms, unless formwork and concrete construction proceed within heated enclosure. Use compressed air or other means to remove foreign matter.
- 3.07 FORMWORK TOLERANCES
- A. Construct formwork to maintain tolerances required by ACI 301. Construct and align formwork for elevator hoistway in accordance with ANSI/ASME A17.1.
- 3.08 FIELD QUALITY CONTROL
- A. Inspect erected formwork, shoring, and bracing to ensure that work is in accordance with formwork design, and that supports, fastenings, wedges, ties, and items are secure.
 - B. Do not reuse wood formwork more than 2 times for concrete surfaces to be exposed to view. Do not patch formwork.
- 3.09 FORM REMOVAL
- A. Do not remove forms or bracing until concrete has gained sufficient strength to carry its own weight and
 - B. Loosen forms carefully. Do not wedge pry bars, hammers, or tools against finish concrete surfaces scheduled for exposure to view.
 - C. Store removed forms in manner that surfaces to be in contact with fresh concrete will not be damaged. Discard damaged forms.

END OF SECTION 03100

SECTION 03200
CONCRETE REINFORCEMENT

PART 1 GENERAL

1.01 SECTION INCLUDES

- A. Reinforcing steel bars, wire fabric, and accessories for cast-in-place concrete.

1.02 SUBMITTALS

- A. Submit under provisions of the General Requirements.
- B. Shop Drawings: Indicate bar sizes, spacings, locations, and quantities of reinforcing steel and wire fabric, bending and cutting schedules, and supporting and spacing devices.

1.03 QUALITY ASSURANCE

- A. Perform Work in accordance with CRSI - Manual of Standard Practice and ACI 301.

1.04 QUALIFICATIONS

- A. Design reinforcement under direct supervision of a Professional Structural Engineer experienced in design of this work and licensed in the State of Kansas.

1.05 COORDINATION

- A. Coordinate with placement of formwork, formed openings and other Work.

PART 2 PRODUCTS

2.01 REINFORCEMENT

- A. Reinforcing Steel: ASTM A615, 40, 60, or 75 ksi yield grade as indicated on the drawings; deformed billet steel bars, unfinished.
- B. Reinforcing Steel Plain Bar and Rod Mats: ASTM A704, ASTM A615, Grade 40 or 60 as indicated on the drawings; steel bars or rods, unfinished.
- C. Stirrup Steel: ANSI/ASTM A82, unfinished.
- D. Welded Steel Wire Fabric: ASTM A815; in flat sheets or coiled rolls; unfinished.

2.02 ACCESSORY MATERIALS

- A. Tie Wire: Minimum 16 gage annealed type.
- B. Chairs, Bolsters, Bar Supports, Spacers: Sized and shaped for strength and support of reinforcement during concrete placement conditions including load bearing pad on bottom to prevent vapor barrier puncture.
- C. Special Chairs, Bolsters, Bar Supports, Spacers Adjacent to Weather Exposed Concrete Surfaces: Plastic coated steel type; size and shape as required.

2.03 FABRICATION

- A. Fabricate concrete reinforcing in accordance with CRSI Manual of Practice.
- B. Weld reinforcement in accordance with ANSI/AWS D1.4.
- C. Locate reinforcing splices not indicated on drawings, at point of minimum stress.

PART 3 EXECUTION

3.01 PLACEMENT

- A. Place, support and secure reinforcement against displacement. Do not deviate from required position.
- B. Do not displace or damage vapor barrier.
- C. Accommodate placement of formed openings.

D. Maintain concrete cover around reinforcing as indicated on the drawings or if not indicated as follows:

<u>Item</u>	<u>Coverage</u>
Beams	1 1/2 inch
Column Ties	1 1/2 inch
Walls (exposed to weather or backfill)	2 inch
Footings and Concrete Formed Against Earth	3 inch
Slabs on Fill	3/4 inch

END OF SECTION 03200

SECTION 03300

CAST-IN-PLACE CONCRETE

PART 1 GENERAL

1.01 SECTION INCLUDES

- A. Cast-in-place concrete floors, foundation walls, retaining walls, steps and ramps.
- B. Floors and slabs on grade.
- C. Control, expansion, and contraction joint devices associated with concrete work, including joint sealants.
- D. Equipment pads, light pole base and flagpole base.

1.02 SUBMITTALS

- A. Submit under provisions of the General Requirements.
- B. Product Data: For each of the following.
 - 1. Joint devices
 - 2. Attachment accessories.
 - 3. Portland cement.
 - 4. Fly ash.
 - 5. Slag cement.
 - 6. Blended hydraulic cement.
 - 7. Silica fume.
 - 8. Performance-based hydraulic cement.
 - 9. Aggregates.
 - 10. Amixtures.
 - a. Include limitations of use, including restrictions on cementitious materials, supplementary cementitious materials, air entrainment, aggregates, temperature at time of concrete placement, relative humidity at time of concrete placement, curing conditions, and use of other admixtures.
 - 11. Vapor retarders.
 - 12. Curing materials.
- C. Samples: Submit 2-inch long samples of expansion/contraction joint & vapor retarder.
- D. Manufacturer's Installation Instructions: Indicate installation procedures and interface required with adjacent Work.
- E. Design Mixtures: For each concrete mixture, include the following:
 - 1. Mixture identification.
 - 2. Minimum 28-day compressive strength.
 - 3. Durability exposure class.
 - 4. Maximum w/cm.
 - 5. Slump limit.
 - 6. Air content.
 - 7. Nominal maximum aggregate size.
 - 8. Steel-fiber reinforcement content.
 - 9. Synthetic micro-fiber content.
 - 10. Indicate amounts of mixing water to be withheld for later addition at Project site if permitted.
 - 11. Intended placement method.
 - 12. Submit alternate design mixtures when characteristics of materials, Project conditions, weather, test results, or other circumstances warrant adjustments.
- F. Shop Drawings:
 - 1. Construction Joint Layout: Indicate proposed construction joints required to construct the structure.
 - a. Location of construction joints is subject to approval of the Architect.
- G. Informational submittals:
 - 1. Qualification Data: For the installer (include copies of applicable ACI certificates), Ready-mix concrete manufacturer, testing agency (include copies of applicable ACI certificates).

1.03 PROJECT RECORD DOCUMENTS

- A. Accurately record actual locations of embedded utilities and components which are concealed from view.

1.04 QUALITY ASSURANCE

- A. Perform Work in accordance with ACI 301.
- B. Acquire cement and aggregate from same source for all work.
- C. Conform to ACI 305R when concreting during hot weather.
- D. Conform to ACI 306R when concreting during cold weather.

1.05 COORDINATION

- A. Coordinate the placement of joint devices with erection of concrete formwork and placement of form accessories.

PART 2 PRODUCTS

2.01 CONCRETE MATERIALS

- A. Cement: ASTM C150, Type I - Normal or Type III - High Early Strength Type V - Sulfate Resistant as required Portland type.
- B. Fine and Coarse Aggregates: ASTM C33 Class 3S coarse aggregate or better, graded. Provide aggregates from a single source.
 - 1. Maximum coarse aggregate size: 1 inch nominal
 - 2. Fine aggregate: Free of materials with deleterious reactivity to alkali in cement.
- C. Water: Clean and not detrimental to concrete. ASTM C94 potable.

2.02 ADMIXTURES

- A. Air Entrainment: ASTM C260.
- B. Chemical: ASTM C494 Type A - Water Reducing, Type B - Retarding, Type C - Accelerating, Type D - Water Reducing and Retarding, Type E - Water Reducing and Accelerating.

2.03 ACCESSORIES

- A. Bonding Agent: Polymer resin emulsion, polyvinyl acetate, Latex emulsion, two component modified epoxy resin, non-solvent two component polysulfide epoxy, mineral filled polysulfide polymer epoxy, mineral filled polysulfide polymer epoxy resin, or Polyamid cured epoxy as approved.
- B. Vapor Barrier: 12 mil thick clear polyethylene film, type recommended for below grade application.
- C. Non-Shrink Grout: Premixed compound consisting of nonmetallic aggregate, cement, water reducing and plasticizing agents; capable of developing minimum compressive strength of 2,400 psi in 48 hours and 7,000 psi in 28 days.

2.04 JOINT DEVICES AND FILLER MATERIALS

- A. Joint Filler:
 - 1. Joint Filler Type A: ASTM D1751; Asphalt impregnated fiberboard or felt, 1/4 inch thick.
 - 2. Joint Filler Type B: ASTM D1752; Closed cell polyvinyl chloride foam, resiliency recovery of 95 percent if not compressed more than 50 percent of original thickness.
- B. Expansion and Contraction Joint Devices: ASTM B221 alloy, extruded aluminum; resilient elastomeric, vinyl, or neoprene, filler strip with a Shore A hardness of 35 to permit plus or minus 25 percent joint movement with full recovery; extruded aluminum or vinyl cover plate, of longest manufactured length at each location, recess mounted; color as selected.
- C. Sealant: Rubber or synthetic rubber compound.

2.05 CONCRETE MIX

- A. Class A: Normal-weight concrete used for footings, and foundation walls.
 - 1. Exposure Class: ACI 318 F2
 - 2. Mix concrete in accordance with ACI 304. Deliver concrete in accordance with ASTM C94.
 - 3. Select proportions for normal weight concrete in accordance with ACI 301.
 - 4. Provide concrete with compressive strength of 5,000 psi at 28 days.
 - 5. Use accelerating admixtures in cold weather only when approved by Architect/Engineer. Use of admixtures will not relax cold weather placement requirements.
 - 6. Use calcium chloride only when approved by Architect/Engineer.
 - 7. Use set retarding admixtures during hot weather only when approved by Architect/Engineer.
 - 8. Add air entraining agent to normal weight concrete mix for work exposed to exterior.
 - 9. Maximum w/cm: 0.45
 - 10. Slump Limit: 5 inches, plus or minus 1 inch.
 - 11. Slump Flow Limit: 22 inches, plus or minus 1.5 inches

12. Air content: 6% plus or minus 1% at point of delivery
- B. Class B: Normal-weight concrete used for slabs-on-grade.
1. Exposure Class: ACI 318 F0
 2. Mix concrete in accordance with ACI 304. Deliver concrete in accordance with ASTM C94.
 3. Select proportions for normal weight concrete in accordance with ACI 301.
 4. Provide concrete with compressive strength of 4,000 psi at 28 days.
 5. Use accelerating admixtures in cold weather only when approved by Architect/Engineer. Use of admixtures will not relax cold weather placement requirements.
 6. Use calcium chloride only when approved by Architect/Engineer.
 7. Use set retarding admixtures during hot weather only when approved by Architect/Engineer.
 8. Add air entraining agent to normal weight concrete mix for work exposed to exterior.
 9. Maximum w/cm: 0.5
 10. Slump Limit: 5 inches, plus or minus 1 inch.
 11. Slump Flow Limit: 22 inches, plus or minus 1.5 inches
 12. Air content: Do not use an air-entraining admixture or allow total air content to exceed 3% for concrete used in trowel-finished floors.

PART 3 EXECUTION

3.01 EXAMINATION

- A. Verify requirements for concrete cover over reinforcement.
- B. Verify that anchors, seats, plates, reinforcement and other items to be cast into concrete are accurately placed, positioned securely, and will not cause hardship in placing concrete.

3.02 PREPARATION

- A. Prepare previously placed concrete by cleaning with steel brush and applying bonding agent in accordance with manufacturer's instructions.
- B. In locations where new concrete is dowelled to existing work, drill holes in existing concrete, insert steel dowels and pack solid with non-shrink grout.

3.03 PLACING CONCRETE

- A. Place concrete in accordance with ACI 301.
- B. Notify Architect/Engineer minimum 24 hours prior to commencement of operations.
- C. Ensure reinforcement, inserts, embedded parts, formed expansion, and contraction joints are not disturbed during concrete placement.
- D. Install vapor barrier under interior slabs on grade in accordance with ASTM E1643 and manufacturer's written instructions. Lap joints minimum 6 inches and seal watertight by sealant applied between overlapping edges and ends or taping edges and ends.
- E. Repair vapor barrier damaged during placement of concrete reinforcing. Repair with vapor barrier material; lap over damaged areas minimum 6 inches and seal watertight.
- F. Separate slabs on grade from vertical surfaces with 1/2 inch thick joint filler.
- G. Place joint filler in floor slab pattern placement sequence. Set top to required elevations. Secure to resist movement by wet concrete.
- H. Extend joint filler from bottom of slab to within 1/2 inch of finished slab surface. Conform to Section 07900 for finish joint sealer requirements.
- I. Install joint devices in accordance with manufacturer's instructions.
- J. Install construction joint devices in coordination with floor slab pattern placement sequence. Set top to required elevations. Secure to resist movement by wet concrete.
- K. Install joint device anchors. Maintain correct position to allow joint cover to be flush with floor and wall finish.
- L. Install joint covers in longest practical length, when adjacent construction activity is complete.
- M. Apply sealants in joint devices in accordance with Section 07900.
- N. Maintain records of concrete placement. Record date, location, quantity, air temperature, and test samples taken.
- O. Place concrete continuously between predetermined expansion, control, and construction joints.
- P. Do not interrupt successive placement; do not permit cold joints to occur where possible.
- Q. Place floor slabs in checkerboard or saw cut pattern indicated.
- R. Saw cut joints within 24 hours after placing. Use 3/16 inch thick blade, cut into 1/4 depth of slab thickness.
- S. Screed floors and slabs on grade level, maintaining surface flatness of maximum 1/4 inch in 10 ft.

3.04 CONCRETE FINISHING

- A. Provide formed concrete surfaces to be left exposed concrete walls columns beams joists with smooth rubbed finish.
- B. Finish concrete floor surfaces in accordance with ACI 301.
- C. Wood float surfaces which will receive quarry tile, ceramic tile, or terrazzo with full bed setting system.
- D. Steel trowel surfaces which will receive carpeting, resilient flooring, seamless flooring, thin set quarry tile, or thin set ceramic tile.
- E. Steel trowel surfaces which are scheduled to be exposed.
- F. In areas with floor drains, maintain floor elevation at walls; pitch surfaces uniformly to drains at 1/4 inch per foot or as indicated on drawings.

3.05 CURING AND PROTECTION

- A. Immediately after placement, protect concrete from premature drying, excessively hot or cold temperatures, and mechanical injury.
- B. Maintain concrete with minimal moisture loss at relatively constant temperature for period necessary for hydration of cement and hardening of concrete.
- C. Cure floor surfaces in accordance with ACI 308.
- D. Ponding: Maintain 100 percent coverage of water over floor slab areas continuously for 4 days.
- E. Spraying: Spray water over floor slab areas and maintain wet for 7 days.

3.06 FIELD QUALITY CONTROL

- A. Field inspection and testing will be performed in accordance with ACI 301 and under provisions of the General Requirements.
- B. Provide free access to Work and cooperate with appointed firm.
- C. Submit proposed mix design of each class of concrete to inspection and testing firm for review prior to commencement of Work.
- D. Tests of cement and aggregates may be performed to ensure conformance with specified requirements.
- E. Three concrete test cylinders will be taken for every 75 or less cu yds of each class of concrete placed.
- F. One additional test cylinder will be taken during cold weather concreting, cured on job site under same conditions as concrete it represents.
- G. One slump test will be taken for each set of test cylinders taken.

3.07 PATCHING

- A. Allow Architect/Engineer to inspect concrete surfaces immediately upon removal of forms.
- B. Excessive honeycomb or embedded debris in concrete is not acceptable. Notify Architect/Engineer upon discovery.
- C. Patch imperfections as directed or in accordance with ACI 301.

3.08 DEFECTIVE CONCRETE

- A. Defective Concrete: Concrete not conforming to required lines, details, dimensions, tolerances or specified requirements.
- B. Repair or replacement of defective concrete will be determined by the Architect/Engineer.
- C. Do not patch, fill, touch-up, repair, or replace exposed concrete except upon express direction of Architect/Engineer for each individual area.

END OF SECTION 03300

SECTION 035216

LIGHTWEIGHT INSULATING CONCRETE

PART 1 - GENERAL

1.1 SUMMARY

- A. Section Includes:
 - 1. Cast-in-place cellular foam lightweight insulating concrete.

1.2 ACTION SUBMITTALS

- A. Product Data: For each type of product.
- B. Shop drawings.
- C. Design mixtures.

1.3 INFORMATIONAL SUBMITTALS

- A. Product certificates.
- B. Evaluation reports.

1.4 QUALITY ASSURANCE

- A. Installer Qualifications: An entity that employs installers and supervisors who are trained and approved by manufacturer.

PART 2 - PRODUCTS

2.1 CELLULAR LIGHTWEIGHT INSULATING CONCRETE

- A. Produce cellular lightweight insulating concrete with the following minimum physical properties using cementitious materials, air-producing liquid-foaming agents complying with ASTM C869/C869M, and the minimum amount of water necessary to produce a workable mix:
 - 1. As-Cast Unit Weight: **34 to 42 lb/cu. ft. (545 to 673 kg/cu. m)** at point of placement, when tested according to ASTM C138/C138M.
 - 2. Oven-Dry Unit Weight: **26 to 32 lb/cu. ft. (416 to 513 kg/cu. m)**, when tested according to ASTM C495.
 - 3. Compressive Strength: Minimum **190 psi (1310 kPa)**, when tested according to ASTM C495.

2.2 MATERIALS

- A. Cementitious Material: Portland cement, ASTM C150/C150M, **Type I**
- B. Water: Clean, potable.
- C. Joint Filler: ASTM C612, Class 2, glass-fiber type; compressing to one-half thickness under a load of **25 psi (172 kPa)**.
- D. Steel Wire Mesh: Cold-drawn steel wire, galvanized, **0.041-inch (1.04-mm)** diameter, woven into **2-inch (50-mm)** hexagonal mesh, and reinforced with a longitudinal **0.062-inch- (1.57-mm-)** diameter wire spaced **3 inches (75 mm)** apart.

2.3 DESIGN MIXTURES

- A. Prepare design mixtures for each type and strength of lightweight insulating concrete by laboratory trial batch method or by field-test data method. For trial batch method, use a qualified independent testing agency for preparing and reporting proposed mixture designs.
 - 1. Limit use of fly ash to not exceed 25 percent of portland cement by weight.

- B. Limit water-soluble chloride ions to the maximum percentage by weight of cement or cementitious material permitted by **ACI 301 (ACI 301M)**.

PART 3 - EXECUTION

3.1 PREPARATION

- A. Control Joints: Install control joints at perimeter of roof deck and at junctures with vertical surfaces, including curbs, walls, and vents, for full depth of lightweight insulating concrete. Fill control joints with joint filler.
 - 1. Provide **1-inch- (25-mm-)** wide control joints for roof dimensions up to **100 feet (30 m)** in length; **1-1/2-inch- (38-mm-)** wide control joints for roof dimensions exceeding **100 feet (30 m)**.
- B. Wire Mesh: Place steel wire mesh with longest dimension perpendicular to steel deck ribs. Cut mesh to fit around roof openings and projections. Terminate mesh at control joints. Lap sides and ends of mesh at least **6 inches (150 mm)**.
- C. Welded Wire Reinforcement: Place steel welded wire reinforcement with longest dimension perpendicular to steel deck ribs. Cut reinforcement to fit around roof openings and projections. Terminate reinforcement at control joints. Lap sides and ends of reinforcement at least **6 inches (150 mm)**.

3.2 MIXING AND PLACING

- A. Mix and place lightweight insulating concrete according to manufacturer's written instructions, using equipment and procedures to avoid segregation of mixture and loss of air content.
- B. Install insulation board according to lightweight insulating concrete manufacturer's written instructions. Place insulation board in wet, lightweight insulating concrete slurry poured a minimum of **1/8 inch (3 mm)** over the structural substrate. Ensure full contact of insulation board with slurry. Stagger joints and tightly butt insulation boards. Allow slurry coat to set prior to placing remaining thickness of lightweight insulating concrete.
 - 1. Install insulation board in a stair-step configuration with a maximum step-down of **1 inch (25 mm)**.
- C. Deposit and screed lightweight insulating concrete in a continuous operation until an entire panel or section of roof area is completed. Do not vibrate or work mix except for screeding or floating. Place to depths and slopes indicated.
- D. Finish top surface smooth, free of ridges and depressions, and maintain surface in condition to receive subsequent roofing system.
- E. Begin curing operations immediately after placement, and air cure for not less than three days, according to manufacturer's written instructions.
- F. If ambient temperature falls below **32 deg F (0 deg C)**, protect lightweight insulating concrete from freezing and maintain temperature recommended by manufacturer for 72 hours after placement.

END OF SECTION 035216

SECTION 035413

GYPSUM CEMENT UNDERLAYMENT

PART 1 - GENERAL

1.1 RELATED DOCUMENTS

- A. Drawings and general provisions of the Contract, including General and Supplementary Conditions and Division 01 Specification Sections, apply to this Section.

1.2 SUMMARY

- A. Section includes two gypsum-cement-based, self-leveling underlayments for application below interior floor coverings: Gyp-Crete, 2000 min psi at residential units & Dura-Cap, 2500 min psi at higher traffic areas.
- B. Floor Assembly includes Acoustic matt to achieve a min. STC rating of 50.
- C. Related Sections:
 - 1. Division 09 Sections for patching and leveling compounds applied with floor coverings.

1.3 ALLOWANCES

- A. Furnish gypsum-cement-based underlayment as part of underlayment allowance.
- B. Furnish and install gypsum-cement-based underlayment as part of underlayment allowance.

1.4 SUBMITTALS

- A. Product Data: For each type of product indicated.
- B. Shop Drawings: Include plans indicating substrates, locations, and average depths of underlayment based on survey of substrate conditions.
- C. Qualification Data: For qualified Installer.
- D. Product Certificates: Signed by manufacturers of underlayment and floor-covering systems certifying that products are compatible

1.5 QUALITY ASSURANCE

- A. Installer Qualifications: Installer who is approved by manufacturer for application of underlayment products required for this Project.
- B. Product Compatibility: Manufacturers of underlayment and floor-covering systems certify in writing that products are compatible.
- C. Fire-Resistance Ratings: Where indicated, provide gypsum-cement underlayment systems identical to those of assemblies tested for fire resistance per ASTM E 119 by a qualified testing agency. Identify products with appropriate markings of applicable testing agency.
 - 1. Indicate design designations from UL's "Fire Resistance Directory" or from the listings of another qualified testing agency.
- D. Sound Transmission Characteristics: Where indicated, provide gypsum-cement underlayment systems identical to those of assemblies tested for STC and IIC ratings per ASTM E 90 and ASTM E 492 by a qualified testing agency.

1.6 DELIVERY, STORAGE, AND HANDLING

- A. Store materials to comply with manufacturer's written instructions to prevent deterioration from moisture or other detrimental effects.

1.7 PROJECT CONDITIONS

- A. Environmental Limitations: Comply with manufacturer's written instructions for substrate temperature, ventilation, ambient temperature and humidity, and other conditions affecting underlayment performance.
 - 1. Place gypsum-cement-based underlayments only when ambient temperature and temperature of substrates are between 50 and 80 deg F (10 and 27 deg C).

1.8 COORDINATION

- A. Coordinate application of underlayment with requirements of floor-covering products and adhesives, specified in Division 09 Sections, to ensure compatibility of products.

PART 2 - PRODUCTS

2.1 GYPSUM-CEMENT-BASED UNDERLAYMENTS

- A. Underlayment: Gypsum-cement-based, self-leveling product that can be applied in minimum uniform thickness of **1/8 inch (3 mm)** and that can be feathered at edges to match adjacent floor elevations. Floor Assembly includes Acoustic Matt to achieve a min. STC rating of 50.
1. Products: Subject to compliance with requirements, **provide the following:**
 - a. Maxxon Corporation; **Gyp-Crete 2000**, at all residential units
 - b. Maxxon Corporation; **Dura-Cap**, at public areas and hallways
See schedule end of spec.
- Or as submitted and approved equal below;
- c. Allied Custom Gypsum;
 - d. Bonsal American, an Oldcastle company;
 - e. CMP Specialty Products, Inc.;
 - f. Euclid Chemical Company (The);
 - g. Hacker Industries, Inc.;
 - h. USG Corporation;
2. Cement Binder: Gypsum or blended gypsum cement as defined by ASTM C 219.
 3. Compressive Strength:
 - a. **Gyp-Crete 2000**; Typical range 2000 – 3200 psi at 28 days when tested according to ASTM C 109/C 109M, use at residential areas.
 - b. **Dura-Cap**; Typical range 2500 – 4000 psi at 28 days when tested according to ASTM C 109/C 109M, use at higher traffic areas.
 4. Underlayment Additive: Resilient-emulsion product of underlayment manufacturer, formulated for use with underlayment when applied to substrate and conditions indicated.
- B. Sound Mat:
1. Products: Subject to compliance with requirements, **provide one of the following:**
 - a. Maxxon Corporation; Acousti Mat, 1/8” to achieve **STC rating of 50**.
 - b. Submitted as approved equal, 1/8” to achieve **STC rating of 50**.
- C. Aggregate: Well-graded, washed gravel, **1/8 to 1/4 inch (3 to 6 mm)**; or coarse sand as recommended by underlayment manufacturer.
1. Provide aggregate when recommended in writing by underlayment manufacturer for underlayment thickness required.
- D. Water: Potable and at a temperature of not more than **70 deg F (21 deg C)**.
- E. Reinforcement: For underlayment applied to wood substrates, provide galvanized metal lath or other corrosion-resistant reinforcement recommended in writing by underlayment manufacturer.
- F. Primer: Product of underlayment manufacturer recommended in writing for substrate, conditions, and application indicated.
- G. Corrosion-Resistant Coating: Recommended in writing by underlayment manufacturer for metal substrates.
- H. Rigid Insulation:
1. Extruded polystyrene with a minimum density 1.8 pcf (8.8 kg/m³) Type VI, Owens Corning Foamular 400 High compressive Strength Rigid Foam Insulation or approved equal. Insulation must meet ASTM C578. When the Gyp-Crete 2000/3.2K thickness is 1 inch (25 mm) to less than 1½ inches (38 mm), the polystyrene board must have 1 inch (25 mm) [minimum] diameter holes 12 inches (305 mm) on center maximum in all directions for support pedestals.
- I. Overspray Primer Sealer:
1. Seal all areas that receive glue down floor goods with Maxxon Overspray according to manufacturer's specifications.
- J. Acrylic Primer Sealer (Alternate to Overspray):
1. Seal all areas that receive glue down floor goods with Maxxon Acrylic according to manufacturer's specifications.

PART 3 - EXECUTION

3.1 EXAMINATION

- A. Examine substrates, with Installer present, for conditions affecting performance.
 - 1. Proceed with application only after unsatisfactory conditions have been corrected.

3.2 PREPARATION

- A. General: Prepare and clean substrate according to manufacturer's written instructions.
 - 1. Treat nonmoving substrate cracks according to manufacturer's written instructions to prevent cracks from telegraphing (reflecting) through underlayment.
 - 2. Fill substrate voids to prevent underlayment from leaking.
- B. Concrete Substrates: Mechanically remove, according to manufacturer's written instructions, laitance, glaze, efflorescence, curing compounds, form-release agents, dust, dirt, grease, oil, and other contaminants that might impair underlayment bond.
 - 1. Moisture Testing: Perform anhydrous calcium chloride test, ASTM F 1869. Proceed with installation only after substrates do not exceed a maximum moisture-vapor-emission rate of [3 lb of water/1000 sq. ft. (1.36 kg of water/100 sq. m)] in 24 hours.
- C. Wood Substrates: Mechanically fasten loose boards and panels to eliminate substrate movement and squeaks. Sand to remove coatings that might impair underlayment bond and remove sanding dust.
 - 1. Install underlayment reinforcement recommended in writing by manufacturer.
- D. Metal Substrates: Mechanically remove, according to manufacturer's written instructions, rust, foreign matter, and other contaminants that might impair underlayment bond. Apply corrosion-resistant coating compatible with underlayment if recommended in writing by underlayment manufacturer.
- E. Nonporous Substrates: For ceramic tile, quarry tile, and terrazzo substrates, remove waxes, sealants, and other contaminants that might impair underlayment bond, and prepare surfaces according to manufacturer's written instructions.
- F. Adhesion Tests: After substrate preparation, test substrate for adhesion with underlayment according to manufacturer's written instructions.
- G. Sound Control **Mat**: Install sound control materials according to manufacturer's written instructions.
 - 1. Do not install mechanical fasteners that penetrate through the sound control materials.

3.3 APPLICATION

- A. General: Mix and apply underlayment components according to manufacturer's written instructions.
 - 1. Close areas to traffic during underlayment application and for time period after application recommended in writing by manufacturer.
 - 2. Coordinate application of components to provide optimum underlayment-to-substrate and intercoat adhesion.
 - 3. At substrate expansion, isolation, and other moving joints, allow joint of same width to continue through underlayment.
- B. Apply primer over prepared substrate at manufacturer's recommended spreading rate.
- C. Apply underlayment to produce uniform, level surface.
 - 1. Apply a final layer without aggregate to product surface.
 - 2. Feather edges to match adjacent floor elevations.
- D. Cure underlayment according to manufacturer's written instructions. Prevent contamination during application and curing processes.
- E. Do not install floor coverings over underlayment until after time period recommended in writing by underlayment manufacturer.
- F. Remove and replace underlayment areas that evidence lack of bond with substrate, including areas that emit a "hollow" sound when tapped.

3.4 PROTECTION

- A. Protect underlayment from concentrated and rolling loads for remainder of construction period.

END OF SECTION 035413

SECTION 04100

MORTAR AND MASONRY GROUT

PART 1 GENERAL

- 1.01 SECTION INCLUDES
- A. Mortar and grout for masonry
- 1.02 GENERAL
- A. All notes or specifications on structural drawings shall override any discrepancies listed.
- 1.03 SUBMITTALS
- A. Submit under provisions of the General Requirements.
 - B. Include design mix, indicate whether the Proportion or Property specification of ASTM C270 is to be used, required environmental conditions, and admixture limitations.
- 1.04 QUALITY ASSURANCE
- A. Perform Work in accordance with ACI 530 and ACI 530.1 .
- 1.05 DELIVERY, STORAGE, AND HANDLING
- A. Deliver, store, protect, and handle products to site under provisions of the General Requirements.
 - B. Maintain packaged materials clean, dry, and protected against dampness, freezing, and foreign matter.
- 1.06 ENVIRONMENTAL REQUIREMENTS
- A. Maintain materials and surrounding air temperature to minimum 40 degrees F prior to, during, and 48 hours after completion of masonry work.
 - B. Maintain materials and surrounding air temperature to maximum 90 degrees F prior to, during, and 48 hours after completion of masonry work.

PART 2 PRODUCTS

- 2.01 MATERIALS
- A. Portland Cement: ASTM C150, Type I.
 - B. Masonry Cement: ASTM C91, Type S.
 - C. Premix Mortar: ASTM C387, Type S.
 - D. Mortar Aggregate: ASTM C144, standard masonry type.
 - E. Hydrated Lime: ASTM C207, Type S.
 - F. Water: Clean and potable.
 - G. Bonding Agent: Latex or Epoxy type.
- 2.02 MORTAR COLOR
- A. Mortar Color: Mineral oxide pigment; color to match adjacent CMU color, as selected by Architect.
- 2.03 MORTAR MIXES
- A. Mortar For Load Bearing Walls and Partitions: ASTM C270, Type M or S using the Property specification.
 - B. Mortar For Non-Load Bearing Walls and Partitions: ASTM C270, Type M or S using the Property specification.
 - C. Mortar For Engineered Masonry: ASTM C270, Type M or S using the Property specification.
 - D. Pointing Mortar: ASTM C270, Type N or O using the Property specification.
- 2.04 MORTAR MIXING
- A. Thoroughly mix mortar ingredients in accordance with ASTM C270 in quantities needed for immediate use.
 - B. Maintain sand uniformly damp immediately before the mixing process.
 - C. Add mortar color and admixtures in accordance with manufacturer's instructions. Provide uniformity of mix and coloration.
 - D. Do not use anti-freeze compounds to lower the freezing point of mortar.
 - E. If water is lost by evaporation, re-temper only within two hours of mixing.

- F. Use mortar within two hours after mixing at temperatures of 90 degrees F (32 degrees C), or two-and-one-half hours at temperatures under 40 degrees F.

2.05 GROUT MIXES

- A. Bond Beams, and Lintels: 3,000 psi strength at 28 days; 8-10 inches slump; premixed type in accordance with ASTM C94.
- B. Engineered Masonry: 3,000 psi strength at 28 days; 8-10 inches slump; premixed type in accordance with ASTM C94.

2.06 GROUT MIXING

- A. Mix grout in accordance with ASTM C94.
- B. Add admixtures in accordance with manufacturer's instructions; mix uniformly.
- C. Do not use anti-freeze compounds to lower the freezing point of grout.

PART 3 EXECUTION

3.01 EXAMINATION

- A. Request inspection of spaces to be grouted.

3.02 INSTALLATION

- A. Install mortar and grout in accordance with premix mortar manufacturer's instructions.
- B. Install mortar and grout in accordance with ASTM C270.
- C. Work grout into masonry cores and cavities to eliminate voids.
- D. Do not install grout in lifts greater than 16 inches or two CMU courses without consolidating grout by rodding.
- E. Do not displace reinforcement while placing grout.
- F. Remove excess mortar from grout spaces.

END OF SECTION 04100

SECTION 04300

UNIT MASONRY SYSTEM

PART 1 GENERAL

- 1.01 SECTION INCLUDES
 - A. Concrete masonry units.
 - B. Reinforcement, anchorage, and accessories.
- 1.02 SUBMITTALS
 - A. Submit under provisions of the General Requirements.
 - B. Product Data: Provide data for masonry and brick units and fabricated wire reinforcement.
- 1.03 QUALIFICATIONS
 - A. Manufacturer: Company specializing in manufacturing the Products specified in this section with minimum three years documented experience.
- 1.04 DELIVERY, STORAGE, AND HANDLING
 - A. Deliver, store, protect and handle products to site under provisions of the General Requirements.
 - B. Accept units on site. Inspect for damage.
- 1.05 ENVIRONMENTAL REQUIREMENTS
 - A. Maintain materials and surrounding air temperature to minimum 40 degrees F prior to, during, and 48 hours after completion of masonry work.
 - B. Maintain materials and surrounding air temperature to maximum 90 degrees F prior to, during, and 48 hours after completion of masonry work.
 - C. Hot Cold Weather Requirements: IMIAC - Recommended Practices and Guide Specifications for Hot or Cold Weather Masonry Construction.

PART 2 PRODUCTS

- 2.01 CONCRETE MASONRY UNITS
 - A. Non-Load Bearing Block Units (CMU): ASTM C90, Heavy weight, sand, light weight will not be accepted. Type I - Moisture Controlled.
 - B. Size and Shape: Nominal modular size of 8 and 4 x 16 x 8 inches. Provide special units for 90 degree corners.
 - C. Style and Color.
 - 1. Moisture controlled with coloring additive. Coloring to be determined by Architect.
 - 2. Provide as indicated on drawings:
- 2.02 REINFORCEMENT AND ANCHORAGE
 - A. Single Wythe Joint Reinforcement: Truss type; steel wire, hot dip galvanized to ASTM A641 after fabrication, No. 9 side rods with No. 9 cross ties.
 - 1. Manufacturers:
 - a. DUR-O-WALL
 - b. TRU-MESH
 - c. BET-R-WALL
 - B. Reinforcing Steel: ASTM A615, 40 or 60 ksi yield grade, deformed billet bars, uncoated finish.
 - C. Wall Ties: Formed steel wire, 3/16 inch thick, adjustable, hot dip galvanized to ASTM A123 steel finish.
 - 1. Manufacturers:
 - a. DUR-O-WALL
 - b. TRU-MESH
 - c. BET-R-WALL
- 2.03 MORTAR AND GROUT
 - A. Mortar and Grout: As specified in Section 04100.
- 2.04 FLASHINGS
 - A. Plastic Flashings: Sheet polyvinyl chloride or polyethylene; 20 mil thick.
 - B. Lap Sealant: Butyl type as specified in Section 07900.

2.05 ACCESSORIES

- A. Prefomed Control Joints: Rubber, Neoprene, Polyvinyl chloride material. Provide with corner and tee accessories, heat or cement fused joints.
- B. Joint Filler: Closed cell polyvinyl chloride, polyethylene, polyurethane or rubber; oversized 50 percent to joint width; self expanding.
- C. Building Paper: No. 30 asphalt saturated felt.
- D. Nailing Strips: Softwood, preservative treated for moisture resistance, dovetail shape, sized to masonry joints.
- E. Weeps: Prefomed plastic cotton wick filled, or cotton rope.
- F. Cavity Vents: Molded polyvinyl chloride grilles; insect resistant.
- G. Cleaning Solution: Non-acidic, not harmful to masonry work or adjacent materials.

PART 3 EXECUTION

3.01 EXAMINATION

- A. Verify that field conditions are acceptable and are ready to receive work.
- B. Verify items provided by other sections of work are properly sized and located.
- C. Verify that built-in items are in proper location, and ready for roughing into masonry work.

3.02 PREPARATION

- A. Direct and coordinate placement of metal anchors supplied to other sections.
- B. Provide temporary bracing during installation of masonry work. Maintain in place until building structure provides permanent bracing.

3.03 COURSING

- A. Establish lines, levels, and coursing indicated. Protect from displacement.
- B. Maintain masonry courses to uniform dimension. Form vertical and horizontal joints of uniform thickness.
- C. Concrete Masonry Units:
 - 1. Bond: Running unless otherwise indicated.
 - 2. Coursing: One unit and one mortar joint to equal 8 inches.
 - 3. Mortar Joints: Concave, unless noted otherwise.
- D. Brick Units:
 - 1. Bond: Running, unless noted otherwise.
 - 2. Coursing: Three units and three mortar joints to equal 8 inches.
 - 3. Mortar Joints: Concave, unless noted otherwise.

3.04 PLACING AND BONDING

- A. Lay solid masonry units in full bed of mortar, with full head joints, uniformly jointed with other work.
- B. Lay hollow masonry units with face shell bedding on head and bed joints.
- C. Buttering corners of joints or excessive furrowing of mortar joints are not permitted.
- D. Remove excess mortar as work progresses.
- E. Interlock intersections and external corners.
- F. Do not shift or tap masonry units after mortar has achieved initial set. Where adjustment must be made, remove mortar and replace.
- G. Perform job site cutting of masonry units with proper tools to provide straight, clean, unchipped edges. Prevent broken masonry unit corners or edges.
- H. Cut mortar joints flush where wall tile is scheduled, resilient base is scheduled, cavity insulation vapor barrier adhesive is applied, or bitumen dampproofing is applied.
- I. Isolate masonry partitions from vertical structural framing members with a control joint.
- J. Isolate top joint of masonry partitions from horizontal structural framing members and slabs or decks with compressible joint filler.

3.05 WEEPS

- A. Install weeps in veneer at 32 inches oc horizontally above through-wall flashing, above shelf angles and lintels, and at bottom of walls.

3.06 CAVITY WALL

- A. Do not permit mortar to drop or accumulate into cavity air space or to plug weeps.
- B. Build inner wythe ahead of outer wythe to receive cavity insulation and air/vapor barrier adhesive.

- 3.07 REINFORCEMENT AND ANCHORAGE
- A. Install horizontal joint reinforcement 16 inches oc.
 - B. Place masonry joint reinforcement in first and second horizontal joints above and below openings. Extend minimum 16 inches each side of opening.
 - C. Place joint reinforcement continuous in first and second joint below top of walls.
 - D. Lap joint reinforcement ends minimum 6 inches.
 - E. Support and secure reinforcing bars from displacement. Maintain position within 1/2 inch of dimensioned position.
 - F. At masonry veneer, embed wall ties in masonry back-up to bond veneer at maximum 16 inches oc vertically and 36 inches oc horizontally. Place at maximum 3 inches oc each way around perimeter of openings, within 12 inches of openings.
- 3.08 MASONRY FLASHINGS
- A. Extend flashings horizontally at foundation walls, above ledge or shelf angles and lintels, under parapet caps, and at bottom of walls.
 - B. Turn flashing up minimum 8 inches and bed into mortar joint of masonry, seal to concrete, seal or underlap at sheathing over framed back-up.
 - C. Lap end joints minimum 6 inches and seal watertight.
 - D. Turn flashing, fold, and seal at corners, bends, and interruptions.
- 3.09 GROUTED COMPONENTS
- A. Reinforce bond beam as indicated or detailed.
 - B. Lap splices minimum 24 bar diameters.
 - C. Support and secure reinforcing bars from displacement. Maintain position within 1/2 inch of dimensioned position.
 - D. Place and consolidate grout fill without displacing reinforcing.
 - E. At bearing locations, fill masonry cores with grout for a minimum 12 inches either side of opening.
- 3.10 CONTROL AND EXPANSION JOINTS
- A. Do not continue horizontal joint reinforcement through control and expansion joints.
 - B. Install preformed control joint device in continuous lengths. Seal butt and corner joints in accordance with manufacturer's instructions.
 - C. Size control joint in accordance with Section 07900 for sealant performance.
 - D. Form expansion joint as detailed.
- 3.11 BUILT-IN WORK
- A. As work progresses, install built-in metal door and glazed frames, fabricated metal frames, window frames, wood nailing strips, fireplace accessories, anchor bolts, plates, and other items to be built-in the work and furnished by other sections.
 - B. Install built-in items plumb and level.
 - C. Bed anchors of metal door and glazed frames in adjacent mortar joints. Fill frame voids solid with grout. Fill adjacent masonry cores with grout minimum 12 inches from framed openings.
 - D. Do not build in organic materials subject to deterioration.
- 3.12 TOLERANCES
- A. Maximum Variation From Alignment of Columns: 1/4 inch.
 - B. Maximum Variation From Unit to Adjacent Unit: 1/32 inch.
 - C. Maximum Variation from Plane of Wall: 1/4 inch in 10 ft and 1/2 inch in 20 ft or more.
 - D. Maximum Variation from Plumb: 1/4 inch per story non-cumulative; 1/2 inch in two stories or more.
 - E. Maximum Variation from Level Coursing: 1/8 inch in 3 ft and 1/4 inch in 10 ft; 1/2 inch in 30 ft.
 - F. Maximum Variation of Joint Thickness: 1/8 inch in 3 ft.
 - G. Maximum Variation from Cross Sectional Thickness of Walls: 1/4 inch.
- 3.13 CUTTING AND FITTING
- A. Cut and fit for chases, pipes, conduit, sleeves, and grounds. Coordinate with other sections of work to provide correct size, shape, and location.
 - B. Obtain approval prior to cutting or fitting masonry work not indicated or where appearance or strength of masonry work may be impaired.
- 3.14 CLEANING
- A. Remove excess mortar and mortar smears as work progresses.
 - B. Replace defective mortar. Match adjacent work.

- C. Clean soiled surfaces with cleaning solution.
 - D. Use non-metallic tools in cleaning operations.
- 3.15 PROTECTION OF FINISHED WORK
- A. Protect finished Work.
 - B. Without damaging completed work, provide protective boards at exposed external corners which may be damaged by construction activities.

END OF SECTION 04300

SECTION 04700

MANUFACTURED MASONRY

PART 1 - GENERAL

1.01 SUMMARY

- A. Section Includes: Manufactured stone veneer, Manufactured stone trim, and application materials, as indicated on the drawings.
- B. Building Materials Evaluation Commission.
- C. International Code Council (ICC):
 - 1. ES Report., UBC Standard No. 14-1, Kraft Waterproof Building Paper.
- D. Masonry Standards Joint Committee (MSJC) of The Masonry Society.
- E. Underwriters Laboratories (UL): Listing in Material Approval Guide. UL 723, Standard for Safety for Surface Burning Characteristics of Building Materials.

1.02 SUBMITTALS

- A. Reference Section 01 33 00–Submittal Procedures; submit following items:
 - 1. Product Data: Manufactured masonry and application materials **including mortar color charts & samples, and weather resistant barrier.**
 - 2. Samples: Panel/Sample board containing full-size samples of specified manufactured masonry showing full range of colors and textures **complete with specified mortar.**
 - a. Actual size of masonry sample approximately 12 by 12 inches (300 by 300 mm).
 - 3. Quality Assurance/Control Submittals:
 - a. Qualifications: Proof of manufacturer qualifications, Proof of installer qualifications, Certificates: ICC-ES Repor, Manufacturer’s Installation Instructions.

1.03 QUALITY ASSURANCE

- A. Qualifications:
 - 1. Manufacturer Qualifications: Minimum five years experience in producing manufactured masonry.
 - 2. Installer Qualifications: Company with documented experience in installation of manufactured masonry including minimum 5 projects within 500 mile radius of this Project.

1.04 DELIVERY, STORAGE, AND HANDLING

- A. Reference Section 01 66 00–Product Storage and Handling Requirements.
- B. Follow manufacturer’s instructions.
- C. Store moisture-sensitive materials in weather protected enclosures.

1.05 PROJECT/SITE CONDITIONS

- A. Environmental Requirements: Maintain materials and ambient temperature in area of installation at minimum 40 degrees F (4 degrees C) prior to, during, and for 48 hours following installation.

1.06 WARRANTY

- A. Special Warranty: Provide manufacturer's standard limited warranty against defects in manufacturing for a period of 50 years following date of Final Acceptance.

1.07 MAINTENANCE

- A. Extra Materials: Furnish extra manufactured stone material in a variety of shapes and sizes in quantity equal to three percent of the installed stone.

PART 2 - PRODUCTS

2.01 MANUFACTURER

- A. **Stone Veneer 1: StoneWorks, Grezzo, Color: San Domino Grezzo, Medio Design**
 - 1. Thickness 1.5” – 2.5” min.
 - 2. Size: 5”x14”
 - 3. Installation pattern: Subway (brick lay)
 - 4. Location – as indicated on drawings as “Stone Veneer 1”.
- B. Substitutions: As approved equal prior to bidding.

2.02 MANUFACTURED MASONRY MATERIALS

- A. As selected by Owner or to Match Existing at additional Phases.

2.03 RELATED MATERIALS

- A. Weather Resistant Barrier: [Kraft waterproof building paper, UBC Standard No. 14-1] [No. 15, Type I, asphalt saturated felt, ASTM D 226].
- B. Metal Lath: [2.5 lb (1.4 kg/m²) galvanized expanded metal lath] [18 (1.3 mm) gauge woven wire mesh] [3.4 lb (1.8 kg/m²) galvanized expanded rib lath].
- C. Fasteners:
1. Into Wood Studs: Minimum 0.120 inch (3 mm) shank diameter galvanized nails or staples of sufficient length to penetrate 1-3/8 inches (35 mm) minimum into the stud.
 2. Into Metal Studs: Minimum 7/16 inch (11.1 mm) head diameter, corrosion-resistant, self-drilling, self tapping, pancake head screws of sufficient length to penetrate 3/8 inch (10 mm) minimum into the stud.
- D. Mortar: Premixed Type N or mortar mixed using components and proportions following manufactured masonry manufacturer's installation instructions. Comply with ASTM C 270.
1. Mortar Color: Iron oxide pigments.

PART 3 - EXECUTION

3.01 EXAMINATION

- A. Examine substrates upon which manufactured masonry will be installed.
- B. Coordinate with responsible entity to correct unsatisfactory conditions.
- C. Commencement of work by installer is acceptance of substrate conditions.

3.02 PREPARATION

- A. Protection: Prevent work from occurring on the opposite of walls to which manufactured masonry is applied during and for 48 hours following installation of the manufactured masonry.
- B. Surface Preparation: Follow manufacturer's instructions designated below for the appropriate type of manufactured masonry and substrate.

3.03 INSTALLATION

- A. Per the manufacturers recommendations provide lath and scratch coat of 1/2" min. thickness, with 1/4" min. set coat. Total min. thickness including masonry unit of 2"- 2.5".
- B. Install Cultured Stone[®] products in accordance with manufacturer's Cultured Stone[®] installation instructions using grouted joints.
- C. Install Cultured Brick[®] products in accordance with manufacturer's Cultured Brick[®] installation instructions.
- D. Install architectural trim products in accordance with manufacturer's Cultured Stone[®] installation instructions.
- E. Install/Apply Related Materials specified above in accordance with type of substrate and manufactured masonry manufacturer's installation instructions.

3.04 FIELD QUALITY CONTROL

3.05 CLEANING

- A. Clean manufactured masonry in accordance with manufacturer's installation instructions.

3.06 PROTECTION

- A. Protect finished work from rain during and for 48 hours following installation.
- B. Protect finished work from damage during remainder of construction period.

END OF SECTION 04700

SECTION 04720

CAST STONE

PART 1 - GENERAL

1.01 RELATED DOCUMENTS

- A. Drawings and general provisions of the Contract, including General and Supplementary Conditions and Division 1 Specification Sections, apply to this Section.

1.02 SUMMARY

- A. This Section includes the following:
 - 1. Cast Stone, including the following:
 - a. Caps and Sills
 - b. Window Sills & Headers
 - c. Accent Bands
 - d. Corner Accent Quoins

1.04 SUBMITTALS

- A. Product Data: Include construction details, material descriptions, dimensions of individual components and profiles, and finishes for cast stone units.
- B. Samples for Initial Selection: For colored mortar.

1.06 DELIVERY, STORAGE, AND HANDLING

- A. Coordinate delivery of cast stone with unit masonry work to minimize the need for on-site storage and to avoid delaying the Work.
- B. Pack, handle, and ship cast stone units in suitable packs or pallets.
 - 1. Lift with wide-belt slings; do not use wire rope or ropes that might cause staining. Move cast stone units, if required, using dollies with wood supports.
 - 2. Store cast stone units on wood skids or pallets with non-staining, waterproof covers. Arrange to distribute weight evenly and to prevent damage to units. Ventilate under covers to prevent condensation.
- C. Store installation materials on elevated platforms, under cover, and in a dry location.
- D. Store mortar aggregates where grading and other required characteristics can be maintained and contamination can be avoided.

1.07 PROJECT CONDITIONS

- A. Cold-Weather Requirements: Do not use frozen materials or materials mixed or coated with ice or frost. Do not build on frozen substrates. Comply with cold-weather construction requirements contained in ACI 530.1/ASCE 6/TMS 602.
 - 3. Cold-Weather Cleaning: Use liquid cleaning methods only when air temperature is 40 deg F (4 deg C) and above and will remain so until cast stone has dried, but not less than 7 days after completing cleaning.
- B. Hot-Weather Requirements: Comply with hot-weather construction requirements contained in ACI 530.1/ASCE 6/TMS 602.

PART 2 - PRODUCTS

2.01 MANUFACTURERS

- A. Superior Pre-Cast Products Inc. (269) 344-7690.
- B. Architectural Cast Stone (316) 262-5543.
- C. Kelley Cast Stone (316) 943-6690
- D. Substitutions: Under the provisions of the General Requirements.

2.02 CAST STONE MATERIALS

- A. Caps and Sills: Smooth cut and finish, color to be selected. Size and shape per drawings.
- B. Window Sills, Headers and Accent Bands: Smooth cut and finish, color to be selected. Size and shape per drawings.
- C. Corner Accent Quoins: Smooth cut and finish, color to be selected. Size and shape per drawings.
- D. Fabrication Tolerances:
 - 1. Variation Cross Section: Do not vary from indicated dimensions more than 1/8 inch (3 mm).
 - 2. Variation Length: Do not vary from indicated dimensions by more than 1/360 of the length of unit or 1/8 inch (3 mm), whichever is greater, but in no case by more than 1/4 inch (6 mm).
 - 3. Warp, Bow, and Twist: Not to exceed 1/360 of the length of unit or 1/8 inch (3 mm), whichever is greater.
- E. Color(s): 2 Colors will be used: To be selected by Architect.

2.04 MORTAR MATERIALS

- A. Provide mortar materials that comply with Division 4 Section "Unit Masonry Assemblies."
- B. Portland Cement: ASTM C 150, Type I or II, except Type III may be used for cold-weather construction. Provide natural color or white cement as required to produce mortar color indicated.
- C. Hydrated Lime: ASTM C 207, Type S.
- D. Portland Cement-Lime Mix: Packaged blend of portland cement complying with ASTM C 150, Type I or Type III, and hydrated lime complying with ASTM C 207, Type S.
- E. Mortar Cement: ASTM C 1329.
- F. Mortar Pigments: Natural and synthetic iron oxides and chromium oxides, compounded for use in mortar mixes. Use only pigments with a record of satisfactory performance in masonry mortar.
- G. Colored Cement Product: Packaged blend made from portland cement and lime masonry cement or mortar cement and mortar pigments, all complying with specified requirements and containing no other ingredients.
 - 1. Formulate blend as required to produce color indicated or, if not indicated, as selected from manufacturer's standard colors.
 - 2. Pigments shall not exceed 10 percent of portland cement by weight.
 - 3. Pigments shall not exceed 5 percent of masonry cement or mortar cement by weight.
- H. Aggregate for Mortar: ASTM C 144.
 - 4. For mortar that is exposed to view, use washed aggregate consisting of natural sand or crushed stone.
 - 5. For joints less than 1/4 inch (6 mm) thick, use aggregate graded with 100 percent passing the No. 16 (1.18-mm) sieve.
 - 6. White-Mortar Aggregates: Natural white sand or crushed white stone.
 - 7. Colored-Mortar Aggregates: Natural sand or crushed stone of color necessary to produce required mortar color.
- I. Water: Potable.

2.05 ACCESSORIES

- A. Anchors: Type and size indicated, fabricated from stainless steel complying with ASTM A 240/A 240M, ASTM A 276, or ASTM A 666, Type 304.
- B. Anchors: Type and size indicated, fabricated from steel complying with ASTM A 36/A 36M, and hot-dip galvanized to comply with ASTM A 123/A 123M.
- C. Dowels: Round stainless-steel bars complying with ASTM A 276, Type 304, and 1/2-inch (12-mm) diameter.
- D. Dowels: Round steel bars complying with ASTM A 36/A 36M or ASTM A 615/A 615M, 1/2-inch (12-mm) diameter, and hot-dip galvanized to comply with ASTM A 123/A 123M.
- E. Proprietary Acidic Cleaner: Manufacturer's standard-strength, general-purpose cleaner designed for removing mortar/grout stains, efflorescence, and other construction stains from new masonry surfaces without discoloring or damaging masonry surfaces; expressly approved for intended use by cast stone manufacturer and expressly approved by cleaner manufacturer for use on cast stone and adjacent masonry materials.

2.06 MORTAR MIXES

- A. Comply with requirements in Division 4 Section "Unit Masonry Assemblies" for mortar mixes.
- B. Do not use admixtures, including pigments, air-entraining agents, accelerators, retarders, water-repellent agents, antifreeze compounds, or other admixtures, unless otherwise indicated.

1. Do not use calcium chloride in mortar.
2. Limit cementitious materials in mortar to portland cement, mortar cement, and lime.
- C. Comply with ASTM C 270, Proportion Specification.
 1. For setting mortar, use Type S.
 2. For pointing mortar, use Type N.
- D. Pigmented Mortar: Use colored cement product or select and proportion pigments with other ingredients to produce color required. Do not add pigments to colored cement products.
 1. Pigments shall not exceed 10 percent of portland cement by weight.
 2. Pigments shall not exceed 5 percent of masonry cement or mortar cement by weight.
- E. Colored-Aggregate Mortar: Produce required mortar color by using colored aggregates and natural color or white cement as necessary to produce required mortar color.
 1. Mix to match Architect's sample.

2.07 SOURCE QUALITY CONTROL

- A. Employ an independent testing agency to sample and test cast stone units according to ASTM C 1364.
 1. Include one test for resistance to freezing and thawing.

PART 3 - EXECUTION

3.01 EXAMINATION

- A. Examine substrates and conditions, with Installer present, for compliance with requirements for installation tolerances and other conditions affecting performance of cast stone.
 1. Proceed with installation only after unsatisfactory conditions have been corrected.

3.02 SETTING CAST STONE IN MORTAR

- B. Install cast stone units to comply with requirements in Division 4 Section "Unit Masonry Assemblies."
- C. Set cast stone as indicated on Drawings. Set units accurately in locations indicated with edges and faces aligned according to established relationships and indicated tolerances.
 1. Install anchors, supports, fasteners, and other attachments indicated or necessary to secure units in place.
 2. Install masonry blocks as required to space and slope units as detailed.
 3. Install mortar net and weeps per the drawings and as recommended by Manufacturer.
- D. Wet joint surfaces thoroughly before applying mortar or setting in mortar.
- E. Set units in full bed of mortar with full head joints, unless otherwise indicated.
 1. If not indicated, set units with joints 3/8 to 1/2 inch (10 to 13 mm) wide.
 2. Build anchors and ties into mortar joints as units are set.
 3. Fill dowel holes and anchor slots with mortar.
 4. Fill collar joints solid as units are set.
 5. Build concealed flashing into mortar joints as units are set.
 6. Keep head joints in coping and other units with exposed horizontal surfaces open to receive sealant.
 7. Keep joints at shelf angles open to receive sealant.
- F. Rake out joints for pointing with mortar to depths of not less than 3/4 inch (19 mm). Rake joints to uniform depths with square bottoms and clean sides. Scrub faces of units to remove excess mortar as joints are raked.
- G. Point mortar joints by placing and compacting mortar in layers not greater than 3/8 inch (10 mm). Compact each layer thoroughly and allow it to become thumbprint hard before applying next layer.
- H. Tool exposed joints slightly concave when thumbprint hard, using a jointer larger than joint thickness, unless otherwise indicated.
- I. Provide expansion, control, and pressure-relieving joints of widths and at locations indicated. Keep joints free of mortar and other rigid materials.
 1. Form open joint of width indicated, but not less than 1/2 inch (13 mm).
- J. Prepare joints indicated to receive sealant and apply sealant of type and at locations indicated to comply with applicable requirements in Division 7 Section "Joint Sealants."
 1. Prime cast stone surfaces to receive sealant and install compressible backer rod in joints before applying sealant, unless otherwise indicated.

3.04 INSTALLATION TOLERANCES

- A. Variation from Plumb: Do not exceed 1/8 inch in 10 feet (3 mm in 3 m), 1/4 inch in 20 feet (6 mm in 6 m), or 1/2 inch (12 mm) maximum.
- B. Variation from Level: Do not exceed 1/8 inch in 10 feet (3 mm in 3 m), 1/4 inch in 20 feet (6 mm in 6 m), or 1/2 inch (12 mm) maximum.
- C. Variation in Joint Width: Do not vary joint thickness more than 1/8 inch in 36 inches (3 mm in 900 mm) or one-fourth of nominal joint width, whichever is less.
- D. Variation in Plane between Adjacent Surfaces (Lipping): Do not vary from flush alignment with adjacent units or adjacent surfaces indicated to be flush with units by more than 1/16 inch (1.5 mm), except due to warpage of units within tolerances specified.

3.05 ADJUSTING AND CLEANING

- A. Remove and replace stained and otherwise damaged units and units not matching approved Samples. Cast stone may be repaired if methods and results are approved by Architect.
- B. Replace units in a manner that results in cast stone matching approved Samples, complying with other requirements, and showing no evidence of replacement.
- C. In-Progress Cleaning: Clean cast stone as work progresses.
 - 1. Remove mortar fins and smears before tooling joints.
 - 2. Remove excess sealant immediately, including spills, smears, and spatter.
- D. Final Cleaning: After mortar is thoroughly set and cured, clean exposed cast stone as follows:
 - 1. Remove large mortar particles by hand with wooden paddles and nonmetallic scrape hoes or chisels.
 - 2. Test cleaning methods on sample; leave one sample uncleaned for comparison purposes. Obtain Architect's approval of sample cleaning before proceeding with cleaning of cast stone.
 - 3. Protect adjacent surfaces from contact with cleaner by covering them with liquid strippable masking agent or polyethylene film and waterproof masking tape.
 - 4. Wet surfaces with water before applying cleaners; remove cleaners promptly by rinsing thoroughly with clear water.
 - 5. Clean cast stone by bucket-and-brush hand-cleaning method described in BIA Technical Notes No. 20.
 - 6. Clean cast stone with proprietary acidic cleaner applied according to manufacturer's written instructions.

END OF SECTION 04720

SECTION 05120

STRUCTURAL STEEL

PART 1 GENERAL

1.01 SECTION INCLUDES

- A. Structural steel framing members and support members.
- B. Base plates.
- C. Grouting under base plates.

1.02 GENERAL

- A. All notes or specifications on structural drawings shall override any discrepancies listed.

1.03 SUBMITTALS

- A. Submit under provisions of the General Requirements.
- B. Shop Drawings:
 - 1. Indicate profiles, sizes, spacing, and locations of structural members, openings, attachments, and fasteners.
 - 2. Connections and Connections not detailed.
 - 3. Cambers, and loads.
 - 4. Indicate welded connections with AWS A2.0 welding symbols. Indicate net weld lengths.
- C. Welders Certificates: Certify welders employed on the Work, verifying AWS qualification within the previous 12 months.

1.04 QUALITY ASSURANCE

- A. Fabricate structural steel members in accordance with AISC - Specification for the Design, Fabrication and Erection of Structural Steel for Buildings.
- B. Perform Work in accordance with AISC - Specification for Architectural Exposed Structural Steel.

1.05 QUALIFICATIONS

- A. Fabricator: Company specializing in performing the work of this Section with minimum 5 years' documented experience.
- B. Erector: Company specializing in performing the work of this Section with minimum 5 years' documented experience.
- C. Design connections not detailed on the Drawings under direct supervision of a Professional Structural Engineer experienced in design of this work and licensed in the State of Kansas.

1.06 FIELD MEASUREMENTS

- A. Verify that field measurements are as shown on shop drawings and/or as instructed by the manufacturer.

1.07 MISCELLANEOUS ITEMS

- A. All miscellaneous items required to complete the work in accordance with the intent of the Drawings and Specifications, shall be furnished and installed, regardless of whether or not specifically shown or described. Such items include masonry anchors, dovetail slots, dowels and cramps, loose or embedded items of structural shapes, plates, bars, shield, and other fastening devices which may or may not be provided with the indicated or specified items shall also be furnished and installed as required for attachment and support.

PART 2 PRODUCTS

2.01 MATERIALS

- A. Reference drawings and notes on the drawings.

2.02 FINISH

- A. Prepare structural component surfaces in accordance with SSPC SP 2.
- B. Shop prime structural steel members. Do not prime surfaces that will be fireproofed, field welded, in contact with concrete or high strength bolts.

PART 3 EXECUTION

3.01 EXAMINATION

- A. Verify that field conditions are acceptable and are ready to receive work.

3.02 ERECTION

- A. Allow for erection loads, and for sufficient temporary bracing to maintain structure safe, plumb, and in true alignment until completion of erection and installation of permanent bracing.
- B. Field weld components and shear studs indicated on Drawings and/or shop drawings.
- C. Do not field cut or alter structural members without approval of Architect/Engineer.
- D. After erection, prime welds, abrasions, and surfaces not shop primed or galvanized, except surfaces to be in contact with concrete.
- E. Grout under base plates as indicated.

3.03 ERECTION TOLERANCES

- A. Maximum Variation From Plumb: 1/4 inch per story, non-cumulative.
- B. Maximum Offset From True Alignment: 1/4 inch.

END OF SECTION 05120

SECTION 05520

HANDRAILS AND RAILINGS

PART 1 GENERAL

1.01 SECTION INCLUDES

- A. Steel pipe, tube handrails, balusters, and fittings.

1.02 DESIGN REQUIREMENTS

- A. Railing assembly, wall rails, and attachments to resist lateral force of 75 lbs. at any point without damage or permanent set.

1.03 SUBMITTALS

- A. Shop Drawings: Indicate profiles, sizes, connection attachments, anchorage, size, and type of fasteners, and accessories.

1.04 FIELD MEASUREMENTS

- A. Verify that field measurements are as indicated on shop drawings.

PART 2 PRODUCTS

2.01 STEEL RAILING SYSTEM

- A. Rails and Posts: As detailed and indicated on the drawings.
- B. Fittings: Elbows, T-shapes, wall brackets, escutcheons; machined steel.
- C. Mounting: Adjustable brackets and flanges, with steel inserts for casting in concrete and/or steel brackets for embedding in masonry. Prepare backing plate for mounting in wall construction.
- D. Exposed Fasteners: Flush countersunk screws or bolts; consistent with design of railing.
- E. Splice Connectors: Steel concealed spigots, welding collars.

2.02 FABRICATION

- A. Fit and shop assemble components in largest practical sizes, for delivery to site.
- B. Fabricate components with joints tightly fitted and secured.
- C. Exposed Mechanical Fastenings: Flush countersunk screws or bolts; unobtrusively located; consistent with design of component, except where specifically noted otherwise.
- D. Supply components required for anchorage of fabrications. Fabricate anchors and related components of same material and finish as fabrication, except where specifically noted otherwise.
- E. Continuously seal joined pieces by continuous welds.
- F. Grind exposed joints flush and smooth with adjacent finish surface. Make exposed joints butt tight, flush, and hairline. Ease exposed edges to small uniform radius.
- G. Accurately form components to suit stairs and landings, to each other and to building structure.

PART 3 EXECUTION

3.01 EXAMINATION

- A. Verify that field conditions are acceptable and are ready to receive work.
- B. Beginning of installation means erector accepts existing conditions.

3.02 PREPARATION

- A. Clean and strip primed steel items to bare metal where site welding is required.
- B. Supply items required to be cast into concrete and/or embedded in masonry, placed in partitions with setting templates, to appropriate Sections.

3.03 INSTALLATION

- A. Install in accordance with manufacturer's instructions.
- B. Install components plumb and level, accurately fitted, free from distortion or defects.
- C. Provide anchors, plates angles required for connecting railings to structure. Anchor railing to structure.
- D. Field weld anchors as indicated on Drawings. Touch-up welds with primer. Grind welds smooth.

- E. Conceal bolts and screws whenever possible. Where not concealed, use flush countersunk fastenings.

3.04 ERECTION TOLERANCES

- A. Maximum Variation From Plumb: 1/4 inch per story, non-cumulative.
- B. Maximum Offset From True Alignment: 1/4 inch.

END OF SECTION 05520

SECTION 06100

ROUGH CARPENTRY

PART 1 - GENERAL

1.1 RELATED DOCUMENTS

- A. Drawings and general provisions of the Contract, including General and Supplementary Conditions and Division 1 Specification Sections, apply to this Section.

1.2 SUMMARY

- A. This Section includes the following:
 1. Framing with dimension lumber.
 2. Framing with timber.
 3. Framing with engineered wood products.
 4. Wood blocking, canta, and nailers.
 5. Utility shelving.
 6. Wood furring.
 7. Sheathing.
 8. Subflooring and underlayment.
 9. Plywood backing panels.
 10. Building wrap.

1.3 QUALITY ASSURANCE

- A. Testing Agency Qualifications: An independent testing agency, acceptable to authorities having jurisdiction, with the experience and capability to conduct the testing indicated, as documented according to ASTM E 548.
- B. Source Limitations for Engineered Wood Products: Obtain each type of engineered wood product through one source from a single manufacturer.
- C. Source Limitations for Fire-Retardant-Treated Wood: Obtain each type of fire-retardant-treated wood product through one source from a single producer.

1.4 DELIVERY, STORAGE, AND HANDLING

- A. Stack lumber, plywood, and other panels; place spacers between each bundle to provide air circulation. Provide for air circulation around stacks and under coverings.

PART 2 - PRODUCTS

2.1 WOOD PRODUCTS, GENERAL

- A. Lumber: DOC PS 20 and applicable rules of lumber grading agencies certified by the American Lumber Standards Committee Board of Review.
 1. Factory mark each piece of lumber with grade stamp of grading agency.
 2. For exposed lumber indicated to receive a stained or natural finish, mark grade stamp on end or back of each piece.
 3. Where nominal sizes are indicated, provide actual sizes required by DOC PS 20 for moisture content specified. Where actual sizes are indicated, they are minimum dressed sizes for dry lumber.
 4. Provide dressed lumber, S4S, unless otherwise indicated.
 5. Provide dry lumber with 19 percent maximum moisture content at time of dressing for 2-inch nominal thickness or less, unless otherwise indicated.
 6. Provide dry lumber with 15 percent maximum moisture content at time of dressing for 2-inch nominal thickness or less, unless otherwise indicated.

- B. Engineered Wood Products: Provide engineered wood products acceptable to authorities having jurisdiction and for which current model code research or evaluation reports exist that show compliance with building code in effect for Project.
 - 1. Allowable Design Stresses: Provide engineered wood products with allowable design stresses, as published by manufacturer that meet or exceed those indicated. Manufacturer's published values shall be determined from empirical data or by rational engineering analysis and demonstrated by comprehensive testing performed by a qualified independent testing agency.

C. Wood Structural Panels:

- 1. Plywood: DOC PS 1.
- 2. Oriented Strand Board: DOC PS 2.
- 3. Thickness: As needed to comply with requirements specified but not less than thickness indicated.
- 4. Comply with "Code Plus" provisions in APA Form No. E30K, "APA Design/Construction Guide: Residential & Commercial."
- 5. Factory mark panels according to indicated standard.

2.2 WOOD-PRESERVATIVE-TREATED MATERIALS

- A. Preservative Treatment by Pressure Process: AWWA C2 lumber except that lumber that is not in contact with the ground and is continuously protected from liquid water may be treated according to AWWA C31 with inorganic boron (SBX).

- 1. Preservative Chemicals: Acceptable to authorities having jurisdiction and one of the following:
 - a. Chromated copper arsenate (CCA).
 - b. Ammoniacal copper zinc arsenate (ACZA).
 - c. Ammoniacal, or amine, copper quat (ACQ).
 - d. Copper bis (dimethyldithiocarbamate) (CDDC).
 - e. Ammoniacal copper citrate (CC).
 - f. Copper azole, Type A (CBA-A).
 - g. Oxine copper (copper-8-quinolinolate) in a light petroleum solvent.
- 2. For exposed items indicated to receive a stained or natural finish, use chemical formulations that do not require incising, contain colorants, bleed through, or otherwise adversely affect finishes.

- B. Kiln-dry material after treatment to a maximum moisture content of 19 percent for lumber and 15 percent for plywood. Do not use material that is warped or does not comply with requirements for untreated material.

- C. Mark each treated item with the treatment quality mark of an inspection agency approved by the American Lumber Standards Committee Board of Review.

- D. Application: Treat items indicated on Drawings, and the following:

- 1. Wood cants, nailers, curbs, equipment support bases, blocking, stripping, and similar members in connection with roofing, flashing, vapor barriers, and waterproofing.
- 2. Wood sills, sleepers, blocking, furring, stripping, and similar concealed members in contact with masonry or concrete.
- 3. Wood framing members less than 18 inches above grade.
- 4. Wood floor plates that are installed over concrete slabs directly in contact with earth.

2.3 FIRE-RETARDANT-TREATED MATERIALS

- A. General: Where fire-retardant-treated materials are indicated, provide materials that comply with performance requirements in AWWA C20 lumber and AWWA C27 plywood. Identify fire-retardant-treated wood with appropriate classification marking of UL, U.S. Testing, Timber Products Inspection, or another testing and inspecting agency acceptable to authorities having jurisdiction.

1. Use treatment for which chemical manufacturer publishes physical properties of treated wood after exposure to elevated temperatures, when tested by a qualified independent testing agency according to ASTM D 5664, for lumber and ASTM D 5516, for plywood
 2. Use treatment that does not promote corrosion of metal fasteners.
 3. Use Exterior type for exterior locations and where indicated.
 4. Use Interior Type A High Temperature (HT), unless otherwise indicated.
- B. For exposed items indicated to receive a stained or natural finish, use chemical formulations that do not bleed through, contain colorants, or otherwise adversely affect finishes.

2.4 DIMENSION LUMBER

- A. General: Provide dimension lumber of grades indicated according to the American Lumber Standards Committee National Grading Rule provisions of the grading agency indicated.
- B. Non-Load-Bearing Interior Partitions: Construction, Stud, or No. 2 grade.
- C. Exterior and Load-Bearing Walls Construction or No. 2 grade.
- D. Ceiling Joists (Non-Load-Bearing): Construction or No. 2 grade.
- E. Joists, Rafters, and Other Framing Not Listed Above: Construction or No. 1 grade.

2.5 MISCELLANEOUS LUMBER

- A. General: Provide lumber for support or attachment of other construction, including the following:
 1. Rooftop equipment bases and support curbs.
 2. Blocking.
 3. Cants.
 4. Nailers.
 5. Furring.
 6. Grounds.
- B. For items of dimension lumber size, provide Construction, Stud, or No. 2 grade lumber with 15 percent maximum moisture content.
- C. For exposed boards, provide lumber with 15 percent maximum moisture content.
- D. For concealed boards, provide lumber with 15 percent maximum moisture content.
- E. For furring strips for installing plywood or hardboard paneling, select boards with no knots capable of producing bent-over nails and damage to paneling.

2.6 ENGINEERED WOOD PRODUCTS

- A. Veneer Lumber: A composite of wood veneers with grain primarily parallel to member lengths, manufactured with an exterior-type adhesive complying with ASTM D 2559.
 1. Extreme Fiber Stress in Bending, Edgewise: 2600 psi minimum
 2. Modulus of elasticity, Edgewise: 2,000,000 psi minimum
 3. Horizontal Shear: 285 psi
 4. Tension Parallel to Grain: 1500 psi minimum
- B. Parallel-Strand Lumber: A composite of wood strand elements with grain primarily parallel to member lengths, manufactured with an exterior-type adhesive complying with ASTM D 2559.
- C. Wood I-Joists: Prefabricated units complying with APA PRI-400; depths and performance ratings not less than those indicated.
- D. Rim Boards: Performance-rated product complying with APA PRR-401.

2.7 SHEATHING

- A. Reference drawings, the following are minimums where sheathing is not noted on drawings.
- B. Plywood Wall Sheathing: Exposure 1, Structural I sheathing.
 1. Span Rating: Not less than 24/0.
 2. Thickness: Not less than 1/2 inch.

- C. Oriented-Strand-Board Wall Sheathing: Exposure 1, Structural I sheathing.
 - 1. Span Rating: Not less than 24/0.
 - 2. Thickness: Not less than 1/2 inch.
 - D. Glass-Mat Gypsum Wall Sheathing: ASTM C 1177/1177M.
 - 1. Product: Subject to compliance with requirements, provide "Dens-Glass Gold" by G-P Gypsum Corp.
 - 2. Type and Thickness: Regular, 5/8 inch thick.
 - 3. Size: 48 by 96 inches for vertical installation.
 - E. Plywood Roof Sheathing: Exterior, Structural I sheathing.
 - 1. Span Rating: Not less than 32/16.
 - 2. Thickness: Not less than 1/2 inch.
 - F. Oriented-Strand-Board Roof Sheathing: Exposure 1, Structural I sheathing.
 - 1. Span Rating: Not less than 32/16.
 - 2. Thickness: Not less than 5/8 inch.
- 2.8 PLYWOOD BACKING PANELS
- A. Telephone and Electrical Equipment Backing Panels: DOC PS 1, Exposure 1, C-D Plugged, fire-retardant treated, in thickness indicated or, if not indicated, not less than 1/2 inch thick.
- 2.9 FASTENERS
- A. General: Provide fasteners of size and type indicated that comply with requirements specified in this Article for material and manufacture.
 - 1. Where rough carpentry is exposed to weather, in ground contact, or in area of high relative humidity, provide fasteners with hot-dip zinc coating complying with ASTM A 153/A 153M.
 - B. Nails, Brads, and Staples: ASTM F 1667.
 - C. Power-Driven Fasteners: CABO NER-272.
 - D. Wood Screws: ASME B18.6.1.
 - E. Screws for Fastening to Cold-Formed Metal Framing: ASTM C 954, except with wafer heads and reamer wings, length as recommended by screw manufacturer for material being fastened.
 - F. Lag Bolts: ASME B18.2.1.
 - G. Bolts: Steel bolts complying with ASTM A 307, Grade A with ASTM A 563 hex nuts and, where indicated, flat washers.
 - H. Expansion Anchors: Anchor bolt and sleeve assembly of material indicated below with capability to sustain, without failure, a load equal to 6 times the load imposed when installed in unit masonry assemblies and equal to 4 times the load imposed when installed in concrete as determined by testing per ASTM E 488 conducted by a qualified independent testing and inspecting agency.
 - 1. Material: Carbon-steel components, zinc plated to comply with ASTM B 633, Class Fe/Zn 5.
 - 2. Material: Stainless steel with bolts and nuts complying with ASTM F 593 and ASTM F 594, Alloy Group 1 or 2.
- 2.10 METAL FRAMING ANCHORS
- A. General: Provide framing anchors made from metal indicated, of structural capacity, type, and size indicated, and as follows:
 - 1. Research/Evaluation Reports: Provide products acceptable to authorities having jurisdiction and for which model code research/evaluation reports exist that show compliance of metal framing anchors, for application indicated, with building code in effect for Project.
 - 2. Allowable Design Loads: Provide products with allowable design loads, as published by manufacturer that meet or exceed those indicated. Manufacturer's published values shall be determined from empirical data or by rational engineering analysis and demonstrated by comprehensive testing performed by a qualified independent testing agency.
 - B. Galvanized Steel Sheet: Hot-dip, zinc-coated steel sheet complying with ASTM A 653/A 653M, G60 coating designation.

- C. Stainless-Steel Sheet: ASTM A 666, Type 304.
- D. Use for exterior locations and where indicated.
- E. Joist Hangers: U-shaped joist hangers with 2-inch- long seat and 1-1/4-inch- wide nailing flanges at least 85 percent of joist depth.
- F. Thickness: 0.050 inch.
- G. I-Joist Hangers: U-shaped joist hangers with 2-inch- long seat and 1-1/4-inch- wide nailing flanges full depth of joist. Nailing flanges provide lateral support at joist top chord.
- H. Thickness: 0.050 inch.
- I. Top Flange Hangers: U-shaped joist hangers, full depth of joist, formed from metal strap with tabs bent to extend over and be fastened to supporting member.
- J. Strap Width: 1-1/2 inches.
- K. Thickness: 0.050 inch.
- L. Bridging: Rigid, V-section, nailless type, 0.062 inch thick, length to suit joist size and spacing.
- M. Post Bases: Adjustable-socket type for bolting in place with standoff plate to raise post 1 inch above base and with 2-inch- minimum side cover, socket 0.062 inch thick, and standoff and adjustment plates 0.108 inch thick.
- N. Joist Ties: Flat straps, with holes for fasteners, for tying joists together over supports.
- O. Width: 3/4 inch.
- P. Thickness: 0.050 inch.
- Q. Length: 16 inches.
- R. Rafter Tie-Downs: Bent strap tie for fastening rafters or roof trusses to wall studs below, 1-1/2 inches wide by 0.050 inch thick. Tie fastens to side of rafter or truss, face of top plates, and side of stud below.
- S. Rafter Tie-Downs (Hurricane or Seismic Ties): Bent strap tie for fastening rafters or roof trusses to wall studs below, 2-1/4 inches wide by 0.062 inch thick. Tie fits over top of rafter or truss and fastens to both sides of rafter or truss, face of top plates, and side of stud below.
- T. Floor-to-Floor Ties: Flat straps, with holes for fasteners, for tying upper floor wall studs to band joists and lower floor studs, 1-1/4 inches wide by 0.050 inch thick by 36 inches long.
- U. Hold-Downs: Brackets for bolting to wall studs and securing to foundation walls with anchor bolts or to other hold-downs with threaded rods and designed with first of two bolts placed seven bolt diameters from reinforced base.
- V. Wall Bracing: T-shaped bracing made for letting into studs in saw kerf, 1-1/8 inches wide by 9/16 inch deep by 0.034 inch thick with hemmed edges.
- W. Wall Bracing: Angle bracing made for letting into studs in saw kerf, 15/16 by 15/16 by 0.040 inch thick with hemmed edges.

2.11 MISCELLANEOUS MATERIALS

- A. Building Paper: Asphalt-saturated organic felt complying with ASTM D 226, Type I (No. 15 asphalt felt), unperforated.
- B. Building Wrap: Air-retarder sheeting made from polyolefins; cross-laminated films, woven strands, or spun-bonded fibers; coated or uncoated; with or without perforations; and complying with ASTM E 1677, Type I.
 1. Thickness: Not less than **3 mils**
 2. Permeance: Not less than **10 perms**
 3. Flame-Spread Index: 25 or less per ASTM E 84.
 4. Allowable Exposure Time: Not less than three months.
- C. Building Wrap Tape: Pressure-sensitive plastic tape recommended by building wrap manufacturer for sealing joints and penetrations in building wrap.
- D. Sheathing Tape: Pressure-sensitive plastic tape for sealing joints and penetrations in sheathing and recommended by sheathing manufacturer for use with type of sheathing required.

- E. Sill-Sealer Gaskets: Glass-fiber-resilient insulation, fabricated in strip form, for use as a sill sealer; 1-inch nominal thickness, compressible to 1/32 inch; selected from manufacturer's standard widths to suit width of sill members indicated.
- F. Sill-Sealer Gaskets: Closed-cell neoprene foam, 1/4 inch thick, selected from manufacturer's standard widths to suit width of sill members indicated.
- G. Adhesives for Field Gluing Panels to Framing: Formulation complying with ASTM D 3498 that is approved for use with type of construction panel indicated by both adhesive and panel manufacturers.
- H. Water-Repellent Preservative: NWWDA-tested and -accepted formulation containing 3-iodo-2-propynyl butyl carbamate, combined with an insecticide containing chloropyrifos as its active ingredient.

PART 3 - EXECUTION

3.1 INSTALLATION, GENERAL

- A. Set rough carpentry to required levels and lines, with members plumb, true to line, cut, and fitted. Fit rough carpentry to other construction; scribe and cope as needed for accurate fit. Locate furring, nailers, blocking, grounds, and similar supports to comply with requirements for attaching other construction.
- B. Do not use materials with defects that impair quality of rough carpentry or pieces that are too small to use with minimum number of joints or optimum joint arrangement.
- C. Apply field treatment complying with AWPA M4 to cut surfaces of preservative-treated lumber and plywood.
- D. Securely attach rough carpentry work to substrate by anchoring and fastening as indicated, complying with the following:
 1. CABO NER-272 for power-driven fasteners.
 2. Published requirements of metal framing anchor manufacturer.
 3. Table 23-II-B-1, "Nailing Schedule," and Table 23-II-B-2, "Wood Structural Panel Roof Sheathing Nailing Schedule," in the Uniform Building Code.
 4. Table 2305.2, "Fastening Schedule," in the BOCA National Building Code.
 5. Table 2306.1, "Fastening Schedule," in the Standard Building Code.
 6. Table 602.3(1), "Fastener Schedule for Structural Members," and Table 602.3(2), "Alternate Attachments," in the International One- and Two-Family Dwelling Code.
- E. Use common wire nails, unless otherwise indicated. Select fasteners of size that will not fully penetrate members where opposite side will be exposed to view or will receive finish materials. Make tight connections between members. Install fasteners without splitting wood; predrill as required.
- F. Use finishing nails for exposed work, unless otherwise indicated. Countersink nail heads and fill holes with wood filler.

3.2 WOOD GROUND, SLEEPER, BLOCKING, AND NAILER INSTALLATION

- A. Install where indicated and where required for screening or attaching other work. Form to shapes indicated and cut as required for true line and level of attached work. Coordinate locations with other work involved.
- B. Attach items to substrates to support applied loading. Recess bolts and nuts flush with surfaces, unless otherwise indicated. Build anchor bolts into masonry during installation of masonry work. Where possible, secure anchor bolts to formwork before concrete placement.
- C. Provide permanent grounds of dressed, pressure-preservative-treated, key-beveled lumber not less than 1-1/2 inches wide and of thickness required to bring face of ground to exact thickness of finish material. Remove temporary grounds when no longer required.

3.3 WOOD FRAMING INSTALLATION, GENERAL

- A. Framing Standard: Comply with AFPA's "Manual for Wood Frame Construction," unless otherwise indicated.
- B. Framing with Engineered Wood Products: Install engineered wood products to comply with manufacturer's written instructions.

- C. Do not splice structural members between supports.
- D. Where built-up beams or girders of 2-inch nominal- dimension lumber on edge are required, fasten together with 2 rows of 20d nails spaced not less than 32 inches o.c. Locate one row near top edge and other near bottom edge.

3.4 WALL AND PARTITION FRAMING INSTALLATION

- A. General: Arrange studs so wide face of stud is perpendicular to direction of wall or partition and narrow face is parallel. Provide single bottom plate and double top plates using members of 2-inch nominal thickness whose widths equal that of studs, except single top plate may be used for non-load-bearing partitions. Anchor or nail plates to supporting construction, unless otherwise indicated.
- B. For exterior walls, provide 2-by-6-inch nominal- size wood studs spaced 24 inches o.c., unless otherwise indicated.
- C. For interior partitions and walls, provide 2-by-4-inch nominal-size wood studs spaced 16 inches o.c., unless otherwise indicated.
- D. Construct corners and intersections with three or more studs. Provide blocking and framing as indicated and as required to support facing materials, fixtures, specialty items, and trim.
- E. Provide continuous horizontal blocking at midheight of partitions more than 96 inches high, using members of 2-inch nominal thickness and of same width as wall or partitions.
- F. Fire block concealed spaces of wood-framed walls and partitions at each floor level and at ceiling line of top story. Where fire blocking is not inherent in framing system used, provide closely fitted wood blocks of 2-inch nominal- thick lumber of same width as framing members.
- G. Frame openings with multiple studs and headers. Provide nailed header members of thickness equal to width of studs. Set headers on edge and support on jamb studs.
 - 1. For non-load-bearing partitions, provide double-jamb studs with headers not less than **4-inch nominal** depth for openings **48 inches** and less in width, **6-inch nominal** depth for openings **48 to 72 inches** in width, **8-inch nominal** depth for openings **72 to 120 inches** in width, and not less than **10-inch nominal** depth for openings **10 to 12 feet** in width.
 - 2. For load-bearing walls, provide double-jamb studs for openings **72 inches** and less in width, and triple-jamb studs for wider openings. Provide headers of depth indicated.
- H. Provide bracing in exterior walls, at both walls of each external corner, full-story height, unless otherwise indicated. Provide one of the following:
- I. Provide bracing in walls, at locations indicated, full-story height, unless otherwise indicated. Provide one of the following:
 - 1. Diagonal bracing at 45-degree angle using let-in **1-by-4-inch nominal-** size boards.
 - 2. Diagonal bracing at 45-degree angle using metal bracing.
 - 3. Plywood panels not less than **48 by 96 inches** applied vertically.
 - 4. Oriented-strand-board panels not less than **48 by 96 inches** applied vertically.
 - 5. Particleboard sheathing panels not less than **48 by 96 inches** applied vertically.
 - 6. In lieu of bracing at corners or at locations indicated, continuous gypsum sheathing may be provided in panels not less than **48 by 96 inches** applied vertically.
 - 7. In lieu of bracing at corners or at locations indicated, continuous fiberboard sheathing, intermediate type, may be provided in panels not less than **48 by 96 inches** applied vertically.

3.5 CEILING JOIST AND RAFTER FRAMING INSTALLATION

- A. Ceiling Joists: Install ceiling joists with crown edge up and complying with requirements specified above for floor joists. Face nail to ends of parallel rafters.
- B. Where ceiling joists are at right angles to rafters, provide additional short joists parallel to rafters from wall plate to first joist; nail to ends of rafters and to top plate and nail to first joist or anchor with framing anchors or metal straps. Provide 1-by-8-inch nominal- size or 2-by-4-inch nominal- size stringers spaced 48 inches o.c. crosswise over main ceiling joists.
- C. Rafters: Notch to fit exterior wall plates and use metal framing anchors. Double rafters to form headers and trimmers at openings in roof framing, if any, and support with metal hangers. Where rafters abut at ridge, place directly opposite each other, and nail to ridge member or use metal ridge hangers.

1. At valleys, provide double-valley rafters of size indicated or, if not indicated, of same thickness as regular rafters and **2 inches** deeper. Bevel ends of jack rafters for full bearing against valley rafters.
 2. At hips, provide hip rafter of size indicated or, if not indicated, of same thickness as regular rafters and **2 inches** deeper. Bevel ends of jack rafters for full bearing against hip rafter.
- D. Provide collar beams (ties) as indicated or, if not indicated, provide **1-by-6-inch nominal**-size boards between every third pair of rafters, but not more than **48 inches** o.c. Locate below ridge member, at third point of rafter span. Cut ends to fit roof slope and nail to rafters.
- E. Provide special framing as indicated for eaves, overhangs, dormers, and similar conditions, if any.
- 3.6 FIBERBOARD SHEATHING INSTALLATION
- A. Fasten fiberboard sheathing panels to intermediate supports and then at edges and ends. Use galvanized roofing nails; comply with manufacturer's recommended spacing and referenced fastening schedule. Drive fasteners flush with surface of sheathing and locate perimeter fasteners at least 3/8 inch from edges and ends.
 - B. Install sheathing vertically with long edges parallel to, and centered over, studs. Install solid wood blocking where end joints do not occur over framing. Allow 1/8-inch open space between edges and ends of adjacent units. Stagger horizontal joints, if any.
 - C. Cover sheathing as soon as practical after installation to prevent deterioration from wetting.
- 3.7 BUILDING PAPER APPLICATION
- A. Apply building paper horizontally with 2-inch overlap and 6-inch end lap; fasten to sheathing with galvanized staples or roofing nails. Cover upstanding flashing with 4-inch overlap.
- 3.8 BUILDING WRAP APPLICATION
- A. Cover wall sheathing with building wrap as indicated.
 1. Comply with manufacturer's written instructions.
 2. Cover upstanding flashing with **4-inch** overlap.
 3. Seal seams, edges, and penetrations with tape.
 4. Extend into jambs of openings and seal corners with tape.
- 3.9 SHEATHING TAPE APPLICATION
- A. Apply sheathing tape to joints between sheathing panels and at items penetrating sheathing. Apply at upstanding flashing to overlap both flashing and sheathing.

END OF SECTION 06100

SECTION 06112

FRAMING AND SHEATHING

PART 1 – GENERAL

1.01 SECTION INCLUDES

- A. Structural roof framing.
- B. 2 x 4, 2 x 6 stud wall framing.
- C. Wall & Roof sheathing.
- D. Miscellaneous framing and sheathing.
- E. Telephone and electrical panel boards.
- F. Concealed wood blocking for support of wall cabinets, wood trim, and rails.

1.02 GENERAL

- A. All notes or specifications on street drawings shall override any discrepancies listed.

1.03 REFERENCES

- A. ALSC: American Lumber Standards Committee - Softwood, Lumber Standards.
- B. APA: American Plywood Association.
- C. NFPA: National Forest Products Association.

1.04 QUALITY ASSURANCE

- A. Perform Work in accordance with the following agencies:
 - 1. Lumber Grading Agency: Certified by ALSC.
 - 2. Plywood Grading Agency: Certified by APA.

PART 2 – PRODUCTS

2.01 LUMBER MATERIALS

- A. Lumber Grading Rules: NFPA.
- B. Truss Framing: Stress Group, Douglas Fir species, standard grade, 2" x 6" size classification, 19 percent maximum moisture content.
- C. Studding: Stress Group, Douglas Fir species, standard grade, 2" x 6" size classification, 19 percent maximum moisture content.

2.02 SHEATHING MATERIALS

- A. Roof; Plywood Roof Sheathing: APA Rated Sheathing, AC faces.
- B. Wall; ZIP System R-6 Insulated Panel**

2.03 ACCESSORIES

- A. Fasteners and Anchors:
 - 1. Fasteners: Hot-dipped galvanized steel for high humidity and treated wood locations, unfinished steel elsewhere.
 - 2. Drywall Screws: Bugle head, hardened steel, power driven type, length three times thickness of sheathing.
 - 3. Anchors: Toggle bolt type for anchorage to hollow masonry. Expansion shield and lag bolt type for anchorage to solid masonry or concrete. Bolt or ballistic fastener for anchorages to steel.
- B. Sill Gasket on Top of Foundation Wall: All as approved by Architect.
- C. Building Paper: No. 15 asphalt felt.

PART 3 – EXECUTION

3.01 FRAMING

- A. Set structural members level and plumb, in correct position.
- B. Make provisions for erection loads, and for sufficient temporary bracing to maintain structure safe, plumb, and in true alignment until completion of erection and installation of permanent bracing.
- C. Place horizontal members flat, crown side up.
- D. Construct load bearing framing members, full length without splices.
- E. Double members at openings over 24 inches wide. Space short studs over and under opening to stud spacing.

- F. Construct double joist headers at floor and ceiling openings and under wall stud partitions that are parallel to floor joists. Frame rigidly into joists.
- G. Bridge joists framing in excess of 8 feet span as detailed at mid-span. Fit bridging at ends of members.
- H. Place full width continuous sill flashings under framed walls on cementitious foundations. Lap flashing joint 4 inches.
- I. Place sill gasket directly on sill flashing. Puncture gasket clean and fit tight to protruding foundation anchor bolts.

3.02 SHEATHING

- A. Secure roof sheathing perpendicular to framing members with ends staggered and sheet ends over firm bearing. Use sheathing clips between sheets between roof framing members. Provide solid edge blocking between sheets.
- B. Secure wall sheathing with long dimension (parallel) to wall studs, with ends over firm bearing and staggered.
- C. Place building paper horizontally over wall sheathing, weather lap edges, and ends.
- D. Install telephone and electrical panel boards with plywood sheathing material where required. Over size the panel by 12 inches on all sides.

3.03 TOLERANCES

- A. Framing Members: 1/4 inch from true position, maximum.

3.04 SCHEDULES

- A. **Above Grade Truss, Rafter, and Stud Framing: S/P/F species, 19 percent maximum moisture content, unless noted otherwise on drawings.**
- B. **Sloped Roof Sheathing: 15/32 inch thick plywood, 24 x 48 inch sized sheets, square edges; appearance grade facing inward with proper span rating. Reference structural drawings for specific locations.**
- C. **Blocking: S/P/F species, pressure preservative treatment.**
- D. **Wall Sheathing: ZIP System R-6 Insulated Panel, 48' x 96' sized sheets, nominal 1-1/2" thick, install per ZIP system R-Sheathing Installation Manual, Reference structural drawings for specific locations.**
- E. **Wall Siding: reference drawings.**

END OF SECTION 06112

SECTION 06114

WOOD BLOCKING

PART 1 GENERAL

1.01 SECTION INCLUDES

- A. Roof curbs and cants.
- B. Blocking in wall and roof openings.
- C. Wood furring and grounds.
- D. Concealed wood blocking for support of toilet and bath accessories, wall cabinets, and wood trim.
- E. Telephone and electrical panel boards.

PART 2 PRODUCTS

2.01 MATERIALS

- A. Miscellaneous Blocking: Minimum stud grade.
- B. Plywood: APA Rated Sheathing, Grade C-D; Exposure Durability 1; sanded.

2.02 ACCESSORIES

- A. Fasteners and Anchors:
 - 1. Fasteners: Hot-dipped galvanized steel for high humidity and treated wood locations, unfinished steel elsewhere.
 - 2. Anchors: Toggle bolt type for anchorage to hollow masonry. Expansion shield and lag bolt type for anchorage to solid masonry or concrete. Bolt or ballistic fastener for anchorages to steel.

PART 3 EXECUTION

3.01 FRAMING

- A. Set members level and plumb, in correct position.
- B. Place horizontal members flat, crown side up.
- C. Space framing and furring 16 inches o.c.

3.02 SHEATHING

- A. Secure sheathing to framing members with ends over firm bearing and staggered.
- B. Install telephone and electrical panel boards with plywood sheathing material where required. Over size the panel by 12 inches on all sides.

END OF SECTION 06114

SECTION 061600

SHEATHING (ZIP SYSTEM INSULATED PANELS)

PART 1 - GENERAL

1.1 RELATED DOCUMENTS

- A. Structural drawings & notes take precedence over these specs, please reference drawings.
- B. Drawings and general provisions of the Contract, including General and Supplementary Conditions and Division 01 Specification Sections, apply to this Section.

1.2 SUMMARY

- A. Section Includes:
 - 1. Combination wall sheathing, water resistive barrier and air barrier.
 - 2. Combination insulated wall sheathing, water resistive barrier and air barrier
 - 3. Combination roof sheathing and roof underlayment.
 - 4. Self-adhering flexible flashing.
 - 5. Liquid-applied flashing membrane.
- B. Related Requirements:
 - 1. Section 061000 "Rough Carpentry".
 - 2. Section 072500 "Weather Barriers" for water-resistive barrier applied over wall sheathing.
 - 3. Section 072700 "Air Barriers".

1.3 ACTION SUBMITTALS

- A. Product Data: For each type of process and factory-fabricated product. Indicate component materials and dimensions and include construction and application details.
 - 1. For panels with integral water resistive barrier, include data on air/-moisture-infiltration protection based on testing according to referencing standards.

1.4 QUALITY ASSURANCE

- A. Manufacturer Qualifications: Capable of demonstrating that all wood procurement operations are conducted in accordance with procedures and policies of the Sustainable Forestry Initiative (SFI) Program.
- B. Code Compliance: Comply with requirements of the following:
 - 1. International Code Council (ICC), ICC-ESR1473 (ZIP System Roof Sheathing).
 - 2. International Code Council (ICC), ICC-ESR1474 (ZIP System Wall Sheathing).
 - 3. International Code Council (ICC), ICC-ESR2227 (ZIP System Tape).
 - 4. Florida Building Code Compliance: Provide sheathing complying with Florida Building Code product and installation requirements for locations outside of high velocity wind zone.

1.5 DELIVERY, STORAGE, AND HANDLING

- A. Outdoor Storage: Comply with manufacturer's recommendations.
 - 1. Set panel bundles on supports to keep off ground.
 - 2. Cover panels loosely with waterproof protective material.
 - 3. Anchor covers on top of stack, but keep away from sides and bottom to assure adequate air circulation.
 - 4. When high moisture conditions exist, cut banding on panel stack to prevent edge damage.

1.6 WARRANTY

- A. Special Warranty: Manufacturer's standard form in which manufacturer agrees to repair or replace components of sheathing system that fail due to manufacturing defects within specified warranty period.
 - 1. Construction Period Warranty: Manufacturer shall warrant the panels and tape for weather exposure for a period of 180 days from installation.
 - 2. System Warranty Period: 30 years from date of Substantial Completion.

PART 2 - PRODUCTS

2.1 PERFORMANCE REQUIREMENTS

- A. Fire-Test-Response Characteristics: For assemblies with fire-resistance ratings, provide materials and construction identical to those of assemblies tested for fire resistance per ASTM E 119 by a testing and inspecting agency acceptable to authorities having jurisdiction.
 - 1. Fire-Resistance Ratings: Indicated by design designations from UL's "Fire Resistance Directory."

2.2 WOOD PANEL PRODUCTS

- A. Oriented Strand Board: DOC PS 2-10.
- B. Thickness: As needed to comply with drawings & requirements specified, but not less than thickness indicated. Thickness shall satisfy minimum and maximum requirements for referenced performance category.
- C. **Insulated R6 wall sheathing indicated at all exterior walls.** Rigid Foam Plastic Insulating Board: Rigid polyisocyanurate foam core complying with ASTM C1289 Type II, Class 2, and ICC-ES AC12, with coated glass fiber facers on both sides, with the following characteristics:
 - 1. Nominal Density: 2.0 pcf (32 kg/cu. m).
 - 2. Compressive Strength, ASTM D1621: Not less than 20 psi (150 kPa).
 - 3. Vapor Permeance, ASTM E96/E96M: Less than 1.0 perm.
 - 4. Edge Configuration: Square finished.
- D. Factory mark panels to indicate compliance with applicable standard.

2.3 COMBINATION WALL SHEATHING, WATER-RESISTIVE BARRIER, INSULATION AND AIR BARRIER

- A. **Insulated R6 wall sheathing indicated at all exterior walls.** Rigid Foam Plastic Insulating Board: Rigid polyisocyanurate foam core complying with ASTM C1289 Type II, Class 2, and ICC-ES AC12, with coated glass fiber facers on both sides, with the following characteristics:
 - 1. Nominal Density: 2.0 pcf (32 kg/cu. m).
 - 2. Compressive Strength, ASTM D1621: Not less than 20 psi (150 kPa).
 - 3. Vapor Permeance, ASTM E96/E96M: Less than 1.0 perm.
 - 4. Edge Configuration: Square finished.
- B. Oriented-Strand-Board Wall Sheathing: With integral water-resistive barrier, Exposure 1 sheathing.
 - 1. Basis-of-Design Product: Subject to compliance with requirements, provide Huber Engineered Woods LLC; ZIP System Roof and Wall Sheathing or a comparable product as submitted and approved as equal.
 - 2. Span Rating, Panel Grade and Performance Category: 32/16 Structural 1; 1/2 Performance Category.
 - 3. Edge Profile: Square edge.
 - 4. Provide fastening guide on top panel surface with pre-spaced fastening symbols for 16-inches (406 mm) and 24-inches (610 mm) on centers spacings.
 - 5. Performance Standard: DOC PS2-10 and ICC-ES ESR-1474.
 - 6. Factory laminated integral water-resistive barrier facer.
 - 7. Perm Rating of Integral Water-Resistive Barrier: 12-16 perms.

8. Assembly maximum air leakage of 0.0072 cfm/sq. ft. (0.037 L/s x sq. m) infiltration and 0.0023 cfm/ sq. ft. (0.012 L/s x sq. m)exfiltration at a pressure differential of 1.57 (psf 75 Pa).
9. Exposure Time: Designed to resist weather exposure for 180 days.

2.4 COMBINATION ROOF SHEATHING AND ROOF UNDERLAYMENT

- A. Oriented-Strand-Board Roof Sheathing: With integral water-resistive barrier, Exposure 1, Structural I.
 1. Basis-of-Design Product: Subject to compliance with requirements, provide Huber Engineered Woods LLC; ZIP System Roof and Wall Sheathing or a comparable product as submitted and approved as equal.
 2. Span Rating, Panel Grade and Performance Category: 40/20; Structural 1; 5/8 Performance Category.
 3. Edge Profile: Tongue and groove.
 4. Provide fastening guide on top panel surface with pre-spaced fastening symbols for 16-inches (406 mm) and 24-inches (610 mm) on center spacings.
 5. Performance Standard: DOC PS2-10 and ICC-ES ESR-1473.
 6. Factory laminated integral roofing underlayment facer.
 7. Exposure Time: Designed to resist weather exposure for 180 days.
- B. 7/16 Performance Category ZIP System Roof and Wall Sheathing requires edge support (Approved H-clips or blocking) when installed on roof supports spaced greater than 16-inches. Approved Panel edge clips are Simpson Strong-Tie PSCA7/16, PSCL7/16, and TAMLYN PCS7/16. No other brand or model of panel edge clip may be used with 7/16 ZIP System Sheathing. Tongue-and-Groove edge profile is only available in 5/8 Performance Category ZIP System Sheathing.
- C. Panel Edge Clips: Provide panel edge clips approved for application in accordance with code approvals and panel manufacturer's written instructions.

2.5 FASTENERS

- A. General: Provide fasteners of size and type that comply with requirements specified in this article by the authority having jurisdiction, International Building Code, International Residential Code, Wood Frame Construction manual, and National Design Specification.

2.6 MISCELLANEOUS MATERIALS

- A. Self-Adhering Seam and Flashing Tape: Pressure-sensitive, self-adhering, cold-applied, proprietary seam tape consisting of polyolefin film with acrylic adhesive.
 1. Basis-of-Design Product: Subject to compliance with requirements provide Huber Engineered Woods; ZIP System Seam and Flashing Tape or comparable product as submitted and approved as equal.
 2. Thickness: 0.012 inch (0.3 mm).
 3. Width: 6 inch (152.4 mm).
 4. Code Compliance: Comply with requirements of authorities having jurisdiction and ICC Evaluation Service, Inc. "AC148 - Acceptance Criteria for Flexible Flashing Materials."
 5. International Code Council (ICC), ICC-ES ESR2227 (ZIP System Tape).
 6. American Architectural Manufacturer's Association; AAMA 711.

PART 3 - EXECUTION

3.1 INSTALLATION, GENERAL

- A. Do not use materials with defects that impair quality of sheathing or pieces that are too small to use with minimum number of joints or optimum joint arrangement.
- B. Cut panels at penetrations, edges, and other obstructions of work; fit tightly against abutting construction unless otherwise indicated.

- C. Securely attach to substrate by fastening as indicated, complying with the following:
 - 1. ICC-ES 1539 or NES NER-272 for power-driven fasteners.
 - 2. Chapter 23 in ICC's "International Building Code."
 - 3. Table R602.3 (1), "Fastener Schedule for Structural Members," and Table R602.3 (2), "Alternate Attachments," in ICC's "International Residential Code for One- and Two-Family Dwellings."
- D. Use common wire nails unless otherwise indicated. Select fasteners of size that will not fully penetrate members where opposite side will be exposed to view or will receive finish materials. Make tight connections. Install fasteners without splitting wood.
- E. Coordinate wall and roof sheathing installation with flashing and joint-sealant installation so these materials are installed in sequence and manner that prevent exterior moisture from passing through completed assembly.
- F. Do not bridge building expansion joints; cut and space edges of panels to match spacing of structural support elements.
- G. Only mechanically attached and drainable EIFS and exterior insulation should be used with ZIP System wall sheathing.

3.2 WOOD STRUCTURAL PANEL INSTALLATION

- A. General: Comply with applicable recommendations in American Wood Council, "ASD/LRFD Manual for Engineered Wood Construction," 2012 edition for types of structural-use panels and applications indicated.
- B. Fastening Methods: Fasten panels as indicated below:
 - 1. Wall and Roof Sheathing:
 - a. Nail or staple to wood framing.
 - b. Screw to cold-formed metal framing.
 - c. Space panels 1/8 inch (3 mm) apart at edges and ends.
 - d. Install fasteners 3/8 inch (9.5 mm) to 1/2 inch (12.7 mm) from panel edges.
 - e. Space fasteners in compliance with requirements of authority having jurisdiction.

3.3 SHEATHING JOINT TREATMENT

- A. Seal sheathing joints according to sheathing manufacturer's written instructions.
 - 1. Apply ZIP System proprietary seam tape to joints between sheathing panels.
 - 2. Utilize ZIP System tape gun or hard rubber roller provided by manufacturer to ensure tape is completely adhered to substrates.

3.4 FLEXIBLE OR LIQUID APPLIED FLASHING INSTALLATION

- A. Apply ZIP System Tape flexible flashing or ZIP System Liquid Flash liquid applied flashing membrane where indicated to comply with manufacturer's written instructions.
 - 1. After flexible flashing tape has been applied, roll surfaces with a hard rubber to ensure that flashing is completely adhered to substrates.
 - 2. Width for Flexible Flashing: 6 inch (154.4 mm).
 - 3. Apply liquid-applied flashing membrane at penetrations, gaps, and cracks to form continuous weathertight surface. Apply liquid membrane according to manufacturer's written instructions. Follow manufacturer's recommendation for integration with ZIP System Tape.

END OF SECTION 061600

SECTION 06176

METAL-PLATE-CONNECTED WOOD TRUSSES

PART 1 - GENERAL

1.1 RELATED DOCUMENTS

- A. Drawings and general provisions of the Contract, including General and Supplementary Conditions and Division 1 Specification Sections, apply to this Section.

1.2 SUMMARY

- A. This Section includes wood roof trusses and truss accessories.
- B. Related Sections include the following:
 - 1. Division 6 Section "Rough Carpentry" for roof sheathing and subflooring and dimension lumber for supplementary framing and permanent bracing.
 - 2. Division 6 Section "Miscellaneous Carpentry" for roof sheathing and subflooring and dimension lumber for supplementary framing and permanent bracing.

1.3 DEFINITIONS

- A. Metal-Plate-Connected Wood Trusses: Planar structural units consisting of metal-plate-connected members fabricated from dimension lumber and cut and assembled before delivery to Project site.
- B. Lumber grading agencies, and the abbreviations used to reference them, include the following:
 - 1. NELMA - Northeastern Lumber Manufacturers Association.
 - 2. NLGA - National Lumber Grades Authority.
 - 3. SPIB - Southern Pine Inspection Bureau.
 - 4. WCLIB - West Coast Lumber Inspection Bureau.
 - 5. WWPA - Western Wood Products Association.

1.4 PERFORMANCE REQUIREMENTS

- A. Structural Performance: Provide metal-plate-connected wood trusses capable of withstanding design loads within limits and under conditions indicated.
 - 1. Design Loads: As indicated.
 - 2. Maximum Deflection Under Design Loads:
 - a. Roof Trusses: Vertical deflection of 1/240 of span.
 - b. Roof Trusses: Horizontal deflection at reactions of 1-1/4 inches.
 - c. Floor Trusses: Vertical deflection of 1/360 of span.

1.5 SUBMITTALS

- A. Product Data: For metal-plate connectors, metal framing anchors, bolts, and fasteners.
 - 1. Include data for wood-preservative treatment from chemical treatment manufacturer and certification by treating plant that treated materials comply with requirements. Indicate type of preservative used, net amount of preservative retained, and chemical treatment manufacturer's written instructions for handling, storing, installing, and finishing treated material.
 - 2. Include data for fire-retardant treatment from chemical treatment manufacturer and certification by treating plant that treated materials comply with requirements, including bending strength, stiffness, and fastener-holding capacity. Include physical properties of treated materials, both before and after exposure to elevated temperatures when tested according to ASTM D 5664.
 - 3. For products receiving a waterborne treatment, include statement that moisture content of treated materials was reduced to levels specified before shipment to Project site.
 - 4. Include copies of warranties from chemical treatment manufacturers for each type of treatment.

- B. Shop Drawings: Show location, pitch, span, camber, configuration, and spacing for each type of truss required; species, sizes, and stress grades of lumber; splice details; type, size, material, finish, design values, orientation, and location of metal connector plates; and bearing details.
 - 1. For installed products indicated to comply with design loads, include structural analysis data signed and sealed by the qualified professional engineer responsible for their preparation.
- C. Material Certificates: For dimension lumber specified to comply with minimum allowable unit stresses. Indicate species and grade selected for each use and design values approved by the American Lumber Standards Committee Board of Review.
- D. Research/Evaluation Reports: For the following, showing compliance with building code in effect for Project:
 - 1. Preservative-treated wood.
 - 2. Fire-retardant-treated wood.
 - 3. Metal-plate connectors.
 - 4. Metal framing anchors.

1.6 QUALITY ASSURANCE

- A. Metal Connector-Plate Manufacturer Qualifications: A manufacturer that is a member of TPI and that complies with TPI quality-control procedures for manufacture of connector plates published in TPI 1.
 - 1. Manufacturer's responsibilities include providing professional engineering services needed to assume engineering responsibility.
 - 2. Engineering Responsibility: Preparation of Shop Drawings and comprehensive engineering analysis by a qualified professional engineer.
- B. Fabricator Qualifications: Shop that participates in a recognized quality-assurance program that involves inspection by SPIB, Timber Products Inspection, TPI, or other independent testing and inspecting agency acceptable to Architect and authorities having jurisdiction.
- C. Source Limitations for Connector Plates: Obtain metal connector plates through one source from a single manufacturer.
- D. Source Limitations for Fire-Retardant-Treated Wood: Obtain each type of fire-retardant-treated wood product through one source from a single producer.
- E. Comply with applicable requirements and recommendations of the following publications:
 - 1. TPI 1, "National Design Standard for Metal Plate Connected Wood Truss Construction."
 - 2. TPI DSB, "Recommended Design Specification for Temporary Bracing of Metal Plate Connected Wood Trusses."
 - 3. TPI HIB, "Commentary and Recommendations for Handling, Installing & Bracing Metal Plate Connected Wood Trusses."
- F. Wood Structural Design Standard: Comply with applicable requirements in AFPA's "National Design Specifications for Wood Construction" and its "Supplement."

1.7 DELIVERY, STORAGE, AND HANDLING

- A. Comply with TPI recommendations to avoid damage and lateral bending. Provide for air circulation around stacks and under coverings.
- B. Inspect trusses showing discoloration, corrosion, or other evidence of deterioration. Discard and replace trusses that are damaged or defective.

1.8 COORDINATION

- A. Time delivery and erection of trusses to avoid extended on-site storage and to avoid delaying progress of other trades whose work must follow erection of trusses.

PART 2 - PRODUCTS

2.1 MANUFACTURERS

- A. Available Manufacturers: Subject to compliance with requirements, manufacturers offering products that may be incorporated into the Work include, but are not limited to, the following:

2.2 DIMENSION LUMBER

- A. Lumber: DOC PS 20 and applicable rules of lumber grading agencies certified by the American Lumber Standards Committee Board of Review.
 - 1. Factory mark each piece of lumber with grade stamp of grading agency.
 - 2. For exposed lumber indicated to receive natural or stained finish, omit grade stamp and provide certificates of grade compliance issued by grading agency.
 - 3. Provide dressed lumber, S4S, manufactured to actual sizes required by DOC PS 20 for moisture content specified.
 - 4. Provide dry lumber with 19 percent maximum moisture content at time of dressing.
 - 5. Provide dry lumber with 15 percent maximum moisture content at time of dressing.
- B. Grade and Species: Provide dimension lumber of any species for truss chord and web members, graded visually or mechanically, and capable of supporting required loads without exceeding allowable design values according to AFPA's "National Design Specifications for Wood Construction" and its "Supplement."
 - 1. Grade and Species: Provide visually graded dimension lumber for truss chord and web members.

2.3 WOOD-PRESERVATIVE-TREATED LUMBER

- A. Preservative Treatment by Pressure Process: AWPAC2, except that lumber that is not in contact with the ground and is continuously protected from liquid water may be treated according to AWPAC31 with inorganic boron (SBX).
 - 1. Preservative Chemicals: Acceptable to authorities having jurisdiction.
 - 2. For exposed items indicated to receive a stained or natural finish, use chemical formulations that do not require incising, contain colorants, bleed through, or otherwise adversely affect finishes.
- B. Kiln-dry material after treatment to a maximum moisture content of 19 percent. Do not use material that is warped or does not comply with requirements for untreated material.
- C. Mark each treated item with the treatment quality mark of an inspection agency approved by the American Lumber Standards Committee Board of Review.
 - 1. For exposed lumber indicated to receive a stained or natural finish, omit marking and provide certificates of treatment compliance issued by inspection agency.

2.4 FIRE-RETARDANT-TREATED WOOD

- A. General: Where fire-retardant-treated wood is indicated, provide wood that complies with performance requirements in AWPAC20. Identify fire-retardant-treated wood with appropriate classification marking of UL, U.S. Testing, Timber Products Inspection, or another testing and inspecting agency acceptable to authorities having jurisdiction.
 - 1. Use treatment for which chemical manufacturer publishes physical properties of treated wood after exposure to elevated temperatures, when tested by a qualified independent testing agency according to ASTM D 5664.
 - 2. Use treatment that does not promote corrosion of metal fasteners.
 - 3. Use Exterior type for exterior locations and where indicated.
 - 4. Use Interior Type A High Temperature (HT), unless otherwise indicated.

- B. For exposed items indicated to receive a stained or natural finish, use chemical formulations that do not bleed through, contain colorants, or otherwise adversely affect finishes.

2.5 METAL CONNECTOR PLATES

- A. General: Fabricate connector plates to comply with TPI 1 from metal complying with requirements indicated below:
- B. Hot-Dip Galvanized Steel Sheet: ASTM A 653/A 653M, **G60** coating designation; Designation SS, Grade 33, and not less than **0.036 inch** thick.
- C. Electrolytic Zinc-Coated Steel Sheet: ASTM A 591/A 591M, **80Z** coating designation; ASTM A 570/A 570M, Structural Steel (SS), Grade 33, and not less than **0.047 inch** thick.
- D. Aluminum-Zinc Alloy-Coated Steel Sheet: ASTM A 792/A 792M, **AZ50** coating designation; Structural Steel (SS), Grade 33, and not less than **0.036 inch** thick.

2.6 FASTENERS

- A. General: Provide fasteners of size and type indicated that comply with requirements specified in this Article for material and manufacture.
- B. Nails, Wire, Brads, and Staples: FS FF-N-105.
- C. Power-Driven Fasteners: CABO NER-272.
- D. Wood Screws: ASME B18.6.1.
- E. Lag Bolts: **ASME B18.2.1**.
- F. Bolts: Steel bolts complying with **ASTM A 307, Grade A** with **ASTM A 563** hex nuts and, where indicated, flat washers.
- G. Expansion Anchors: Anchor bolt and sleeve assembly of material indicated below with capability to sustain, without failure, a load equal to 6 times the load imposed when installed in unit masonry assemblies and equal to 4 times the load imposed when installed in concrete as determined by testing per ASTM E 488 conducted by a qualified independent testing and inspecting agency.
 1. Material: Carbon-steel components, zinc plated to comply with ASTM B 633, Class Fe/Zn 5.
 2. Material: Stainless steel with bolts and nuts complying with ASTM F 593 and ASTM F 594, Alloy Group 1 or 2.

2.7 METAL FRAMING ANCHORS

- A. General: Provide framing anchors made from metal indicated, of structural capacity, type, and size indicated, and as follows:
 1. Research/Evaluation Reports: Provide products acceptable to authorities having jurisdiction and for which model code research/evaluation reports exist that show compliance of metal framing anchors, for application indicated, with building code in effect for Project.
 2. Allowable Design Loads: Provide products with allowable design loads, as published by manufacturer that meet or exceed those indicated. Manufacturer's published values shall be determined from empirical data or by rational engineering analysis and demonstrated by comprehensive testing performed by a qualified independent testing agency.
- B. Galvanized Steel Sheet: Hot-dip, zinc-coated steel sheet complying with ASTM A 653/A 653M, **G60** coating designation.
- C. Stainless-Steel Sheet: ASTM A 666, Type [**304**] [**316**].
 1. Use for exterior locations and where indicated.
- D. Truss Tie-Downs: Bent strap tie for fastening roof trusses to wall studs below, **1-1/2 inches** wide by **0.050 inch** thick. Tie fastens to side of truss, face of top plates, and side of stud below.

- E. Truss Tie-Downs (Hurricane or Seismic Ties): Bent strap tie for fastening roof trusses to wall studs below, 2-1/4 inches wide by 0.062 inch thick. Tie fits over top of truss and fastens to both sides of truss, face of top plates, and side of stud below.
- F. Roof Truss Clips: Angle clips for bracing bottom chord of roof trusses at non-load-bearing walls, 1-1/4 inches wide by 0.050 inch thick. Clip is fastened to truss through slotted holes to allow for truss deflection.

2.8 MISCELLANEOUS MATERIALS

- A. Galvanizing Repair Paint: SSPC-Paint 20 or DOD-P-21035, with dry film containing a minimum of 94 percent zinc dust by weight.

2.9 FABRICATION

- A. Cut truss members to accurate lengths, angles, and sizes to produce close-fitting joints.
- B. Fabricate metal connector plates to sizes, configurations, thicknesses, and anchorage details required to withstand design loads for types of joint designs indicated.
- C. Assemble truss members in design configuration indicated; use jigs or other means to ensure uniformity and accuracy of assembly with joints closely fitted to comply with tolerances in TPI 1. Position members to produce design camber indicated.
 - 1. Fabricate wood trusses within manufacturing tolerances in TPI 1.
- D. Connect truss members by metal connector plates located and securely embedded simultaneously in both sides of wood members by air or hydraulic press.

PART 3 - EXECUTION

3.1 INSTALLATION

- A. Install wood trusses only after supporting construction is in place and is braced and secured.
- B. Before installing, splice trusses delivered to Project site in more than one piece.
- C. Hoist trusses in place by lifting equipment suited to sizes and types of trusses required, exercising care not to damage truss members or joints by out-of-plane bending, or other causes.
- D. Install and brace trusses according to TPI recommendations and as indicated.
- E. Install trusses plumb, square, and true to line and securely fasten to supporting construction.
- F. Space trusses as indicated; adjust and align trusses in location before permanently fastening.
- G. Anchor trusses securely at bearing points; use metal framing anchors. Install fasteners through each fastener hole in metal framing anchor according to manufacturer's fastening schedules and written instructions.
- H. Securely connect each truss ply required for forming built-up girder trusses.
 - 1. Anchor trusses to girder trusses as indicated.
- I. Install and fasten permanent bracing during truss erection and before construction loads are applied. Anchor ends of permanent bracing where terminating at walls or beams.
 - 1. Install and fasten strongback bracing vertically against vertical web of parallel-chord floor trusses at centers indicated.
- J. Install wood trusses within installation tolerances in TPI 1.
- K. Do not cut or remove truss members.
- L. Replace wood trusses that are damaged or do not meet requirements.
 - 1. Do not alter trusses in field.

3.2 REPAIRS AND PROTECTION

- A. Repair damaged galvanized coatings on exposed surfaces with galvanized repair paint according to ASTM A 780 and manufacturer's written instructions.
- B. Protective Coating: Clean and prepare exposed surfaces of metal connector plates. Brush apply primer, when part of coating system, and one coat of protective coating.
 - 1. Apply materials to provide minimum dry film thickness recommended by coating system manufacturer.

END OF SECTION 06176

SECTION 06200

FINISH CARPENTRY

PART 1 GENERAL

1.01 SECTION INCLUDES

- A. Finish carpentry items, other than shop prefabricated casework.
- B. Hardware and attachment accessories.

1.02 QUALITY ASSURANCE

- A. Perform work in accordance with AWI Custom.

1.03 DELIVERY, STORAGE, AND HANDLING

- A. Deliver, store, protect, and handle products to site under provisions of the General Requirements.
- B. Protect work from moisture damage.

1.04 FIELD MEASUREMENTS

- A. Verify that field measurements are as indicated on shop drawings and as instructed by the manufacturer.

1.05 COORDINATION

- A. Coordinate the work with plumbing and electrical rough-in, and installation of associated and adjacent components.

PART 2 PRODUCTS

2.01 LUMBER MATERIALS

- A. Softwood Lumber: PS 20; Graded in accordance with AWI Custom; maximum moisture content of 6 percent; suitable for prime and paint.
- B. Hardwood Lumber: Graded in accordance with AWI prime and paint.

2.02 SHEET MATERIALS

- A. Exterior Plywood: Exposed to weather shall be group 1, Exterior type, Grade A-B or A-C as required for exposure.
- B. Interior Plywood: Interior or Exterior type, Group 1 or 2, Grade B-D where concealed, Grade A-C one side exposed and Grade A-A two sides exposed.
- C. Wood Particleboard: ANSI A208.1 Type 1; AWI standard, composed of wood chips, medium density, made with high waterproof resin binders; of grade to suit application; sanded faces.

2.03 FASTENERS

- A. Fasteners: Of size and type to suit application; galvanized finish in concealed locations and brass or chrome finish in exposed locations.

2.04 FABRICATION

- A. Fabricate to AWI Custom standards.
- B. Shop assemble work for delivery to site, permitting passage through building openings.
- C. Fit exposed sheet material edges with 3/8 inch matching hardwood edging. Use one piece for full length only.
- D. When necessary to cut and fit on site, provide materials with ample allowance for cutting. Provide trim for scribing and site cutting.

2.05 SHOP FINISHING

- A. Sand work smooth and set exposed nails and screws.
- B. Apply wood filler in exposed nail and screw indentations.
- C. On items to receive transparent finishes, use wood filler which matches surrounding surfaces and of types recommended for applied finishes.
- D. Seal, stain, and varnish exposed to view surfaces. Brush apply only.
- E. Prime paint. Seal surfaces in contact with cementitious materials.

PART 3 EXECUTION

3.01 EXAMINATION

- A. Verify adequacy of backing and support framing.
- B. Verify mechanical, electrical, and building items affecting work of this section are placed and ready to receive this work.

3.02 INSTALLATION

- A. Install work in accordance with AWI Custom Quality Standard.
- B. Set and secure materials and components in place, plumb, and level.
- C. Carefully scribe work abutting other components, with maximum gaps of 1/32 inch. Do not use additional overlay trim to conceal larger gaps.
- D. Install components trim with nails, screws, bolts with blind fasteners or wall adhesive by gun application.
- E. Install hardware in accordance with manufacturer's instructions.

3.03 SITE APPLIED WOOD TREATMENT

- A. Apply preservative treatment in accordance with manufacturer's instructions.
- B. Brush apply two coats of preservative treatment on wood in contact with cementitious materials, roofing and related metal flashings. Treat site-sawn cuts.
- C. Allow preservative to dry prior to erecting members.

3.04 PREPARATION FOR SITE FINISHING

- A. Site Finishing: Refer to Section 09900.
- B. Before installation, prime paint surfaces of items or assemblies to be in contact with cementitious materials.

3.05 SCHEDULE

- A. Interior:
 - 1. Trim: Primed and painted.
 - 2. Loose Shelving: Melamine finished, color to be selected.
 - 3. Window Sills: Primed and painted.
 - 4. Wood Base: Primed and painted.
 - 5. Wood Light Valance, primed and painted.

END OF SECTION 06200

SECTION 07181

WATER REPELLENT COATING

PART 1 GENERAL

1.01 SECTION INCLUDES

- A. Water repellent coating applied to exterior and interior exposed brick and masonry units' walls.

1.02 SYSTEM DESCRIPTION

- A. Applied coating to Repel moisture absorption in material being treated.

1.03 DELIVERY, STORAGE, AND HANDLING

- A. Deliver, store, protect, and handle products to site.
- B. Protect coating liquid from freezing.

1.04 ENVIRONMENTAL REQUIREMENTS

- A. Do not apply coating when ambient temperature is lower than 50 degrees F or higher than 100 degrees F.

PART 2 PRODUCTS

2.01 MANUFACTURERS

- A. HYDROZO - Clear Double 7.
- B. Substitutions: Under provisions of the General Requirements.

2.02 MATERIALS

- A. Coating: Silane; containing 12 percent minimum solids.

PART 3 EXECUTION

3.01 EXAMINATION

- A. Verify joint sealants are installed and cured.
- B. Verify surfaces to be coated are dry, clean, and free of efflorescence, oil, or other matter detrimental to application of coating.

3.02 PREPARATION

- A. Delay work until masonry mortar concrete substrate is cured a minimum of 5 days.
- B. Remove loose particles and foreign matter.
- C. Remove oil or foreign substance with a chemical solvent which will not affect coating.
- D. Scrub and rinse surfaces with water and let dry.

3.03 APPLICATION

- A. Apply coating in accordance with manufacturer's instructions.
- B. Apply at a rate of 80 sq. ft. per gallon by airless spray.
- C. Apply in one continuous, uniform coat.

END OF SECTION 07181

SECTION 07212
BOARD INSULATION

PART 1 GENERAL

1.01 SECTION INCLUDES

- A. Adhesive, sheet vapor and air barrier.
- B. Board insulation foundation perimeter.

1.02 REFERENCES

- A. ANSI/ASTM D2842 - Water Absorption of Rigid Cellular Plastics.
- B. ASTM C578 - Preformed Cellular Polystyrene Thermal Insulation.
- C. ASTM E96 - Test Methods for Water Vapor Transmission of Materials.

1.03 PERFORMANCE REQUIREMENTS

- A. Materials of this Section shall provide continuity of thermal barrier at building enclosure elements.
- B. Materials of this Section shall provide continuity of vapor and air barrier at building enclosure elements.

1.04 SUBMITTALS

- A. Product Data: Provide data on product characteristics, performance criteria, limitations.
- B. Manufacturer's Installation Instructions: Indicate special environmental conditions required for installation, installation techniques.

1.05 ENVIRONMENTAL REQUIREMENTS

- A. Do not install insulation adhesives when temperature or weather conditions are detrimental to successful installation.

PART 2 PRODUCTS

2.01 MANUFACTURERS - INSULATION MATERIALS

- A. Dow Chemical Co. - Styrofoam
- B. Substitutions: Under provisions of the General Requirements.

2.02 ADHESIVES

- A. Adhesive: Type recommended by insulation manufacturer for application.

2.03 ACCESSORIES

- A. Tape: Polyethylene polyester self-adhering type, mesh reinforced, 2 inch wide.

PART 3 EXECUTION

3.01 EXAMINATION

- A. Verify site conditions.
- B. Verify that substrate, adjacent materials, and insulation boards are dry and ready to receive insulation.
- C. Verify substrate surface is flat, free of honeycomb fin irregularities, materials or substances that may impede adhesive bond.

3.02 PROTECTION OF FINISHED WORK

- A. Protect finished Work.
- B. Do not permit Work to be damaged prior to covering insulation.

3.05 SCHEDULE

- A. Perimeter Insulation - Slab on grade: Styrofoam brand insulation, **3 inch thick, (R-15 min.) 36" min. vertical from top of slab, reference drawings. (Must meet 2021 IECC requirements and Energy Star Multi-Family New Construction Program Version 1.1 for Climate Zone 6)**

END OF SECTION 07212

SECTION 07213

BATT & BLOWN-IN INSULATION

PART 1 GENERAL

1.01 SECTION INCLUDES

- A. Faced Batt insulation at exterior stud walls.
- B. Blown-in insulation at the Attic
- C. Batt insulation for filling perimeter window and door shim spaces, crevices in exterior wall and roof.
- D. Non-Faced Sound batt insulation at interior walls, floors
- E. Vapor retarder.

1.02 REFERENCES

- A. ASTM C665 - Mineral Fiber Blanket Thermal Insulation for Light Frame Construction and Manufactured Housing.
- B. ASTM E84 - Test Method for Surface Burning Characteristics of Building Materials.

1.03 SYSTEM DESCRIPTION

- A. Materials of This Section: Provide continuity of thermal barrier at building enclosure with thermal insulating materials in attic and walls.. Overlap insulations to ensure complete thermal envelope at all exterior surfaces.

1.04 COORDINATION

- A. Coordinate the work with all related Sections for installation of vapor retarder and other forms of insulation.

PART 2 PRODUCTS

2.01 MANUFACTURERS - INSULATION MATERIALS

- A. OWENS-CORNING FIBERGLASS Product - thermal batt insulation.
- B. Substitutions: Under provisions of the General Requirements.
- C. **Concealed insulation shall have a flame spread of 25 or less, and a smoke developed rating not to exceed 450, IBC 2021, 720.2**

2.02 MATERIALS

- A. Batt Insulation, Exterior Walls: ASTM C665; preformed glass fiber batts; loose laid and taped, conforming to the following:
 - 1. Thermal Resistance: **R-20 Min. Batt, with R-6 continuous 1.5" insulated panel sheathing**, reference drawings. **IECC 2021, Energy Requirements**
 - 2. Batt Size: 5-1/2"
 - 3. Facing: **Faced**
- B. Blown Insulation, Attic: ASTM C739; Cellulose Fiber or Fiberglass type.
 - 1. Thermal Resistance: **R-60 Min.**
 - 2. Bulk for pneumatic placement
- C. Sound Batt Insulation, Interior Walls/Floors:
 - 1. Thermal Resistance: **R-11 min.**
 - 1. Batt size: 5-1/2" & 3-1/2".
 - 2. Facing: Unfaced.
- D. Tape: Self-adhering type as recommended by the manufacturer, mesh reinforced, 2 inches wide.

PART 3 EXECUTION

3.01 EXAMINATION

- A. Verify site conditions.
- B. Verify that substrate, adjacent materials, and insulation are dry and ready to be installed.

3.02 INSTALLATION

- A. Install insulation and vapor retarder in accordance with manufacturer's instructions.
- B. Trim insulation neatly to fit spaces. Insulate miscellaneous gaps and voids.
- C. Fit insulation tight in spaces and tight to exterior side of mechanical and electrical services within the plane of insulation.
- D. Install with applied vapor retarder membrane facing warm side of building spaces. Lap ends and side flanges of membrane, caulk, or tape.
- E. Tape seal butt ends, lapped flanges, and tears or cuts in membrane.
- F. Place loose-fill insulation into spaces and onto surfaces as shown, either by pouring or by machine blowing to comply with ASTM C 1015. Level horizontal applications to uniform thickness as indicated, lightly settle to uniform density, but do not compact excessively.
 - 1. For cellulosic loose-fill insulation, comply with the Cellulose Insulation Manufacturers Association's Special Report #3, "Standard Practice for Installing Cellulose Insulation."

END OF SECTION 07213

SECTION 07311

ASPHALT SHINGLES

PART 1 - GENERAL

1.1 RELATED DOCUMENTS

- A. Drawings and general provisions of the Contract, including General and Supplementary Conditions and Division 1 Specification Sections, apply to this Section.

1.2 SUMMARY

- A. This Section includes the following:
 - 1. Asphalt shingles.
 - 2. Felt underlayment.
 - 3. Self-adhering sheet underlayment.
 - 4. Ridge vents.

1.3 DEFINITIONS

- A. Roofing Terminology: Refer to ASTM D 1079 and glossary of NRCA's "The NRCA Roofing and Waterproofing Manual" for definitions of terms related to roofing work in this Section.

1.4 SUBMITTALS

- A. Product Data: For each type of product indicated.
- B. Samples for Initial Selection: For each type of asphalt shingle, ridge and hip cap shingles, ridge vent and exposed valley lining indicated.
 - 1. Include similar Samples of trim and accessories involving color selection.
- C. Samples for Verification: For the following products, of sizes indicated, to verify color selected.
 - 1. Asphalt Shingle: Full-size asphalt shingle strip.
 - 2. Ridge and Hip Cap Shingles: Full-size ridge and hip cap asphalt shingle.
 - 3. Ridge Vent: 12-inch- (300-mm-) long Sample.
 - 4. Exposed Valley Lining: 12 inches (300 mm) square.
 - 5. Self-Adhering Underlayment: 12 inches (300 mm) square.
- D. Qualification Data: For Installer, including certificate signed by asphalt shingle manufacturer stating that Installer is approved, authorized, or licensed to install roofing system indicated.
- E. Product Test Reports: Based on evaluation of comprehensive tests performed by a qualified testing agency or by manufacturer and witnessed by a qualified testing agency, for asphalt shingles.
- F. Research/Evaluation Reports: For asphalt shingles.
- G. Maintenance Data: For asphalt shingles to include in maintenance manuals.
- H. Warranties: Special warranties specified in this Section.

1.5 QUALITY ASSURANCE

- A. Installer Qualifications: A firm or individual that is approved, authorized, or licensed by asphalt shingle roofing system manufacturer to install roofing system indicated.
- B. Source Limitations: Obtain ridge and hip cap shingles ridge vents, felt underlayment, and self-adhering sheet underlayment through one source from a single asphalt shingle manufacturer.
- C. Fire-Test-Response Characteristics: Provide asphalt shingle and related roofing materials with the fire-test-response characteristics indicated, as determined by testing identical products per test method below by UL or another testing and inspecting agency acceptable to authorities having jurisdiction. Identify materials with appropriate markings of applicable testing and inspecting agency.
 - 1. Exterior Fire-Test Exposure: **Class B or better**; ASTM E 108 or UL 790, for application and roof slopes indicated.

1.6 DELIVERY, STORAGE, AND HANDLING

- A. Store roofing materials in a dry, well-ventilated, weathertight location according to asphalt shingle manufacturer's written instructions. Store underlayment rolls on end on pallets or other raised surfaces. Do not double-stack rolls.
 - 1. Handle, store, and place roofing materials in a manner to avoid significant or permanent damage to roof deck or structural supporting members.
- B. Protect unused underlayment from weather, sunlight, and moisture when left overnight or when roofing work is not in progress.

1.7 PROJECT CONDITIONS

- A. Weather Limitations: Proceed with installation only when existing and forecasted weather conditions permit asphalt shingle roofing to be performed according to manufacturer's written instructions and warranty requirements.
1. Install self-adhering sheet underlayment within the range of ambient and substrate temperatures recommended by manufacturer.

1.8 WARRANTY

- A. Special Project Warranty: Roofing Installer's warranty, on warranty form at end of this Section, signed by roofing Installer, covering Work of this Section, in which roofing Installer agrees to repair or replace components of asphalt shingle roofing that fail in materials or workmanship within the following warranty period:
1. Installation Warranty Period: Two years from date of Substantial Completion.
 2. Product Warranty Period: Forty year product warranty.

1.9 EXTRA MATERIALS

- A. Furnish extra materials described below that match products installed and that are packaged with protective covering for storage and identified with labels describing contents.
1. Asphalt Shingles: 100 sq. ft (9.3 sq. m) of each type, in unbroken bundles.

PART 2 - PRODUCTS

2.1 MANUFACTURERS

- A. In other Part 2 articles where titles below introduce lists, the following requirements apply to product selection:
1. Available Products: Subject to compliance with requirements, products that may be incorporated into the Work include, but are not limited to, products specified.
 2. Products: Subject to compliance with requirements, provide one of the products specified.
 3. Products and Installation; **Roof System and Materials to be provided and installed to be Exterior Fire-Test Exposure Class B or better; ASTM E 108 or UL 790.**

2.2 GLASS-FIBER-REINFORCED ASPHALT SHINGLES

- A. Laminated-Strip Asphalt Shingles: **Class A, ASTM D 3462**, laminated, multi-ply overlay construction, glass-fiber reinforced, mineral-granule surfaced, and self-sealing. **GAF – Timberline NS (Natural Shadow) or approved equal, Minimum 30 year Material Warranty.**

1. **Color: Weathered Wood**
2. Butt Edge: Straight or Notched cut.
3. Strip Size: Manufacturer's standard.
4. Algae Resistance: Granules treated to resist algae discoloration.
5. Color and Blends As selected by Architect from manufacturer's full range.

- B. Hip and Ridge Shingles: Manufacturer's standard units to match asphalt shingles.

2.3 UNDERLAYMENT MATERIALS

- A. Felts: ASTM D 4869, Type I, asphalt-saturated organic felts, non-perforated.
- B. Self-Adhering Sheet Underlayment, Granular Surfaced: ASTM D 1970, minimum of 55-mil- thick sheet; glass-fiber-mat-reinforced, SBS-modified asphalt; mineral-granule surfaced; with release paper backing; cold applied.

2.4 RIDGE VENTS

- A. Rigid Ridge Vent: Manufacturer's standard rigid section high-density polypropylene or other UV-stabilized plastic ridge vent with nonwoven geotextile filter strips and with external deflector baffles; for use under ridge shingles.

2.5 ACCESSORIES

- A. Asphalt Roofing Cement: ASTM D 4586, Type II, asbestos free.
- B. Roofing Nails: ASTM F 1667; aluminum, stainless-steel, copper, or hot-dip galvanized steel wire shingle nails, minimum 0.120-inch- (3-mm-) diameter, barbed shank, sharp-pointed, with a minimum 3/8-inch- (9.5-mm-) diameter flat head and of sufficient length to penetrate 3/4 inch (19 mm) into solid wood decking or extend at least 1/8 inch (3 mm) through OSB or plywood sheathing.
1. Where nails are in contact with metal flashing, use nails made from same metal as flashing.
- C. Felt Underlayment Nails: Aluminum, stainless-steel, or hot-dip galvanized steel wire with low profile capped heads or disc caps, 1-inch (25-mm) minimum diameter.

2.6 METAL FLASHING AND TRIM

- A. Sheet Metal Flashing and Trim: Comply with requirements in Division 7 Section "Sheet Metal Flashing and Trim."
 - 1. Sheet Metal: Zinc-coated (galvanized) steel or Prepainted, metallic-coated steel.
- B. Fabricate sheet metal flashing and trim to comply with recommendations in SMACNA's "Architectural Sheet Metal Manual" that apply to design, dimensions, metal, and other characteristics of item.
 - 1. Apron Flashings: Fabricate with lower flange a minimum of 4 inches (100 mm) over and 4 inches (100 mm) beyond each side of down slope asphalt shingles and 6 inches (150 mm)] up the vertical surface.
 - 2. Step Flashings: Fabricate with a headlap of 2 inches (50 mm) and a minimum extension of 4 inches (100 mm) over the underlying asphalt shingle and up the vertical surface.
 - 3. Cricket Flashings: Fabricate with concealed flange extending a minimum of 18 inches (450 mm) beneath upslope asphalt shingles and 6 inches (150 mm) beyond each side of chimney, skylight and 6 inches (150 mm) above the roof plane.
 - 4. Open Valley Flashings: Fabricate in lengths not exceeding 10 feet (3 m) with 1-inch- (25-mm-) high inverted-V profile at center of valley and equal flange widths of 12 inches (300 mm).
 - 5. Drip Edges: Fabricate in lengths not exceeding 10 feet (3 m) with 2-inch (50-mm) roof deck flange and 1-1/2-inch (38-mm) fascia flange with 3/8-inch (9.6-mm) drip at lower edge.
- C. Vent Pipe Flashings: ASTM B 749, Type L51121, at least 1/16 inch (1.6 mm) thick. Provide lead sleeve sized to slip over and turn down into pipe, soldered to skirt at slope of roof and extending at least 4 inches (100 mm) from pipe onto roof.

PART 3 - EXECUTION

3.1 EXAMINATION

- A. Examine substrates, areas, and conditions, with Installer present, for compliance with requirements for installation tolerances and other conditions affecting performance of work.
 - 1. Examine roof sheathing to verify that sheathing joints are supported by framing and blocking or metal clips and that installation is within flatness tolerances.
 - 2. Verify that substrate is sound, dry, smooth, clean, sloped for drainage, and completely anchored; and that provision has been made for flashings and penetrations through asphalt shingles.
 - 3. For the record, prepare written report, endorsed by Installer, listing conditions detrimental to performance of work.
- B. Proceed with installation only after unsatisfactory conditions have been corrected.

3.2 UNDERLAYMENT INSTALLATION

- A. Double-Layer Felt Underlayment: Install double layers of felt underlayment on roof deck perpendicular to roof slope in parallel courses. Install a 19-inch- (485-mm-) wide starter course at eaves and completely cover with full-width second course. Install succeeding courses lapping previous courses 19 inches (485 mm) in shingle fashion. Lap ends a minimum of 6 inches (150 mm). Stagger end laps between succeeding courses at least 72 inches (1830 mm). Fasten with felt underlayment roofing nails.
 - 1. Apply a continuous layer of asphalt roofing cement over starter course and on felt underlayment surface to be concealed by succeeding courses as each felt course is installed.
 - 2. Install felt underlayment on roof sheathing not covered by self-adhering sheet underlayment. Lap edges over self-adhering sheet underlayment not less than 3 inches (75 mm) in direction to shed water.
 - 3. Terminate felt underlayment extended up not less than 4 inches (100 mm)] against sidewalls, curbs, chimneys and other roof projections.
- B. Self-Adhering Sheet Underlayment: Install self-adhering sheet underlayment, wrinkle free, on roof deck. Comply with low-temperature installation restrictions of underlayment manufacturer if applicable. Install at locations indicated below, lapped in direction to shed water. Lap sides not less than 3-1/2 inches (89 mm). Lap ends not less than 6 inches (150 mm) staggered 24 inches (600 mm) between courses. Roll laps with roller. Cover underlayment within seven days.
 - 1. Prime concrete and masonry surfaces to receive self-adhering sheet underlayment.
 - 2. Eaves: Extend from edges of eaves 24 inches (600 mm) beyond interior face of exterior wall. Rakes: Extend from edges of rake 24 inches (600 mm) beyond interior face of exterior wall. Valleys: Extend from lowest to highest point 18 inches (450 mm) on each side. Hips: Extend 18 inches (450 mm) on each side. Ridges: Extend 36 inches (914 mm) on each side without obstructing continuous ridge vent slot.
 - 3. Sidewalls: Extend beyond sidewall 18 inches (450 mm) and return vertically against sidewall not less than 4 inches (100 mm).

4. Dormers, Chimneys, Skylights, and other Roof-Penetrating Elements: Extend beyond penetrating element 18 inches (450 mm) and return vertically against penetrating element not less than 4 inches (100 mm).
 5. Roof Slope Transitions: Extend 18 inches (450 mm) on each roof slope.
- C. Metal-Flashed Open Valley Underlayment: Install two layers of 36-inch- (914-mm-) wide felt underlayment centered in valley. Stagger end laps between layers at least 72 inches (1830 mm). Lap ends of each layer at least 12 inches (300 mm) in direction to shed water, and seal with asphalt roofing cement. Fasten each layer to roof deck with felt underlayment roofing nails.
1. Lap roof deck felt underlayment over first layer of valley felt underlayment at least 6 inches (150 mm).
- 3.3 METAL FLASHING INSTALLATION
- A. General: Install metal flashings and other sheet metal to comply with requirements in Division 7 Section "Sheet Metal Flashing and Trim."
1. Install metal flashings according to recommendations in ARMA's "Residential Asphalt Roofing Manual" and asphalt shingle recommendations in NRCA's "The NRCA Roofing and Waterproofing Manual."
- B. Apron Flashings: Extend lower flange over and beyond each side of downslope asphalt shingles and up the vertical surface.
- C. Step Flashings: Install with a head lap of 2 inches (50 mm) and extend over the underlying asphalt shingle and up the vertical surface. Fasten to roof deck only.
- D. Cricket or Backer Flashings: Install against the roof-penetrating element extending concealed flange beneath upslope asphalt shingles and beyond each side.
- E. Open Valley Flashings: Install centrally in valleys, lapping ends at least 8 inches (200 mm) in direction to shed water. Fasten upper end of each length to roof deck beneath overlap.
1. Secure hemmed flange edges into metal cleats spaced 12 inches apart and fastened to roof deck.
 2. Adhere 9-inch- (225-mm-) wide strip of self-adhering sheet to metal flanges and to self-adhering sheet underlayment.
- F. Rake Drip Edges: Install rake drip edge flashings over underlayment and fasten to roof deck.
- G. Eave Drip Edges: Install eave drip edge flashings below underlayment and fasten to roof sheathing.
- H. Pipe Flashings: Form flashing around pipe penetrations and asphalt shingles. Fasten and seal to asphalt shingles as recommended by manufacturer.
- 3.4 ASPHALT SHINGLE INSTALLATION
- A. Install asphalt shingles according to manufacturer's written instructions, recommendations in ARMA's "Residential Asphalt Roofing Manual," and asphalt shingle recommendations in NRCA's "The NRCA Roofing and Waterproofing Manual."
- B. Install starter strip along lowest roof edge, consisting of an asphalt shingle strip with tabs removed with self-sealing strip face up at roof edge.
1. Extend asphalt shingles 1/2 inch (13 mm) over fascia at eaves and rakes.
 2. Install starter strip along rake edge.
- C. Install first and remaining courses of asphalt shingles stair-stepping diagonally across roof deck with manufacturer's recommended offset pattern at succeeding courses, maintaining uniform exposure.
- D. Install first and remaining courses of asphalt shingles stair-stepping diagonally across roof deck with manufacturer's recommended offset pattern at succeeding courses, maintaining uniform exposure.
- E. Install asphalt shingles by single-strip column or racking method, maintaining uniform exposure. Install full length first course followed by cut second course, repeating alternating pattern in succeeding courses.
- F. Fasten asphalt shingle strips with a minimum of six roofing nails located according to manufacturer's written instructions.
1. Where roof slope exceeds 20:12, seal asphalt shingles with asphalt roofing cement spots.
 2. Where roof slope is less than 4:12, seal asphalt shingles with asphalt roofing cement spots.
 3. When ambient temperature during installation is below 50 deg F (10 deg C), seal asphalt shingles with asphalt roofing cement spots.
- G. Open Valleys: Cut and fit asphalt shingles at open valleys, trimming upper concealed corners of shingle strips. Maintain uniform width of exposed open valley from highest to lowest point.
1. Set valley edge of asphalt shingles in a 3-inch- (75-mm-) wide bed of asphalt roofing cement.
 2. Do not nail asphalt shingles to metal open valley flashings.
- H. Ridge Vents: Install continuous ridge vents over asphalt shingles according to manufacturer's written instructions. Fasten with roofing nails of sufficient length to penetrate sheathing.
- I. Ridge and Hip Cap Shingles: Maintain same exposure of cap shingles as roofing shingle exposure. Lap cap shingles at ridges to shed water away from direction of prevailing winds. Fasten with roofing nails of sufficient length to penetrate sheathing.

END OF SECTION 07311

SECTION 07460

SIDING

PART 1 - GENERAL

1.1 RELATED DOCUMENTS

- A. Drawings and general provisions of the Contract, including General and Supplementary Conditions and Division 1 Specification Sections, apply to this Section.

1.2 SUMMARY

- A. This Section includes the following:
 1. Siding: Board and Batten; Lap Siding
 2. Soffits
 3. Trim & decorative accessories

1.3 SUBMITTALS

- A. Product Data: For each type of product indicated.
- B. Samples for Initial Selection: For siding, soffit, and decorative accessories.

1.4 QUALITY ASSURANCE

- A. Source Limitations for Siding and Soffit: Obtain [each type, color, texture, and pattern of] siding and soffit, including related accessories, through one source from a single manufacturer.
- B. Vinyl Siding Certification Program: Provide vinyl siding products that are listed in VSI's list of certified products.

1.5 DELIVERY, STORAGE, AND HANDLING

- A. Store materials in a dry, well-ventilated, weathertight place.

1.6 PROJECT CONDITIONS

- A. Weather Limitations: Proceed with siding installation only if substrate is completely dry and if existing and forecasted weather conditions permit siding to be installed according to manufacturer's written instructions.

1.7 SEQUENCING

- A. Coordinate installation with flashings and other adjoining construction to ensure proper sequencing.

1.8 WARRANTY

- A. Special Warranty: Manufacturer's standard form in which manufacturer agrees to repair or replace siding that does not comply with requirements or that fails within specified warranty period. Failures include, but are not limited to, cracking, deforming, fading, or otherwise deteriorating beyond normal weathering.
 1. Warranty Period: 5 years from date of Substantial Completion.

1.9 EXTRA MATERIALS

- A. Furnish extra materials described below that match products installed and that are packaged with protective covering for storage and identified with labels describing contents.
 1. Furnish full lengths of siding and trim in a quantity equal to 2 percent of amount installed.

PART 2 - PRODUCTS

2.1 MANUFACTURERS

- A. In other Part 2 articles where titles below introduce lists, the following requirements apply to product selection:
 1. Available Products: Subject to compliance with requirements, products that may be incorporated into the Work include, but are not limited to, products specified.
 2. Products: Subject to compliance with requirements, provide one of the products specified.

3. Available Manufacturers: Subject to compliance with requirements, manufacturers offering products that may be incorporated into the Work include, but are not limited to, manufacturers specified.
4. Manufacturers: **James Hardie**, Subject to compliance with requirements, provide products by one of the manufacturers specified.
5. Basis-of-Design Product: The design for each siding and soffit is based on the product named. Subject to compliance with requirements, provide either the named product or a comparable product by one of the other manufacturers specified.

2.2 SIDING

- A. **Fiber-Cement Siding (Board and Batten):** Hardie Panel (Select Cedarmill, Primed for Paint) & Hardie Trim Batten Boards (Rustic Grain, Primed for Paint) or approved equal, Submit manufacturer's information for approval.
- B. **Fiber-Cement Siding (Lap Siding):** Hardi Plank (Smooth, Primed for Paint) or approved equal, Submit manufacturer's information for approval.

2.3 SOFFIT

- A. **Fiber-Cement Soffit or Vinyl Soffit:** Hardi Soffit (Vented Smooth, Primed for Paint) or approved equal, Submit manufacturer's information for approval.

2.4 ACCESSORIES

- A. Siding Accessories: Provide starter strips, edge trim, corner cap, and other items as recommended by siding manufacturer for building configuration.
 1. Provide accessories made from same material as adjacent siding, unless otherwise indicated.
 2. Provide accessories matching color and texture of adjacent siding, unless otherwise indicated.
- B. Decorative Accessories: Provide the following types of decorative accessories as indicated:
 1. Door and window casings.
 2. Entrance and window head pediments.
 3. Fascia.
 4. Moldings and trim.
- C. Flashing: Provide aluminum flashing complying with Division 7 Section "Sheet Metal Flashing and Trim" at window and door heads and where indicated.
- D. Elastomeric Joint Sealant: joint sealant complying with requirements in Division 7 Section "Joint Sealants" for Use NT (nontraffic) and for Uses M, G, A, and, as applicable to joint substrates indicated, O joint substrates.
- E. Fasteners:
 1. For fastening to wood, use siding nails of sufficient length to penetrate a minimum of 1 inch (25 mm) into substrate.
 2. For fastening to metal, use ribbed bugle-head screws of sufficient length to penetrate a minimum of 1/4 inch (6 mm) or 3 screw-threads into substrate.
 3. For fastening aluminum, use aluminum fasteners. Where fasteners will be exposed to view, use prefinished aluminum fasteners in color to match item being fastened.
 4. For fastening fiber-cement siding, use hot-dip galvanized fasteners.

PART 3 - EXECUTION

3.1 EXAMINATION

- A. Examine substrates for compliance with requirements for installation tolerances and other conditions affecting performance of siding. Proceed with installation only after unsatisfactory conditions have been corrected.

3.2 PREPARATION

- A. Clean substrates of projections and substances detrimental to application.

3.3 INSTALLATION

- A. General: Comply with siding manufacturer's written installation instructions applicable to products and applications indicated unless more stringent requirements apply. Center nails in elongated nailing slots without binding siding to allow for thermal movement. Overlap joints to shed water away from direction of prevailing wind.

- B. Isolate dissimilar metals by separating with rubber gaskets or elastomeric sealant. Use rubber washers where fasteners made from dissimilar metal penetrate siding. Isolate dissimilar metals behind siding by covering with polyethylene film.

3.4 ADJUSTING AND CLEANING

- A. Remove damaged, improperly installed, or otherwise defective siding materials and replace with new materials complying with specified requirements.
- B. Clean finished surfaces according to siding manufacturer's written instructions and maintain in a clean condition during construction.

END OF SECTION 07460

SECTION 07620

SHEET METAL FLASHING AND TRIM

PART 1 GENERAL

1.01 SECTION INCLUDES

- A. Cap and sill flashings.
- B. Gutters and down spouts.
- C. Counterflashings at roof mounted equipment and vent stacks.
- D. Fascias.
- E. Miscellaneous flashings and closure pieces.

1.02 SUBMITTALS

- A. Shop Drawings: Indicate material profile, jointing pattern, jointing details, fastening methods, flashings, terminations, and installation details.

1.03 QUALITY ASSURANCE

- A. Perform work in accordance with SMACNA standard details and requirements.

1.04 QUALIFICATIONS

- A. Fabricator and Installer: Company specializing in sheet metal flashing work with three years documented experience.

1.05 DELIVERY, STORAGE, AND HANDLING

- A. Deliver, store, protect, and handle products to site under provisions of the General Requirements.
- B. Stack preformed and prefinished material to prevent twisting, bending, or abrasion, and to provide ventilation. Slope metal sheets to ensure drainage.
- C. Prevent contact with materials which may cause discoloration or staining.

PART 2 PRODUCTS

2.01 SHEET MATERIALS

- A. Pre-Coated Galvanized Steel: ASTM A446, Grade A, G90 zinc coating; 24 gage core steel, exposed flashings shall be shop prefinished with KYNAR coating of color as selected.

2.02 ACCESSORIES

- A. Fasteners: Galvanized steel with soft neoprene washers.
- B. Underlayment: ASTM D2178, No. 30 asphalt saturated roofing felt.
- C. Slip Sheet: Rosin sized building paper.
- D. Primer: Zinc chromate type.
- E. Sealant: Polyurethane type, specified in Section 07900.
- F. Bedding Compound: Rubber-asphalt type.
- G. Plastic Cement: ASTM D4586, Type II.
- H. Reglets: Recessed type, galvanized steel; face and ends covered with plastic tape.
- I. Gutter and Downspout Anchorage Devices: SMACNA requirements. Type recommended by fabricator.

2.03 COMPONENTS

- A. Gutters: Size and shape per drawings.
- B. Downspouts: Rectangular profile.
- C. Accessories: Profiled to suit gutters and downspouts.
- D. Downspout Boots: Flexible plastic or metal.

2.04 FABRICATION

- A. Form sections true to shape, accurate in size, square, and free from distortion or defects.
- B. Fabricate cleats of metal, same material as sheet, interlockable with sheet.
- C. Form pieces in longest possible lengths. Hem exposed edges on underside 1/2 inch; miter and seam corners.

- D. Form material with flat lock seams.
- E. Fabricate corners from one piece with minimum 18 inch long legs; seam and/or solder for rigidity, seal with sealant.
- F. Fabricate vertical faces with bottom edge formed outward 1/4 inch and hemmed to form drip.
- G. Fabricate flashings to allow toe to extend 2 inches over roofing. Return and brake edges.

2.05 FINISH

- A. Exposed metal shall pre-finished with Kynar finish color to be selected.

PART 3 EXECUTION

3.01 EXAMINATION

- A. Verify roof openings, curbs, pipes, sleeves, ducts, or vents through roof are solidly set, reglets in place, and nailing strips located.
- B. Verify roofing termination and base flashings are in place, sealed, and secure.

3.02 PREPARATION

- A. Install starter and edge strips, and cleats before starting installation.
- B. Install surface mounted reglets true to lines and levels. Seal top of reglets with sealant.

3.03 INSTALLATION

- A. Conform to drawing details included in the SMACNA manual unless otherwise indicated on the drawings.
- B. Insert flashings into reglets to form tight fit. Secure in place with lead wedges. Pack remaining spaces with lead wool. Seal flashings into reglets with sealant.
- C. Apply plastic cement compound between metal flashings and felt flashings.
- D. Fit flashings tight in place. Make corners square, surfaces true and straight in planes, and lines accurate to profiles.
- E. Seal metal joints watertight. Secure gutters and downspouts in place using fasteners. Set splash pans under downspouts. Seal metal joints watertight.

END OF SECTION 07620

SECTION 07900

JOINT SEALERS

PART 1 GENERAL

1.01 SECTION INCLUDES

- A. Preparing substrate surfaces.
- B. Sealant and joint backing.

1.02 QUALITY ASSURANCE

- A. Perform work in accordance with sealant manufacturer's requirements for preparation of surfaces and material installation instructions.
- B. Perform acoustical sealant application work in accordance with ASTM C919.

1.03 QUALIFICATIONS

- A. Manufacturer: Company specializing in manufacturing the Products specified in this section with minimum three years documented experience.
- B. Applicator: Company specializing in performing the work of this section with minimum years documented experience.

1.04 WARRANTY

- A. Provide five year warranty.
- B. Warranty: Include coverage for installed sealants and accessories which fail to achieve air tight seal, water tight seal, and exhibit loss of adhesion or cohesion, or do not cure.

PART 2 PRODUCTS

2.01 SEALANTS

- A. Acrylic Latex (Interior Minor Movement): ASTM C920, Single component, non-staining, non-bleeding, non-sagging; white color paintable; manufactured by Pecora AC 20 + silicone.
- B. Butyl Sealant (Interior Minor Movement): ASTM C920 single component, solvent release, non-skinning, non-sagging, white, paintable; manufactured by Pecora BC 158.
- C. Silicone Sealant (Exterior, Interior Major Movement and Water Resistant Areas): Single component, solvent curing, non-sagging, non-staining, fungus resistant, non-bleeding; color as selected or to match adjacent materials; manufactured by Pecora 895 silicone.
- D. Bituminous Based (Paving): Single component, asphalt compound, elongation capability of 0 to 2 percent of joint width.

2.02 ACCESSORIES

- A. Primer: Non-staining type, recommended by sealant manufacturer to suit application.
- B. Joint Cleaner: Non-corrosive and non-staining type, recommended by sealant manufacturer; compatible with joint forming materials.
- C. Joint Backing: ASTM D1056; round, closed or open cell polyethylene foam rod; oversized 30 to 50 percent larger than joint width.
- D. Bond Breaker: Pressure sensitive tape recommended by sealant manufacturer to suit application.

PART 3 EXECUTION

3.01 EXAMINATION

- A. Verify that substrate surfaces and joint openings are ready to receive work.
- B. Verify that joint backing and release tapes are compatible with sealant.

3.02 PREPARATION

- A. Remove loose materials and foreign matter which might impair adhesion of sealant.
- B. Clean and prime joints in accordance with manufacturer's instructions.
- C. Perform preparation in accordance with manufacturer's instructions.
- D. Protect elements surrounding the work of this section from damage or disfiguration.

3.03 INSTALLATION

- A. Install sealant in accordance with manufacturer's instructions.
- B. Measure joint dimensions and size materials to achieve required 2:1 width/depth ratios.
- C. Install joint backing to achieve a neck dimension no greater than 1/3 of the joint width.
- D. Install bond breaker where joint backing is not used.
- E. Install sealant free of air pockets, foreign embedded matter, ridges, and sags.
- F. Apply sealant within recommended application temperature ranges. Consult manufacturer when sealant cannot be applied within these temperature ranges.

3.04 SCHEDULE

- A. Interior: Caulk around all frames, windows, doors, openings, trim, etc., as required to seal or fill gaps, cracks, to make material transitions watertight and/or visually tight and finished.
- B. Exterior: Caulk around all frames, windows, doors, openings, trim, material transitions etc., as required to seal or fill gaps, cracks, to make material transitions watertight and/or visually tight finished.
- C. Paving: Caulk as required to seal or fill gaps, expansion joints, and cracks to make transitions watertight and/or visually tight.

END OF SECTION 07900

SECTION 08111

STANDARD DOORS AND FRAMES

PART 1 GENERAL

1.01 SECTION INCLUDES

- A. Exterior Entry Doors: **Fire-rated (20 min) and thermally insulated, thermally Broken, Masonite HD Wood Edge panel doors with Fiberglass facing and metal frames.** OR approved equal

1.02 REFERENCES

- A. ANSI A117.1 - Specifications for Making Buildings and Facilities Accessible to and Usable by Physically Handicapped People.
- B. NFPA 80 - Fire Doors and Windows.
- C. NFPA 252 - Fire Tests for Door Assemblies.
- D. UL 10B - Fire Tests of Door Assemblies.

1.03 DELIVERY, STORAGE, AND HANDLING

- A. Deliver, store, protect, and handle products to site.
- B. Accept doors and frames on site in manufacturer's packaging. Inspect for damage.

1.04 FIELD MEASUREMENTS

- A. Verify that field measurements are as indicated on shop drawings.

PART 2 PRODUCTS

2.01 DOOR MANUFACTURERS

- A. **Masonite Int. Corp.,**
- B. Substitutions: Under provisions of the General Requirements.

2.02 DOORS

- A. Exterior Insulated Doors, **Fiberglass Oakcraft 2 Panel, Wood-Grain, Thermally Broken: SDI-100 Grade III.** Thermo-pane insulated windows as where indicated. Or approved equal.

2.03 DOOR CONSTRUCTION

- A. Exterior Face: Fiberglass facing, .0215" min. with protective chemical coatings and primer.
- B. Core: Polyurethane or styrene foam.
- C. **Thermal Insulated Door, Masonite, Per Energy Star Multi-Family New Construction Program Version 1.1 (Climate Zone 6 – Albany County, Wyoming)** OR approved equal which meets the 2024 Wyoming QAP, 2021 IECC and the Energy Star Multi-Family New Construction Version 1.1
 - 1. U-Factor Mins: 0.17 (Opaque), 0.25 (1/2 lite or less), 0.30 (greater than 1/2 lite)
 - 2. SHGC Mins: Any (Opaque), 0.25 (1/2 lite of less), 0.40 (greater than 1/2 lite)

2.04 FRAMES

- A. Exterior Frames: 16 gage thick material, base metal thickness.
- B. **Frame Color: Dark Bronze**

2.05 ACCESSORIES

- A. Removable Stops: Rolled steel channel shape, mitered corners; prepared for countersink style screws.
- B. Primer: Manufacturers standard.
- C. Silencers: Resilient rubber, fitted into drilled hole.

2.06 FABRICATION

- A. Fabricate doors with hardware reinforcement welded in place.
- B. Attach fire rated label to each door unit.
- C. Close top and bottom edge of exterior doors with flush end closure. Seal joints watertight.
- D. Configure exterior doors with special profile to receive recessed weatherstripping.
- E. Wood frames to be tight and solid, with insulation at all voids and cavities.
- F. Transom Bars for Glazed Lights: Fixed type, of same profiles as jamb and head.
- G. Prepare frame for silencers. Provide three single silencers for single doors and mullions of double doors on strike side. Provide two single silencers on frame head at double doors without mullions.
- H. Configure exterior frames with special profile to receive recessed weathersripping.
- I. Fabricate frames to suit masonry wall coursing with 4 or 2 inch head member.

- 2.07 FINISH
 - A. Fiberglass Reinforced facings, chemically coated and primed.
 - B. Primer: Baked.
 - C. Coat inside of frame profile with bituminous coating to a thickness of 1/16 inch.

PART 3 EXECUTION

- 3.01 EXAMINATION
 - A. Verify that opening sizes and tolerances are acceptable.
- 3.02 INSTALLATION
 - A. Install doors and frames in accordance with ANSI/SDI-100 and DHI.
 - B. Coordinate installation of glass and glazing.
 - C. Install door louvers, plumb, and level. Pack insulation in all voids and cavities to ensure weather tight.
 - D. Coordinate installation of doors and frames with **installation of storm door frames and hardware**.
 - E. Coordinate with masonry and wallboard wall construction for anchor placement.
 - F. Install roll-formed steel reinforcement channels between two abutting frames. Anchor to structure and floor.
- 3.03 ERECTION TOLERANCES
 - A. Maximum Diagonal Distortion: 1/16 inch measured with straight edge, corner to corner.
- 3.04 ADJUSTING
 - A. Adjust door for smooth and balanced door movement.

END OF SECTION 08111

SECTION 08211

FLUSH WOOD DOORS

PART 1 GENERAL

1.01 SECTION INCLUDES

- A. Flush wood doors; flush and flush glazed configuration; fire rated and non-rated.

1.02 SUBMITTALS

- A. Shop Drawings: Illustrate door opening criteria, elevations, sizes, types, swings, undercuts required, special beveling, special blocking for hardware, identify cutouts for glazing, and louvers.
- B. Product Data: Indicate door core materials and construction; veneer species, type and characteristics; factory machining criteria, and factory finishing criteria.
- C. Manufacturer's Installation Instructions: Indicate special installation instructions.

1.03 QUALITY ASSURANCE

- A. Perform work in accordance with AWI Quality Standard Section 1300, Custom Grade.
- B. Finish doors in accordance with AWI Quality Standard, grades identified in schedule.

1.04 QUALIFICATIONS

- A. Manufacturer: Company specializing in manufacturing the Products specified in this section with minimum three years documented experience.

1.05 REGULATORY REQUIREMENTS

- A. Fire Door Construction: Conform to NFPA 252, UL 10B.
- B. Installed Fire Rated Door Assembly: Conform to NFPA 80 for fire rated class as scheduled.

1.06 DELIVERY, STORAGE, AND HANDLING

- A. Deliver, store, protect, and handle products to site
- B. Accept doors on site in manufacturer's packaging. Inspect for damage. Do not store in damp or wet areas; or in areas where sunlight might bleach veneer. Seal top and bottom edges if stored more than one week. Break seal on-site to permit ventilation.

1.07 FIELD MEASUREMENTS

- A. Verify that field measurements are as indicated on shop drawings.

1.08 COORDINATION

- A. Coordinate the work with door opening construction, door frame and door hardware installation.

1.09 WARRANTY

- A. Provide warranty to the following term:
 - 1. Exterior Doors: 5 years.
 - 2. Interior Doors: Life of original installation.
- B. Include coverage for delamination of veneer, warping beyond specified installation tolerances, defective materials, telegraphing core construction.

PART 2 PRODUCTS

2.01 MANUFACTURERS

- A. Weyerhaeuser.
- B. Substitutions: Under provisions of the General Requirements.

2.02 DOOR TYPES

- A. Flush Interior Doors: 1-3/4 inches thick; solid core construction, fire rated as indicated.

2.03 DOOR CONSTRUCTION

- A. Core (Solid, Non-Rated): AWI Section 1300, Type PC-Particleboard.
- B. Core (Solid, Fire Rated): AWI Section 1300, Type FP or FM rating as required or indicated.

- 2.04 FLUSH DOOR FACING
- A. Veneer Facing (Flush Interior Doors): AWI Custom quality oak species wood, plane sliced, uniform grain, for transparent stain and finish.
- 2.05 ACCESSORIES
- A. Glazing Stops: Wood, of same species as door facing Wood with metal clips for rated doors, mitered corners; prepared for countersink style screws.
- 2.06 FABRICATION
- A. Fabricate non-rated doors in accordance with AWI Quality Standards requirements.
 - B. Fabricate fire rated doors in accordance with AWI Quality Standards and to UL requirements. Attach fire rating label to door.
 - C. Astragals for Fire Rated Double Doors: Steel, T shaped, overlapping and recessed at face edge, specifically for double doors.
 - D. Provide lock blocks at lock edge and top of door for closer hardware reinforcement.
 - E. Vertical Exposed Edge of Stiles: Of same species as veneer facing. Hardwood for transparent finish.
 - F. Fit door edge trim to edge of stiles after applying veneer facing.
 - G. Bond edge banding to cores.
 - H. Factory machine doors for finish hardware in accordance with hardware requirements and dimensions. Do not machine for surface hardware. Provide solid blocking for through bolted hardware.
 - I. Factory pre-fit doors for frame opening dimensions identified on shop drawings.
 - J. Cut and configure exterior door edge to receive recessed weather stripping devices. Provide edge clearances in accordance with AWI 1600.
- 2.07 FINISH
- A. Site finish doors in accordance with AWI Quality Standard Section 1500 to the following finish designations:
 - 1. Finish Doors: Submit stained sample and finished samples for selection. Conversion varnish alkyd-urea, custom quality, sheen. Reference Section 09900.

PART 3 EXECUTION

- 3.01 EXAMINATION
- A. Verify that opening sizes and tolerances are acceptable.
 - B. Do not install doors in frame openings that are not plumb or are out-of-tolerance for size or alignment.
- 3.02 INSTALLATION
- A. Install fire rated and non-rated doors in accordance with AWI Quality Standard, NFPA 80 and to Warnock Hersey requirements.
 - B. Trim non-rated door width by cutting equally on both jamb edges.
 - C. Trim door height by cutting bottom edges to a maximum of 3/4 inch (19 mm). Trim fire door height at bottom edge only, in accordance with fire rating requirements.
 - D. Pilot drill screw and bolt holes. Use threaded through bolts for half surface hinges.
 - E. Machine cut for hardware. Core for handsets and cylinders.
 - F. Coordinate installation of glass and glazing.
- 3.03 INSTALLATION TOLERANCES
- A. Maximum Diagonal Distortion (Warp): 1/8 inch measured with straight edge or taught string, corner to corner, over an imaginary 36 x 84 inch surface area.
 - B. Maximum Vertical Distortion (Bow): 1/8 inch measured with straight edge or taught string, top to bottom, over an imaginary 36 x 84 inch surface area.
 - C. Maximum Width Distortion (Cup): 1/8 inch measured with straight edge or taught string, edge to edge, over an imaginary 36 x 84 inch surface area.
- 3.04 ADJUSTING
- A. Adjust door for smooth and balanced door movement.

END OF SECTION 08211

SECTION 08212

PANEL MASONITE DOORS

PART 1 GENERAL

1.01 SECTION INCLUDES

- A. Masonite Panel doors; Panel Masonite doors as indicated on the drawings; fire rated and non-rated.

1.03 QUALIFICATIONS

- A. Manufacturer: Company specializing in manufacturing the Products specified in this section with minimum three years documented experience.

1.04 DELIVERY, STORAGE, AND HANDLING

- A. Deliver, store, protect, and handle products to site
- B. Accept doors on site in manufacturer's packaging. Inspect for damage. Do not store in damp or wet areas; or in areas where sunlight might bleach veneer. Seal top and bottom edges if stored more than one week. Break seal on-site to permit ventilation.

1.05 FIELD MEASUREMENTS

- A. Verify that field measurements are as indicated on shop drawings.

1.06 COORDINATION

- A. Coordinate the work with door opening construction, door frame and door hardware installation.

1.07 WARRANTY

- A. Provide warranty to the following term:
 - 1. Interior Doors: 1 year
- B. Include coverage for delamination of veneer, warping beyond specified installation tolerances, defective materials, telegraphing core construction.

PART 2 PRODUCTS

2.01 MANUFACTURERS

- A. Masonite Int Corp
- B. Substitutions: Under provisions of the General Requirements.

2.02 DOOR TYPES

- A. Panel Interior Doors: 1-3/4 inches thick

2.03 DOOR CONSTRUCTION

- A. Core (Solid, Non-Rated).
- B. Core (Solid, Fire Rated).

2.04 ACCESSORIES

- A. Glazing Stops: Masonite, of same species as door facing Masonite with metal clips for rated doors, mitered corners; prepared for countersink style screws.

2.05 FABRICATION

- A. Fabricate non-rated doors in accordance with Standard requirements.
- B. Fabricate fire rated doors in accordance with Standards and to UL requirements. Attach fire rating label to door.
- C. Provide lock blocks at lock edge and top of door for closer hardware reinforcement.
- D. Fit door edge trim to edge of stiles after applying veneer facing.
- E. Bond edge banding to cores.
- F. Factory machine doors for finish hardware in accordance with hardware requirements and dimensions. Do not machine for surface hardware. Provide solid blocking for through bolted hardware.
- G. Factory pre-fit doors for frame opening dimensions identified on shop drawings.
- H. Cut and configure exterior door edge to receive recessed weather stripping devices.

PART 3 EXECUTION

3.01 EXAMINATION

- A. Verify that opening sizes and tolerances are acceptable.
- B. Do not install doors in frame openings that are not plumb or are out-of-tolerance for size or alignment.

3.02 INSTALLATION

- A. Install fire rated and non-rated doors in accordance with Standards requirements.
- B. Trim non-rated door width by cutting equally on both jamb edges.
- C. Trim door height by cutting bottom edges to a maximum of 3/4 inch (19 mm). Trim fire door height at bottom edge only, in accordance with fire rating requirements.
- D. Pilot drill screw and bolt holes. Use threaded through bolts for half surface hinges.
- E. Machine cut for hardware. Core for handsets and cylinders.
- F. Coordinate installation of glass and glazing.

3.03 INSTALLATION TOLERANCES

- A. Maximum Diagonal Distortion (Warp): 1/8 inch measured with straight edge or taught string, corner to corner, over an imaginary 36 x 84 inch surface area.
- B. Maximum Vertical Distortion (Bow): 1/8 inch measured with straight edge or taught string, top to bottom, over an imaginary 36 x 84 inch surface area.
- C. Maximum Width Distortion (Cup): 1/8 inch measured with straight edge or taught string, edge to edge, over an imaginary 36 x 84 inch surface area.

3.04 ADJUSTING

- A. Adjust door for smooth and balanced door movement.

END OF SECTION 08212

SECTION 085313

VINYL WINDOWS

PART 1 - GENERAL

1.1 RELATED DOCUMENTS

- A. Drawings and general provisions of the Contract, including General and Supplementary Conditions and Division 01 Specification Sections, apply to this Section.

1.2 SUMMARY

- A. This Section includes fixed and operable vinyl-framed windows.

1.3 PERFORMANCE REQUIREMENTS

- A. General: Provide vinyl windows capable of complying with performance requirements indicated, based on testing manufacturer's windows that are representative of those specified, and that are of test size indicated below:
 - 1. Size required by AAMA/WDMA 101/I.S.2/NAFS
 - 2. Size indicated on Drawings.
- B. Structural Performance: Provide vinyl windows capable of withstanding the effects of the following loads, based on testing units representative of those indicated for Project that pass AAMA/WDMA 101/I.S.2/NAFS, Uniform Load Structural Test:
 - 1. Design Wind Loads: Determine design wind loads applicable to Project from basic wind speed indicated in **miles per hour (meters per second)** at **33 feet (10 m)** above grade, according to ASCE 7, Section 6.5, "Method 2-Analytical Procedure," based on mean roof heights above grade indicated on Drawings.
 - a. Basic Wind Speed: **115 mph, 3 second gusts**
 - b. **Exposure Category: C (Laramie, Wyoming).**
- C. **2021 IECC and Energy Star Multi-Family New Construction Program Version 1.1 – Climate Zone 6 (Albany County, Wyoming).**

1.4 QUALITY ASSURANCE

- A. Installer Qualifications: An installer acceptable to vinyl window manufacturer for installation of units required for this Project.
 - 1. Installer's responsibilities include providing professional engineering services needed to assume engineering responsibility.
 - 2. Engineering Responsibility: Preparation of data for vinyl windows, including Shop Drawings, based on testing and engineering analysis of manufacturer's standard units in assemblies similar to those indicated for this Project.
- B. Manufacturer Qualifications: A manufacturer capable of fabricating vinyl windows that meet or exceed performance requirements indicated and of documenting this performance by inclusion in lists and by labels, test reports, and calculations.
- C. Source Limitations: Obtain vinyl windows through one source from a single manufacturer.

Product Options: Information on Drawings and in Specifications establishes requirements for vinyl windows' aesthetic effects and performance characteristics. Aesthetic effects are indicated by dimensions, arrangements, alignment, and profiles of components and assemblies as they relate to sightlines, to one another, and to adjoining construction. Performance characteristics are indicated by criteria subject to verification by one or more methods including preconstruction testing, field testing, and in-service performance.

1.5 PROJECT CONDITIONS

- A. Field Measurements: Verify vinyl window openings by field measurements before fabrication and indicate measurements on Shop Drawings.

1.6 WARRANTY

- A. When warranties are required, verify with Owner's counsel that special warranties state in this Article are not less than remedies available to Owner under prevailing local laws. Coordinate with Division 01 Section "Product Requirements."
- B. Special Warranty: Manufacturer's standard form in which manufacturer agrees to repair or replace vinyl windows that fail in materials or workmanship within specified warranty period.

1. Failures include, but are not limited to, the following:
 - a. Failure to meet performance requirements.
 - b. Structural failures including excessive deflection, water leakage, air infiltration, or condensation.
 - c. Faulty operation of movable sash and hardware.
 - d. Deterioration of vinyl, other materials, and finishes beyond normal weathering.
 - e. Failure of insulating glass.
2. Warranty Period:
 - a. Window: **Two** years from date of Substantial Completion.
 - b. Glazing: **Five** years from date of Substantial Completion.
 - c. Vinyl Finish: **Five** years from date of Substantial Completion.

PART 2 - PRODUCTS

2.1 MANUFACTURERS

- A. Manufacturer and Product: Pella, Anderson or approved equal subject to compliance with requirements. **2021 IECC and Energy Star Multi-Family New Construction Program Version 1.1 – Climate Zone 6 (Albany County, Wyoming).**
 1. Pella – Encompass by Pella, Single-Hung, Tilt Sash and alternate for fixed, casement and or other window types. **U-Factor Min. = 0.27; SHGC = Any.** Must abide by performance specs within this spec section and submit for approval.
 2. Andersen – Series 100 Windows, Single Hung, Tilt Sash and alternate for fixed, casement, and or other window types. **U-Factor Min. = 0.27; SHGC = Any.** Must abide by performance specs within this spec section and submit for approval.
 3. Frame Color: **Dark Bronze**

2.2 MATERIALS

- A. Vinyl Extrusions: Rigid (un-plasticized) hollow PVC extrusions, formulated and extruded for exterior applications, complying with AAMA/WDMA 101/I.S.2/NAFS.
- B. Vinyl Trim and Glazing Stops: Material and finish to match frame members.
- C. Fasteners: Aluminum, nonmagnetic stainless steel, epoxy adhesive, or other materials warranted by manufacturer to be noncorrosive and compatible with vinyl window members, cladding, trim, hardware, anchors, and other components.
 1. Exposed Fasteners: Unless unavoidable for applying hardware, do not use exposed fasteners. For application of hardware, use fasteners that match finish of member or hardware being fastened, as appropriate.
- D. Anchors, Clips, and Accessories: Aluminum, nonmagnetic stainless steel, or zinc-coated steel or iron complying with ASTM B 633 for SC 3 severe service conditions; provide sufficient strength to withstand design pressure indicated.
- E. Reinforcing Members: Aluminum, or nonmagnetic stainless steel, or nickel/chrome-plated steel complying with ASTM B 456 for Type SC 3 severe service conditions, or zinc-coated steel or iron complying with ASTM B 633 for SC 3 severe service conditions; provide sufficient strength to withstand design pressure indicated.
- F. Compression-Type Weather Stripping: Provide compressible weather stripping designed for permanently resilient sealing under bumper or wiper action, and for complete concealment when vinyl window is closed.
 1. Weather-Stripping Material: Elastomeric cellular preformed gaskets complying with ASTM C 509.
 2. Weather-Stripping Material: Dense elastomeric gaskets complying with ASTM C 864.
 3. Weather-Stripping Material: Manufacturer's standard system and materials complying with AAMA/WDMA 101/I.S.2/NAFS.
- G. Sliding-type weather stripping is primarily for double-hung or horizontal-sliding windows. Delete first paragraph below if these types of units are not included or if full weather stripping is not desired.
- H. Sliding-Type Weather Stripping: Provide woven-pile weather stripping of wool, polypropylene, or nylon pile and resin-impregnated backing fabric. Comply with AAMA 701/702.
 1. Weather Seals: Provide weather stripping with integral barrier fin or fins of semirigid, polypropylene sheet or polypropylene-coated material. Comply with AAMA 701/702.
- I. Replaceable Weather Seals: Comply with AAMA 701/702.

- 2.3 WINDOWS
- A. Window Type: Single hung & fixed as indicated on Drawings.
 - B. AAMA/WDMA Performance Requirements: Provide vinyl windows of performance indicated that comply with AAMA/WDMA 101/I.S.2/NAFS.
 - C. Condensation-Resistance Factor (CRF): Provide vinyl windows tested for thermal performance according to AAMA 1503, showing a CRF of [45] .
 - D. Thermal Transmittance: Provide vinyl windows with a whole-window, U-factor maximum indicated at **15-mph (24-km/h)** exterior wind velocity and winter condition temperatures when tested according to [AAMA 1503]. **2021 IECC and Energy Star Multi-Family New Construction Program Version 1.1 – Climate Zone 6 (Albany County, Wyoming)**
- 2.4 GLAZING
- A. Glass and Glazing Materials: Refer to Division 08 Section "Glazing" for glass units and glazing requirements applicable to glazed vinyl window units.
 - B. Glass: Clear, insulating-glass units.
- 2.5 HARDWARE
- A. General: Provide manufacturer's standard hardware fabricated from aluminum, stainless steel, carbon steel complying with AAMA 907, or other corrosion-resistant material compatible with vinyl; designed to smoothly operate, tightly close, and securely lock vinyl windows, and sized to accommodate sash or ventilator weight and dimensions. Do not use aluminum in frictional contact with other metals.
 - B. Sill Cap/Track: of thickness, dimensions, and profile indicated; designed to comply with performance requirements indicated and to drain to the exterior.
 - C. Locks and Latches: Designed to allow unobstructed movement of the sash across adjacent sash in direction indicated and operated from the inside only.
 - D. Roller Assemblies: Low-friction design.
 - E. Windows at second floor and windows with the sill opening 6'-0" above grade shall be provided with Window Opening Control Device; device shall meet the ASTM F 2090 - Standard specification for window fall prevention devices with emergency escape (egress) release mechanisms.
- 2.6 INSECT SCREENS
- A. Delete this Article if insect screens are not needed. Copy and revise Article if other types of screens, such as solar or protection screens, are required to suit Project. Revise first paragraph below if screens are located both inside and outside of window sashes or ventilators; differentiate here, on Drawings, or in a window schedule.
 - B. General: Design windows and hardware to accommodate screens in a tight-fitting, removable arrangement, with a minimum of exposed fasteners and latches. Fabricate insect screens to fully integrate with window frame.
- 2.7 WINDOW SILLS
- A. All interior window sills/ledges shall be moisture resistant cultured marble, 1/2" min. thickness

PART 3 - EXECUTION

- 3.1 EXAMINATION
- A. Examine openings, substrates, structural support, anchorage, and conditions, with Installer present, for compliance with requirements for installation tolerances and other conditions affecting performance of work. Verify rough opening dimensions, levelness of sill plate, and operational clearances. Examine wall flashings, vapor retarders, water and weather barriers, and other built-in components to ensure a coordinated, weathertight window installation.
 1. Masonry Surfaces: Visibly dry and free of excess mortar, sand, and other construction debris.
 2. Wood Frame Walls: Dry, clean, sound, well nailed, free of voids, and without offsets at joints. Ensure nail heads are driven flush with surfaces in opening and within **3 inches (76 mm)** of opening.
 3. Metal Surfaces: Dry; clean; free of grease, oil, dirt, rust, corrosion, and welding slag; without sharp edges or offsets at joints.
 4. Proceed with installation only after unsatisfactory conditions have been corrected.
- 3.2 INSTALLATION
- A. Comply with Drawings, Shop Drawings, and manufacturer's written instructions for installing windows, hardware, accessories, and other components.

- B. Install windows level, plumb, square, true to line, without distortion or impeding thermal movement, anchored securely in place to structural support, and in proper relation to wall flashing and other adjacent construction.
- C. Set sill members in bed of sealant or with gaskets, as indicated, for weathertight construction.
- D. Separate aluminum and other corrodible surfaces from sources of corrosion or electrolytic action at points of contact with other materials.

3.3 ADJUSTING, CLEANING, AND PROTECTION

- A. Adjust operating sashes and ventilators, screens, hardware, and accessories for a tight fit at contact points and weather stripping for smooth operation and weathertight closure. Lubricate hardware and moving parts.
- B. Clean exposed surfaces immediately after installing windows. Avoid damaging protective coatings and finishes. Remove excess sealants, glazing materials, dirt, and other substances.
- C. Clean factory-glazed glass immediately after installing windows. Comply with manufacturer's written recommendations for final cleaning and maintenance. Remove nonpermanent labels, and clean surfaces.
- D. Remove and replace glass that has been broken, chipped, cracked, abraded, or damaged during construction period.
- E. Protect window surfaces from contact with contaminating substances resulting from construction operations. In addition, monitor window surfaces adjacent to and below exterior concrete and masonry surfaces during construction for presence of dirt, scum, alkaline deposits, stains, or other contaminants. If contaminating substances do contact window surfaces, remove contaminants immediately according to manufacturer's written recommendations.

END OF SECTION 085313

SECTION 08710

DOOR HARDWARE

PART 1 GENERAL

1.01 SECTION INCLUDES

- A. Hardware for wood, hollow steel, metal insulated and aluminum doors.
- B. Thresholds.
- C. Weatherstripping, seals and door gaskets.

1.03 REFERENCES

- A. ANSI A117.1 - Specifications for Making Buildings and Facilities Accessible to and Usable by Physically Handicapped People.
- B. ADAAG: ADA Accessibility Guidelines for Buildings and Facilities

1.04 OPERATION AND MAINTENANCE DATA

- A. Maintenance Data: Include data on operating hardware, lubrication requirements, and inspection procedures related to preventative maintenance.

1.05 QUALIFICATIONS

- A. Manufacturer: Company specializing in manufacturing the Products specified in this section with minimum 3 years' documented experience.
- B. Hardware Supplier: Company specializing in supplying commercial door hardware with 3 years' documented experience approved by manufacturer.

1.06 DELIVERY, STORAGE, AND HANDLING

- A. Deliver, store, protect, and handle products to site.
- B. Package hardware items individually; label and identify each package with door opening code to match hardware schedule.
- C. Deliver keys to Owner by security shipment direct from hardware supplier.

1.07 WARRANTY

- A. Provide five year warranty.

1.08 MAINTENANCE MATERIALS

- A. Provide special wrenches and tools applicable to each different or special hardware component.
- B. Provide maintenance tools and accessories supplied by hardware component manufacturer.

PART 2 PRODUCTS

2.01 KEYING

- A. Door Locks: Master keyed. Include construction keying, and key to existing keying system.

2.02 HNGES

- A. Butts and Hinges: BHMA A156.1.
- B. Template Hinge Dimensions: BHMA A156.7.
- C. Manufacturers:
 - 1. Baldwin Hardware Corporation (BH).
 - 2. Bommer Industries, Inc. (BI).
 - 3. Cal-Royal Products, Inc. (CRP).
 - 4. Hager Companies (HAG).
 - 5. Lawrence Brothers, Inc. (LB).
 - 6. McKinney Products Company; an ASSA ABLOY Group company (MCK).
 - 7. PBB, Inc. (PBB).
 - 8. Stanley Commercial Hardware; Div. of The Stanley Works (STH).

2.03 LOCKS AND LATCHES, GENERAL

- A. Accessibility Requirements: Comply with accessibility requirements, comply with the U.S. Architectural & Transportation Barriers Compliance Board's "Americans with Disabilities Act (ADA), Accessibility Guidelines for Buildings and Facilities (ADAAG)." ANSI A117.1. FED-STD-795, "Uniform Federal Accessibility Standards."
 - 1. Provide operating devices that do not require tight grasping, pinching, or twisting of the wrist and that operate with a force of not more than 5 lbf (22 N).
 - 2. At all Pocket Doors (located on the first floor, only) – install with ADA Pocket Door Pulls, Trimco 1069 Series or equivalent.
- B. Latches and Locks for Means of Egress Doors: Comply with NFPA 101. Latches shall not require more than 15 lbf (67 N) to release the latch. Locks shall not require use of a key, tool, or special knowledge for operation.

2.04 MECHANICAL LOCKS AND LATCHES

- A. Lock Functions: Function numbers and descriptions indicated in door hardware sets comply with the following:
 - 1. Bored Locks: BHMA A156.2.
 - 2. Mortise Locks: BHMA A156.13.
 - 3. Interconnected Locks: BHMA A156.12.
- B. Bored Locks:
 - 1. Manufacturers:
 - a. Best Access Systems; Div. of The Stanley Works (BAS).
 - b. Corbin Russwin Architectural Hardware; an ASSA ABLOY Group company (CR).
 - c. SARGENT Manufacturing Company; an ASSA ABLOY Group company (SGT).
 - d. Schlage Commercial Lock Division; an Ingersoll-Rand Company (SCH).
 - e. Yale Commercial Locks and Hardware; an ASSA ABLOY Group company (YAL).

2.05 KEYING

- A. Keying System: Factory registered, complying with guidelines in BHMA A156.28, Appendix A. Incorporate decisions made in keying conference, and as follows:
 - 1. Master Key System: Cylinders are operated by a change key and a master key.
- B. Keys: Nickel silver.
 - 1. Quantity: In addition to one extra key blank for each lock, provide the following:
 - a. Cylinder Change Keys: Three.
 - b. Master Keys: Five.
 - c. Grand Master Keys: Five.
 - d. Great-Grand Master Keys: Five.

2.06 CLOSERS

- A. Accessibility Requirements: Where handles, pulls, latches, locks, and other operating devices are indicated to comply with accessibility requirements, comply with [the U.S. Architectural & Transportation Barriers Compliance Board's "Americans with Disabilities Act (ADA), Accessibility Guidelines for Buildings and Facilities (ADAAG).", ANSI A117.1., FED-STD-795, "Uniform Federal Accessibility Standards."
 - 1. Comply with the following maximum opening-force requirements:
 - a. Interior, Non-Fire-Rated Hinged Doors: 5 lbf (22.2 N) applied perpendicular to door.
 - b. Sliding or Folding Doors: 5 lbf (22.2 N) applied parallel to door at latch.
 - c. Fire Doors: Minimum opening force allowable by authorities having jurisdiction.
- B. Door Closers for Means of Egress Doors: Comply with NFPA 101. Door closers shall not require more than 30 lbf (133 N) to set door in motion and not more than 15 lbf (67 N) to open door to minimum required width.
- C. Hold-Open Closers/Detectors: Coordinate and interface integral smoke detector and closer device with fire alarm system.
- D. Flush Floor Plates: Provide finish cover plates for floor closers unless thresholds are indicated. Match door hardware finish, unless otherwise indicated.
- E. Recessed Floor Plates: Provide recessed floor plates with insert of floor finish material for floor closers unless thresholds are indicated. Provide extended closer spindle to accommodate thickness of floor finish.

- F. Power-Assist Closers: As specified in Division 8 Section "Automatic Door Operators" for access doors for people with disabilities or where listed in the door hardware sets.
- G. Size of Units: Unless otherwise indicated, comply with manufacturer's written recommendations for size of door closers depending on size of door, exposure to weather, and anticipated frequency of use. Provide factory-sized closers, adjustable to meet field conditions and requirements for opening force.
- H. Surface Closers: Provide type of arm required for closer to be located on non-public side of door, unless otherwise indicated.
 - 1. Manufacturers:
 - a. Corbin Russwin Architectural Hardware; an ASSA ABLOY Group company (CR).
 - b. LCN Closers; an Ingersoll-Rand Company (LCN).
 - c. Norton Door Controls; an ASSA ABLOY Group company (NDC).
 - d. SARGENT Manufacturing Company; an ASSA ABLOY Group company (SGT).
 - e. Yale Commercial Locks and Hardware; an ASSA ABLOY Group company (YAL).
- I. Concealed Closers:
 - 1. Manufacturers:
 - a. LCN Closers; an Ingersoll-Rand Company (LCN).
 - b. Norton Door Controls; an ASSA ABLOY Group company (NDC).
 - c. SARGENT Manufacturing Company; an ASSA ABLOY Group company (SGT).

2.07 STOPS AND HOLDERS

- A. Stops and Bumpers:
 - 1. Provide floor stops for doors unless wall or other type stops are scheduled or indicated. Do not mount floor stops where they will impede traffic. Where floor or wall stops are not appropriate, provide overhead holders.
- B. Silencers for Wood Door Frames: BHMA A156.16, Grade 1; neoprene or rubber, minimum 5/8 by 3/4 inch (16 by 19 mm); fabricated for drilled-in application to frame.
- C. Silencers for Metal Door Frames: BHMA A156.16, Grade 1; neoprene or rubber, minimum diameter 1/2 inch (13 mm); fabricated for drilled-in application to frame.
- D. Manufacturers:
 - 1. Baldwin Hardware Corporation (BH).
 - 2. Cal-Royal Products, Inc. (CRP).
 - 3. Glynn-Johnson; an Ingersoll-Rand Company (GJ).
 - 4. Hager Companies (HAG).
 - 5. Hiawatha, Inc. (HIA).
 - 6. IVES Hardware; an Ingersoll-Rand Company (IVS).
 - 7. Rockwood Manufacturing Company (RM).
 - 8. SARGENT Manufacturing Company; an ASSA ABLOY Group company (SGT).
 - 9. Stanley Commercial Hardware; Div. of The Stanley Works (STH).

2.08 DOOR GASKETING

- A. General: Provide continuous weather-strip gasketing on exterior doors and provide smoke, light, or sound gasketing on interior doors where indicated or scheduled. Provide noncorrosive fasteners for exterior applications and elsewhere as indicated.
 - 1. Perimeter Gasketing: Apply to head and jamb, forming seal between door and frame.
 - 2. Meeting Stile Gasketing: Fasten to meeting stiles, forming seal when doors are closed.
 - 3. Door Bottoms: Apply to bottom of door, forming seal with threshold when door is closed.
- B. Air Leakage: Not to exceed 0.50 cfm per foot (0.000774 cu. m/s per m) of crack length for gasketing other than for smoke control, as tested according to ASTM E 283.
- C. Smoke-Labeled Gasketing: Assemblies complying with NFPA 105 that are listed and labeled by a testing and inspecting agency acceptable to authorities having jurisdiction, for smoke-control ratings indicated, based on testing according to UL 1784.
 - 1. Provide smoke-labeled gasketing on 20-minute-rated doors and on smoke-labeled doors.
- D. Sound-Rated Gasketing: Assemblies that are listed and labeled by a testing and inspecting agency, for sound ratings indicated, based on testing according to ASTM E 1408.
- E. Replaceable Seal Strips: Provide only those units where resilient or flexible seal strips are easily replaceable and readily available from stocks maintained by manufacturer.
- F. Gasketing Materials: ASTM D 2000 and AAMA 701/702.
- G. Manufacturers:
 - 1. Hager Companies (HAG).

2. National Guard Products (NGP).
3. Pemko Manufacturing Co. (PEM).
4. Zero International (ZRO).

2.09 THRESHOLDS

- A. Accessibility Requirements: Where thresholds are indicated to comply with accessibility requirements, comply with [the U.S. Architectural & Transportation Barriers Compliance Board's "Americans with Disabilities Act (ADA), Accessibility Guidelines for Buildings and Facilities (ADAAG).", ANSI A117.1., FED-STD-795, "Uniform Federal Accessibility Standards."]
- B. Thresholds for Means of Egress Doors: Comply with NFPA 101. Maximum 1/2 inch (13 mm) high.
- C. Manufacturers:
 1. Hager Companies (HAG).
 2. National Guard Products (NGP).
 3. Pemko Manufacturing Co. (PEM).
 4. Zero International (ZRO).

2.10 DOOR VIEWERS

- A. All sight and hearing accessible units are to be equipped with identification devices for visually identifying a visitor without opening the door and allows for a minimum 180-degree range of view.
- B. Accessibility Requirements: Where door viewers are indicated to comply with accessibility requirements, comply with [the U.S. Architectural & Transportation Barriers Compliance Board's "Americans with Disabilities Act (ADA), Accessibility Guidelines for Buildings and Facilities (ADAAG).", ANSI A117.1., FED-STD-795, "Uniform Federal Accessibility Standards."]
- C. Manufacturers:
 1. Hager Companies (HAG).
 2. Pemko Manufacturing Co. (PEM).
 3. Zero International (ZRO).

2.11 FABRICATION

- A. Base Metals: Produce door hardware units of base metal, fabricated by forming method indicated, using manufacturer's standard metal alloy, composition, temper, and hardness. Furnish metals of a quality equal to or greater than that of specified door hardware units and BHMA A156.18. Do not furnish manufacturer's standard materials or forming methods if different from specified standard.
- B. Fasteners: Provide door hardware manufactured to comply with published templates generally prepared for machine, wood, and sheet metal screws. Provide screws according to commercially recognized industry standards for application intended, except aluminum fasteners are not permitted. Provide Phillips flat-head screws with finished heads to match surface of door hardware, unless otherwise indicated.
 1. Concealed Fasteners: For door hardware units that are exposed when door is closed, except for units already specified with concealed fasteners. Do not use through bolts for installation where bolt head or nut on opposite face is exposed unless it is the only means of securely attaching the door hardware. Where through bolts are used on hollow door and frame construction, provide sleeves for each through bolt.
 2. Steel Machine or Wood Screws: For the following fire-rated applications:
 - a. Mortise hinges to doors.
 - b. Strike plates to frames.
 - c. Closers to doors and frames.
 3. Steel Through Bolts: For the following fire-rated applications unless door blocking is provided:
 - a. Surface hinges to doors.
 - b. Closers to doors and frames.
 - c. Surface-mounted exit devices.
 4. Spacers or Hex Bolts: For through bolting of hollow-metal doors.
 5. Fasteners for Wood Doors: Comply with requirements in DHI WDHS.2, "Recommended Fasteners for Wood Doors."

2.11 FINISHES

- A. Standard: BHMA A156.18, as indicated in door hardware sets.
- B. Protect mechanical finishes on exposed surfaces from damage by applying a strippable, temporary protective covering before shipping.

- C. Appearance of Finished Work: Variations in appearance of abutting or adjacent pieces are acceptable if they are within one-half of the range of approved Samples. Noticeable variations in the same piece are not acceptable. Variations in appearance of other components are acceptable if they are within the range of approved Samples and are assembled or installed to minimize contrast.

PART 3 EXECUTION

3.01 EXAMINATION

- A. Verify that doors and frames are ready to receive work and dimensions are as indicated on shop drawings.
- B. Verify that electric power is available to power operated devices and of the correct characteristics.
- C. Examine doors and frames, with Installer present, for compliance with requirements for installation tolerances, labeled fire door assembly construction, wall and floor construction, and other conditions affecting performance.
- D. Examine roughing-in for electrical power systems to verify actual locations of wiring connections before electrified door hardware installation.
- E. Proceed with installation only after unsatisfactory conditions have been corrected.

3.02 INSTALLATION

- A. Install hardware in accordance with manufacturer's instructions.
- B. Use templates provided by hardware item manufacturer.
- C. Mounting heights for hardware from finished floor to center line of hardware item:
 - 1. Locksets: 40"
 - 2. Push/Pulls: 45"
 - 3. Dead Locks: 54"
 - 4. Exit Devices: 42"
- D. Install each door hardware item to comply with manufacturer's written instructions. Where cutting and fitting are required to install door hardware onto or into surfaces that are later to be painted or finished in another way, coordinate removal, storage, and reinstallation of surface protective trim units with finishing work specified in Division 9 Sections. Do not install surface-mounted items until finishes have been completed on substrates involved.
 - 1. Set units level, plumb, and true to line and location. Adjust and reinforce attachment substrates as necessary for proper installation and operation.
 - 2. Drill and countersink units that are not factory prepared for anchorage fasteners. Space fasteners and anchors according to industry standards.
- E. Thresholds: Set thresholds for exterior and acoustical doors in full bed of sealant complying with requirements specified in Division 7 Section "Joint Sealants."

3.03 ADJUSTING

- A. Initial Adjustment: Adjust and check each operating item of door hardware and each door to ensure proper operation or function of every unit. Replace units that cannot be adjusted to operate as intended. Adjust door control devices to compensate for final operation of heating and ventilating equipment and to comply with referenced accessibility requirements.
 - 1. Spring Hinges: Adjust to achieve positive latching when door is allowed to close freely from an open position of 30 degrees.
 - 2. Electric Strikes: Adjust horizontal and vertical alignment of keeper to properly engage lock bolt.
 - 3. Door Closers: Unless otherwise required by authorities having jurisdiction, adjust sweep period so that, from an open position of 70 degrees, the door will take at least 3 seconds to move to a point 3 inches (75 mm) from the latch, measured to the leading edge of the door. Requirements in paragraph below increase cost but are recommended as a good investment on substantial projects even though they may be difficult to monitor.

Occupancy Adjustment: Approximately three months after date of Substantial Completion, Installer's Architectural Hardware Consultant shall examine and readjust, including adjusting operating forces, each item of door hardware as necessary to ensure function of doors, door hardware, and electrified door hardware.

END OF SECTION 08710

SECTION 08800

GLAZING

PART 1 GENERAL

1.01 SECTION INCLUDES

- A. Glass and glazing for Sections referencing this Section for products and installation.

1.02 PERFORMANCE REQUIREMENTS

- A. Glass and glazing materials of this Section shall provide continuity of building enclosure vapor and air barrier:
 - 1. To utilize the inner pane of multiple pane sealed units for the continuity of the air and vapor seal.
 - 2. Maintain continuous air and vapor barrier throughout glazed assembly from glass pane to heel bead of glazing sealant.
- B. Size glass to withstand dead loads and positive and negative live loads acting normal to plane of glass as calculated in accordance with UBC 91 code.
- C. Limit glass deflection to 1/200 flexure limit of glass with full recovery of glazing materials, whichever is less.

1.03 ENVIRONMENTAL REQUIREMENTS

- A. Do not install glazing when ambient temperature is less than 50 degrees F.
- B. Maintain minimum ambient temperature before, during and 24 hours after installation of glazing compounds.

1.04 FIELD MEASUREMENTS

- A. Verify that field measurements are as indicated on shop drawings.

1.05 COORDINATION

- A. Coordinate the Work with glazing frames, wall openings, and perimeter air and vapor seal to adjacent Work.

1.06 WARRANTY

- A. Provide five year manufacturer's warranty.
- B. Warranty: Include coverage for sealed glass units from seal failure, interpane dusting, or misting, reflective coating on mirrors, delamination of laminated glass and replacement of same.

PART 2 PRODUCTS

2.01 FLAT GLASS MATERIALS

- A. Float Glass (Type FG): Clear, 1/4 inch thick minimum.
- B. Safety Glass (Type SG): Clear; fully tempered with horizontal tempering 1/4 inch thick minimum at all locations where glass is less than 18 inches above finished floor.
- C. Tinted Glass (Type TG): Float type, heat strengthened, light reducing, color (to be selected); 1/4 inch thick minimum.
- D. Mirror Glass (Type MG): Clear with copper and silver coating, organic overcoating, beveled edges, 1/4 inch thick minimum, sizes as indicated.

2.02 SEALED INSULATING GLASS MATERIALS

- A. Insulated Glass Units (Type IG): ASTM E774 and E773; double pane with edge seal; outer pane of 1/4 inch glass tinted at exterior, inner pane of 1/4 inch glass.
 - 1. **Must Meet 2021 IECC Compliance and Energy Star Multi-Family New Construction Program Version 1.1 for Climate Zone 6.** Reference Section 08313 Vinyl Windows & Section 08111 Standard Doors & Frames for additional information.

2.03 GLAZING COMPOUNDS

- A. Exterior windows not shop installed shall be glazed with vinyl or neoprene gaskets, extruded elastic polybutene tape sealant, a combination of polysulphide base compound and elastic glazing compound,

or a combination of extruded polysulphide tape, polysulphide base compound elastic glazing compound.

- B. Doors and interior stopped -in glass shall be glazed using putty or elastic glazing compound and stop beads.
 - C. Exterior glazing of steel sash shall be DAP Metal Glaze. Interior glazing of steel sash shall be DAP Steel Sash Putty.
- 2.04 GLAZING ACCESSORIES
- A. Setting Blocks: Neoprene or Silicone, 80 - 90 Shore A durometer hardness, length of 0.1 inch for each square foot of glazing or minimum 4 inch x width of glazing rabbet space minus 1/16 inch x height to suit glazing method and pane weight and area.
 - B. Spacer Shims: Neoprene or Silicone, 50 - 60 Shore A durometer hardness, minimum 3 inch long x one half the height of the glazing stop x thickness to suit application, self adhesive on one face.
 - C. Glazing Tape: Preformed butyl compound with integral resilient tube spacing device; 10 - 15 Shore A durometer hardness; coiled on release paper.
 - D. Glazing Clips: Manufacturer's standard type.
 - E. Mirror Attachment Accessories: Mirror adhesive, chemically compatible with mirror coating and wall substrate.

PART 3 EXECUTION

3.01 EXAMINATION

- A. Verify that openings for glazing are correctly sized and within tolerance.
- B. Verify that surfaces of glazing channels or recesses are clean, free of obstructions, and ready to receive glazing.

3.02 PREPARATION

- A. Clean contact surfaces with solvent and wipe dry.
- B. Seal porous glazing channels or recesses with substrate compatible primer or sealer.
- C. Prime surfaces scheduled to receive sealant.
- D. Install glazing in accordance with Flat Jobbers Association Glazing Manual.

3.03 INSTALLATION - MIRRORS

- A. Set mirrors with adhesive, applied in accordance with adhesive manufacturer's instructions.
- B. Place plumb and level.

3.04 CLEANING

- A. Remove glazing materials from finish surfaces. Remove labels after work is complete. Clean glass and mirrors.

3.05 PROTECTION OF FINISHED WORK

- A. After installation, mark pane with an "X" by using removable plastic tape or paste. Do not mark heat absorbing or reflective glass units.

END OF SECTION 08800

SECTION 09260

GYPSUM BOARD SYSTEMS

PART 1 GENERAL

1.01 SECTION INCLUDES

- A. Acoustical insulation.
- B. Gypsum board.
- D. Taped and sanded joint treatment.
- E. Texture finish.

1.02 REFERENCES

- A. ASTM C36 - Gypsum Wallboard.
- B. ASTM C475 - Joint Treatment Materials for Gypsum Wallboard Construction.
- C. ASTM C630 - Water Resistant Gypsum Backing Board.

PART 2 PRODUCTS

2.01 MANUFACTURERS - GYPSUM BOARD SYSTEM

- A. United States Gypsum.
- B. Other acceptable manufacturers offering equivalent products.
- C. Substitutions: Under provisions of the General Requirements.

2.02 FRAMING MATERIALS

- A. Studs and Tracks: Wood 2x4 and 2x6 framing. Refer to Section 06112 unless noted otherwise.
- B. Furring, Framing and Accessories: ASTM C645. Galvanized sheet steel, 25 gage thick, unless noted otherwise.
- C. Anchorage to Substrate: Tie wire, nails, screws and other metal supports, of type and size to suit application; to rigidly secure materials in place.
- D. Adhesive: ASTM C557.

2.03 GYPSUM BOARD MATERIALS

- A. Fire Rated Gypsum Board: ASTM C36; fire resistive type, UL rated; 5/8 inch thick, maximum permissible length; ends square cut, tapered edges.
- B. Moisture Resistant Gypsum Board: (At all wet areas) ASTM C630; 5/8 inch thick, maximum permissible length; ends square cut, tapered edges.

2.04 ACCESSORIES

- A. Acoustical Insulation: ASTM C665; preformed glass fiber, friction fit type, unfaced, 3-1/2 inch thick.
- B. Corner Beads: Metal.
- C. Edge Trim: GA 201 and GA 216; Type L bead.
- D. Joint Materials: ASTM C475; reinforcing tape, joint compound, adhesive, and water.
- E. Fasteners: ASTM C1002, Type S12, W, and GA-216.
- F. Resilient channel: USG, RC-1 or equal.

PART 3 EXECUTION

3.01 EXAMINATION

- A. Verify that site conditions are ready to receive work and opening dimensions are as indicated on shop drawings.

3.02 WOOD STUD INSTALLATION

- A. Stud Spacing: Reference Structural drawings for stud spacing.
- B. Refer to Drawings for indication of partitions, extend stud framing through the ceiling to the structure above, unless noted otherwise. Maintain clearance under structural building members to avoid deflection transfer to studs. Provide extended leg ceiling runners.
- C. Door Opening Framing: Install double studs at door frame jambs.
- D. Blocking: Nail wood blocking to studs or Bolt or screw steel channels to studs. Install blocking for support of plumbing fixtures, toilet partitions, wall cabinets, toilet accessories, and hardware.

- 3.03 WALL FURRING INSTALLATION
- A. Erect wall furring for direct attachment to concrete walls.
 - B. Erect furring channels vertically; space maximum 16 inches on center, not more than 4 inches from floor and ceiling lines, abutting walls.
 - C. Install thermal insulation between furring channels directly attached to concrete masonry walls in accordance with manufacturer's instructions.
- 3.04 FURRING FOR FIRE RATINGS
- A. Install furring as required for fire resistance ratings indicated.
- 3.05 CEILING FRAMING INSTALLATION
- A. Coordinate location of hangers with other work.
 - B. Install ceiling framing independent of walls, columns, and above ceiling work.
 - C. Reinforce openings in ceiling suspension system which interrupt main carrying channels or furring channels, with lateral channel bracing. Extend bracing minimum 24 inches past each end of openings.
 - D. Laterally brace entire suspension system.
- 3.06 ACOUSTICAL ACCESSORIES INSTALLATION
- A. Install resilient channels at maximum 24 inches on center. Locate joints over framing members.
 - B. Place acoustical insulation in partitions tight within spaces, around cut openings, behind and around electrical and mechanical items within or behind partitions, and tight to items passing through partitions.
- 3.07 GYPSUM BOARD INSTALLATION
- A. Install gypsum board in accordance with manufacturer's instructions.
 - B. Erect single layer standard gypsum board vertical, with ends and edges occurring over firm bearing.
 - C. Erect single layer fire rated gypsum board vertically, with edges and ends occurring over firm bearing.
 - D. Use screws when fastening gypsum board to metal furring or framing.
 - E. Place second layer perpendicular to first layer. Offset joints of second layer from joints of first layer.
 - F. Erect exterior gypsum soffit board perpendicular to supports, with staggered end joints over supports.
 - G. Treat cut edges and holes in moisture resistant gypsum board and exterior gypsum soffit board with sealant.
 - H. Place control joints consistent with lines of building spaces as directed.
 - I. Place corner beads at external corners as indicated. Use longest practical length. Place edge trim where gypsum board abuts dissimilar materials as indicated.
 - J. Caulk at sound walls.
- 3.08 JOINT TREATMENT
- A. Tape, fill, and sand exposed joints, edges, and corners to produce smooth surface ready to receive finishes.
 - B. Feather coats onto adjoining surfaces so that camber is maximum 1/32.
 - C. Taping, filling, and sanding is not required at surfaces behind adhesive applied ceramic tile.
 - D. Tape joints and corners of cementitious backing board.
- 3.09 TOLERANCES
- A. Maximum Variation of Finished Gypsum Board Surface from True Flatness: 1/8 inch in 10 feet in any direction.

END OF SECTION 09260

SECTION 09306

FLOOR AND WALL TILE

PART 1 GENERAL

1.01 SECTION INCLUDES

- A. Ceramic tile floor finish using the thinset application method.
- B. Ceramic tile wall finish using the thinset application method.

1.02 SUBMITTALS

- A. Submit under provisions of the General Requirements.
- B. Product Data: Provide instructions for using adhesives and grouts.
- C. Samples: Submit two samples illustrating pattern, color variations, and grout color.

1.03 DELIVERY, STORAGE, AND HANDLING

- A. Deliver, store, protect, and handle products to site.
- B. Protect adhesives from freezing or overheating in accordance with manufacturer's instructions.

1.04 ENVIRONMENTAL REQUIREMENTS

- A. Do not install adhesives in an unventilated environment.
- B. Maintain 50 degrees F during installation of mortar materials.

PART 2 PRODUCTS

2.01 TILE MANUFACTURERS

- A. FLOOR: Ceramic Tile – Products size as indicated on drawings and as selected by owner.
- B. WALL: Ceramic Tile – Products size as indicated on drawings and as selected by owner.
- B. Substitutions: Under provisions of the General Requirements as equal or better.

2.02 CERAMIC TILE MATERIALS

- A. Ceramic Floor Tile: ANSI A137.1, conforming to the following:
 - 1. Moisture Absorption 0.5 to 3.0 percent
 - 2. Size Reference Drawings
 - 3. Shape square/rectangular
 - 4. Edge square/bullnose
 - 5. Surface Finish matte glazed slip resistant
 - 6. Color as selected
 - 7. Pattern uncoursed
- B. Glazed Wall Tile: Flat tile as follows:
 - 1. Module Size: Products size as indicated on drawings and as selected by owner.
 - 2. Finish: As Selected

2.03 BASE MATERIALS

- A. Base: Match floor tile for moisture absorption, surface finish, and color:
 - 1. Length Products size as indicated on drawings
 - 2. Height Products size as indicated on drawings
 - 3. Top Edge bull nosed
 - 4. Internal Corner coved
 - 5. External Corner bullnosed

2.04 ADHESIVE MATERIALS

- A. Adhesives: thinset bond type as recommended and/or manufactured by the tile manufacturer.

2.05 MORTAR MATERIALS

- A. Mortar Materials: Portland cement, sand, latex additive, and water as recommended and/or manufactured by the tile manufacturer, color to be selected.

2.06 GROUT MIX

- A. Mix and proportion pre-mix grout materials in accordance with manufacturer's instructions.

PART 3 EXECUTION

3.01 EXAMINATION

- A. Verify that surfaces are ready to receive work.

3.02 PREPARATION

- A. Protect surrounding work from damage or disfiguration.
- B. Vacuum clean surfaces and damp clean.
- C. Seal substrate surface cracks with filler. Level existing substrate surfaces to acceptable flatness tolerances.
- D. Apply sealer conditioner to substrate surfaces in accordance with adhesive manufacturer's instructions.

3.03 INSTALLATION - THINSET METHOD

- A. Install adhesive tile, thresholds, and grout in accordance with manufacturer's instructions and/or the TCA Handbook.
- B. Lay tile to pattern indicated. Do not interrupt tile pattern through openings.
- C. Place edge strips at exposed tile edges.
- D. Cut and fit tile tight to penetrations through tile. Form corners and bases neatly. Align floor, base and wall joints.
- E. Place tile joints uniform in width, subject to variance in tolerance allowed in tile size. Make joints watertight, without voids, cracks, excess mortar, or excess grout.
- F. Sound tile after setting. Replace hollow sounding units.
- G. Keep expansion, control joints free of adhesive or grout. Apply sealant to joints.
- H. Allow tile to set for a minimum of 48 hours prior to grouting.
- I. Grout tile joints.
- J. Apply sealant to junction of tile and dissimilar materials and junction of dissimilar planes.
- K. Install shower pan per manufacturer's instructions.

3.04 CLEANING

- A. Clean tile and grout surfaces.

3.05 PROTECTION OF FINISHED WORK

- A. Do not permit traffic over finished floor surface for 4 days after installation.

END OF SECTION 09306

SECTION 09650

RESILIENT FLOORING

PART 1 GENERAL

1.01 SECTION INCLUDES

- A. Vinyl Tile Flooring and Vinyl Plank Flooring

1.03 DELIVERY, STORAGE, AND HANDLING

- A. Deliver, store, protect and handle products to site under provisions of the General Requirements.
- B. Protect roll materials from damage.

1.04 ENVIRONMENTAL REQUIREMENTS

- A. Store materials for three days prior to installation in area of installation to achieve temperature stability.
- B. Maintain ambient temperature required by adhesive manufacturer three days prior to, during, and 24 hours after installation of materials.

1.05 MAINTENANCE DATA

- A. Maintenance Data: Include maintenance procedures, recommended maintenance materials, and suggested schedule for cleaning, stripping, and re-waxing.

1.06 EXTRA MATERIALS

- A. Provide 60 sq ft of flooring, 10 lineal feet of base, and stair materials of each material specified.

PART 2 PRODUCTS

2.01 MATERIALS – VINYL PLANK FLOORING

- A. Plank Flooring: Vinyl Plank Flooring shall be selected from the **Mohawk, Living Local, Premium Wood Collection** or approved equal.
 1. Apartment Units – min. 12 mil wear layer
 2. Clubhouse – min. 20 mil wear layer
 4. Submit Samples, Color & Pattern to be selected by architect
 5. Warranty, min. 15 year warranty

2.02 ACCESSORIES

- A. Subfloor Filler: White premix latex; type recommended by adhesive material manufacturer.
- B. Primers and Adhesives: Waterproof; types recommended by flooring manufacturer.
- C. Edge Strips: Flooring material as approved.
- D. Sealer and Wax: Types recommended by flooring manufacturer.

PART 3 EXECUTION

3.01 EXAMINATION

- A. Verify concrete floors are dry to a maximum moisture content of 7 percent, and exhibit negative alkalinity, carbonization, or dusting.
- B. Verify floor and lower wall surfaces are free of substances that may impair adhesion of new adhesive and finish materials.

- 3.02 PREPARATION
- A. Remove sub-floor ridges and bumps. Fill minor or local low spots, cracks, joints, holes, and other defects with sub-floor filler to achieve smooth, flat, hard surface.
 - B. Prohibit traffic until filler is cured.
 - C. Vacuum clean substrate.
 - D. Apply primer as recommended by manufacturer.
- 3.05 INSTALLATION - TILE FLOORING
- A. Install in accordance with manufacturer's instructions.
 - B. Spread only enough adhesive to permit installation of materials before initial set.
 - C. Set flooring in place, press with heavy roller to attain full adhesion.
 - D. Lay flooring with joints and seams parallel to building lines to produce symmetrical tile pattern.
 - G. Terminate flooring at centerline of door openings where adjacent floor finish is dissimilar.
 - H. Install resilient edge strips at unprotected or exposed edges, and where flooring terminates.
 - G. Scribe flooring to walls, columns, cabinets, floor outlets, and other appurtenances to produce tight joints.
- 3.06 CLEANING
- A. Clean all work as described in the General Requirements.
 - B. Remove access adhesive from floor, base, and wall surfaces without damage.
 - C. Clean, seal, and wax floor and base surfaces in accordance with manufacturer's instructions.
- 3.07 PROTECTION OF FINISHED WORK
- A. Protect finished Work.
 - B. Prohibit traffic on floor finish for 48 hours after installation.

END OF SECTION 09650

SECTION 09680

CARPET – PAD AND TACK

PART 1 - GENERAL

1.1 RELATED DOCUMENTS

- A. Drawings and general provisions of the Contract, including General and Supplementary Conditions and Division 1 Specification Sections, apply to this Section.

1.2 SUMMARY

- A. This Section includes the following:
 - 1. Cut Pile carpet with Pad or Integral backing

1.3 SUBMITTALS

- A. Product Data: For the following, including installation recommendations for each type of substrate:
 - 1. Carpet: For each type indicated. Include manufacturer's written data on physical characteristics, durability, and fade resistance.
 - 2. Carpet Cushion: For each type indicated. Include manufacturer's written data on physical characteristics and durability.
- B. Samples: For each of the following products and for each color and texture required. Label each Sample with manufacturer's name, material description, color, pattern, and designation indicated on Drawings and in schedules.
 - 1. Carpet: 12-inch- (300-mm-) square Sample.
 - 2. Exposed Edge, Transition, and other Accessory Stripping: 12-inch- (300-mm-) long Samples.
 - 3. Carpet Cushion: 6-inch- (150-mm-) square Sample.
 - 4. Carpet Seam: 6-inch (150-mm) Sample.
 - 5. Mitered Carpet Border Seam: 12-inch- (300-mm-) square Sample. Show carpet pattern alignment.
- C. Product Schedule: For carpet **and carpet cushion**. Use same designations indicated on Drawings.
- D. Qualification Data: For Installer.
- E. Product Test Reports: Based on evaluation of comprehensive tests performed by a qualified testing agency.
- F. Maintenance Data: For carpet to include in maintenance manuals. Include the following:
 - 1. Methods for maintaining carpet, including cleaning and stain-removal products and procedures and manufacturer's recommended maintenance schedule.
 - 2. Precautions for cleaning materials and methods that could be detrimental to carpet **and carpet cushion**.
- G. Warranties: Special warranties specified in this Section.

1.4 QUALITY ASSURANCE

- A. Installer Qualifications: An experienced installer who is certified by the Floor Covering Installation Board or who can demonstrate compliance with its certification program requirements.
- B. Fire-Test-Response Characteristics: Provide products with the critical radiant flux classification indicated in Part 2, as determined by testing identical products per ASTM E 648 by an independent testing and inspecting agency acceptable to authorities having jurisdiction.
- C. Mockups: Before installing carpet, build mockups to verify selections made under sample submittals and to demonstrate aesthetic effects and set quality standards for materials and execution.
 - 1. Approved mockups may become part of the completed Work if undisturbed at time of Substantial Completion.

1.5 DELIVERY, STORAGE, AND HANDLING

- A. Comply with CRI 104, Section 5, "Storage and Handling."

1.6 PROJECT CONDITIONS

- A. Comply with CRI 104, Section 7.2, "Site Conditions; Temperature and Humidity" and Section 7.12, "Ventilation."
- B. Environmental Limitations: Do not install carpet **and carpet cushion** until wet work in spaces is complete and dry, and ambient temperature and humidity conditions are maintained at the levels indicated for Project when occupied for its intended use.
- C. Do not install carpet **and carpet cushion** over concrete slabs until slabs have cured, are sufficiently dry to bond with adhesive, and have pH range recommended by carpet manufacturer.
- D. Where demountable partitions or other items are indicated for installation on top of carpet, install carpet before installing these items.

1.7 WARRANTY

- A. Special Warranty for Carpet: Manufacturer's standard form in which manufacturer agrees to repair or replace components of carpet installation that fail in materials or workmanship within specified warranty period.
 - 1. Warranty does not include deterioration or failure of carpet due to unusual traffic, failure of substrate, vandalism, or abuse.
 - 2. Failures include, but are not limited to, more than 10 percent loss of face fiber, edge raveling, snags, runs, and delamination.
 - 3. Warranty Period: 5 years from date of Substantial Completion.
- B. Special Warranty for Carpet Cushion: Manufacturer's standard form in which manufacturer agrees to repair or replace components of carpet cushion installation that fail in materials or workmanship within specified warranty period.
 - 1. Warranty includes consequent removal and replacement of carpet and accessories.
 - 2. Warranty does not include deterioration or failure of carpet cushion due to unusual traffic, failure of substrate, vandalism, or abuse.
 - 3. Failure includes, but is not limited to, permanent indentation or compression.
 - 4. Warranty Period: 5 years from date of Substantial Completion.

1.8 EXTRA MATERIALS

- A. Furnish extra materials described below, before installation begins, that match products installed and that are packaged with protective covering for storage and identified with labels describing contents.
 - 1. Carpet: Full-width rolls equal to **5** percent of amount installed for each type indicated, but not less than **10 sq. yd. (8.3 sq. m)**.

PART 2 - PRODUCTS

2.1 CUT PILE CARPET

- A. Available Products: Subject to compliance with requirements, products that may be incorporated into the Work include, but are not limited to, the following:
- B. Products: Subject to compliance with requirements, provide one of the following:
 - 1. Manufacturers:**
 - a. Clubhouse, Leasing Office: Shaw, Mainstreet by Philadelphia or approved equal**
 - 1) Submit Samples – **Color to be selected by Architect**, from full range of collection's colors.
- C. Pile Characteristic: Cut pile.
- D. Pile Thickness: 0.16 inch for finished carpet.
- E. Face Weight: 25 oz./Sq. Yd.
- F. Total Weight: 40 oz./Sq. Yd. for finished carpet.
- G. Primary Backing: Manufacturer's standard material.
- H. Secondary Backing: Manufacturer's standard material.
- I. Applied Soil-Resistance Treatment: Manufacturer's standard material
- J. Antimicrobial Treatment: Manufacturer's standard material.

2.2 CARPET CUSHION

- A. Available Products: Subject to compliance with requirements, products that may be incorporated into the Work include, but are not limited to, the following:
- B. Products: Subject to compliance with requirements, provide one of the following:
 - 1. Thickness: 3/8 inch. Min.
 - 2. Density: 6 lbs/cu. ft. Min.

2.3 INSTALLATION ACCESSORIES

- A. Trowelable Leveling and Patching Compounds: Latex-modified, hydraulic-cement-based formulation provided or recommended by carpet cushion manufacturer.
- B. Adhesives: Water-resistant, mildew-resistant, nonstaining type to suit products and subfloor conditions indicated, that complies with flammability requirements for installed carpet and is recommended or provided by carpet manufacturer carpet and carpet cushion manufacturers.
 - 1. VOC Limits: Provide adhesives that comply with the following limits for VOC content when tested according to ASTM D 5116:
 - a. Total VOCs: 10.00 mg/sq. m x h.
 - b. Formaldehyde: 0.05 mg/sq. m x h.
 - c. 2-Ethyl-1-Hexanol: 3.00 mg/sq. m x h.
- C. Tackless Carpet Stripping: Water-resistant plywood, in strips as required to match cushion thickness and that comply with CRI 104, Section 12.2.
- D. Seam Adhesive: Hot-melt adhesive tape or similar product recommended by carpet manufacturer for sealing and taping seams and butting cut edges at backing to form secure seams and to prevent pile loss at seams.
- E. Metal Edge Strips: Extruded aluminum with mill finish of width shown, of height required to protect exposed edge of carpet, and of maximum lengths to minimize running joints.

PART 3 - EXECUTION

3.1 EXAMINATION

- A. Examine substrates, areas, and conditions, with Installer present, for compliance with requirements for maximum moisture content, alkalinity range, installation tolerances, and other conditions affecting carpet performance. Examine carpet for type, color, pattern, and potential defects.
- B. Concrete Subfloors: Verify that concrete slabs comply with ASTM F 710 and the following:
 - 1. Slab substrates are dry and free of curing compounds, sealers, hardeners, and other materials that may interfere with adhesive bond. Determine adhesion and dryness characteristics by performing bond and moisture tests recommended by carpet cushion manufacturer.
 - 2. Subfloor finishes comply with requirements specified in Division 3 Section "Cast-in-Place Concrete" for slabs receiving carpet.
 - 3. Subfloors are free of cracks, ridges, depressions, scale, and foreign deposits.
- C. For wood subfloors, verify the following:
 - 1. Underlayment over subfloor complies with requirements specified in Division 6 Section "Rough Carpentry."
 - 2. Underlayment surface is free of irregularities and substances that may interfere with adhesive bond or show through surface.
- D. Proceed with installation only after unsatisfactory conditions have been corrected.

3.2 PREPARATION

- A. General: Comply with CRI 104, Section 7.3, "Site Conditions; Floor Preparation," and with carpet manufacturer's written installation instructions for preparing substrates.
- B. Use trowelable leveling and patching compounds, according to manufacturer's written instructions, to fill cracks, holes, depressions, and protrusions in substrates. Fill or level cracks, holes and depressions **1/8 inch (3 mm)** wide or wider, and protrusions more than **1/32 inch (0.8 mm)**, unless more stringent requirements are required by manufacturer's written instructions.
- C. Remove coatings, including curing compounds, and other substances that are incompatible with adhesives and that contain soap, wax, oil, or silicone, without using solvents. Use mechanical methods recommended in writing by carpet cushion manufacturer.
- D. Broom and vacuum clean substrates to be covered immediately before installing carpet.

3.3 INSTALLATION

- A. Comply with CRI 104 and carpet manufacturer's carpet and carpet cushion manufacturers' written installation instructions for the following:
 - 1. Direct-Glue-Down Installation: Comply with CRI 104, Section 9, "Direct Glue-Down Installation."
 - 2. Double-Glue-Down Installation: Comply with CRI 104, Section 10, "Double Glue-Down Installation."
 - 3. Carpet with Attached-Cushion Installation: Comply with CRI 104, Section 11, "Attached-Cushion Installations."
 - 4. Stretch-in Installation: Comply with CRI 104, Section 12, "Stretch-in Installation."
 - 5. Stair Installation: Comply with CRI 104, Section 13, "Carpet on Stairs" for stretch-in glue-down installation.
- B. Comply with carpet manufacturer's written recommendations and Shop Drawings for seam locations and direction of carpet; maintain uniformity of carpet direction and lay of pile. At doorways, center seams under the door in closed position.
- C. Do not bridge building expansion joints with carpet.
- D. Cut and fit carpet to butt tightly to vertical surfaces, permanent fixtures, and built-in furniture including cabinets, pipes, outlets, edgings, thresholds, and nosings. Bind or seal cut edges as recommended by carpet manufacturer.
- E. Extend carpet into toe spaces, door reveals, closets, open-bottomed obstructions, removable flanges, alcoves, and similar openings.
- F. Maintain reference markers, holes, and openings that are in place or marked for future cutting by repeating on finish flooring as marked on subfloor. Use nonpermanent, nonstaining marking device.
- G. Install pattern parallel to walls and borders to comply with CRI 104, Section 15, "Patterned Carpet Installations" and with carpet manufacturer's written recommendations.
- H. Comply with carpet cushion manufacturer's written recommendations. Install carpet cushion seams at 90-degree angle with carpet seams.

3.4 CLEANING AND PROTECTING

- A. Perform the following operations immediately after installing carpet:
 - 1. Remove excess adhesive, seam sealer, and other surface blemishes using cleaner recommended by carpet manufacturer.
 - 2. Remove yarns that protrude from carpet surface.
 - 3. Vacuum carpet using commercial machine with face-beater element.
- B. Protect installed carpet to comply with CRI 104, Section 16, "Protection of Indoor Installations."
- C. Protect carpet against damage from construction operations and placement of equipment and fixtures during the remainder of construction period. Use protection methods indicated or recommended in writing by carpet manufacturer and carpet cushion manufacturer.

END OF SECTION 09680

SECTION 09900
PAINTING

PART 1 GENERAL

1.01 SECTION INCLUDES

- A. Surface preparation and field application of paints and coatings.

1.02 QUALIFICATIONS

- A. Manufacturer: Company specializing in manufacturing the Products specified in this section with minimum three years documented experience.
- B. Applicator: Company specializing in performing the work of this section with minimum years documented experience and approved by manufacturer.

1.03 DELIVERY, STORAGE, AND HANDLING

- A. Deliver, store, protect and handle products to site.
- B. Deliver products to site in sealed and labeled containers; inspect to verify acceptability.
- C. Container label to include manufacturer's name, type of paint, brand name, lot number, brand code, coverage, surface preparation, drying time, cleanup requirements, color designation, and instructions for mixing and reducing.
- D. Store paint materials at minimum ambient temperature of 45 degrees F and a maximum of 90 degrees F, in ventilated area, and as required by manufacturer's instructions.

1.04 ENVIRONMENTAL REQUIREMENTS

- A. Do not apply materials when surface and ambient temperatures are outside the temperature ranges required by the paint product manufacturer.
- B. Do not apply exterior coatings during rain or snow, or when relative humidity is outside the humidity ranges required by the paint product manufacturer.
- C. Minimum Application Temperatures for Latex Paints: 45 degrees F for interiors; 50 degrees F for exterior; unless required otherwise by manufacturer's instructions.
- D. Minimum Application Temperature for Varnish and Finishes: 65 degrees F for interior or exterior, unless required otherwise by manufacturer's instructions.
- E. Provide lighting level of 80 foot candles measured mid-height at substrate surface.

PART 2 PRODUCTS

2.01 MANUFACTURERS

- A. Manufacturer - Paint, Transparent Finishes, Stain, Primer Sealers, and Block Filler by SHERWIN-WILLIAMS or as approved equal.

2.02 MATERIALS

- A. Coatings: Ready mixed, except field catalyzed coatings. Process pigments to a soft paste consistency, capable of being readily and uniformly dispersed to a homogeneous coating; good flow and brushing properties; capable of drying or curing free of streaks or sags.
- B. Accessory Materials: Linseed oil, shellac, turpentine, paint thinners and other materials not specifically indicated but required to achieve the finishes specified, of commercial quality.
- C. Patching Materials: Latex filler.
- D. Fastener Head Cover Materials: Latex filler.
- E. All interior paints and primers shall comply with Green Seal standards for low VOC limits.

2.03 FINISHES

- A. Refer to schedule at end of section for surface finish schedule.

PART 3 EXECUTION

3.01 EXAMINATION

- A. Verify that surfaces and substrate conditions are ready to receive work as instructed by the product manufacturer.
- B. Examine surfaces scheduled to be finished prior to commencement of work. Report any condition that may potentially affect proper application.
- C. Test shop applied primer for compatibility with subsequent cover materials.

3.02 PREPARATION

- A. Remove or mask electrical plates, hardware, light fixture trim, escutcheons, and fittings prior to preparing surfaces or finishing.
- B. Correct defects and clean surfaces which affect work of this section. Remove existing coatings that exhibit loose surface defects.
- C. Seal with shellac and seal marks which may bleed through surface finishes.
- D. Impervious Surfaces: Remove mildew by scrubbing with solution of trisodium phosphate and bleach. Rinse with clean water and allow surface to dry.
- E. Aluminum Surfaces Scheduled for Paint Finish: Remove surface contamination by steam or high pressure water. Remove oxidation with acid etch and solvent washing. Apply etching primer immediately following cleaning.
- F. Asphalt, Creosote, or Bituminous Surfaces Scheduled for Paint Finish: Remove foreign particles to permit adhesion of finishing materials. Apply compatible sealer or primer.
- G. Insulated Coverings: Remove dirt, grease, and oil from canvas and cotton.
- H. Concrete Floors: Remove contamination, acid etch, and rinse floors with clear water. Verify required acid-alkali balance is achieved. Allow to dry.
- I. Copper Surfaces Scheduled for a Paint Finish: Remove contamination by steam, high pressure water, or solvent washing. Apply vinyl etch primer immediately following cleaning.
- J. Copper Surfaces Scheduled for a Natural Oxidized Finish: Remove contamination by applying oxidizing solution of copper acetate and ammonium chloride in acetic acid. Rub on repeatedly for required effect. Once attained, rinse surfaces with clear water and allow to dry.
- K. Gypsum Board Surfaces: Fill minor defects with filler compound. Spot prime defects after repair.
- L. Galvanized Surfaces: Remove surface contamination and oils and wash with solvent. Apply coat of etching primer.
- M. Concrete and Unit Masonry Surfaces Scheduled to Receive Paint Finish: Remove dirt, loose mortar, scale, salt or alkali powder, and other foreign matter. Remove oil and grease with a solution of trisodium phosphate; rinse well and allow to dry. Remove stains caused by weathering of corroding metals with a solution of sodium metasilicate after thoroughly wetting with water. Allow to dry.
- N. Plaster Surfaces: Fill hairline cracks, small holes, and imperfections with latex patching plaster. Make smooth and flush with adjacent surfaces. Wash and neutralize high alkali surfaces.
- O. Uncoated Steel and Iron Surfaces: Remove grease, mill scale, weld splatter, dirt, and rust. Where heavy coatings of scale are evident, remove by hand, power tool wire brushing or sandblasting; clean by washing with solvent. Apply a treatment of phosphoric acid solution, ensuring weld joints, bolts, and nuts are similarly cleaned. Spot prime paint after repairs.
- P. Shop Primed Steel Surfaces: Sand and scrape to remove loose primer and rust. Feather edges to make touch-up patches inconspicuous. Clean surfaces with solvent. Prime bare steel surfaces.
- Q. Interior Wood Items Scheduled to Receive Paint Finish: Wipe off dust and grit prior to priming. Seal knots, pitch streaks, and sappy sections with sealer. Fill nail holes and cracks after primer has dried; sand between coats.
- R. Interior Wood Items Scheduled to Receive Transparent Finish: Wipe off dust and grit prior to sealing, seal knots, pitch streaks, and sappy sections with sealer. Fill nail holes and cracks after sealer has dried; sand lightly between coats.
- S. Exterior Wood Scheduled to Receive Paint Finish: Remove dust, grit, and foreign matter. Seal knots, pitch streaks, and sappy sections. Fill nail holes with tinted exterior caulking compound after prime coat has been applied.
- T. Exterior Wood Scheduled to Receive Transparent Finish: Remove dust, grit, and foreign matter; seal knots, pitch streaks, and sappy sections with sealer. Fill nail holes with tinted exterior caulking compound after sealer has been applied.
- U. Glue-Laminated Beams: Prior to finishing, wash surfaces with solvent, remove grease and dirt.
- V. Wood and Metal Doors Scheduled for Painting: Seal top and bottom edges with primer.

3.03 APPLICATION

- A. Apply products in accordance with manufacturer's instructions.
- B. Do not apply finishes to surfaces that are not dry.
- C. Apply each coat to uniform finish.
- D. Apply each coat of paint slightly darker than preceding coat unless otherwise approved.
- E. Sand wood and metal lightly between coats to achieve required finish.
- F. Vacuum clean surfaces free of loose particles. Use tack cloth just prior to applying next coat.
- G. Allow applied coat to dry before next coat is applied.
- H. Where clear finishes are required, tint fillers to match wood. Work fillers into the grain before set. Wipe excess from surface.
- I. Prime concealed surfaces of interior and exterior woodwork with primer paint.
- J. Prime concealed surfaces of interior woodwork scheduled to receive stain or varnish finish with gloss varnish reduced 25 percent with mineral spirits.

3.04 FINISHING MECHANICAL AND ELECTRICAL EQUIPMENT

- A. Remove unfinished louvers, grilles, covers, and access panels on mechanical and electrical components and paint separately.
- B. Prime and paint insulated and exposed pipes, conduit, boxes, insulated and exposed ducts, hangers, brackets, collars and supports except where items are prefinished.
- C. Paint interior surfaces of air ducts, and convector and baseboard heating cabinets that are visible through grilles and louvers with one coat of flat black paint, to visible surfaces. Paint dampers exposed behind louvers, grilles, and convector and baseboard cabinets to match face panels.
- D. Paint exposed conduit and electrical equipment occurring in finished areas.
- E. Paint both sides and edges of plywood backboards for electrical and telephone equipment before installing equipment.
- F. Reinstall electrical cover plates, hardware, light fixture trim, escutcheons, and fittings removed prior to finishing.

3.05 CLEANING

- A. Collect waste material which may constitute a fire hazard, place in closed metal containers and remove daily from site.

3.06 SCHEDULE

The following are for exterior and interior surfaces, and are all products of Sherwin-Williams.

EXTERIOR SURFACES

- 1. WOOD (Excluding Plywood)
 - A. Satin Finish/Latex Base
 - 1st Coat: Exterior Oil Based Wood Primer
 - 2nd Coat: Duration, Satin
 - 3rd Coat: Duration, Satin
- 2. PLYWOOD & SIDING
 - A. Satin Finish/Latex Base
 - 1st Coat: Exterior Oil Based Wood Primer
 - 2nd Coat: Duration, Satin
 - 3rd Coat: Duration, Satin
- 3. FERROUS METAL (Handrails)
 - A. Painted (Gloss Finish/Alkyd Base)
 - 1st Coat: Kem Kromik Primer, B50N2/B50W1
 - 2nd Coat: Industrial Enamel, B54 Series
 - 3rd Coat: Industrial Enamel, B54 Series
 - B. Finish on these items shall be applied to achieve polished or car finish.
- 4. GALVANIZED METAL
 - A. Painted (Satin Finish/Latex Base)
 - 1st Coat: Duration, Satin
 - 2nd Coat: Duration, Satin
- 5. ALUMINUM
 - A. Painted (Satin Finish/Latex Base)
 - 1st Coat: Duration, Satin
 - 2nd Coat: Duration, Satin
- 6. CONCRETE MASONRY UNITS
 - A. Painted (Satin Finish/Latex Base)
 - 1st Coat: Loxon Primer/Sealer
 - 2nd Coat: Duration, Satin
 - 3rd Coat: Duration, Satin
- 7. CONCRETE, STUCCO, BRICK
 - A. Painted (Satin Finish/Latex Base)
 - 1st Coat: Loxon Primer/Sealer
 - 2nd Coat: Duration, Satin
 - 3rd Coat: Duration, Satin
- 8. TRAFFIC AND PARKING LINE MARKING
 - A. Painted (ProMar Traffic Marking Paint)

1st Coat: B29W1-WHITE, or B29Y2-YELLOW

INTERIOR SURFACES

1. WOOD AND PLYWOOD
 - A. Painted (Eg-Shel Finish/Alkyd Base)
 - 1st Coat: ProMar 200 Latex Primer, B49W2
 - 2nd Coat: ProMar 200 Latex Eg-Shel, B20W200
 - 3rd Coat: ProMar 200 Eg-Shel, B20W200
 - B. Stained and Varnished (Clear Finish) Opened Grained Wood
 - 1st Coat: Interior Wood Stain, A48
 - 2nd Coat: Sherwood 100 Fast Dri Semi-Paste Filler D70T1
 - 3rd Coat: Oil Base Gloss Varnish, A66V91
 - 4th Coat: Oil Base Gloss Varnish, A66V91 or Oil Base Satin Varnish, A66F90
2. CONCRETE MASONRY UNITS
 - A. Painted (Eg-Shel Finish/Latex Base)
 - 1st Coat: ProMar Block Filler, B25W1
 - 2nd Coat: ProMar 200 Latex Eg-Shel, B20W200
 - 3rd Coat: ProMar 200 Latex Eg-Shel, B20W200
3. CONCRETE, MASONRY EPOXY SYSTEM (SOLVENT BASE)
 - A. Painted (Gloss Finish)
 - 1st Coat: Tile-Clad II Epoxy, B62W100 Series
 - 2nd Coat: Tile-Clad II Epoxy, B62W100 Series
(9 mils wet, 4 mils dry per coat)
4. GYPSUM WALLBOARD
 - A. Painted (Eg-Shel Finish/Latex Base)
 - 1st Coat: ProMar 200 Latex Wall Primer, B28W200
 - 2nd Coat: ProMar 200 Alkyd Eg-Shel Enamel, B33W200
 - 3rd Coat: ProMar 200 Alkyd Eg-Shel Enamel, B33W200
5. FERROUS METAL (Gloss, Handrails)
 - A. Painted (Gloss Finish/Alkyd Base)
 - 1st Coat: Kem Kromik Metal Primer, B50N2/B50W1
 - 2nd Coat: Industrial Enamel, B54 Series
 - 3rd Coat: Industrial Enamel, B54 Series
6. GALVANIZED METAL
 - A. Painted (Flat Finish/Latex Base)
 - 1st Coat: ProMar 200 Latex Flat Wall Paint, B30W200
 - 2nd Coat: ProMar 200 Latex Flat Wall Paint, B30W200
7. ALUMINUM
 - A. Painted (Flat Finish/Latex Base)
 - 1st Coat: ProMar 200 Latex Flat Wall Paint, B30W200
 - 2nd Coat: ProMar 200 Latex Flat Wall Paint, B30W200
8. CONCRETE FLOORS (SEALED)
 - A. Painted (Clear Acrylic Floor Finish)
 - 1st Coat: Concrete and Terrazzo Sealer B44V22 or W.R. Meadows – TIAH

END OF SECTION 09900

SECTION 10431

SIGNAGE

PART 1 - GENERAL

1.1 RELATED DOCUMENTS

- A. Drawings and general provisions of the Contract, including General and Supplementary Conditions and Division 1 Specification Sections, apply to this Section.

1.2 SUMMARY

- A. This Section includes the following:
 1. Exterior ADA Parking Signs & Poles
 2. Signage for Building Numbering, Property Address, Unit Numbering, Office Hours & Phone Number, Clubhouse Room labels, Rent Drop Box, Fitness Room Rules, Required Exit Signage, etc.
 3. Monument Sign (front and back)

1.3 DEFINITIONS

- A. ADA-ABA Accessibility Guidelines: U.S. Architectural & Transportation Barriers Compliance Board's "Americans with Disabilities Act (ADA) Accessibility Guidelines for Buildings and Facilities; Architectural Barriers Act (ABA) Accessibility Guidelines."
- B. Exit Door/Stair Signage – Doors at exit passageways, exit discharge and exit stairs shall be identified by tactile signs complying with 2010 ADA Standards for Accessible Design Sections 703.1, 703.2 – 703.5

1.4 SUBMITTALS

- A. Product Data: For each type of product indicated.
- B. Shop Drawings: Show fabrication and installation details for signs.
 1. Show sign mounting heights, locations of supplementary supports to be provided by others, and accessories.
 2. Provide message list, typestyles, graphic elements, including tactile characters and Braille, and layout for each sign.
- C. Samples for Initial Selection: Manufacturer's color charts consisting of actual units or sections of units showing the full range of colors.
- D. Samples for Verification: For each of the following products and for the full range of color, texture, and sign material indicated, of sizes indicated:
 1. Plaque Casting: 6 inches (150 mm) square including border.
 2. Dimensional Characters: Full-size Samples of each type of dimensional character letter, number, and graphic element.
 3. Aluminum: For each form, finish, and color, on **6-inch- (150-mm-)** long sections of extrusions and squares of sheet at least **4 by 4 inches (100 by 100 mm)**.
- E. Sign Schedule: Use same designations indicated on Drawings.
- F. Maintenance Data: For signs to include in maintenance manuals.
- G. Warranty: Special warranty specified in this Section.

1.5 QUALITY ASSURANCE

- A. Fabricator Qualifications: Shop that employs skilled workers who custom-fabricate products similar to those required for this Project and whose products have a record of successful in-service performance.
- B. Source Limitations for Signs: Obtain each sign type indicated from one source from a single manufacturer.
- C. Regulatory Requirements: Comply with applicable provisions in ADA-ABA Accessibility Guidelines and ICC/ANSI A117.1.

- 1.6 PROJECT CONDITIONS
- A. Weather Limitations: Proceed with installation only when existing and forecasted weather conditions permit installation of signs in exterior locations to be performed according to manufacturers' written instructions and warranty requirements.
 - B. Field Measurements: Verify recess openings by field measurements before fabrication and indicate measurements on Shop Drawings.
- 1.7 COORDINATION
- A. Coordinate placement of anchorage devices with templates for installing signs.
- 1.8 WARRANTY
- A. Special Warranty: Manufacturer's standard form in which manufacturer agrees to repair or replace components of signs that fail in materials or workmanship within specified warranty period.
 - 1. Failures include, but are not limited to, the following:
 - a. Deterioration of metal and polymer finishes beyond normal weathering.
 - b. Deterioration of embedded graphic image colors and sign lamination.
 - 2. Warranty Period: **Five** years from date of Substantial Completion.

PART 2 - PRODUCTS

- 2.1 MATERIALS
- A. Aluminum Sheet and Plate: **ASTM B 209 (ASTM B 209M)**, alloy and temper recommended by aluminum producer and finisher for type of use and finish indicated, and with at least the strength and durability properties of Alloy 5005-H32.
 - B. Rooms, Offices & Restroom - Tactile and Braille Signage: **Per Allowance**, Manufacturer's standard process for producing text and symbols complying with ADA-ABA Accessibility Guidelines and with ICC/ANSI A117.1. Text shall be accompanied by Grade 2 Braille. Produce precisely formed characters with square-cut edges free from burrs and cut marks; Braille dots with domed or rounded shape.
 - 1. Panel Material: **Opaque acrylic sheet.**
 - 2. Raised-Copy Thickness: Not less than **1/32 inch (0.8 mm)**.
- 2.2 ACCESSORIES
- A. Anchors and Inserts: Provide nonferrous-metal or hot-dip galvanized anchors and inserts for exterior installations and elsewhere as required for corrosion resistance. Use toothed steel or lead expansion-bolt devices for drilled-in-place anchors. Furnish inserts, as required, to be set into concrete or masonry work.
- 2.3 FABRICATION
- A. General: Provide manufacturer's standard signs of configurations indicated.
 - 1. Welded Connections: Comply with AWS standards for recommended practices in shop welding. Provide welds behind finished surfaces without distortion or discoloration of exposed side. Clean exposed welded surfaces of welding flux and dress exposed and contact surfaces.
 - 2. Mill joints to tight, hairline fit. Form joints exposed to weather to exclude water penetration.
 - 3. Preassemble signs in the shop to greatest extent possible. Disassemble signs only as necessary for shipping and handling limitations. Clearly mark units for reassembly and installation, in location not exposed to view after final assembly.
 - 4. Conceal fasteners if possible; otherwise, locate fasteners where they will be inconspicuous.
- 2.4 FINISHES, GENERAL
- A. Comply with NAAMM's "Metal Finishes Manual for Architectural and Metal Products" for recommendations for applying and designating finishes.
 - B. Protect mechanical finishes on exposed surfaces from damage by applying a strippable, temporary protective covering before shipping.
 - C. Appearance of Finished Work: Variations in appearance of abutting or adjacent pieces are acceptable if they are within one-half of the range of approved Samples. Noticeable variations in the same piece are not acceptable. Variations in appearance of other components are acceptable if they are within the range of approved Samples and are assembled or installed to minimize contrast.

2.5 ACRYLIC SHEET FINISHES

- A. Colored Coatings for Acrylic Sheet: For copy **and background** colors, provide colored coatings, including inks, dyes, and paints, that are recommended by acrylic manufacturers for optimum adherence to acrylic surface and that are UV and water resistant for **three** years for application intended.

PART 3 - EXECUTION

3.1 EXAMINATION

- A. Examine substrates, areas, and conditions, with Installer present, for compliance with requirements for installation tolerances and other conditions affecting performance of work.
- B. Verify that items, **including anchor inserts** are sized and located to accommodate signs.
- C. Proceed with installation only after unsatisfactory conditions have been corrected.

3.2 INSTALLATION

- A. Locate signs and accessories where indicated, using mounting methods of types described and complying with manufacturer's written instructions.
 - 1. Install signs level, plumb, and at heights indicated, with sign surfaces free of distortion and other defects in appearance.
 - 2. Interior Wall Signs: Install signs on walls adjacent to latch side of door where applicable. Where not indicated or possible, such as double doors, install signs on nearest adjacent walls. Locate to allow approach within **3 inches (75 mm)** of sign without encountering protruding objects or standing within swing of door.

3.3 CLEANING AND PROTECTION

- A. After installation, clean soiled sign surfaces according to manufacturer's written instructions. Protect signs from damage until acceptance by Owner.

END OF SECTION 10431

SECTION 10522

FIRE EXTINGUISHERS, CABINETS, AND ACCESSORIES

PART 1 GENERAL

1.01 SECTION INCLUDES

- A. Fire extinguishers; Reference drawings
 - Cabinets with Extinguishers, where indicated on the floor plans. (1 total)
 - Wall Mtd Extinguishers, 1 at each apartment unit. (42 Total)

1.02 SUBMITTALS

- A. Product Data: Provide extinguisher operational features, color and finish, and anchorage details.
- B. Manufacturer's Installation Instructions: Indicate special criteria and wall opening coordination requirements.

PART 2 PRODUCTS

2.01 MANUFACTURERS

- A. LARSEN'S - Architectural Series 2409-R3 & FS 2409-R3, Vertical Duo Door, baked enamel interior finish. Fire rated cabinets, FS where indicated to be installed in fire rated assemblies, Ref. CFP sheet.
- B. Substitutions: Under provisions of the General Requirements.

2.02 EXTINGUISHERS

- A. Dry Chemical Type: Larsen's MP series MP5, Cast steel tank, with pressure gage.

2.03 CABINETS

- A. Interior Metal: Formed sheet steel, baked enamel box.
- B. Configuration: Semi-recessed type, exterior nominal dimensions of 27 1/2 inch high x 13 inch wide x 5 inch deep.
- C. Trim Type: Returned to wall surface, with 2 1/2 inch projection.
- D. Exterior Door and Trim: Stainless Steel, reinforced for flatness and rigidity; latch with vertical glass.
- E. Door Glazing: Glass, clear, 1/8 inch thick tempered.
- F. Cabinet Mounting Hardware: Appropriate to cabinet.

2.04 FABRICATION

- A. Form cabinet enclosure with right angle inside corners and seams. Formed trim and door stiles.
- B. Pre-drill for anchors.
- C. Hinge doors for 180 degree opening with continuous piano hinge. Provide roller type catch.
- D. Weld, fill, and grind components smooth.
- E. Glaze doors with resilient channel gasket glazing.

PART 3 EXECUTION

3.01 EXAMINATION

- A. Verify rough openings for cabinet are correctly sized and located.

3.02 INSTALLATION

- A. Install in accordance with manufacturer's instructions.
- B. Install cabinets plumb and level in wall openings, 24 inches from finished floor to inside bottom of cabinet.
- C. Secure rigidly in place.
- D. Place extinguishers in cabinets.
- E. Verify exact location with Architect.

END OF SECTION 10522

SECTION 10800

TOILET AND BATH ACCESSORIES

PART 1 GENERAL

1.01 SECTION INCLUDES

- A. Toilet and washroom accessories.
- B. Grab bars, Towel bars
- C. Mirrors
- D. Toilet Paper, Paper Towel
- E. Attachment hardware

PART 2 PRODUCTS

2.01 MANUFACTURERS

- A. BOBRICK WASHROOM EQUIPMENT INC., or BRADLEY CORPORATION.
- B. Substitutions: Under provisions of the General Requirements.

2.02 FABRICATION

- A. Weld and grind joints of fabricated components, smooth.
- B. Form exposed surfaces from single sheet of stock, free of joints. Form surfaces flat without distortion. Maintain surfaces without scratches or dents.
- C. Fabricate grab bars of tubing, free of visible joints, return to wall with end attachment flanges. Form bar with 1 1/2 inches clear of wall surface. Knurl grip surfaces.
- D. Shop assemble components and package complete with anchors and fittings.
- E. Provide steel anchor plates, adapters, and anchor components for installation.

2.03 FINISHES

- A. Galvanizing: ASTM A123 to 1.25 oz./sq. yd. Galvanize ferrous metal and fastening devices.
- B. Chrome/Nickel Plating: ASTM B456, satin finish.
- C. Stainless Steel: No. 4 satin luster finish.
- D. Back paint components where contact is made with building finishes to prevent electrolysis.

PART 3 EXECUTION

3.01 EXAMINATION

- A. Verify that site conditions are ready to receive work and dimensions are as indicated on shop drawings and instructed by the manufacturer.
- B. Verify exact location of accessories for installation. Coordinate with ADA requirements.

3.02 PREPARATION

- A. Deliver inserts and rough-in frames to site for timely installation. Provide templates and rough-in measurements as required.

3.03 INSTALLATION

- A. Install accessories in accordance with manufacturer's instructions and Americans with Disabilities Act. Also reference ANSI A117.1.
- B. Install plumb and level, securely and rigidly anchored to substrate.
- C. At 2 Bedroom and 3 Bedroom adaptable and accessible units, Master Bath, install blocking for future grab bars.

3.04 SCHEDULE

- A. Reference drawings for all required accessories and submit for approval including but not limited to:
- B. Toilet Tissue Holders: Bobrick.
- C. Towel Disp/Waste Recep. : Bobrick
- D. Towel Bar: (2 per bathroom) 24" & 18" with concealed wall bracket. (reference plans)
- E. Grab Bars as indicated on the drawings, Bobrick.
- F. Shower Curtain Rod: Stainless Steel Tube, 1 inch O.D., concealed attachment.

END OF SECTION 10800

SECTION 10850

BUILDING SPECIALTIES

PART 1 GENERAL

1.1 SECTION INCLUDES

- A. Building specialties shall be furnished and installed as shown and herein specified. Installation shall be in accordance with the respective manufacturer's instructions. Certain manufacturer's products have been selected as a basic standard, and reference to these products has been made. Other manufacturers' products of equal capacities and design characteristics may be used, if approved by the Architect prior to the Bidding. The Contractor shall submit for approval shop drawings or standard cuts and illustrations or a combination thereof showing all items he proposes to use.

1.2 PLAYGROUND SURFACING & EQUIPMENT

- A. Edging – 'Parkurb' border from www.playgroundequipment.com. Should be dug into the ground so that top of edging is flush with sidewalk and mulch surface to meet Accessibility requirements. Color to be selected by Architect
- B. Mulch – 'Playsafer Rubber mulch' frame www.rubbercycle.com. Depth and installation to meet ASTM F 1292-99/04, ASTM F 1487-01, ASTM F 1951-99, Per Manufacturer recommendations. Color to be selected by Architect
- C. Equipment (Reference Sheet A1.2 for more details)
 - 1. **Custom Play-Gym** – (1) Total. By Superior Playgrounds. Should include 4 play components. Suitable for ages 2-5. Color scheme to be selected by Architect
- D. Benches – (1) Total – Polywood Traditional Garden 60" Bench. Color to be selected by Architect

1.3 MAILBOXES

- A. Manufacturer – Florence Manufacturing Company, (2) 4C12D-22CS, and (2) 4C16D-6P, front loading horizontal mailboxes for recessed mounting with snap-on outer trim kit.
- B. Additional Features: Standard 5-pin cylinder tenant cam lock with two keys. Engraved identification number for slots with color fill. Owner to select color of all finishes.
- C. Quantity, layout and Size: Reference Sheets on Sheet A1.4

1.4 BBQ – PICNIC AREA

- A. Picnic Tables – (2) Total – www.theparkcatalog.com Everest Series, (1) 6'-0" Heavy Duty Picnic Table and (1) 8'-0" Heavy Duty ADA Single Sided Picnic Table. Colors to be selected by Architect
- B. BBQ Grill – (2) Total – MHP Propane Gas Grill with Stainless Steel Shelves and Stainless Grids on in-ground Post. Mounted to meet ADA requirements. www.bbquguys.com

1.5 BIKE RACK

- A. Bike Racks – (2) Total – 5 bike Sonic Wave Rack (www.theparkcatalog.com) Color to be selected by Architect

1.6 CLOSET SHELVING

- A. Reference floors for location and installation height.
- B. Easy to adjust system (without use of tools)
- C. Manufacturers: **Organized Living, Freedom Rail** or approved equal.
 - 1. Color: White
 - 2. Components: Rails, Rod Stop, Clothes Rod, Ventilated Shelves, Brackets, Mounting hardware
 - 3. Hanging rail mounted to wall per manufacturer's instructions: uprights spaced 36 inches apart to support 50 pounds.

END OF SECTION 10850

10850-1

Building Specialties

SECTION 11451
RESIDENTIAL APPLIANCES

PART 1 - GENERAL

1.1 RELATED DOCUMENTS

- A. Drawings and general provisions of the Contract, including General and Supplementary Conditions and Division 1 Specification Sections, apply to this Section.

1.2 SUMMARY

- A. This Section includes the following:
1. Electric ranges
 2. Microwave ovens, Over-the-range and Countertop
 3. Ventilation range hoods
 4. Refrigerator/freezers; **Energy Star Compliant.**
 5. Dishwashers; **Energy Star Compliant.**
 6. Garbage Disposal; **Energy Star Compliant**
 7. Clothes Washers & Dryers; **Energy Star Compliant**

1.3 SUBMITTALS

- A. Product Data: For each type of product indicated. Include operating characteristics, dimensions of individual appliances, and finishes for each appliance. **All appliances must be submitted and approved by the Owner/Architect prior to ordering.**
- B. Samples for Verification: factory-applied **color** finishes.
- C. Appliance Schedule: For appliances; use same designations indicated on Drawings.
- D. Manufacturer Certificates: Signed by manufacturers certifying that products comply with requirements.
- E. Product Test Reports: Based on evaluation of comprehensive tests performed by manufacturer and witnessed by a qualified testing agency, for **each product.**
- F. Maintenance Data: For **each product** to include in maintenance manuals.
- G. Warranties: Special warranties specified in this Section.

1.4 QUALITY ASSURANCE

- A. Manufacturer Qualifications: A qualified manufacturer with a service center capable of providing training, parts, and emergency maintenance repairs.
- B. Product Options: Information on Drawings and in Specifications establishes requirements for product's aesthetic effects and performance characteristics. Aesthetic effects are indicated by dimensions, arrangements, alignment, and profiles of components and assemblies as they relate to sightlines, to one another, and to adjoining construction. Performance characteristics are indicated by criteria subject to verification by one or more methods including preconstruction testing, field testing, and in-service performance.
- C. Regulatory Requirements: Comply with provisions of the following product certifications:
1. NFPA: Provide electrical appliances listed and labeled as defined in NFPA 70, Article 100, by a testing agency acceptable to authorities having jurisdiction, and marked for intended use.
 2. UL and NEMA: Provide electrical components required as part of residential appliances that are listed and labeled by UL and that comply with applicable NEMA standards.
 3. ANSI: Provide gas-burning appliances that comply with ANSI Z21 Series standards.
 4. NAECA: Provide residential appliances that comply with NAECA standards.
- D. Regulatory Requirements, Accessibility: Where residential appliances are indicated to comply with accessibility requirements, comply with the U.S. Architectural & Transportation Barriers Compliance Board's "Americans with Disabilities Act (ADA), Accessibility Guidelines for Buildings and Facilities (ADAAG)." ANSI A117.1. FED-STD-795, "Uniform Federal Accessibility Standards."
1. Operable Parts: Provide controls with forward reach no higher than 48 inches (1219 mm) above the floor, horizontal front reach no more than 25 inches (635 mm), horizontal side reach no more than 24 inches (610 mm), and that do not require tight grasping, pinching, or twisting of the wrist and that operate with a force of not more than 5 lbf (22.2 N).
 2. Range or Cooktop: Provide knee clearance for forward approach of 27 inches (685 mm) high, 30 inches (760 mm) wide, and 11 inches (280 mm) horizontally; toe space clearance of 9 inches (230 mm) high and 17 inches (430 mm) horizontally; with insulated underside of cooktop to prevent burns, shocks, or abrasions. Provide top surface 34 inches (865 mm) above the floor, with controls that do not require reaching across burners.

3. Refrigerator/Freezer: Provide 50 percent of freezer space within 54 inches (1370 mm) of the floor.
- E. AHAM Standards: Provide appliances that comply with the following AHAM standards:
1. Dishwashers: AHAM DW-DW1.
 2. Electric Ranges: AHAM ER-1.
 3. Clothes Dryers: AHAM HLD-1.
 4. Household Refrigerators: AHAM HRF-1.
 5. Household Freezers: AHAM HRF-1.
 6. Trash Compactors: AHAM TC-1.
- F. Energy Ratings: Provide residential appliances that carry labels indicating energy-cost analysis (estimated annual operating costs) and efficiency information as required by the FTC Appliance Labeling Rule.
1. Provide appliances that qualify for the EPA/DOE ENERGY STAR product labeling program.
- G. Preinstallation Conference: Conduct conference at Project site to comply with requirements in Division 1 Section "Project Management and Coordination."
- 1.5 WARRANTY
- A. Special Warranties: Manufacturer's standard form in which manufacturer of each appliance specified agrees to repair or replace residential appliances or components that fail in materials or workmanship within specified warranty period.
1. Electric Range: 5-year limited warranty for surface-burner elements.
 2. Microwave Oven: 5-year limited warranty for defects in the magnetron tube.
 3. Refrigerator/Freezer: 5-year limited warranty for in-home service on the sealed refrigeration system.
 4. Freezer: 5-year limited warranty for in-home service on the sealed refrigeration system.
 5. Dishwasher: 5-year warranty for in-home service against deterioration of tub and door liner.
 6. Clothes Washer: 5-year limited warranty for the inner wash basket and outer tub, and 5-year limited warranty for the balance suspension system and drive transmission.

PART 2 - PRODUCTS

2.1 MANUFACTURERS

- A. In other Part 2 articles where titles below introduce lists, the following requirements apply to product selection:
1. Available Products: Subject to compliance with requirements, products that may be incorporated into the Work include, but are not limited to, products specified.
 2. Products: Subject to compliance with requirements, provide one of the products specified.
 3. Basis-of-Design Product: The design for each residential appliance is based on the product named. Subject to compliance with requirements, provide either the named product or a comparable product by one of the other manufacturers specified.
 4. **All appliances & finishes must be submitted and approved by the Owner/Architect prior to ordering.**
 5. **Confirm selected or submitted appliances fit in the designed space with manufacturers listed or recommended clearances.**
- 2.2 COOKING APPLIANCES, provide one at each unit and clubhouse as indicated.
- A. Range, **Black**
1. Products: 30" Free Standing Range
 2. Accessible Units to be ADA compliant range with front controls
 3. Acceptable manufacturers, submit equals for approval.
 - a. Amana Appliances, General Electric Company; Hotpoint; KitchenAid, Maytag
- B. Microwave Oven, Over-the-Range, **Black**
1. Products: Over Range Microwave Oven 1.5 cf, 950 watt,
 2. Acceptable manufacturers, submit equals for approval.
 - a. Amana Appliances; General Electric Company; Hotpoint; KitchenAid; Maytag;
- C. Microwave Oven, Countertop, **Black**
1. Products: Microwave Oven .7 cf, 700 watt,
 2. Acceptable manufacturers, submit equals for approval.
 - a. Amana Appliances; General Electric Company; Hotpoint; KitchenAid; Maytag;

- D. Exhaust Hood, **Black**
 - 1. Products: Standard Range Hood, 30" wide
 - 2. Controls must be accessible via switches (complying with accessible reach-range heights) above countertop.
 - 3. Acceptable manufacturers, submit equals for approval.
 - a. General Electric Company; Hotpoint; KitchenAid; Maytag; Whirlpool Corp
- 2.3 REFRIGERATION APPLIANCES, provide one at each unit and clubhouse as indicated.
 - A. Refrigerator/Freezer w ice maker, **Black**
 - 1. Products: Top-Freezer Refrigerator, **Energy Star Rated**, 17.5 Cu.Ft. min., 30" wide max.
 - 2. Accessible Units to have ADA compliant refrigerators with easy operation and access required by the Americans with Disabilities Act
 - 3. Acceptable manufacturers, submit equals for approval.
 - a. Amana Appliances; General Electric Company; Hotpoint; KitchenAid; Maytag;
- 2.4 CLEANING APPLIANCES, provide one at each unit and clubhouse as indicated.
 - A. Garbage Disposal – **Energy Star Rated**, Reference Mechanical drawings and schedules
 - B. Dishwasher, **Black**
 - 1. Products: Dishwasher, **Energy Star Rated**
 - 2. Accessible Units & Clubhouse to have ADA compliant dishwasher with low-profile installation made for 34" tall countertops.
 - 3. Acceptable manufacturers, submit equals for approval.
 - a. Amana Appliances; General Electric Company; Hotpoint; KitchenAid; Maytag;
 - C. Clothes Washer
 - 1. Products: Clothes Washer, White, **Energy Star Rated**
 - 2. Size: Must fit in Laundry Closets, 27" W x 30" D max.
 - 3. **Accessible Units (indicated on plan) to have ADA compliant frontload unit, controls on front.**
 - 4. Acceptable manufacturers, submit equals for approval.
 - a. Amana Appliances; General Electric Co; Hotpoint; KitchenAid; Maytag;
 - D. Clothes Dryer
 - 1. Products: Clothes Dryer, White, **Energy Star Rated**
 - 2. Size: Must fit in Laundry Closets, 27" W x 30" D max.
 - 3. **Accessible units (indicated on plan) to have ADA compliant frontload unit, controls on front.**
 - 4. Verify with plans for required Side exhaust
 - 5. Acceptable manufacturers, submit equals for approval.
 - a. Amana Appliances; General Electric Company; Hotpoint; KitchenAid; Maytag;
- 2.5 FINISHES, GENERAL
 - A. Comply with NAAMM's "Metal Finishes Manual for Architectural and Metal Products" for recommendations for applying and designating finishes.
 - B. Protect mechanical finishes on exposed surfaces from damage by applying a strippable, temporary protective covering before shipping.
 - C. Color-Coated Finish: Provide appliances with manufacturer's standard finish complying with manufacturer's written instructions for surface preparation including pretreatment, application, baking, color, gloss, and minimum dry film thickness for painted finishes
 - D. For exact finish, insert names of coating manufacturers and products.

PART 3 - EXECUTION

- 3.1 EXAMINATION
 - A. Examine roughing-in for piping systems to verify actual locations of piping connections before equipment installation.
 - B. Proceed with installation only after unsatisfactory conditions have been corrected.
- 3.2 INSTALLATION, GENERAL
 - A. General: Comply with manufacturer's written instructions.
 - B. Built-in Equipment: Securely anchor units to supporting cabinets or countertops with concealed fasteners. Verify that clearances are adequate for proper functioning and rough openings are completely concealed.
 - C. Freestanding Equipment: Place units in final locations after finishes have been completed in each area. Verify that clearances are adequate to properly operate equipment.
 - D. Utilities: Refer to Divisions 15 and 16 for plumbing and electrical requirements.

3.3 CLEANING AND PROTECTION

- A. Test each item of residential appliances to verify proper operation. Make necessary adjustments.
- B. Verify that accessories required have been furnished and installed.
- C. Remove packing material from residential appliances and leave units in clean condition, ready for operation.

3.4 DEMONSTRATION

- A. Engage a factory-authorized service representative to train Owner's maintenance personnel to adjust, operate, and maintain residential appliances. Refer to Division 1 Section "Demonstration and Training."

END OF SECTION 11451

SECTION 12356

KITCHEN CASEWORK

PART 1 - GENERAL

1.1 RELATED DOCUMENTS

- A. Drawings and general provisions of the Contract, including General and Supplementary Conditions and Division 1 Specification Sections, apply to this Section.

1.2 SUMMARY

- A. This Section includes the following:
 - 1. Wood-faced kitchen cabinets.
 - 2. Wood-faced vanity cabinets.
 - 3. Plastic-laminate countertops.
- B. Related Sections include the following:
 - 1. Division 11 Section "Residential Appliances" for appliances mounted in kitchen casework.
 - 2. Division 15 Section "Plumbing Fixtures" for sink units mounted in countertops.

1.3 DEFINITIONS

- A. Exposed Surfaces of Casework: Surfaces visible when doors and drawers are closed, including visible surfaces in open cabinets or behind glass doors.
- B. Semi-exposed Surfaces of Casework: Surfaces behind opaque doors or drawer fronts, including interior faces of doors and interiors and sides of drawers. Bottoms of wall cabinets are defined as "semi-exposed."
- C. Concealed Surfaces of Casework: Surfaces not usually visible after installation, including sleepers, web frames, dust panels, bottoms of drawers, and ends of cabinets installed directly against and completely concealed by walls or other cabinets. Tops of wall cabinets and utility cabinets are defined as "concealed."

1.4 SUBMITTALS

- A. Product Data: For the following:

Samples and Submittals must be approved by Owner/Developer prior to ordering or production.

- 1. Cabinets.
- 2. Plastic-laminate countertops.
- 3. Cabinet hardware.
- B. Shop Drawings: For cabinets and countertops. Include plans, elevations, details, and attachments to other work. Show materials, finishes, filler panels, hardware, edge and backsplash profiles, cutouts for plumbing fixtures, and methods of joining countertops.
- C. Samples for Initial Selection: Manufacturer's color samples consisting of units or sections of units showing the full range of colors, textures, and patterns available for each type of material exposed to view.
- D. Samples for Verification: For the following materials; in sets showing the full range of color, texture, and pattern variations expected:
 - 1. Wood-veneered panels with transparent finish, 8 by 10 inches (200 by 250 mm), for each species.
 - 2. Solid wood with transparent finish, 50 sq. in. (300 sq. cm), for each species.
 - 3. Plastic laminate for countertops, 8 by 10 inches (200 by 250 mm).
 - 4. One unit of each type of exposed hardware.
- E. Product Certificates: Signed by manufacturers of casework certifying that products furnished comply with requirements. **Samples and Submittals must be approved by Owner/Developer prior to ordering or production.**

1.5 QUALITY ASSURANCE

- A. Source Limitations for Cabinets: Obtain cabinets through one source from a single manufacturer.
- B. Product Designations: Drawings indicate size, configurations, and finish material of casework by referencing designated manufacturer's catalog numbers. Other manufacturers' casework of similar sizes, similar door and drawer configurations, same finish material, and complying with the Specifications may be considered. Refer to Division 1 Section "Substitutions."

- C. Quality Standards: Unless otherwise indicated, comply with the following standards:
 - 1. Cabinets: KCMA A161.1.
 - a. KCMA Certification: Provide cabinets with KCMA's "Certified Cabinet" seal affixed in a semi exposed location of each unit and showing compliance with the above standard.
 - b. Cabinets shall have no formaldehyde added during the manufacturing process.**
 - 2. Plastic-Laminate Countertops: KCMA A161.2.
- 1.6 PROJECT CONDITIONS
- A. Environmental Limitations: Do not deliver or install kitchen casework until building is enclosed, wet-work is complete, and HVAC system is operating and will maintain temperature and relative humidity at occupancy levels during the remainder of the construction period.
 - B. Established Dimensions: Where kitchen casework is indicated to fit to other construction, establish dimensions for areas where casework is to fit. Coordinate construction to ensure that actual dimensions correspond to established dimensions. Provide fillers and scribes to allow for trimming and fitting.
 - C. Field Measurements: Where kitchen casework is indicated to fit to existing construction, verify dimensions of existing construction by field measurements before fabrication and indicate measurements on Shop Drawings. Provide fillers and scribes if necessary.
 - D. Field Measurements for Countertops: Verify dimensions of countertops by field measurements after base cabinets are installed but before countertop fabrication is complete. Coordinate fabrication schedule with construction progress to avoid delaying the Work.
- 1.7 COORDINATION
- A. Coordinate layout and installation of blocking and reinforcement in partitions for support of kitchen casework.

PART 2 - PRODUCTS

2.1 MANUFACTURERS

- A. Available Manufacturers: Subject to compliance with requirements, manufacturers offering products that may be incorporated into the Work include, but are not limited to, the following:
- B. Manufacturers: Subject to compliance with requirements, provide products by one of the following:
 - 1. Cabinets:
 - a. Mid America Cabinets, Vista Box Style, Concord Door Style**
 - 1) Wood: Species and Stain to be selected by Architect from full range of colors and selections.
 - 2. Plastic Laminate for Countertops:
 - a. Formica Corp.
 - b. Nevamar Corp.
 - c. Pionite Plastics Corp.
 - d. WilsonArt

2.2 COLORS, TEXTURES, AND PATTERNS

- A. Colors, Textures, and Patterns: As listed, or selected by Architect from manufacturer's full range for these characteristics.

2.3 CABINET MATERIALS

- A. Exposed Materials: Comply with the following:
 - 1. Exposed Wood Species: As follows. Do not use two adjacent exposed faces that are noticeably dissimilar in color, grain, figure, or natural character markings.
 - 2. Solid Wood: Clear hardwood lumber of species indicated, free of defects, selected for compatible grain and color, and kiln dried to 7 percent moisture content.
 - 3. Plywood: Hardwood plywood complying with HPVA HP-1 with face veneer of species indicated, selected for compatible color and grain with Grade A faces and Grade C backs of same species as faces.
 - a. Edge band exposed edges with minimum **1/8-inch- (3-mm-)** thick, solid-wood edging of same species as face veneer.
- B. Semi exposed Materials: Unless otherwise indicated, provide the following:
 - 1. Plywood: Hardwood plywood complying with HPVA HP-1 with Grade C faces stained to be compatible with exposed surfaces and Grade 3 backs of same species as faces.

2. Thermoset Decorative Panels: Medium-density particleboard complying with ANSI A208.1, Grade M-2; with surface of thermally fused, melamine-impregnated decorative paper complying with LMA SAT-1.
 - a. Provide thermoset decorative overlay on both sides of shelves, dividers, drawer bodies, and other components with two semi exposed surfaces.
 - b. Provide PVC or polyester edge banding complying with LMA EDG-1 on components with semi exposed edges.
 3. Vinyl-Faced Particleboard: Medium-density particleboard complying with ANSI A208.1, Grade M-2 with an embossed, wood-grain-patterned vinyl film adhesively bonded to particleboard.
 - a. Provide vinyl film on both sides of shelves, dividers, drawer bodies, and other components with two semi exposed surfaces and on semi exposed edges.
 4. All cabinets and must be made with formaldehyde free materials.
- C. Concealed Materials: Comply with the following:
1. Particleboard: ANSI A208.1, Grade M-2.
 3. Medium-Density Fiberboard: ANSI A208.2.
 4. Hardboard: AHA A135.4, Class 1 Tempered.
 5. All cabinets and shelves must be made with formaldehyde free materials.
- D. ALL CABINETS: No formaldehyde shall be added during the manufacturing process.

2.4 COUNTERTOP MATERIALS

- A. Plastic Laminate: High-pressure decorative laminate complying with NEMA LD 3.
 1. Grade: HGS.
 2. Grade: HGP.
 3. Provide through-color plastic laminate.
 4. Grade for Backer Sheet: BKL.
- B. Particleboard: ANSI A208.1, Grade M-2.
- C. Plywood: Exterior softwood plywood complying with PS 1, Grade C-C Plugged, touch sanded.
- D. Solid Wood Edges and Trim: Clear hardwood lumber of species indicated, free of defects, selected for compatible grain and color, and kiln dried.
- E. All countertop must be made of formaldehyde free material.

2.5 CASEWORK HARDWARE

- A. General: Manufacturer's standard units complying with BHMA A156.9, of type, material, size, and finish as selected from manufacturer's standard choices.
- B. Hinges: **Semi-concealed, self-closing hinges.**
- D. Drawer Guides: 100 lb. rated epoxy-coated-metal, self-closing drawer guides; designed to prevent rebound when drawers are closed; with nylon-tired, ball-bearing rollers; and complying with BHMA A156.9, Type B05091.
- E. Cabinet Pulls: **Bar style or knob style. Submit samples for review/approval. Color to be selected from full range of manufacturer's standard colors. Wire pulls not acceptable.**

2.6 CABINET CONSTRUCTION

- A. Face Style: Reveal overlay; door and drawer faces partially cover cabinet body or face frames.
- B. Face Frames: 3/4-inch solid wood with glued mortise and tenon or doweled joints.
- C. Door and Drawer Fronts: 2 inch wide by 3/4 inch thick perimeter assembled around a 1/4 inch veneer panel.
- D. Cabinet Ends: 1/2 inch industrial-grade particle board fastened to face frame with tongue-and-groove. Exposed end panels are finished with wood veneer to match face frame finish.
- E. Cabinet Tops and Bottoms: Wall cabinets constructed of 1/4 inch hardboard dadoed into end panels and interlocked into hanging rails for strength. Base bottoms constructed similarly of 1/2 inch industrial-grade particle board.
- F. Hanging Rails: 3/4 inch by 2-1/2 inch hardwood on upper cabinets. 3/4 inch by 1 inch hardwood on base cabinets.
- G. Drawers: 7/16 inch industrial-grade particle board using full box construction with 1/8 inch hardboard bottoms. Drawer fronts constructed to match cabinet door material and style.
- H. Shelves: 1/2 inch industrial-grade particle board. Wall shelving adjustable up to 24" wide. Base cabinets feature 11 inch deep half-shelf.
- I. Toe Kick: 1/2 inch industrial-grade particle board fastened between end panels.

- J. Joinery: Rabbet backs flush into end panels and secure with concealed mechanical fasteners. Connect tops and bottoms of wall cabinets and bottoms and stretchers of base cabinets to ends and dividers with mechanical fasteners. Rabbet tops, bottoms, and backs into end panels.
 - K. Factory Finishing: To greatest extent possible, finish casework at factory. Defer only final touchup until after installation.
- 2.7 PLASTIC-LAMINATE COUNTERTOPS
- A. Configuration: Provide countertops with the following front, cove (intersection of top with backsplash), backsplash, and end-splash style:
 1. Front: Classic waterfall edge
 2. Cove: Cove molding (one-piece postformed laminate supported at junction of top and backsplash by wood cove molding).
 3. Backsplash: Curved or waterfall shape with scribe.
 - B. Plastic-Laminate Substrate: Particleboard not less than 3/4 inch (19 mm) thick.
 1. For countertops at sinks and lavatories, use phenolic-resin particleboard or exterior-grade plywood.
 2. Build up countertop thickness to 1-1/2 inches (38 mm) at front, back, and ends with additional layers of particleboard laminated to top.
 - C. Backer Sheet: Provide plastic-laminate backer sheet on underside of countertop substrate.
 - D. Paper Backing: Provide paper backing on underside of countertop substrate.

PART 3 - EXECUTION

3.1 INSTALLATION

- A. Install casework with no variations in flushness of adjoining surfaces; use concealed shims. Where casework abuts other finished work, scribe and cut for accurate fit. Provide filler strips, scribe strips, and moldings in finish to match casework face.
- B. Install casework without distortion so doors and drawers fit openings and are aligned. Complete installation of hardware and accessories as indicated.
- C. Install casework and countertop level and plumb to a tolerance of 1/8 inch in 8 feet (3 mm in 2.4 m).
- D. Fasten cabinets to adjacent units and to backing.
 1. Fasten wall cabinets through back, near top and bottom, at ends and not less than 24 inches (600 mm) o.c. with No. 10 wafer-head screws sized for 1-inch (25-mm) penetration into wood framing, blocking, or hanging strips.
 2. Fasten wall cabinets through back, near top and bottom, at ends and not less than 24 inches (600 mm) o.c., with toggle bolts through metal backing behind gypsum board.
- E. Fasten plastic-laminate countertops by screwing through corner blocks of base units into underside of countertop. Form seams using splines to align adjacent surfaces, and secure with glue and concealed clamping devices designed for this purpose.
- F. Fasten solid-surfacing-material countertops by screwing through corner blocks of base units into underside of countertop. Align adjacent surfaces, and form seams to comply with manufacturer's written instructions using adhesive in color to match countertop. Carefully dress joints smooth, remove surface scratches, and clean entire surface.

3.2 ADJUSTING AND CLEANING

- A. Adjust casework and hardware so doors and drawers are centered in openings and operate smoothly without warp or bind. Lubricate operating hardware as recommended by manufacturer.
- B. Clean casework on exposed and semi-exposed surfaces. Touch up factory-applied finishes to restore damaged or soiled areas.

END OF SECTION 12356

SECTION 12491

HORIZONTAL LOUVER BLINDS

PART 1 - GENERAL

1.1 SUMMARY

- A. This Section includes the following types of venetian blinds and accessories:
 - 1. 1" Mini blinds with vinyl louver slats, Cordless.

1.2 SUBMITTALS

- A. Product Data: For each type of product indicated. Include styles, material descriptions, construction details, dimensions of individual components and profiles, features, finishes, and operating instructions.
- B. Shop Drawings: Show location and extent of horizontal louver blinds. Include elevations, sections, details, and dimensions not shown in Product Data. Show installation details, mountings, attachments to other Work, operational clearances, and relationship to adjoining work.
- C. Samples for Initial Selection: For each colored component of each type of horizontal louver blind indicated.
 - 1. Include similar Samples of accessories involving color selection.
- D. Window Treatment Schedule: Include horizontal louver blinds in schedule using same room designations indicated on Drawings.
- E. Product Certificates: For each type of horizontal louver blind product, signed by product manufacturer.
- F. Product Test Reports: For each type of horizontal louver blind product.
- G. Maintenance Data: For horizontal louver blinds to include in maintenance manuals. Include the following:
 - 1. Methods for maintaining horizontal louver blinds and finishes.
 - 2. Precautions about cleaning materials and methods that could be detrimental to finishes and performance.
 - 3. Operating hardware.

1.3 QUALITY ASSURANCE

- A. Source Limitations: Obtain horizontal louver blinds through one source from a single manufacturer.
- B. Fire-Test-Response Characteristics: Provide horizontal louver blinds with the fire-test-response characteristics indicated, as determined by testing identical products per test method indicated below by UL or another testing and inspecting agency acceptable to authorities having jurisdiction:
 - 1. Flame-Resistance Ratings: Passes NFPA 701.
- C. Electrical Components, Devices, and Accessories: Listed and labeled as defined in NFPA 70, Article 100, by a testing agency acceptable to authorities having jurisdiction, and marked for intended use.
- D. Corded Window Covering Product Standard: Provide horizontal louver blinds complying with WCMA A 100.1.
- E. Year 2000 Compliant: Computer hardware and software shall be capable of accurately processing, providing, and receiving date data from, into, and between the twentieth and twenty-first centuries, including leap year calculations.
- F. Mockups: Build mockups to verify selections made under sample Submittals and to demonstrate aesthetic effects and qualities of materials and execution.
 - 1. Build mockups in the location and of the size indicated or, if not indicated, as directed by Architect.
 - 2. Approved mockups may become part of the completed Work if undisturbed at time of Substantial Completion.

1.4 DELIVERY, STORAGE, AND HANDLING

- A. Deliver blinds in factory packages, marked with manufacturer and product name, and location of installation using same room designations indicated on Drawings and in a window treatment schedule.

1.5 PROJECT CONDITIONS

- A. Environmental Limitations: Do not install horizontal louver blinds until construction and wet and dirty finish work in spaces, including painting, is complete and ambient temperature and humidity conditions are maintained at the levels indicated for Project when occupied for its intended use.

- B. Field Measurements: Where horizontal louver blinds are indicated to fit to other construction, verify dimensions of other construction by field measurements before fabrication and indicate measurements on Shop Drawings. Allow clearances for operable glazed units' operation hardware throughout the entire operating range. Notify Architect of discrepancies. Coordinate fabrication schedule with construction progress to avoid delaying the Work.

PART 2 - PRODUCTS

2.1 MANUFACTURERS

- A. Available Manufacturers: Subject to compliance with requirements, manufacturers offering products that may be incorporated into the Work include, but are not limited to, the following:
- B. Manufacturers: Subject to compliance with requirements, provide products by one of the following:
 - 1. Horizontal Louver Blinds, Aluminum Louver Slats:
 - a. Comfortex Window Fashions.
 - b. Hunter Douglas Window Fashions.
 - c. Levolor Contract; a Newell Company; Levolor.
 - d. Springs Window Fashions Division, Inc.; Bali.
 - e. Springs Window Fashions Division, Inc.; Graber.
 - f. Verosol USA, Inc.

2.2 HORIZONTAL LOUVER BLINDS, VINYL LOUVER SLATS

- A. Available Products: Subject to compliance with requirements, products that may be incorporated into the Work include, but are not limited to, the following:
- B. Louver Slats: Extruded PVC .0165" thick x .970" width with crown of .160". 75% opacity.
- C. Accessories including: Headrail, Bottomrail, Tape Roller Support, Tape Roller, Tilt Roller, Cordlock, Tilter, Anchors, Endcaps, Clips, Cords, Ladder, Supports, Brackets, Mounting Brackets, etc. Per manufacturer
- D. Color: White
- E. Lift Operation: **Manual, Cordless**; lift mechanism to hold blind at any position in ascending or descending travel.

PART 3 - EXECUTION

3.1 EXAMINATION

- A. Examine substrates, areas, and conditions, with Installer present, for compliance with requirements for installation tolerances, operational clearances, and other conditions affecting performance. Proceed with installation only after unsatisfactory conditions have been corrected.

3.2 HORIZONTAL LOUVER BLIND INSTALLATION

- A. Install blinds level and plumb and aligned with adjacent units according to manufacturer's written instructions, and located so exterior louver edges in any position are not closer than 1 inch to interior face of glass. Install intermediate support as required to prevent deflection in headrail. Allow clearances between adjacent blinds and for operating glazed opening's operation hardware, if any.
- B. Flush Mounted: Install blinds with louver edges flush with finish face of opening if slats are tilted open.
- C. Jamb Mounted: Install headrail flush with face of opening jamb and head.
- D. Head Mounted: Install headrail on face of opening head.
- E. Recessed: Install headrail concealed within blind pocket.
- F. Connections: Connect motorized operators to building electrical system.

3.3 ADJUSTING

- A. Adjust horizontal louver blinds to operate smoothly, easily, safely, and free from binding or malfunction throughout entire operational range.

3.4 CLEANING AND PROTECTION

- A. Clean blind surfaces after installation, according to manufacturer's written instructions.
- B. Provide final protection and maintain conditions, in a manner acceptable to manufacturer and installer, that ensure that horizontal louver blinds are without damage or deterioration at time of Substantial Completion.
- C. Replace damaged blinds that cannot be repaired, in a manner approved by Architect, before time of Substantial Completion.

END OF SECTION 12491

SECTION 133419

METAL CARPORT SYSTEM

PART 1 - GENERAL

1.1 SUMMARY

A. Section Includes:

1. **BAJA Construction, Co., Inc.** (925) 229-0161, or as approved equal. Full Cantilever Tapered type Carports, as indicated or implied on the construction documents.
2. Metal Carport Structural-steel framing, Metal roof panels, Trim and Flashings.

1.2 ACTION SUBMITTALS

A. Product Data: For each type of metal carport system component.

B. Shop Drawings: Indicate components by others. Include full building plan, elevations, sections, details, and attachments to other work. Signed and sealed by a qualified professional engineer Licensed in the State of Wyoming.

1.3 INFORMATIONAL SUBMITTALS

A. Letter of Design Certification: Signed and sealed by a qualified professional engineer. Include the following:

1. Name and location of Project.
2. Order number.
3. Name of manufacturer.
4. Name of Contractor.
5. Building dimensions including width, length, height, and roof slope.
6. Indicate compliance with AISC standards for hot-rolled steel and AISI standards for cold-rolled steel, including edition dates of each standard.
7. Governing building code and year of edition.
8. Design Loads: Include dead load, roof live load, collateral loads, roof snow load, deflection, wind loads/speeds and exposure, seismic design category or effective peak velocity-related acceleration/peak acceleration, and auxiliary loads (cranes).
9. Load Combinations: Indicate that loads were applied acting simultaneously with concentrated loads, according to governing building code.

B. Sample warranties.

1.4 CLOSEOUT SUBMITTALS

A. Maintenance data.

1.5 QUALITY ASSURANCE

A. Manufacturer Qualifications: A qualified manufacturer.

1. Engineering Responsibility: Preparation of comprehensive engineering analysis and Shop Drawings stamped and sealed by a professional engineer who is legally qualified to practice in Arlington Texas, where Project is located.

B. Erector Qualifications: An experienced erector who specializes in erecting and installing work similar in material, design, and extent to that indicated for this Project and who is acceptable to manufacturer.

1.6 WARRANTY

- A. Special Warranty on Metal Panel Finishes: Manufacturer agrees to repair finish or replace metal panels that show evidence of deterioration of factory-applied finishes within specified warranty period.
 - 1. Finish Warranty Period: **25** years from date of Substantial Completion.

PART 2 - PRODUCTS

2.1 MANUFACTURERS

- A. **BAJA Construction, Co., Inc.** (925) 229-0161, or as approved equal. Full Cantilever Tapered type Carports, as indicated or implied on the construction documents.

2.2 PERFORMANCE REQUIREMENTS

- A. Structural Performance: Metal carport systems shall withstand the effects of gravity loads and the following loads and stresses within limits and under conditions indicated according to IBC 2009 Design Loads and Local regulations for Arlington, Texas.
- B. Thermal Movements: Allow for thermal movements from ambient and surface temperature changes by preventing buckling, opening of joints, overstressing of components, failure of joint sealants, failure of connections, and other detrimental effects. Base calculations on surface temperatures of materials due to both solar heat gain and nighttime-sky heat loss.
- C. Structural Performance for Metal Roof Panels: Provide metal panel systems capable of withstanding the effects of the following loads, based on testing according to ASTM E 1592:

2.3 STRUCTURAL-STEEL FRAMING

- A. Structural Steel: Comply with AISC 360, "Specification for Structural Steel Buildings."
- B. Bolted Connections: Comply with RCSC's "Specification for Structural Joints Using High-Strength Bolts."
- C. Cold-Formed Steel: Comply with AISI's "North American Specification for the Design of Cold-Formed Steel Structural Members" for design requirements and allowable stresses.
- D. Primary Framing: Manufacturer's standard primary-framing system, designed to withstand required loads and specified requirements. Primary framing includes transverse and lean-to frames; rafters and rake beams; sidewall, intermediate, end-wall, and corner columns; and wind bracing.

2.4 FABRICATION

- A. General: Design components and field connections required for erection to permit easy assembly.
 - 1. Mark each piece and part of the assembly to correspond with previously prepared erection drawings, diagrams, and instruction manuals.
 - 2. Fabricate structural framing to produce clean, smooth cuts and bends. Punch holes of proper size, shape, and location. Members shall be free of cracks, tears, and ruptures.
- B. Tolerances: Comply with MBMA's "Metal Building Systems Manual" for fabrication and erection tolerances.
- C. Primary Framing: Shop fabricate framing components to indicated size and section, with baseplates, bearing plates, stiffeners, and other items required for erection welded into place. Cut, form, punch, drill, and weld framing for bolted field assembly.
- D. Secondary Framing: Shop fabricate framing components to indicated size and section by roll forming or break forming, with baseplates, bearing plates, stiffeners, and other plates required for erection welded into place. Cut, form, punch, drill, and weld secondary framing for bolted field connections to primary framing.
- E. Metal Panels: Fabricate and finish metal panels at the factory to greatest extent possible, by manufacturer's standard procedures and processes, as necessary to fulfill indicated performance requirements. Comply with indicated profiles and with dimensional and structural requirements.

PART 3 - EXECUTION

3.1 ERECTION OF STRUCTURAL FRAMING

- A. Erect metal carport system according to manufacturer's written instructions and drawings.
- B. Do not field cut, drill, or alter structural members without written approval from metal carport system manufacturer's professional engineer.
- C. Set structural framing accurately in locations and to elevations indicated, according to AISC specifications referenced in this Section. Maintain structural stability of frame during erection.
- D. Base and Bearing Plates: Clean concrete- and masonry-bearing surfaces of bond-reducing materials, and roughen surfaces prior to setting plates. Clean bottom surface of plates.
 - 1. Set plates for structural members on wedges, shims, or setting nuts as required.
 - 2. Tighten anchor rods after supported members have been positioned and plumbed. Do not remove wedges or shims but, if protruding, cut off flush with edge of plate before packing with grout.
 - 3. Promptly pack grout solidly between bearing surfaces and plates so no voids remain. Neatly finish exposed surfaces; protect grout and allow to cure. Comply with manufacturer's written installation instructions for shrinkage-resistant grouts.
- E. Align and adjust structural framing before permanently fastening. Before assembly, clean bearing surfaces and other surfaces that will be in permanent contact with framing. Perform necessary adjustments to compensate for discrepancies in elevations and alignment.
 - 1. Level and plumb individual members of structure.
 - 2. Make allowances for difference between temperature at time of erection and mean temperature when structure will be completed and in service.

3.2 METAL ROOF PANEL INSTALLATION

- A. General: Provide metal roof panels of full length from eave to ridge unless otherwise indicated or restricted by shipping limitations.
 - 1. Install ridge caps as metal roof panel work proceeds.
 - 2. Flash and seal metal roof panels with weather closures at eaves and rakes. Fasten with self-tapping screws.
- B. Lap-Seam Metal Roof Panels: Fasten metal roof panels to supports with exposed fasteners at each lapped joint, at location and spacing recommended by manufacturer.
 - 1. Provide metal-backed sealing washers under heads of exposed fasteners bearing on weather side of metal roof panels.
 - 2. Provide sealant tape at lapped joints of metal roof panels and between panels and protruding equipment, vents, and accessories.
 - 3. Apply a continuous ribbon of sealant tape to weather-side surface of fastenings on end laps and on side laps of nesting-type metal panels, on side laps of ribbed or fluted metal panels, and elsewhere as needed to make metal panels weatherproof to driving rains.
 - 4. At metal panel splices, nest panels with minimum **6-inch (152-mm)** end lap, sealed with butyl-rubber sealant and fastened together by interlocking clamping plates.
- C. Metal Fascia Panels: Align bottom of metal panels and fasten with blind rivets, bolts, or self-drilling or self-tapping screws. Flash and seal metal panels with weather closures where fasciae meet soffits, along lower panel edges, and at perimeter of all openings.

3.3 ACCESSORY INSTALLATION

- A. General: Install accessories with positive anchorage to building and weathertight mounting, and provide for thermal expansion. Coordinate installation with flashings and other components.
 - 1. Install components required for a complete metal roof panel assembly, including trim, copings, ridge closures, seam covers, flashings, sealants, gaskets, fillers, closure strips, and similar items.
 - 2. Install components for a complete metal wall panel assembly, including trim, copings, corners, seam covers, flashings, sealants, gaskets, fillers, closure strips, and similar items.

3. Where dissimilar metals contact each other or corrosive substrates, protect against galvanic action by painting contact surfaces with corrosion-resistant coating, by applying rubberized-asphalt underlayment to each contact surface, or by other permanent separation as recommended by manufacturer.
- B. Flashing and Trim: Comply with performance requirements, manufacturer's written installation instructions, and SMACNA's "Architectural Sheet Metal Manual." Provide concealed fasteners where possible, and set units true to line and level. Install work with laps, joints, and seams that will be permanently watertight and weather resistant.
1. Install exposed flashing and trim that is without excessive oil-canning, buckling, and tool marks and that is true to line and levels indicated, with exposed edges folded back to form hems. Install sheet metal flashing and trim to fit substrates and to result in waterproof and weather-resistant performance.
 2. Expansion Provisions: Provide for thermal expansion of exposed flashing and trim. Space movement joints at a maximum of **10 feet (3 m)** with no joints allowed within **24 inches (600 mm)** of corner or intersection. Where lapped or bayonet-type expansion provisions cannot be used or would not be sufficiently weather resistant and waterproof, form expansion joints of intermeshing hooked flanges, not less than **1 inch (25 mm)** deep, filled with mastic sealant (concealed within joints).

END OF SECTION 133419

SECTION 210500
COMMON WORK RESULTS FOR FIRE SUPPRESSION

PART 1 GENERAL

1.1 SECTION INCLUDES

- A. Pipe, fittings, valves, and connections for sprinkler systems.

1.2 RELATED REQUIREMENTS

- A. Section 078400 - Firestopping.
- B. Section 211300 - Fire-Suppression Sprinkler Systems: Sprinkler systems design.

1.3 REFERENCE STANDARDS

- A. ASME A112.18.1 - Plumbing Supply Fittings; 2012.
- B. ASME BPVC-IX - Boiler and Pressure Vessel Code, Section IX - Welding, Brazing, and Fusing Qualifications; 2015.
- C. ASME B16.1 - Gray Iron Pipe Flanges and Flanged Fittings: Classes 25, 125, and 250; 2010.
- D. ASME B16.3 - Malleable Iron Threaded Fittings: Classes 150 and 300; 2011.
- E. ASME B16.4 - Gray Iron Threaded Fittings: Classes 125 and 250; 2011.
- F. ASME B16.5 - Pipe Flanges and Flanged Fittings NPS 1/2 Through NPS 24 Metric/Inch Standard; 2013.
- G. ASME B16.9 - Factory-Made Wrought Buttwelding Fittings; 2012.
- H. ASME B16.11 - Forged Fittings, Socket-welding and Threaded; 2011.
- I. ASME B16.25 - Buttwelding Ends; 2012.
- J. ASME B36.10M - Welded and Seamless Wrought Steel Pipe; 2004.
- K. ASTM A47/A47M - Standard Specification for Ferritic Malleable Iron Castings; 1999 (Reapproved 2014).
- L. ASTM A53/A53M - Standard Specification for Pipe, Steel, Black and Hot-Dipped, Zinc-Coated, Welded and Seamless; 2012.
- M. ASTM A135/A135M - Standard Specification for Electric-Resistance-Welded Steel Pipe; 2009 (Reapproved 2014).
- N. ASTM A234/A234M - Standard Specification for Piping Fittings of Wrought Carbon Steel and Alloy Steel for Moderate and High Temperature Service; 2015.
- O. ASTM A536 - Standard Specification for Ductile Iron Castings; 1984 (Reapproved 2014).
- P. ASTM A795/A795M - Standard Specification for Black and Hot-Dipped Zinc-Coated (Galvanized) Welded and Seamless Steel Pipe for Fire Protection Use; 2013.
- Q. ASTM C592 - Standard Specification for Mineral Fiber Blanket Insulation and Blanket-Type Pipe Insulation (Metal-Mesh Covered) (Industrial Type); 2013.
- R. ASTM E814 - Standard Test Method for Fire Tests of Through-Penetration Fire Stops; 2013a.
- S. ASTM F438 - Standard Specification for Socket-Type Chlorinated Poly(Vinyl Chloride) (CPVC) Plastic Pipe Fittings, Schedule 40; 2015.
- T. ASTM F439 - Standard Specification for Chlorinated Poly(Vinyl Chloride) (CPVC) Plastic Pipe Fittings, Schedule 80; 2013.
- U. ASTM F442/F442M - Standard Specification for Chlorinated Poly(Vinyl Chloride) (CPVC) Plastic Pipe (SDR-PR); 2013.
- V. ASTM F493 - Standard Specification for Solvent Cements for Chlorinated Poly (Vinyl Chloride) (CPVC) Plastic Pipe and Fittings; 2014.
- W. AWS D1.1/D1.1M - Structural Welding Code - Steel; 2015.
- X. AWWA C105/A21.5 - Polyethylene Encasement for Ductile-Iron Pipe Systems; 2010.

- Y. AWWA C110/A21.10 - Ductile-Iron and Gray-Iron Fittings; 2012.
- Z. AWWA C111/A21.11 - Rubber-Gasket Joints for Ductile-Iron Pressure Pipe and Fittings; 2012.
- AA. AWWA C151/A21.51 - Ductile-Iron Pipe, Centrifugally Cast; 2009.
- AB. AWWA C606 - Grooved and Shouldered Joints; 2011.
- AC. FM (AG) - FM Approval Guide; current edition.
- AD. ITS (DIR) - Directory of Listed Products; current edition.
- AE. NFPA 13 - Standard for the Installation of Sprinkler Systems; 2016.
- AF. UL (DIR) - Online Certifications Directory; current listings at database.ul.com.
- AG. UL 262 - Gate Valves for Fire-Protection Service; Underwriters Laboratories Inc.; Current Edition, Including All Revisions.
- AH. UL 312 - Check Valves for Fire-Protection Service; Underwriters Laboratories Inc.; Current Edition, Including All Revisions.

1.4 SUBMITTALS

- A. See Division 1 Section - Administrative Requirements, for submittal procedures.
- B. Product Data: Provide manufacturer's catalog information. Indicate valve data and ratings.
- C. Shop Drawings: Indicate pipe materials used, jointing methods, supports, and floor and wall penetration seals. Indicate installation, layout, weights, mounting and support details, and piping connections.
- D. Project Record Documents: Record actual locations of components and tag numbering.
- E. Operation and Maintenance Data: Include installation instructions and spare parts lists.

1.5 QUALITY ASSURANCE

- A. Manufacturer Qualifications: Company specializing in manufacturing the Products specified in this section with minimum three years documented experience.
- B. Valves: Bear FM (AG), UL (DIR), ITS (DIR) or Warnock Hersey, and _____ product listing label or marking. Provide manufacturer's name and pressure rating marked on valve body.
- C. Products Requiring Electrical Connection: Listed and classified as suitable for the purpose specified and indicated.

1.6 DELIVERY, STORAGE, AND HANDLING

- A. Deliver and store valves in shipping containers, with labeling in place.
- B. Provide temporary protective coating on cast iron and steel valves.
- C. Provide temporary end caps and closures on piping and fittings. Maintain in place until installation.

PART 2 PRODUCTS

2.1 FIRE PROTECTION SYSTEMS

- A. Sprinkler Systems: Comply with NFPA 13.
- B. Welding Materials and Procedures: Comply with ASME BPVC-IX.

2.2 BURIED PIPING

- A. Steel Pipe: ASTM A53/A53M Schedule 40, ASTM A135/A135M Schedule 10, ASTM A795/A795M Standard Weight, or ASME B36.10M Schedule 40, black, with AWWA C105/A21.5 polyethylene jacket, or double layer, half-lapped polyethylene tape.
 - 1. Steel Fittings: ASME B16.9, wrought steel, butt welded, ASME B16.25, butt weld ends, ASTM A234/A234M, wrought carbon steel or alloy steel, ASME B16.5, steel flanges and fittings, or ASME B16.11, forged steel socket welded and threaded; with double layer, half-lapped polyethylene tape.
 - 2. Cast Iron Fittings: ASME B16.1, flanges and flanged fittings.
 - 3. Joints: Welded in accordance with AWS D1.1/D1.1M.

- B. Ductile Iron Pipe: AWWA C151/A21.51.
 - 1. Fittings: AWWA C110/A21.10, standard thickness.
 - 2. Joints: AWWA C111/A21.11, styrene-butadiene rubber (SBR) or vulcanized SBR gasket.
 - 3. Mechanical Couplings: Shaped composition sealing gasket, steel bolts, nuts, and washers.

2.3 ABOVE GROUND PIPING

- A. Steel Pipe: ASTM A795 Schedule 10 or ASTM A53 Schedule 40, black.
 - 1. Steel Fittings: ASME B16.9, wrought steel, buttwelded, ASME B16.25, buttweld ends, ASTM A234/A234M, wrought carbon steel or alloy steel, ASME B16.5, steel flanges and fittings, or ASME B16.11, forged steel socket welded and threaded.
 - 2. Cast Iron Fittings: ASME B16.1, flanges and flanged fittings and ASME B16.4, threaded fittings.
 - 3. Malleable Iron Fittings: ASME B16.3, threaded fittings and ASTM A47/A47M.
 - 4. Mechanical Grooved Couplings: Malleable iron housing clamps to engage and lock, "C" shaped elastomeric sealing gasket, steel bolts, nuts, and washers; galvanized for galvanized pipe.
 - 5. Mechanical Formed Fittings: Carbon steel housing with integral pipe stop and O-ring pocked and O-ring, uniformly compressed into permanent mechanical engagement onto pipe.
- B. CPVC Pipe: ASTM F442/F442M, SDR 13.5.
 - 1. Fittings: ASTM F438 Schedule 40, or ASTM F439 schedule 80, CPVC.
 - 2. Joints: Solvent welded, using ASTM F493 cement.

2.4 PIPE SLEEVES

- A. Vertical Piping:
 - 1. Sleeve Length: 1 inch above finished floor.
 - 2. Provide sealant for watertight joint.
- B. Pipe Passing Through Below Grade Exterior Walls:
 - 1. Zinc-coated or cast-iron pipe.
 - 2. Provide watertight space with link rubber or modular seal between sleeve and pipe on both pipe ends.
- C. Not required for wall hydrants for fire department connections or in drywall construction.
- D. Clearances:
 - 1. Wall, Floor, Floor, Partitions, and Beam Flanges: 1 inch greater than external; pipe diameter.
 - 2. All Rated Openings: Caulked tight with fire stopping material conforming to ASTM E814 in accordance with Firestopping section to prevent the spread of fire, smoke, and gases.

2.5 MANUFACTURED SLEEVE-SEAL SYSTEMS

- A. Modular/Mechanical Seal:
 - 1. Synthetic rubber interlocking links continuously fill annular space between pipe and wall/casing opening.
 - 2. Provide watertight seal between pipe and wall/casing opening.
 - 3. Elastomer element size and material in accordance with manufacturer's recommendations.
 - 4. Glass-reinforced plastic pressure endplates.

2.6 ESCUTCHEONS

- A. Material:
 - 1. Metals and Finish: Comply with ASME A112.18.1.
- B. Construction:
 - 1. One-piece for mounting on chrome-plated tubing or pipe and one-piece or split-pattern type elsewhere.
 - 2. Internal spring tension devices or setscrews to maintain a fixed position against a surface.

2.7 PIPE HANGERS AND SUPPORTS

- A. Hangers for Pipe Sizes 1/2 to 1-1/2 inch: Malleable iron, adjustable swivel, split ring.
- B. Hangers for Pipe Sizes 2 inches and Over: Carbon steel, adjustable, clevis.

- C. Multiple or Trapeze Hangers: Steel channels with welded spacers and hanger rods.
- D. Wall Support for Pipe Sizes to 3 inches: Cast iron hook.
- E. Wall Support for Pipe Sizes 4 inches and Over: Welded steel bracket and wrought steel clamp.
- F. Vertical Support: Steel riser clamp.
- G. Floor Support: Cast iron adjustable pipe saddle, lock nut, nipple, floor flange, and concrete pier or steel support.

2.8 MECHANICAL COUPLINGS

- A. Rigid Mechanical Couplings for Grooved Joints:
 - 1. Dimensions and Testing: Comply with AWWA C606.
 - 2. Minimum Working Pressure: 300 psig.
 - 3. Housing Material: Fabricate of ductile iron complying with ASTM A536.
 - 4. Housing Coating: Factory applied orange enamel.
 - 5. Gasket Material: EPDM suitable for operating temperature range from minus 30 degrees F to 230 degrees F.
 - 6. Bolts and Nuts: Hot-dipped-galvanized or zinc-electroplated steel.

2.9 GATE VALVES

- A. Up to and including 2 inches:
 - 1. Bronze body, bronze trim, rising stem, handwheel, solid wedge or disc, threaded ends.
- B. Over 2 inches:
 - 1. Iron body, bronze trim, rising stem pre-grooved for mounting tamper switch, handwheel, OS&Y, solid rubber covered bronze or cast iron wedge, flanged ends.
- C. Over 4 inches:
 - 1. Iron body, bronze trim, non-rising stem with bolted bonnet, solid bronze wedge, flanged ends, iron body indicator post assembly.

2.10 GLOBE OR ANGLE VALVES

- A. Up to and including 2 inches:
 - 1. Bronze body, bronze trim, rising stem and handwheel, inside screw, renewable rubber disc, threaded ends, with backseating capacity repackable under pressure.
- B. Over 2 inches:
 - 1. Iron body, bronze trim, rising stem, handwheel, OS&Y, plug-type disc, flanged ends, renewable seat and disc.

2.11 BUTTERFLY VALVES

- A. Bronze Body:
 - 1. Stainless steel disc, resilient replaceable seat, threaded or grooved ends, extended neck, handwheel and gear drive and integral indicating device, and built-in tamper proof switch rated 10 amp at 115 volt AC.
- B. Cast or Ductile Iron Body
 - 1. Cast or ductile iron, chrome or nickel plated ductile iron or aluminum bronze disc, resilient replaceable EPDM seat, wafer, lug, or grooved ends, extended neck, handwheel and gear drive and integral indicating device, and internal tamper switch rated 10 amp at 115 volt AC.

2.12 CHECK VALVES

- A. Up to and including 2 inches:
 - 1. Bronze body and swing disc, rubber seat, threaded ends.
- B. Over 2 inches:
 - 1. Iron body, bronze trim, swing check with rubber disc, renewable disc and seat, flanged ends with automatic ball check.
- C. 4 inches and Over:

1. Iron body, bronze disc, stainless steel spring, resilient seal, threaded, wafer, or flanged ends.

2.13 DRAIN VALVES

- A. Compression Stop:
 1. Bronze with hose thread nipple and cap.
- B. Ball Valve:
 1. Brass with cap and chain, 3/4 inch hose thread.

PART 3 EXECUTION

3.1 PREPARATION

- A. Ream pipe and tube ends. Remove burrs.
- B. Remove scale and foreign material, from inside and outside, before assembly.
- C. Prepare piping connections to equipment with flanges or unions.

3.2 INSTALLATION

- A. Install sprinkler system and service main piping, hangers, and supports in accordance with NFPA 13.
- B. The entire building shall be provided with a fire protection sprinkler system.
- C. Prepare design documents including shop drawings and hydraulic calculations in accordance with NFPA 13 and submit to Authority Having Jurisdiction for approval prior to installation. Design shall be performed by a licensed Professional Engineer.
- D. Install piping, hangers, and supports in accordance with NFPA 14.
- E. Route piping in orderly manner, plumb and parallel to building structure. Maintain gradient.
- F. Install piping to conserve building space, to not interfere with use of space and other work.
- G. Piping shall be concealed where routed in finished spaces.
- H. Group piping whenever practical at common elevations.
- I. Sleeve pipes passing through partitions, walls, and floors.
- J. Install piping to allow for expansion and contraction without stressing pipe, joints, or connected equipment.
- K. Inserts:
 1. Provide inserts for placement in concrete formwork.
 2. Provide inserts for suspending hangers from reinforced concrete slabs and sides of reinforced concrete beams.
 3. Provide hooked rod to concrete reinforcement section for inserts carrying pipe over 4 inches.
 4. Where concrete slabs form finished ceiling, locate inserts flush with slab surface.
- L. Pipe Hangers and Supports:
 1. Install hangers to provide minimum 1/2 inch space between finished covering and adjacent work.
 2. Place hangers within 12 inches of each horizontal elbow.
 3. Use hangers with 1-1/2 inch minimum vertical adjustment. Design hangers for pipe movement without disengagement of supported pipe.
 4. Support vertical piping at every other floor. Support riser piping independently of connected horizontal piping.
 5. Where several pipes can be installed in parallel and at same elevation, provide multiple or trapeze hangers.
 6. Support piping from top chord of bar joists. Support from deck or bottom chord is not acceptable.
- M. Slope piping and arrange systems to drain at low points. Use eccentric reducers to maintain top of pipe level.
- N. Prepare pipe, fittings, supports, and accessories for finish painting. Where pipe support members are welded to structural building framing, scrape, brush clean, and apply one coat of zinc rich primer to welding.

- O. Do not penetrate building structural members unless indicated.
- P. Provide sleeves when penetrating footings, floors, walls, and partitions. Seal pipe including sleeve penetrations to achieve fire resistance equivalent to fire separation required.
 - 1. Underground Piping: Caulk pipe sleeve watertight with lead and oakum or mechanically expandable chloroprene inserts with bitumen sealed metal components.
 - 2. Aboveground Piping:
 - a. Pack solid using mineral fiber complying with ASTM C592.
 - b. Fill space with an elastomer caulk to a depth of 0.50 inch where penetrations occur between conditioned and unconditioned spaces.
 - 3. All Rated Openings: Caulk tight with fire stopping material conforming to ASTM E814 in accordance with Firestopping section to prevent the spread of fire, smoke, and gases.
 - 4. Caulk exterior wall sleeves watertight with lead and oakum or mechanically expandable chloroprene inserts with mastic-sealed components.
- Q. Manufactured Sleeve-Seal Systems:
 - 1. Install manufactured sleeve-seal systems in sleeves located in grade slabs and exterior concrete walls at piping entrances into building.
 - 2. Provide sealing elements of the size, quantity, and type required for the piping and sleeve inner diameter or penetration diameter.
 - 3. Locate piping in center of sleeve or penetration.
 - 4. Install field assembled sleeve-seal system components in annular space between sleeve and piping.
 - 5. Tighten bolting for a watertight seal.
 - 6. Install in accordance with manufacturer's recommendations.
- R. Escutcheons:
 - 1. Install and firmly attach escutcheons at piping penetrations into finished spaces.
 - 2. Provide escutcheons on both sides of partitions separating finished areas through which piping passes.
 - 3. Use chrome plated escutcheons in occupied spaces and to conceal openings in construction.
- S. When installing more than one piping system material, ensure system components are compatible and joined to ensure the integrity of the system. Provide necessary joining fittings. Ensure flanges, unions, and couplings for servicing are consistently provided.
- T. Install valves with stems upright or horizontal, not inverted. Remove protective coatings prior to installation.
- U. Provide gate valves for shut-off or isolating service.
- V. Provide drain valves at main shut-off valves, low points of piping and apparatus.

END OF SECTION 210500

SECTION 210523

GENERAL-DUTY VALVES FOR WATER-BASED FIRE-SUPPRESSION PIPING

PART 1 GENERAL

1.1 SECTION INCLUDES

- A. Two-piece ball valves with indicators.
- B. Bronze butterfly valves with indicators.
- C. Iron butterfly valves with indicators.
- D. Check valves.
- E. Bronze OS&Y gate valves.
- F. Iron OS&Y gate valves.
- G. NRS gate valves.
- H. Indicator posts.
- I. Trim and drain valves.

1.2 RELATED REQUIREMENTS

- A. Section 210500 - Common Work Results for Fire Suppression: Pipe and fittings.
- B. Section 210553 - Identification for Fire Suppression Piping and Equipment.
- C. Section 211200 - Fire-Suppression Standpipes.
- D. Section 211300 - Fire-Suppression Sprinkler Systems.
- E. Section 284600 - Fire Detection and Alarm.

1.3 ABBREVIATIONS AND ACRONYMS

- A. EPDM: Ethylene-propylene diene monomer.
- B. NBR: Acrylonitrile-butadiene, Buna-N, or nitrile rubber.
- C. NRS: Non-rising stem.
- D. OS&Y: Outside screw and yoke.
- E. PTFE: Polytetrafluoroethylene.
- F. SBR: Styrene-butadiene rubber.

1.4 REFERENCE STANDARDS

- A. ASME BPVC-IX - Boiler and Pressure Vessel Code, Section IX - Welding, Brazing, and Fusing Qualifications; 2015.
- B. FM (AG) - FM Approval Guide; current edition.
- C. NFPA 13 - Standard for the Installation of Sprinkler Systems; 2016.
- D. UL (DIR) - Online Certifications Directory; current listings at database.ul.com.

1.5 SUBMITTALS

- A. Product Data: Provide data on valves including manufacturers catalog information. Submit performance ratings, rough-in details, weights, support requirements, and piping connections.
- B. Warranty: Submit manufacturer warranty and ensure that forms have been completed in Owner's name and registered with manufacturer.
- C. Operation and Maintenance Data: Include manufacturer's descriptive literature, operating instructions, maintenance and repair data, and parts listings.

1.6 QUALITY ASSURANCE

- A. Manufacturer Qualifications:
 - 1. Obtain valves for each valve type from single manufacturer.

2. Company must specialize in manufacturing products specified in this section, with not less than three years of documented experience.
- B. Where listed products are specified, provide products listed, classified, and labeled by FM (AG), UL (DIR), or testing firm acceptable to authorities having jurisdiction as suitable for the purpose indicated.
- C. Welding Materials and Procedures: Comply with ASME BPVC-IX.
- D. Installer and Maintenance Contractor Qualifications:
 1. Company specializing in performing the work of this section with minimum five years documented experience.
 2. Trained and approved by manufacturer to design, install, test and maintain the equipment specified herein.
 3. Complies with manufacturer's certification requirements.
 4. Complies with manufacturer's insurance requirements.

1.7 DELIVERY, STORAGE, AND HANDLING

- A. Prepare valves for shipping as follows:
 1. Protect internal parts against rust and corrosion.
 2. Set valves open to minimize exposure of functional surfaces.
- B. Use the following precautions during storage:
 1. Maintain valve end protection and protect flanges and specialties from dirt.
 - a. Provide temporary inlet and outlet caps.
 - b. Maintain caps in place until installation.
 2. Store valves in shipping containers and maintain in place until installation.
 - a. Store valves indoors and maintain at higher than ambient dew point temperature.
 - b. If outdoor storage is unavoidable, store valves off the ground in watertight enclosures.
- C. Use the following precautions for handling:
 1. Do not use operating handles or stems as lifting or rigging points.

PART 2 PRODUCTS

2.1 GENERAL REQUIREMENTS

- A. Comply with NFPA 13 for valves.
- B. Valve Pressure Ratings: Not less than minimum pressure rating indicated or higher as required.
- C. Valve Sizes: Same as upstream piping unless otherwise indicated.
- D. Valve Actuator Types:
 1. Worm-gear actuator with handwheel for quarter-turn valves, except trim and drain valves.
 2. Handwheel: For other than quarter-turn trim and drain valves.
 3. Hand-lever: For quarter-turn trim and drain valves 2 NPS and smaller.

2.2 TWO-PIECE BALL VALVES WITH INDICATORS

- A. Description:
 1. Minimum Pressure Rating: 175 psig.
 2. Body Design: Two piece.
 3. Body Material: Forged brass or bronze.
 4. Port Size: Full or standard.
 5. Seat: PTFE.
 6. Stem: Bronze or stainless steel.
 7. Ball: Chrome-plated brass.
 8. Actuator: Worm gear or traveling nut.
 9. Supervisory Switch: Internal or external.

2.3 BRONZE BUTTERFLY VALVES WITH INDICATORS

- A. Minimum Pressure Rating: 175 psig.
- B. Body Material: Bronze.

- C. Seat: EPDM.
 - D. Stem: Bronze or stainless steel.
 - E. Disc: Bronze with EPDM coating.
 - F. Actuator: Worm gear or traveling nut.
 - G. Supervisory Switch: Internal or external.
- 2.4 IRON BUTTERFLY VALVES WITH INDICATORS
- A. Minimum Pressure Rating: 175 psig.
 - B. Body Material: Cast or ductile iron with nylon, EPDM, epoxy, or polyamide coating.
 - C. Seat: EPDM.
 - D. Stem: Stainless steel.
 - E. Disc: Ductile iron, nickel plated.
 - F. Actuator: Worm gear or traveling nut.
 - G. Supervisory Switch: Internal or external.
 - H. Body Design: Grooved-end connections.
- 2.5 CHECK VALVES
- A. Minimum Pressure Rating: 175 psig.
 - B. Type: Center guided check valve.
 - C. Body Material: Cast iron, ductile iron.
 - D. Center guided check with elastomeric seal.
 - E. Hinge Spring: Stainless steel.
 - F. End Connections: Flanged, grooved, or threaded.
- 2.6 BRONZE OS&Y GATE VALVES
- A. Minimum Pressure Rating: 175 psig.
 - B. Body and Bonnet Material: Bronze or brass.
 - C. Wedge: One-piece bronze or brass.
 - D. Wedge Seat: Bronze.
 - E. Stem: Bronze or brass.
 - F. Packing: Non-asbestos PTFE.
 - G. Supervisory Switch: External.
 - H. End Connections: Threaded.
- 2.7 IRON OS&Y GATE VALVES
- A. Minimum Pressure Rating: 175 psig.
 - B. Body and Bonnet Material: Cast or ductile iron.
 - C. Wedge: Cast or ductile iron, or bronze with elastomeric coating.
 - D. Wedge Seat: Cast or ductile iron, or bronze with elastomeric coating.
 - E. Stem: Brass or bronze.
 - F. Packing: Non-asbestos PTFE.
 - G. Supervisory Switch: External.
 - H. End Connections: Flanged.
- 2.8 NRS GATE VALVES
- A. Minimum Pressure Rating: 175 psig.

- B. Body and Bonnet Material: Cast or ductile iron.
- C. Wedge: Cast or ductile iron with elastomeric coating.
- D. Stem: Brass or bronze.
- E. Packing: Non-asbestos PTFE.
- F. Supervisory Switch: External.
- G. End Connections: Flanged.

2.9 INDICATOR POSTS

- A. Type: Underground.
- B. Base Barrel Material: Cast or ductile iron.
- C. Cap: Cast or ductile iron.
- D. Operation: Wrench.

2.10 TRIM AND DRAIN VALVES

- A. Ball Valves:
 - 1. Description:
 - a. Pressure Rating: 175 psig.
 - b. Body Design: Two piece.
 - c. Body Material: Forged brass or bronze.
 - d. Port Size: Full or standard.
 - e. Seat: PTFE.
 - f. Stem: Bronze or stainless steel.
 - g. Ball: Chrome-plated brass.
 - h. Actuator: Hand-lever.
- B. Angle Valves:
 - 1. Description:
 - a. Pressure Rating: 175 psig.
 - b. Body Material: Brass or bronze.
 - c. Ends: Threaded.
 - d. Stem: Bronze.
 - e. Disc: Bronze.
 - f. Packing: Asbestos free.
 - g. Handwheel: Malleable iron, bronze, or aluminum.
- C. Globe Valves:
 - 1. Description:
 - a. Pressure Rating: 175 psig.
 - b. Body Material: Bronze with integral seat and screw-in bonnet.
 - c. Ends: Threaded.
 - d. Stem: Bronze.
 - e. Disc Holder and Nut: Bronze.
 - f. Disc Seat: Nitrile.
 - g. Packing: Asbestos free.
 - h. Handwheel: Malleable iron, bronze, or aluminum.

PART 3 EXECUTION

3.1 EXAMINATION

- A. Confirm valve interior to be free of foreign matter and corrosion.
- B. Remove packing materials.
- C. Examine guides and seats by operating valves from the fully open position to the fully closed position.
- D. Examine valve threads and mating pipe for form and cleanliness.

3.2 INSTALLATION

- A. Comply with specific valve installation requirements and application in the following Sections:
- B. Install listed fire protection shutoff valves supervised-open, located to control sources of water supply except from fire department connections.
 - 1. Install permanent identification signs indicating portion of system controlled by each valve.
- C. Install check valve in water supply connections and backflow preventer at potable water supply connections.
- D. Valves in horizontal piping installed with stem at or above the pipe center.
- E. Position valves to allow full stem movement.
- F. Install valve tags. Comply with Section 210553 requirements for valve tags, schedules, and signs on surfaces concealing valves; and the appropriate NFPA standard applying to the piping system in which valves are installed.

END OF SECTION 210523

SECTION 210553

IDENTIFICATION FOR FIRE SUPPRESSION PIPING AND EQUIPMENT

PART 1 GENERAL

1.1 SECTION INCLUDES

- A. Nameplates.
- B. Tags.
- C. Stencils.
- D. Pipe markers.
- E. Ceiling tacks.

1.2 REFERENCE STANDARDS

1.3 SUBMITTALS

- A. List: Submit list of wording, symbols, letter size, and color coding for mechanical identification.
- B. Chart and Schedule: Submit valve chart and schedule, including valve tag number, location, function, and valve manufacturer's name and model number.
- C. Product Data: Provide manufacturers catalog literature for each product required.
- D. Manufacturer's Installation Instructions: Indicate special procedures, and installation instructions.

PART 2 PRODUCTS

2.1 NAMEPLATES

- A. Description: Laminated three-layer plastic with engraved letters.

2.2 TAGS

- A. Plastic Tags: Laminated three-layer plastic with engraved black letters on light contrasting background color. Tag size minimum 1-1/2 inch diameter.
- B. Metal Tags: Brass with stamped letters; tag size minimum 1-1/2 inch diameter with smooth edges.
- C. Valve Tag Chart: Typewritten letter size list in anodized aluminum frame.

2.3 STENCILS

- A. Stencils: With clean cut symbols and letters of following size:
 - 1. 3/4 to 1-1/4 inch Outside Diameter of Insulation or Pipe: 8 inch long color field, 1/2 inch high letters.
 - 2. 1-1/2 to 2 inch Outside Diameter of Insulation or Pipe: 8 inch long color field, 3/4 inch high letters.
 - 3. 2-1/2 to 6 inch Outside Diameter of Insulation or Pipe: 12 inch long color field, 1-1/4 inch high letters.
 - 4. Equipment: 2-1/2 inch high letters.

2.4 PIPE MARKERS

- A. Plastic Pipe Markers: Factory fabricated, flexible, semi-rigid plastic, preformed to fit around pipe or pipe covering; minimum information indicating flow direction arrow and identification of fluid being conveyed.
- B. Plastic Tape Pipe Markers: Flexible, vinyl film tape with pressure sensitive adhesive backing and printed markings.
- C. Underground Plastic Pipe Markers: Bright colored continuously printed plastic ribbon tape, minimum 6 inches wide by 4 mil thick, manufactured for direct burial service.

2.5 CEILING TACKS

- A. Description: Steel with 3/4 inch diameter color coded head.

PART 3 EXECUTION

3.1 PREPARATION

- A. Degrease and clean surfaces to receive adhesive for identification materials.

3.2 INSTALLATION

- A. Install nameplates with corrosive-resistant mechanical fasteners, or adhesive. Apply with sufficient adhesive to ensure permanent adhesion and seal with clear lacquer.
- B. Install tags with corrosion resistant chain.
- C. Install plastic pipe markers in accordance with manufacturer's instructions.
- D. Install plastic tape pipe markers complete around pipe in accordance with manufacturer's instructions.
- E. Install underground plastic pipe markers 6 to 8 inches below finished grade, directly above buried pipe.
- F. Use tags on piping 3/4 inch diameter and smaller.
- G. Locate ceiling tacks to locate valves above T-bar type panel ceilings. Locate in corner of panel closest to equipment.

END OF SECTION 210553

SECTION 211300
FIRE-SUPPRESSION SPRINKLER SYSTEMS

PART 1 GENERAL

1.1 SECTION INCLUDES

- A. Wet-pipe sprinkler system.
- B. Dry-pipe sprinkler system.
- C. System design, installation, and certification.
- D. Fire department connections.

1.2 RELATED REQUIREMENTS

- A. Section 210500 - Common Work Results for Fire Suppression: Pipe and fittings.
- B. Section 220553 - Identification for Plumbing Piping and Equipment.

1.3 REFERENCE STANDARDS

- A. FM (AG) - FM Approval Guide; current edition.
- B. FM P7825 - Approval Guide; Factory Mutual Research Corporation; current edition.
- C. ICC-ES AC01 - Acceptance Criteria for Expansion Anchors in Masonry Elements; 2012.
- D. ICC-ES AC106 - Acceptance Criteria for Predrilled Fasteners (Screw Anchors) in Masonry Elements; 2012.
- E. ICC-ES AC193 - Acceptance Criteria for Mechanical Anchors in Concrete Elements; 2013.
- F. ICC-ES AC308 - Acceptance Criteria for Post-Installed Adhesive Anchors in Concrete Elements; 2013.
- G. NFPA 13 - Standard for the Installation of Sprinkler Systems; 2016.
- H. UL (DIR) - Online Certifications Directory; current listings at database.ul.com.

1.4 SUBMITTALS

- A. See Division 1 Section - Administrative Requirements, for submittal procedures.
- B. Product Data: Provide data on sprinklers, valves, and specialties, including manufacturers catalog information. Submit performance ratings, rough-in details, weights, support requirements, and piping connections.
- C. Shop Drawings:
 - 1. Submit preliminary layout of finished ceiling areas indicating only sprinkler locations coordinated with ceiling installation. Additionally, indicate general routing of piping for review by Architect.
 - 2. Indicate hydraulic calculations, detailed pipe layout, hangers and supports, sprinklers, components, and accessories. Indicate system controls.
 - 3. Submit shop drawings, product data, and hydraulic calculations to authority having jurisdiction for approval. Drawings and calculations shall be stamped by a licenced professional engineer.
 - 4. Installation shall be fully coordinated with structure and all other trades. Coordination shall be performed with installed conditions, not just the construction drawings. Rework of sprinkler piping due to conflicts with field conditions shall be performed without cost to the Owner or Engineer.
- D. Project Record Documents: Record actual locations of sprinklers and deviations of piping from drawings. Indicate drain and test locations.
- E. Operation and Maintenance Data: Include components of system, servicing requirements, record drawings, inspection data, replacement part numbers and availability, and location and numbers of service depot.
- F. Maintenance Materials: Furnish the following for Owner's use in maintenance of project.
 - 1. See Section 016000 - Product Requirements, for additional provisions.
 - 2. Extra Sprinklers: Type and size matching those installed in quantity required by referenced NFPA design and installation standard.
 - 3. Sprinkler Wrenches: For each sprinkler type.

1.5 QUALITY ASSURANCE

- A. Maintain one copy of referenced design and installation standard on site.
- B. Comply with FM (AG) requirements.
- C. Designer Qualifications: Design system under direct supervision of a Professional Engineer experienced in design of this type of work and licensed in Texas.
- D. Equipment and Components: Provide products that bear FM (AG) label or marking.
- E. Products Requiring Electrical Connection: Listed and classified by UL (DIR) as suitable for the purpose specified and indicated.

1.6 DELIVERY, STORAGE, AND HANDLING

- A. Store products in shipping containers and maintain in place until installation. Provide temporary inlet and outlet caps. Maintain caps in place until installation.

1.7 EXTRA MATERIALS

- A. Provide extra sprinklers of type and size matching those installed, in quantity required by referenced NFPA design and installation standard.
- B. Provide suitable wrenches for each sprinkler type.
- C. Provide metal storage cabinet located adjacent to alarm valve.

PART 2 PRODUCTS

2.1 SPRINKLER SYSTEM

- A. Sprinkler System: Provide coverage for entire building.
- B. Occupancy: Light hazard; comply with NFPA 13.
- C. Water Supply: Determine volume and pressure from water flow test data.
- D. Interface system with building fire and smoke alarm system.
- E. Provide fire department connections at locations coordinated with Fire Department.
- F. Storage Cabinet for Spare Sprinklers and Tools: Steel, located adjacent to alarm valve.
- G. Pipe Hanger Fasteners: Attach hangers to structure using appropriate fasteners, as follows:
 - 1. Concrete Wedge Expansion Anchors: Complying with ICC-ES AC193.
 - 2. Masonry Wedge Expansion Anchors: Complying with ICC-ES AC01.
 - 3. Concrete Screw Type Anchors: Complying with ICC-ES AC193.
 - 4. Masonry Screw Type Anchors: Complying with ICC-ES AC106.
 - 5. Concrete Adhesive Type Anchors: Complying with ICC-ES AC308.
 - 6. Other Types: As required.

2.2 SPRINKLERS

- A. Suspended Ceiling Type: Recessed or concealed pendant type with matching push on escutcheon or cover plate.
 - 1. Finish: Enamel, color white.
 - 2. Escutcheon Plate Finish: Enamel, color white.
 - 3. Cover Plate Finish: White enamel.
 - 4. Fusible Link: Fusible solder link type temperature rated for specific area hazard.
- B. Exposed Area Type: Standard upright type with guard.
 - 1. Finish: Brass.
 - 2. Fusible Link: Fusible solder link type temperature rated for specific area hazard.
- C. Sidewall Type: Recessed horizontal sidewall type with matching push on escutcheon plate .
 - 1. Finish: Enamel, color white.
 - 2. Escutcheon Plate Finish: Enamel, color white.
 - 3. Fusible Link: Fusible solder link type temperature rated for specific area hazard.

- D. Guards: Finish to match sprinkler finish.
 - 1. Provide guards at all heads in back of house areas including linen and storage rooms.
 - 2. Provide guards at all heads installed below 8' AFF.

2.3 PIPING SPECIALTIES

- A. Dry Pipe Sprinkler Alarm Valve: Check type valve with divided seat ring, rubber faced clapper to automatically actuate water motor alarm, accelerator, and with the following additional capabilities and features:
 - 1. Activate electric alarm.
 - 2. Test and drain valve.
 - 3. Externally resettable.
 - 4. Replaceable internal components without removing valve from installed position.
- B. Wet Pipe Sprinkler Alarm Valve: Check type valve with divided seat ring, rubber faced clapper to automatically actuate water motor alarm and electric alarm, with pressure retard chamber and variable pressure trim; with test and drain valve.
- C. Backflow Preventer: Double check valve assembly backflow preventer with drain and OS & Y gate valve on each end. Coordinate requirements with Authority Having Jurisdiction.
- D. Test Connections:
 - 1. Backflow Preventer Test Connection:
 - a. Provide downstream of the backflow prevention assembly, listed hose valves with 2.5 inch National Standard male hose threads with cap and chain.
- E. Electric Alarm: Electrically operated chrome plated gong with pressure alarm switch.
- F. Water Flow Switch: Vane type switch for mounting horizontal or vertical, with two contacts; rated 10 amp at 125 volt AC and 2.5 amp at 24 volt DC.
- G. Fire Department Connections:
 - 1. Type: Flush mounted wall type with chrome plated finish.
 - 2. Outlets: Two way with thread size to suit fire department hardware; threaded dust cap and chain of matching material and finish.
 - 3. Drain: 3/4 inch automatic drip, outside.
 - 4. Label: "Auto. Sprinkler".

2.4 AIR COMPRESSOR

- A. Compressor: Single-unit, electric motor driven, motor, motor starter, safety valves, check valves, air maintenance device incorporating electric pressure switch and unloader valve.
- B. Electrical Characteristics:
 - 1. 1/3 hp.
 - 2. 125 volts, single phase, 60 Hz.

PART 3 EXECUTION

3.1 INSTALLATION

- A. Install in accordance with referenced NFPA design and installation standard.
- B. Install equipment in accordance with manufacturer's instructions.
- C. Install buried shut-off valves in valve box. Provide post indicator.
- D. Provide approved backflow preventer assembly at sprinkler system water source connection.
- E. Locate fire department connection with sufficient clearance from walls, obstructions, or adjacent siamese connectors to allow full swing of fire department wrench handle. Coordinate with Authority Having Jurisdiction.
- F. Place pipe runs to minimize obstruction to other work.
- G. Place piping in concealed spaces above finished ceilings.
- H. Center sprinklers in two directions in ceiling tile and provide piping offsets as required.

- I. Apply masking tape or paper cover to ensure concealed sprinklers, cover plates, and sprinkler escutcheons do not receive field paint finish. Remove after painting. Replace painted sprinklers.
 - J. Flush entire piping system of foreign matter.
 - K. Hydrostatically test entire system.
 - L. Required tests must be witnessed by authority having jurisdiction.
 - M. Public areas must have concealed or recessed heads. Concealed or recessed ceiling or sidewall heads may be used in apartments.
 - N. Areas subject to freezing shall be provided with dry type heads.
- 3.2 INTERFACE WITH OTHER PRODUCTS
- A. Ensure required devices are installed and connected as required to fire alarm system.

END OF SECTION 211300

SECTION 220553
IDENTIFICATION FOR PLUMBING PIPING AND EQUIPMENT

PART 1 GENERAL

1.1 SECTION INCLUDES

- A. Nameplates.
- B. Tags.
- C. Pipe markers.

1.2 REFERENCE STANDARDS

- A. ASME A13.1 - Scheme for the Identification of Piping Systems; 2007.
- B. ASME A13.1 - Scheme for the Identification of Piping Systems; The American Society of Mechanical Engineers; 2007.

1.3 SUBMITTALS

- A. See Division 1 Section - Administrative Requirements, for submittal procedures.
- B. List: Submit list of wording, symbols, letter size, and color coding for mechanical identification.
- C. Chart and Schedule: Submit valve chart and schedule, including valve tag number, location, function, and valve manufacturer's name and model number.
- D. Product Data: Provide manufacturers catalog literature for each product required.
- E. Project Record Documents: Record actual locations of tagged valves.

PART 2 PRODUCTS

2.1 NAMEPLATES

- A. Description: Laminated three-layer plastic with engraved letters.
 - 1. Letter Color: White.
 - 2. Letter Height: 1/4 inch.
 - 3. Background Color: Black.

2.2 TAGS

- A. Plastic Tags: Laminated three-layer plastic with engraved black letters on light contrasting background color. Tag size minimum 1-1/2 inch diameter.
- B. Metal Tags: Brass with stamped letters; tag size minimum 1-1/2 inch diameter with smooth edges.
- C. Chart: Typewritten letter size list in anodized aluminum frame.

2.3 PIPE MARKERS

- A. Comply with ASME A13.1.
- B. Plastic Tape Pipe Markers: Flexible, vinyl film tape with pressure sensitive adhesive backing and printed markings.

PART 3 EXECUTION

3.1 INSTALLATION

- A. Install plastic nameplates with corrosive-resistant mechanical fasteners, or adhesive. Apply with sufficient adhesive to ensure permanent adhesion and seal with clear lacquer.
- B. Install tags with corrosion resistant chain.
- C. Install plastic pipe markers in accordance with manufacturer's instructions.
- D. Install plastic tape pipe markers complete around pipe in accordance with manufacturer's instructions.
- E. Identify equipment with plastic nameplates. Small devices, such as in-line pumps, may be identified with tags.
- F. Identify control panels and major control components outside panels with plastic nameplates.

- G. Identify valves in main and branch piping with tags.
- H. Identify piping, concealed or exposed, with plastic pipe markers. Use tags on piping 3/4 inch diameter and smaller. Identify service, flow direction, and pressure. Install in clear view and align with axis of piping. Locate identification not to exceed 20 feet on straight runs including risers and drops, adjacent to each valve and Tee, at each side of penetration of structure or enclosure, and at each obstruction.

END OF SECTION 220553

SECTION 220719
PLUMBING PIPING INSULATION

PART 1 GENERAL

1.1 SECTION INCLUDES

- A. Piping insulation.
- B. Jackets and accessories.

1.2 REFERENCE STANDARDS

- A. ASTM C177 - Standard Test Method for Steady-State Heat Flux Measurements and Thermal Transmission Properties by Means of the Guarded-Hot-Plate Apparatus; 2013.
- B. ASTM C195 - Standard Specification for Mineral Fiber Thermal Insulating Cement; 2007 (Reapproved 2013).
- C. ASTM C449 - Standard Specification for Mineral Fiber Hydraulic-Setting Thermal Insulating and Finishing Cement; 2007 (Reapproved 2013).
- D. ASTM C534/C534M - Standard Specification for Preformed Flexible Elastomeric Cellular Thermal Insulation in Sheet and Tubular Form; 2014.
- E. ASTM C547 - Standard Specification for Mineral Fiber Pipe Insulation; 2015.
- F. ASTM C795 - Standard Specification for Thermal Insulation for Use in Contact with Austenitic Stainless Steel; 2008 (Reapproved 2013).
- G. ASTM E84 - Standard Test Method for Surface Burning Characteristics of Building Materials; 2015a.
- H. ASTM E96/E96M - Standard Test Methods for Water Vapor Transmission of Materials; 2014.
- I. UL 723 - Standard for Test for Surface Burning Characteristics of Building Materials; Current Edition, Including All Revisions.

1.3 SUBMITTALS

- A. Product Data: Provide product description, thermal characteristics, list of materials and thickness for each service
- B. Manufacturer's Instructions: Indicate installation procedures that ensure acceptable workmanship and installation standards will be achieved.

PART 2 PRODUCTS

2.1 REGULATORY REQUIREMENTS

- A. Surface Burning Characteristics: Flame spread index/Smoke developed index of 25/50, maximum, when tested in accordance with ASTM E84 or UL 723.

2.2 GLASS FIBER

- A. Manufacturers:
 - 1. Knauf Insulation: www.knaufusa.com.
 - 2. Johns Manville Corporation: www.jm.com.
 - 3. Owens Corning Corp: www.owenscorning.com.
 - 4. CertainTeed Corporation: www.certainteed.com.
- B. Insulation: ASTM C547 and ASTM C795; rigid molded, noncombustible.
 - 1. K Value: ASTM C177, 0.24 at 75 degrees F.
 - 2. Maximum Service Temperature: 850 degrees F.
 - 3. Maximum Moisture Absorption: 0.2 percent by volume.
- C. Insulation: ASTM C547 and ASTM C795; semi-rigid, noncombustible, end grain adhered to jacket.
 - 1. K Value: ASTM C177, 0.24 at 75 degrees F.
 - 2. Maximum Service Temperature: 650 degrees F.
 - 3. Maximum Moisture Absorption: 0.2 percent by volume.

- D. Vapor Barrier Jacket: White Kraft paper with glass fiber yarn, bonded to aluminized film; moisture vapor transmission when tested in accordance with ASTM E96/E96M of 0.02 perm-inches.
- E. Vapor Barrier Lap Adhesive: Compatible with insulation.
 - 1. Compatible with insulation.
- F. Insulating Cement/Mastic: ASTM C195; hydraulic setting on mineral wool.
 - 1. ASTM C195; hydraulic setting on mineral wool.
- G. Fibrous Glass Fabric:
 - 1. Cloth: Untreated; 9 oz/sq yd weight.
 - 2. Blanket: 1.0 lb/cu ft density.
 - 3. Weave: 5 by 5.
- H. Indoor Vapor Barrier Finish:
 - 1. Cloth: Untreated; 9 oz/sq yd weight.
 - 2. Vinyl emulsion type acrylic, compatible with insulation, black color.
- I. Insulating Cement: ASTM C449.
 - 1. ASTM C449/C449M.

2.3 FLEXIBLE ELASTOMERIC CELLULAR INSULATION

- A. Manufacturers:
 - 1. Armacell LLC; AP Armaflex: www.armacell.us/#sle.
 - 2. K-Flex USA: www.kflexusa.com.
- B. Insulation: Preformed flexible elastomeric cellular rubber insulation complying with ASTM C534/C534M Grade 1; use molded tubular material wherever possible.
 - 1. Minimum Service Temperature: Minus 40 degrees F.
 - 2. Maximum Service Temperature: 220 degrees F.
 - 3. Connection: Waterproof vapor barrier adhesive.
- C. Elastomeric Foam Adhesive: Air dried, contact adhesive, compatible with insulation.

2.4 JACKETS

- A. PVC Plastic.
 - 1. Jacket: One piece molded type fitting covers and sheet material, off-white color.
 - a. Minimum Service Temperature: 0 degrees F.
 - b. Maximum Service Temperature: 150 degrees F.
 - c. Moisture Vapor Permeability: 0.002 perm inch, maximum, when tested in accordance with ASTM E96/E96M.
 - d. Thickness: 10 mil.
 - e. Connections: Brush on welding adhesive.

PART 3 EXECUTION

3.1 EXAMINATION

- A. Verify that piping has been tested before applying insulation materials.
- B. Verify that surfaces are clean and dry, with foreign material removed.

3.2 INSTALLATION

- A. Install in accordance with manufacturer's instructions.
- B. Exposed Piping: Locate insulation and cover seams in least visible locations.
- C. Insulated pipes conveying fluids below ambient temperature: Insulate entire system including fittings, valves, unions, flanges, strainers, flexible connections, pump bodies, and expansion joints.
- D. Glass fiber insulated pipes conveying fluids below ambient temperature:
 - 1. Provide vapor barrier jackets, factory-applied or field-applied. Secure with self-sealing longitudinal laps and butt strips with pressure sensitive adhesive.

2. Insulate fittings, joints, and valves with molded insulation of like material and thickness as adjacent pipe. Finish with glass cloth and vapor barrier adhesive or PVC fitting covers.
- E. Glass fiber insulated pipes conveying fluids above ambient temperature:
 1. Provide standard jackets, with or without vapor barrier, factory-applied or field-applied. Secure with self-sealing longitudinal laps and butt strips with pressure sensitive adhesive.
 2. Insulate fittings, joints, and valves with insulation of like material and thickness as adjoining pipe. Finish with glass cloth and adhesive or PVC fitting covers.
- F. Inserts and Shields:
 1. Application: Piping 2-1/2 inches diameter or larger.
 2. Shields: Galvanized steel between pipe hangers or pipe hanger rolls and inserts.
 3. Insert Location: Between support shield and piping and under the finish jacket.
- G. Continue insulation through walls, sleeves, pipe hangers, and other pipe penetrations. Finish at supports, protrusions, and interruptions. At fire separations, refer to Firestopping Section.
- H. Exterior Applications: Provide vapor barrier jacket. Insulate fittings, joints, and valves with insulation of like material and thickness as adjoining pipe. Provide PVC jacket.

3.3 SCHEDULES

- A. Domestic Hot and Recirculated Hot Water in dwelling units:
 1. Glass Fiber Insulation:
 - a. Pipe Size Range: 3/4 inch and larger.
 - b. Thickness: As required to achieve minimum R-3.
- B. Domestic Hot and Recirculated Hot Water at clubhouse:
 1. Glass Fiber Insulation:
 - a. Pipe Size Range: 1-1/4 inch and smaller.
 - b. Thickness: 1 inch.
 2. Glass Fiber Insulation:
 - a. Pipe Size Range: Above 1-1/4 inch
 - b. Thickness: 1-1/2 inch
- C. Domestic Cold Water at clubhouse:
 1. Glass Fiber Insulation:
 - a. Pipe Size Range: 1/2 through 1-1/4 inch.
 - b. Thickness: 1/2 inch.
 2. Glass Fiber Insulation:
 - a. Pipe Size Range: Above 1-1/4 inch
 - b. Thickness: 1 inch
- D. Other Systems:
 1. Drains from water coolers: 1/2" elastomeric

END OF SECTION 220719

SECTION 221005
PLUMBING PIPING

PART 1 GENERAL

1.1 SECTION INCLUDES

- A. Pipe, pipe fittings, specialties, and connections for piping systems.
 - 1. Sanitary sewer.
 - 2. Domestic water.
 - 3. Flanges, unions, and couplings.
 - 4. Pipe hangers and supports.
 - 5. Valves.
 - 6. Flow controls.
 - 7. Check.
 - 8. Relief valves.
 - 9. Sleeves
 - 10. Sleeve seals
 - 11. Grout
 - 12. Escutcheons

1.2 RELATED REQUIREMENTS

- A. Section - Firestopping.
- B. Section 220553 - Identification for Plumbing Piping and Equipment.
- C. Section 220719 - Plumbing Piping Insulation.

1.3 REFERENCE STANDARDS

- A. ASME B16.18 - Cast Copper Alloy Solder Joint Pressure Fittings; 2012.
- B. ASME B16.22 - Wrought Copper and Copper Alloy Solder-Joint Pressure Fittings; 2013.
- C. ASME B31.9 - Building Services Piping; 2014.
- D. ASSE 1003 - Performance Requirements for Water Pressure Reducing Valves for Domestic Water Distribution Systems; 2009.
- E. ASTM A74 - Standard Specification for Cast Iron Soil Pipe and Fittings; 2015.
- F. ASTM B32 - Standard Specification for Solder Metal; 2008 (Reapproved 2014).
- G. ASTM B42 - Standard Specification for Seamless Copper Pipe, Standard Sizes; 2015a.
- H. ASTM B88 - Standard Specification for Seamless Copper Water Tube; 2014.
- I. ASTM B813 - Standard Specification for Liquid and Paste Fluxes for Soldering of Copper and Copper Alloy Tube; 2010.
- J. ASTM B828 - Standard Practice for Making Capillary Joints by Soldering of Copper and Copper Alloy Tube and Fittings; 2002 (Reapproved 2010).
- K. ASTM D2564 - Standard Specification for Solvent Cements for Poly(Vinyl Chloride) (PVC) Plastic Piping Systems; 2012.
- L. ASTM D2665 - Standard Specification for Poly(Vinyl Chloride) (PVC) Plastic Drain, Waste, and Vent Pipe and Fittings; 2014.
- M. ASTM D2729 - Standard Specification for Poly(Vinyl Chloride) (PVC) Sewer Pipe and Fittings; 2011.
- N. ASTM D2855 - Standard Practice for Making Solvent-Cemented Joints with Poly(Vinyl Chloride) (PVC) Pipe and Fittings; 1996 (Reapproved 2010).
- O. ASTM F876 - Standard Specification for Crosslinked Polyethylene (PEX) Tubing; 2013a.
- P. ASTM F877 - Standard Specification for Crosslinked Polyethylene (PEX) Plastic Hot- and Cold-Water Distribution Systems; 2011.

- Q. ASTM F708 - Standard Practice for Design and Installation of Rigid Pipe Hangers; 1992 (Reapproved 2008).
 - R. ASTM F 2389-17a - Standard Specification for Pressure-rated Polypropylene (PP) Piping Systems
 - S. CSA B137.11 - Polypropylene (PP-R) Pipe and Fittings for Pressure Applications
 - T. NSF/ANSI 14 - Plastic Piping System Components and Related Materials
 - U. NSF/ANSI 61 - Drinking Water Systems Components - Health Effects
 - V. AWWA C111/A21.11 - Rubber-Gasket Joints for Ductile-Iron Pressure Pipe and Fittings; 2012.
 - W. AWWA C151/A21.51 - Ductile-Iron Pipe, Centrifugally Cast; 2009.
 - X. AWWA C550 - Protective Interior Coatings for Valves and Hydrants; 2013.
 - Y. AWWA C651 - Disinfecting Water Mains; 2005.
 - Z. CISPI 301 - Standard Specification for Hubless Cast Iron Soil Pipe and Fittings for Sanitary and Storm Drain, Waste and Vent Piping Applications; 2009.
 - AA. CISPI 310 - Specification for Coupling for Use in Connection with Hubless Cast Iron Soil Pipe and Fittings for Sanitary and Storm Drain, Waste, and Vent Piping Applications; 2011.
 - AB. ICC-ES AC01 - Acceptance Criteria for Expansion Anchors in Masonry Elements; 2012.
 - AC. MSS SP-58 - Pipe Hangers and Supports - Materials, Design, Manufacture, Selection, Application, and Installation; 2009.
 - AD. MSS SP-67 - Butterfly Valves; 2011.
 - AE. MSS SP-70 - Cast Iron Gate Valves, Flanged and Threaded Ends; 2011.
 - AF. MSS SP-71 - Cast Iron Swing Check Valves, Flanged and Threaded Ends; 2011.
 - AG. MSS SP-78 - Cast Iron Plug Valves, Flanged and Threaded Ends; 2011.
 - AH. MSS SP-80 - Bronze Gate, Globe, Angle and Check Valves; 2013.
 - AI. MSS SP-110 - Ball Valves Threaded, Socket-Welding, Solder Joint, Grooved and Flared Ends; 2010.
 - AJ. NSF 372 - Drinking Water System Components - Lead Content; 2011.
- 1.4 SUBMITTALS
- A. See Administrative Requirements, for submittal procedures.
 - B. Product Data: Provide data on pipe materials, pipe fittings, valves, and accessories. Provide manufacturers catalog information. Indicate valve data and ratings.
 - C. Project Record Documents: Record actual routing of piping. Record actual locations of valves.
- 1.5 QUALITY ASSURANCE
- A. Perform Work in accordance with City of Aurora standards.
 - B. Where joining systems specific to a piping manufacturer are used, personnel shall receive factory authorized training prior to installation, and submit evidence of such training for review.
 - C. Valves: Manufacturer's name and pressure rating marked on valve body.
 - D. Welding Materials and Procedures: Comply with ASME BPVC-IX and applicable state labor regulations.
 - E. Welder Qualifications: Certified in accordance with ASME BPVC-IX.
 - F. Identify pipe with marking including size, ASTM material classification, ASTM specification, potable water certification, water pressure rating.
- 1.6 REGULATORY REQUIREMENTS
- A. Perform Work in accordance with State of Colorado, plumbing code.
 - B. Conform to applicable code for installation of backflow prevention devices.

1.7 DELIVERY, STORAGE, AND HANDLING

- A. Accept valves on site in shipping containers with labeling in place. Inspect for damage.
- B. Provide temporary protective coating on cast iron and steel valves.
- C. Provide temporary end caps and closures on piping and fittings. Maintain in place until installation.
- D. Protect piping systems from entry of foreign materials by temporary covers, completing sections of the work, and isolating parts of completed system.

1.8 FIELD CONDITIONS

- A. Do not install underground piping when bedding is wet or frozen.

PART 2 PRODUCTS

2.1 GENERAL REQUIREMENTS

- A. Potable Water Supply Systems: Provide piping, pipe fittings, and solder and flux (if used), that comply with NSF 61 and NSF 372 for maximum lead content; label pipe and fittings.
- B. Reference PART 3 EXECUTION for product applications. Listing of products herein does not imply acceptance of use in all sizes or locations.

2.2 SANITARY SEWER PIPING, BURIED WITHIN 5 FEET OF BUILDING

- A. PVC Pipe: ASTM D2665 or ASTM D3034.
 - 1. Fittings: PVC.
 - 2. Joints: Solvent welded, with ASTM D2564 solvent cement.

2.3 SANITARY SEWER PIPING, ABOVE GRADE

- A. Cast Iron Pipe: CISPI 301, hubless, service weight.
 - 1. Fittings: Cast iron.
 - 2. Joints: CISPI 310, neoprene gaskets and stainless steel clamp-and-shield assemblies.
- B. PVC Pipe: ASTM D2729.
 - 1. Fittings: PVC.
 - 2. Joints: Solvent welded, with ASTM D2564 solvent cement.

2.4 WATER PIPING, BURIED WITHIN 5 FEET OF BUILDING

- A. Copper Pipe: ASTM B42, Type K, hard drawn.
 - 1. Fittings: ASME B16.18, cast copper alloy or ASME B16.22 wrought copper and bronze.
 - 2. Joints: ASTM B 32, alloy Sn95 solder.
- B. Ductile Iron Pipe: AWWA C151/A21.51.
 - 1. Fittings: Ductile or gray iron, standard thickness.
 - 2. Joints: AWWA C111/A21.11, styrene butadiene rubber (SBR) or vulcanized SBR gasket with 3/4 inch diameter rods.

2.5 DOMESTIC WATER PIPING, ABOVE GRADE

- A. Copper Tube: ASTM B88 (ASTM B88M), Type L (B), Drawn (H).
 - 1. Fittings: ASME B16.18, cast copper alloy or ASME B16.22, wrought copper and bronze.
 - 2. Joints: ASTM B32, alloy Sn95 solder.
- B. Polyethylene Pipe (PEX): ASTM F 1281 or ASTM F 1282, tested for potable water and residual chlorine use.
 - 1. Fittings and Joints: Brass compression type.
- C. Polypropylene Pipe (PP-R): Pipe and fittings shall be manufactured from a beta crystalline PP-RCT resin meeting the short-term properties and long-term strength requirements of ASTM F 2389 and CSA B137.11. Pipe and fittings made from a PP-RCT (PPRP) material that is made from a terpolymer, or made from standard PPR material are unacceptable. All pipe and fitting material shall be pigmented as solid steel grey in color, except for any outside UV protective layer, which may be black or white.

1. Pipe shall be equivalent to Niron Clima Pipe and shall be listed for potable water (shall have listings to NSF 14 and 61g), regardless of the whether the pipe and fittings are to be used for potable water service or HVAC service. All pipe shall be made in an extrusion process and shall be pigmented as solid steel grey in color. The piping shall be extruded with a middle layer that has glass fiber content to restrict thermal expansion.
 2. Fittings shall be manufactured from a PP-RCT resin meeting the short-term properties and long-term strength requirements of ASTM F 2389. All fittings shall comply with NSF 14, ASTM F 2389 and CSA B137.11. Fittings shall be Niron PP-RCT piping as manufactured by Nupi Americas of Houston, TX.
 3. Fittings may be either socket fusion through nominal 5 inch (125 mm), electrofusion through 8 inch (200mm) or butt fusion in nominal 2 inch through 24 inch sizes (63mm through 630 mm). Electrofusion may also be performed in nominal sizes 10 inch through 24 inch (250mm through 630mm) by means of the use of electrofusion couplings as applied on butt fusion fittings and pipe.
 4. Pipe and fittings shall be covered by a factory warranty for 30 years to be free of defects in materials or manufacturing.
 5. Where standard pipe insulation is indicated on the drawings or in these specifications, the contractor shall provide a thermal (radiant, conductive, and convective) and vapor barrier insulation. The insulation products shall be provided in appropriate thickness or as indicated on the drawings or elsewhere in these specifications.
- D. Mechanical joint system: Manufacturer's fittings and joining methods, for pipe materials and sizes.
1. Viega

2.6 FLANGES, UNIONS, AND COUPLINGS

- A. Unions for Pipe Sizes 3 Inches and Under:
1. Ferrous Pipe: Class 150 malleable iron threaded unions.
 2. Copper Tube and Pipe: Class 150 bronze unions with soldered joints.
- B. Dielectric Connections: Union with galvanized or plated steel threaded end, copper solder end, water impervious isolation barrier.

2.7 PIPE HANGERS AND SUPPORTS

- A. Provide hangers and supports that comply with MSS SP-58.
1. If type of hanger or support for a particular situation is not indicated, select appropriate type using MSS SP-58 recommendations.
 2. Overhead Supports: Individual steel rod hangers attached to structure or to trapeze hangers.
 3. Trapeze Hangers: Welded steel channel frames attached to structure.
 4. Vertical Pipe Support: Steel riser clamp.
- B. Plumbing Piping - Drain, Waste, and Vent:
1. Conform to ASME B31.9.
 2. Hangers for Pipe Sizes 1/2 Inch to 1-1/2 Inches: Malleable iron, adjustable swivel, split ring.
 3. Hangers for Pipe Sizes 2 Inches and Over: Carbon steel, adjustable, clevis.
 4. Multiple or Trapeze Hangers: Steel channels with welded spacers and hanger rods.
 5. Wall Support for Pipe Sizes to 3 Inches: Cast iron hook.
 6. Wall Support for Pipe Sizes 4 Inches and Over: Welded steel bracket and wrought steel clamp.
 7. Vertical Support: Steel riser clamp.
- C. Plumbing Piping - Water:
1. Conform to ASME B31.9.
 2. Hangers for Pipe Sizes 1/2 Inch to 1-1/2 Inches: Malleable iron, adjustable swivel, split ring.
 3. Hangers for Cold Pipe Sizes 2 Inches and Over: Carbon steel, adjustable, clevis.
 4. Hangers for Hot Pipe Sizes 2 Inches to 4 Inches: Carbon steel, adjustable, clevis.
 5. Multiple or Trapeze Hangers: Steel channels with welded supports or spacers and hanger rods.
 6. Multiple or Trapeze Hangers for Hot Pipe Sizes 6 Inches and Over: Steel channels with welded supports or spacers and hanger rods, cast iron roll.
 7. Wall Support for Pipe Sizes to 3 Inches: Cast iron hook.

8. Wall Support for Pipe Sizes 4 Inches and Over: Welded steel bracket and wrought steel clamp.
9. Vertical Support: Steel riser clamp.

D. Hanger Fasteners: Attach hangers to structure using appropriate fasteners, as follows:

1. Masonry Wedge Expansion Anchors: Complying with ICC-ES AC01.
2. Other Types: As required.

2.8 GATE VALVES

A. Manufacturers:

1. Tyco Flow Control: www.tycoflowcontrol.com.
2. Conbraco Industries: www.conbraco.com.
3. Nibco, Inc: www.nibco.com.
4. Milwaukee Valve Company: www.milwaukeevalve.com.

B. Up To and Including 3 Inches:

1. 1, Class 125, bronze body, bronze trim, rising stem, handwheel, inside screw, solid wedge disc, solder ends.

C. 2 Inches and Larger:

1. 1, Class 125, iron body, bronze trim, outside screw and yoke, handwheel, solid wedge disc, flanged ends. Provide chain-wheel operators for valves 6 inches and larger mounted over 8 feet above floor.

2.9 BALL VALVES

A. Manufacturers:

1. Tyco Flow Control: www.tycoflowcontrol.com.
2. Conbraco Industries: www.conbraco.com.
3. Nibco, Inc: www.nibco.com.
4. Milwaukee Valve Company: www.milwaukeevalve.com.

B. Construction, 4 Inches and Smaller: MSS SP-110, Class 150, 400 psi CWP, bronze, two piece body, chrome plated brass ball, regular port, teflon seats and stuffing box ring, blow-out proof stem, lever handle with balancing stops, solder ends with union.

2.10 PLUG VALVES

A. Construction 2-1/2 Inches and Larger: 1, 175 psi CWP, cast iron body and plug, pressure lubricated, teflon or Buna N packing, flanged or grooved ends. Provide lever operator with set screw.

2.11 BUTTERFLY VALVES

A. Manufacturers:

1. Tyco Flow Control: www.tycoflowcontrol.com.
2. Hammond Valve: www.hammondvalve.com.
3. Crane Co.: www.cranevalve.com.
4. Milwaukee Valve Company: www.milwaukeevalve.com.
5. Substitutions: See Section 016000 - Product Requirements.

B. Construction 1-1/2 Inches and Larger: MSS SP-67, 200 psi CWP, cast or ductile iron body, nickel-plated ductile iron disc, resilient replaceable EPDM seat, wafer ends, extended neck, 10 position lever handle.

C. Provide gear operators for valves 8 inches and larger, and chain-wheel operators for valves mounted over 8 feet above floor.

2.12 FLOW CONTROLS

A. Manufacturers:

1. Tyco Flow Control: www.tycoflowcontrol.com.
2. ITT Bell & Gossett: www.bellgossett.com.
3. Griswold Controls: www.griswoldcontrols.com.
4. Taco, Inc: www.taco-hvac.com.

- B. Construction: Class 125, Brass or bronze body with union on inlet and outlet, temperature and pressure test plug on inlet and outlet, blowdown/backflush drain.
- C. Calibration: Control flow within 5 percent of selected rating, over operating pressure range of 10 times minimum pressure required for control, maximum minimum pressure 3.5 psi.

2.13 SWING CHECK VALVES

- A. Manufacturers:
 - 1. Tyco Flow Control: www.tycoflowcontrol.com.
 - 2. Hammond Valve: www.hammondvalve.com.
 - 3. Nibco, Inc: www.nibco.com.
 - 4. Milwaukee Valve Company: www.milwaukeevalve.com.
 - 5. Substitutions: See Section 016000 - Product Requirements.
- B. Up to 2 Inches:
 - 1. 1, Class 125, bronze body and cap, bronze swing disc with rubber seat, solder ends.
- C. Over 2 Inches:
 - 1. 1, Class 125, iron body, bronze swing disc, renewable disc seal and seat, flanged or grooved ends.

2.14 SPRING LOADED CHECK VALVES

- A. Manufacturers:
 - 1. Tyco Flow Control: www.tycoflowcontrol.com.
 - 2. Hammond Valve: www.hammondvalve.com.
 - 3. Crane Co.: www.cranvalve.com.
 - 4. Milwaukee Valve Company: www.milwaukeevalve.com.
- B. Class 125, iron body, bronze trim, stainless steel springs, bronze disc, Buna N seals, wafer style ends.

2.15 WATER PRESSURE REDUCING VALVES

- A. Manufacturers:
 - 1. Amtrol Inc: www.amtrol.com.
 - 2. Cla-Val Co: www.cla-val.com.
 - 3. Watts Regulator Company: www.wattsregulator.com.
- B. Up to 2 Inches:
 - 1. ASSE 1003, bronze body, stainless steel, and thermoplastic internal parts, fabric reinforced diaphragm, strainer, threaded single union ends.
- C. Over 2 Inches:
 - 1. ASSE 1003, cast iron body with interior lining complying with AWWA C550, bronze fitted, elastomeric diaphragm and seat disc, flanged.

2.16 RELIEF VALVES

2.17 RELIEF VALVES

- A. Temperature and Pressure Relief:
 - 1. Manufacturers:
 - a. Cla-Val Co: www.cla-val.com.
 - b. Henry Technologies: www.henrytech.com.
 - c. Watts Regulator Company: www.wattsregulator.com.
 - 2. AGA Z21.22 certified, bronze body, teflon seat, stainless steel stem and springs, automatic, direct pressure actuated, temperature relief maximum 210 degrees F, capacity ASME (BPV IV) certified and labelled.

2.18 SLEEVES

- A. Galvanized-Steel-Pipe Sleeves: ASTM A 53/A 53M, Type E, Grade B, Schedule 40, zinc coated, with plain ends.

2.19 SLEEVE-SEAL SYSTEMS

- A. Manufacturers: Subject to compliance with requirements, available manufacturers offering products that may be incorporated into the Work include, but are not limited to, the following:
- B. Description: Modular sealing-element unit, designed for field assembly, for filling annular space between piping and sleeve.
 - 1. Sealing Elements: EPDM-rubber interlocking links shaped to fit surface of pipe. Include type and number required for pipe material and size of pipe.
 - 2. Pressure Plates: Carbon steel.
 - 3. Connecting Bolts and Nuts: Carbon steel, with corrosion-resistant coating, of length required to secure pressure plates to sealing elements.

2.20 GROUT

- A. Standard: ASTM C 1107/C 1107M, Grade B, post-hardening and volume-adjusting, dry, hydraulic-cement grout.
- B. Characteristics: Nonshrink; recommended for interior and exterior applications.
- C. Design Mix: 5000-psi, 28-day compressive strength.
- D. Packaging: Premixed and factory packaged.

2.21 ESCUTCHEONS

- A. One-Piece, Cast-Brass Type: With polished, chrome-plated finish and setscrew fastener.
- B. One-Piece, Deep-Pattern Type: Deep-drawn, box-shaped brass with chrome-plated finish and spring-clip fasteners.
- C. One-Piece, Stamped-Steel Type: With chrome-plated finish and spring-clip fasteners.
- D. Split-Casting Brass Type: With polished, chrome-plated finish and with concealed hinge and setscrew.
- E. Split-Plate, Stamped-Steel Type: With chrome-plated finish, exposed-rivet hinge, and spring-clip fasteners.

PART 3 EXECUTION

3.1 EXAMINATION

- A. Verify that excavations are to required grade, dry, and not over-excavated.

3.2 PREPARATION

- A. Ream pipe and tube ends. Remove burrs. Bevel plain end ferrous pipe.
- B. Remove scale and dirt, on inside and outside, before assembly.
- C. Prepare piping connections to equipment with flanges or unions.

3.3 INSTALLATION

- A. Install in accordance with manufacturer's instructions.
- B. Provide non-conducting dielectric connections wherever jointing dissimilar metals.
- C. Route piping in orderly manner and maintain gradient. Route parallel and perpendicular to walls.
- D. Install piping to maintain headroom, conserve space, and not interfere with use of space.
- E. Group piping whenever practical at common elevations.
- F. Install piping to allow for expansion and contraction without stressing pipe, joints, or connected equipment.
- G. Provide clearance in hangers and from structure and other equipment for installation of insulation and access to valves and fittings.
- H. Provide access where valves and fittings are not exposed.
- I. Install vent piping penetrating roofed areas to maintain integrity of roof assembly.

- J. Where pipe support members are welded to structural building framing, scrape, brush clean, and apply one coat of zinc-rich primer to welding.
- K. Provide support for utility meters in accordance with requirements of utility companies.
- L. TRENCHING
 - 1. Notify Architect of unexpected subsurface conditions and discontinue affected Work in area until notified to resume work.
 - 2. Slope banks of excavations deeper than 4 feet to angle of repose or less until shored.
 - 3. Do not interfere with 45 degree bearing splay of foundations.
 - 4. Cut trenches wide enough to allow inspection of installed utilities.
 - 5. Hand trim excavations. Remove loose matter.
 - 6. Remove large stones and other hard matter that could damage piping or impede consistent backfilling or compaction.
 - 7. Remove excavated material that is unsuitable for re-use from site.
 - 8. Remove excess excavated material from site.
- M. BACKFILLING
 - 1. Fill up to subgrade elevations unless otherwise indicated.
 - 2. Employ a placement method that does not disturb or damage other work.
 - 3. Systematically fill to allow maximum time for natural settlement. Do not fill over porous, wet, frozen or spongy subgrade surfaces.
 - 4. Maintain optimum moisture content of fill materials to attain required compaction density.
 - 5. Sand Fill: Place and compact materials in equal continuous layers not exceeding 6 inches compacted depth.
- N. Install valves with stems upright or horizontal, not inverted. Refer to Section 220523.
- O. Install water piping to ASME B31.9.
- P. Copper Pipe and Tube: Make soldered joints in accordance with ASTM B828, using specified solder, and flux meeting ASTM B813; in potable water systems use flux also complying with NSF 61 and NSF 372.
- Q. PVC Pipe: Make solvent-welded joints in accordance with ASTM D2855.
- R. Do not use PVC piping in return air plenums.
- S. PP Piping: Install fittings and joints using socket-fusion, electrofusion, or butt-fusion as applicable for the fitting type. All fusion-well joints shall be made in accordance with the pipe and fitting manufacturer's specifications and product standards.
- T. SLEEVE INSTALLATION
 - 1. Install sleeves for piping passing through penetrations in floors, partitions, roofs, and walls.
 - 2. For sleeves that will have sleeve-seal system installed, select sleeves of size large enough to provide 1-inch annular clear space between piping and concrete slabs and walls.
 - a. Sleeves are not required for core-drilled holes.
 - 3. Install sleeves in concrete floors, concrete roof slabs, and concrete walls as new slabs and walls are constructed.
 - a. Permanent sleeves are not required for holes in slabs formed by molded-PE or -PP sleeves.
 - b. Cut sleeves to length for mounting flush with both surfaces.
 - 1) Exception: Extend sleeves installed in floors of mechanical equipment areas or other wet areas 2 inches above finished floor level.
 - c. Using grout, seal the space outside of sleeves in slabs and walls without sleeve-seal system.
 - 4. Install sleeves for pipes passing through interior partitions.
 - a. Cut sleeves to length for mounting flush with both surfaces.
 - b. Install sleeves that are large enough to provide 1/4-inch annular clear space between sleeve and pipe or pipe insulation.

- c. Seal annular space between sleeve and piping or piping insulation; use joint sealants appropriate for size, depth, and location of joint. Comply with requirements for sealants specified in other sections.
- 5. Fire-Barrier Penetrations: Maintain indicated fire rating of walls, partitions, ceilings, and floors at pipe penetrations. Seal pipe penetrations with firestop materials. Comply with requirements for firestopping specified in other sections.

U. SLEEVE-SEAL-SYSTEM INSTALLATION

- 1. Install sleeve-seal systems in sleeves in exterior concrete walls and slabs-on-grade at service piping entries into building.
- 2. Select type, size, and number of sealing elements required for piping material and size and for sleeve ID or hole size. Position piping in center of sleeve. Center piping in penetration, assemble sleeve-seal system components, and install in annular space between piping and sleeve. Tighten bolts against pressure plates that cause sealing elements to expand and make a watertight seal.

V. ESCUTCHEONS

- 1. Install escutcheons for piping penetrations of walls, ceilings, and finished floors.
- 2. Install escutcheons with ID to closely fit around pipe, tube, and insulation of insulated piping and with OD that completely covers opening.
 - a. Escutcheons Schedule:
 - 1) Piping with Fitting or Sleeve Protruding from Wall: One-piece, deep-pattern type.
 - 2) Insulated Piping: One-piece, stamped-steel type or split-plate, stamped-steel type with exposed-rivet hinge.
 - 3) Bare Piping at Wall and Floor Penetrations in Finished Spaces: One-piece, cast-brass or split-casting brass type with polished, chrome-plated finish.
 - 4) Bare Piping at Ceiling Penetrations in Finished Spaces: One-piece, cast-brass or split-casting brass type with polished, chrome-plated finish.
 - 5) Bare Piping in Unfinished Service Spaces: One-piece, stamped-steel type or split-plate, stamped-steel type with exposed-rivet hinge.
 - 6) Bare Piping in Equipment Rooms: One-piece, stamped-steel type or split-plate, stamped-steel type with exposed-rivet hinge.

W. Inserts:

- 1. Provide inserts for placement in concrete formwork.
- 2. Provide inserts for suspending hangers from reinforced concrete slabs and sides of reinforced concrete beams.
- 3. Provide hooked rod to concrete reinforcement section for inserts carrying pipe over 4 inches.
- 4. Where concrete slabs form finished ceiling, locate inserts flush with slab surface.

X. Pipe Hangers and Supports:

- 1. Install in accordance with ASME B31.9.
- 2. Support horizontal piping as indicated.
- 3. Install hangers to provide minimum 1/2 inch space between finished covering and adjacent work.
- 4. Place hangers within 12 inches of each horizontal elbow.
- 5. Use hangers with 1-1/2 inch minimum vertical adjustment. Design hangers for pipe movement without disengagement of supported pipe.
- 6. Where several pipes can be installed in parallel and at same elevation, provide multiple or trapeze hangers.
- 7. Provide copper plated hangers and supports for copper piping.
- 8. Provide hangers adjacent to motor-driven equipment with vibration isolation; refer to Section 220548.
- 9. Support cast iron drainage piping at every joint.

3.4 APPLICATION

- A. Install unions downstream of valves and at equipment or apparatus connections.
- B. Install brass male adapters each side of valves in copper piped system. Solder adapters to pipe.

- C. Install gate valves for shut-off and to isolate equipment, part of systems, or vertical risers.
- D. Provide spring-loaded check valves on discharge of water pumps.
- E. Provide flow controls in water recirculating systems where indicated.

3.5 TOLERANCES

- A. Drainage Piping: Establish invert elevations within 1/2 inch vertically of location indicated and slope to drain at minimum of 1/8 inch per foot slope.

3.6 DISINFECTION OF DOMESTIC WATER PIPING SYSTEM

- A. Prior to starting work, verify system is complete, flushed, and clean.
- B. Ensure acidity (pH) of water to be treated is between 7.4 and 7.6 by adding alkali (caustic soda or soda ash) or acid (hydrochloric).
- C. Inject disinfectant, free chlorine in liquid, powder, tablet, or gas form throughout system to obtain 50 to 80 mg/L residual.
- D. Bleed water from outlets to ensure distribution and test for disinfectant residual at minimum 15 percent of outlets.
- E. Maintain disinfectant in system for 24 hours.
- F. If final disinfectant residual tests less than 25 mg/L, repeat treatment.
- G. Flush disinfectant from system until residual equal to that of incoming water or 1.0 mg/L.
- H. Take samples no sooner than 24 hours after flushing, from 10 percent of outlets and from water entry, and analyze in accordance with AWWA C651.

3.7 SCHEDULES

- A. Pipe Hanger Spacing:
 - 1. Metal Piping:
 - a. Pipe Size: 1/2 inches to 1-1/4 inches:
 - 1) Maximum Hanger Spacing: 6.5 ft.
 - 2) Hanger Rod Diameter: 3/8 inches.
 - b. Pipe Size: 1-1/2 inches to 2 inches:
 - 1) Maximum Hanger Spacing: 10 ft.
 - 2) Hanger Rod Diameter: 3/8 inch.
 - c. Pipe Size: 2-1/2 inches to 3 inches:
 - 1) Maximum Hanger Spacing: 10 ft.
 - 2) Hanger Rod Diameter: 1/2 inch.
 - d. Pipe Size: 4 inches to 6 inches:
 - 1) Maximum Hanger Spacing: 10 ft.
 - 2) Hanger Rod Diameter: 5/8 inch.
 - 2. Plastic Piping:
 - a. All Sizes:
 - 1) Maximum Hanger Spacing: 6 ft.
 - 2) Hanger Rod Diameter: 3/8 inch.
- B. Pipe Materials:
 - 1. Domestic Water:
 - a. Basis of design is copper. If PEX is used, sizes shall be adjusted to provide equivalent hydraulic diameter.
 - b. Any materials listed for use in Part 2.
 - c. Stubouts to fixtures shall be copper.
 - 2. Sanitary Drain and Vent: Any material listed for use in Part 2.
 - a. PVC shall not be used in return air plenums.

END OF SECTION 221005

SECTION 221006
PLUMBING PIPING SPECIALTIES

PART 1 GENERAL

1.1 SECTION INCLUDES

- A. Cleanouts.
- B. Backflow preventers.
- C. Double check valve assemblies.
- D. Water hammer arrestors.
- E. Mixing valves.
- F. Interceptors.
- G. Thermostatic mixing valves.

1.2 REFERENCE STANDARDS

- A. ADA Standards - Americans with Disabilities Act (ADA) Standards for Accessible Design; 2010.
- B. ASSE 1012 - Backflow Preventer with Intermediate Atmospheric Vent; 2009.
- C. ASSE 1013 - Reduced Pressure Principle Backflow Preventers and Reduced Pressure Principle Fire Protection Backflow Preventers; 2011.
- D. NSF 61 - Drinking Water System Components - Health Effects; 2014 (Errata 2015).
- E. NSF 372 - Drinking Water System Components - Lead Content; 2011.
- F. PDI-WH 201 - Water Hammer Arresters; 2010.

1.3 SUBMITTALS

- A. See Section 013000 - Administrative Requirements, for submittal procedures.
- B. Product Data: Provide component sizes, rough-in requirements, service sizes, and finishes.
- C. Certificates: Certify that grease interceptors meet or exceed specified requirements.

PART 2 PRODUCTS

2.1 GENERAL REQUIREMENTS

- A. Specialties in Potable Water Supply Systems: Provide products that comply with NSF 61 and NSF 372 for maximum lead content.

2.2 CLEANOUTS

- A. Manufacturers:
 - 1. Jay R. Smith Manufacturing Company; _____: www.jayrsmith.com/#sle.
 - 2. Josam Company; _____: www.josam.com/#sle.
 - 3. Zurn Industries, LLC; _____: www.zurn.com/#sle.
 - 4. Sioux Chief Manufacturing.
- B. Cleanouts at Exterior Surfaced Areas:
 - 1. Round cast nickel bronze access frame and non-skid cover.
- C. Cleanouts at Exterior Unsurfaced Areas:
 - 1. Line type with lacquered cast iron body and round epoxy coated gasketed cover.
- D. Cleanouts at Interior Finished Floor Areas (FFCO):
 - 1. Lacquered cast iron body with anchor flange, reversible clamping collar, threaded top assembly, and round gasketed scored cover in service areas and round gasketed depressed cover to accept floor finish in finished floor areas.
- E. Cleanouts at Interior Finished Wall Areas (FWCO):
 - 1. Line type with lacquered cast iron body and round epoxy coated gasketed cover, and round stainless steel access cover secured with machine screw.

F. Cleanouts at Interior Unfinished Accessible Areas: Caulked or threaded type.

2.3 BACKFLOW PREVENTERS

A. All products to be approved by USC Foundation for Cross Connection Control and Hydraulic Research.

B. Manufacturers:

1. Apollo Valves: www.apollovalves.com/#sle.
2. Watts Regulator Company, a part of Watts Water Technologies; _____ :
www.wattsregulator.com/#sle.
3. Zurn Industries, Inc: www.zurn.com.

C. Reduced Pressure Backflow Preventers:

1. ASSE 1013; bronze body with bronze internal parts and stainless steel springs; two independently operating, spring loaded check valves; diaphragm type differential pressure relief valve located between check valves; third check valve that opens under back pressure in case of diaphragm failure; non-threaded vent outlet; assembled with two gate valves, strainer, and four test cocks.

2.4 DOUBLE CHECK VALVE ASSEMBLIES

A. Manufacturers:

1. Apollo Valves: www.apollovalves.com/#sle.
2. Watts Regulator Company, a part of Watts Water Technologies; _____ :
www.wattsregulator.com/#sle.
3. Zurn Industries, LLC: www.zurn.com/#sle.

B. Double Check Valve Assemblies:

1. ASSE 1012; Bronze body with corrosion resistant internal parts and stainless steel springs; two independently operating check valves with intermediate atmospheric vent.

2.5 WATER HAMMER ARRESTORS

A. Manufacturers:

1. Sioux Chief Manufacturing

B. Water Hammer Arrestors:

1. Stainless steel or Copper construction, piston type sized in accordance with PDI-WH 201, precharged suitable for operation in temperature range 34 to 250 degrees F and maximum 150 psi working pressure.

2.6 MIXING VALVES

A. Thermostatic Mixing Valves:

1. Accessories:
 - a. Check valve on inlets.
 - b. Volume control shut-off valve on outlet.
 - c. Stem thermometer on outlet.
 - d. Strainer stop checks on inlets.

PART 3 EXECUTION

3.1 INSTALLATION

A. Install in accordance with manufacturer's instructions.

B. Extend cleanouts to finished floor or wall surface. Lubricate threaded cleanout plugs with mixture of graphite and linseed oil. Ensure clearance at cleanout for rodding of drainage system.

C. Encase exterior cleanouts in concrete flush with grade.

D. Install floor cleanouts at elevation to accommodate finished floor.

E. Install approved portable water protection devices on plumbing lines where contamination of domestic water may occur.

F. Pipe relief from backflow preventer to nearest drain.

G. Install water hammer arrestors on cold water supply piping to flush valve or solenoid operated fixtures. .

- H. Install cleanouts at locations required by the International Plumbing Code (IPC), whether or not specifically indicated on the drawings. Such locations include, but are not limited to the following:
1. Base of waste or soil stacks.
 2. Junction of building drain and building sewer (utilize 2-way cleanout at this location).

END OF SECTION 221006

SECTION 223000
PLUMBING EQUIPMENT

PART 1 GENERAL

1.1 SECTION INCLUDES

- A. Diaphragm-type compression tanks.
- B. Water heaters.
- C. Pumps.
 - 1. Circulators.

1.2 REFERENCE STANDARDS

- A. ASME BPVC-VIII-1 - Boiler and Pressure Vessel Code, Section VIII, Division 1 - Rules for Construction of Pressure Vessels; 2015.

1.3 REFERENCE STANDARDS

- A. ASME BPVC-VIII-1 - Boiler and Pressure Vessel Code, Section VIII, Division 1 - Rules for Construction of Pressure Vessels; The American Society of Mechanical Engineers; 2013.
- B. ICC (IPC) - International Plumbing Code.
- C. UL 778 - Standard for Motor-Operated Water Pumps; Current Edition, Including All Revisions.

1.4 SUBMITTALS

- A. Product Data:
 - 1. Provide dimension drawings of water heaters indicating components and connections to other equipment and piping.
 - 2. Indicate pump type, capacity, power requirements.
 - 3. Provide certified pump curves showing pump performance characteristics with pump and system operating point plotted. Include NPSH curve when applicable.
 - 4. Provide electrical characteristics and connection requirements.
- B. Shop Drawings:
 - 1. Indicate dimensions of tanks, tank lining methods, anchors, attachments, lifting points, tappings, and drains.
- C. Project Record Documents: Record actual locations of components.
- D. Operation and Maintenance Data: Include operation, maintenance, and inspection data, replacement part numbers and availability, and service depot location and telephone number.
- E. Warranty Documentation: Submit manufacturer warranty and ensure that forms have been completed in Owner's name and registered with manufacturer.

1.5 QUALITY ASSURANCE

- A. Manufacturer Qualifications: Company specializing in manufacturing the type of products specified in this section, with minimum three years of documented experience.
- B. Identification: Provide pumps with manufacturer's name, model number, and rating/capacity identified by permanently attached label.
- C. Performance: Ensure pumps operate at specified system fluid temperatures without vapor binding and cavitation, are non-overloading in parallel or individual operation, operate within 25 percent of midpoint of published maximum efficiency curve.

1.6 CERTIFICATIONS

- A. Water Heaters: NSF approved.
- B. Hybrid Electric Water Heaters: UL listed and labeled ____.
- C. Products Requiring Electrical Connection: Listed and classified by Underwriters Laboratories Inc., as suitable for the purpose specified and indicated.

1.7 DELIVERY, STORAGE, AND HANDLING

- A. Provide temporary inlet and outlet caps. Maintain caps in place until installation.

1.8 WARRANTY

- A. Provide Ten year manufacturer warranty for domestic water heaters.

PART 2 PRODUCTS

2.1 WATER HEATER MANUFACTURERS

- A. A.O. Smith Water Products Co: www.hotwater.com.
- B. Rheem Manufacturing Company: www.rheem.com.

2.2 ELECTRIC WATER HEATERS

- A. Type: Automatic, hybrid electric heat pump, vertical storage.
- B. Electrical Characteristics:
 - 1. 208 volts, single phase.
- C. Tank: Glass lined welded steel, thermally insulated with 2" thick foam plastic; encased in corrosion-resistant steel jacket; baked-on enamel finish.
- D. Controls: Automatic water thermostat with externally adjustable temperature range, flanged or screw-in nichrome elements, enclosed controls and electrical junction box .
- E. Accessories: Provide:
 - 1. Water Connections: Brass.
 - 2. Dip tube: Brass.
 - 3. Drain Valve.
 - 4. Anode: Magnesium

2.3 DIAPHRAGM-TYPE COMPRESSION TANKS

- A. Manufacturers:
 - 1. Amtrol Inc: www.amtrol.com/#sle.
 - 2. ITT Bell & Gossett: www.bellgossett.com.
 - 3. Taco, Inc: www.taco-hvac.com.
- B. Construction: Welded steel, tested and stamped in accordance with ASME BPVC-VIII-1; supplied with National Board Form U-1, rated for working pressure of 125 psig, with flexible EPDM diaphragm sealed into tank, and steel legs or saddles.
- C. Accessories: Pressure gauge and air-charging fitting, tank drain; precharge to 12 psig.

2.4 IN-LINE CIRCULATOR PUMPS

- A. Casing: Bronze, rated for 125 psig working pressure, with stainless steel rotor assembly.
- B. Impeller: Bronze.
- C. Shaft: Alloy steel with integral thrust collar and two oil lubricated bronze sleeve bearings.
- D. Seal: Carbon rotating against a stationary ceramic seat.
- E. Drive: Flexible coupling.

PART 3 EXECUTION

3.1 INSTALLATION

- A. Install plumbing equipment in accordance with manufacturer's instructions, as required by code, and complying with conditions of certification, if any.
- B. Coordinate with plumbing piping and related electrical work to achieve operating system.
- C. Pumps:
 - 1. Provide line sized isolating valve and strainer on suction and line sized soft seated check valve and balancing valve on discharge.

2. Decrease from line size with long radius reducing elbows or reducers. Support piping adjacent to pump such that no weight is carried on pump casings. Provide supports under elbows on pump suction and discharge line sizes 4 inches and over.
3. Ensure pumps operate at specified system fluid temperatures without vapor binding and cavitation, are non-overloading in parallel or individual operation, and operate within 25 percent of midpoint of published maximum efficiency curve.

END OF SECTION 223000

SECTION 224000
PLUMBING FIXTURES

PART 1 GENERAL

1.1 SECTION INCLUDES

- A. Fixtures

1.2 RELATED REQUIREMENTS

- A. Section 221005 - Plumbing Piping.
- B. Section 221006 - Plumbing Piping Specialties.

1.3 REFERENCE STANDARDS

- A. ASHRAE Std 18 - Methods of Testing for Rating Drinking-Water Coolers with Self-Contained Mechanical Refrigeration; 2008.
- B. ASME A112.6.1M - Supports for Off-the-Floor Plumbing Fixtures for Public Use; 1997 (Reaffirmed 2002).
- C. ASME A112.18.1 - Plumbing Supply Fittings; 2012.
- D. ASME A112.19.2 - Ceramic Plumbing Fixtures; 2013.
- E. ASME A112.19.3 - Stainless Steel Plumbing Fixtures (Designed for Residential Use); 2008 (R2013).
- F. ASME A112.19.5 - Flush Valves and Spuds for Water Closets, Urinals, and Tanks; 2011.
- G. NSF 61 - Drinking Water System Components - Health Effects; 2014 (Errata 2015).
- H. NSF 372 - Drinking Water System Components - Lead Content; 2011.

1.4 SUBMITTALS

- A. See Division 1 Section - Administrative Requirements, for submittal procedures.
- B. Product Data: Provide catalog illustrations of fixtures, sizes, rough-in dimensions, utility sizes, trim, and finishes.
- C. Manufacturer's Instructions: Indicate installation methods and procedures.
- D. Maintenance Data: Include fixture trim exploded view and replacement parts lists.
- E. Warranty: Submit manufacturer warranty and ensure forms have been completed in Owner's name and registered with manufacturer.
- F. Maintenance Materials: Furnish the following for Owner's use in maintenance of project.
 - 1. Extra Faucet Washers: Two sets of each type and size.
 - 2. Flush Valve Service Kits: Two for each type and size.

1.5 DELIVERY, STORAGE, AND HANDLING

- A. Accept fixtures on site in factory packaging. Inspect for damage.
- B. Protect installed fixtures from damage by securing areas and by leaving factory packaging in place to protect fixtures and prevent use.

1.6 WARRANTY

- A. Provide five year manufacturer warranty for electric water cooler.

PART 2 PRODUCTS

2.1 GENERAL REQUIREMENTS

- A. Potable Water Systems: Provide plumbing fittings and faucets that comply with NSF 61 and NSF 372 for maximum lead content; label pipe and fittings.

2.2 FIXTURES

- A. Scheduled on drawings

- B. Substitutions permitted, provided products are functionally and materially equivalent to those scheduled. Substitutions must be approved by Engineer.

PART 3 EXECUTION

3.1 EXAMINATION

- A. Verify that walls and floor finishes are prepared and ready for installation of fixtures.
- B. Verify that electric power is available and of the correct characteristics.
- C. Confirm that millwork is constructed with adequate provision for the installation of counter top lavatories and sinks.

3.2 PREPARATION

- A. Rough-in fixture piping connections in accordance with minimum sizes indicated in fixture rough-in schedule for particular fixtures.

3.3 INSTALLATION

- A. Install each fixture with trap, easily removable for servicing and cleaning.
- B. Provide chrome plated rigid or flexible supplies to fixtures with loose key stops, reducers, and escutcheons.
- C. Install components level and plumb.
- D. Install and secure fixtures in place with wall supports and bolts.
- E. Seal fixtures to wall and floor surfaces with sealant, color to match fixture.

3.4 INTERFACE WITH WORK OF OTHER SECTIONS

- A. Review millwork shop drawings. Confirm location and size of fixtures and openings before rough-in and installation.

3.5 ADJUSTING

- A. Adjust stops or valves for intended water flow rate to fixtures without splashing, noise, or overflow.

3.6 CLEANING

- A. Clean plumbing fixtures and equipment.

3.7 PROTECTION

- A. Protect installed products from damage due to subsequent construction operations.
- B. Do not permit use of fixtures by construction personnel.
- C. Repair or replace damaged products before Date of Substantial Completion.

3.8 SCHEDULES

- A. On Drawings

END OF SECTION 224000

SECTION 230533
HEAT TRACE CABLE

PART 1 GENERAL

1.1 SECTION INCLUDES

- A. Self-regulating parallel resistance electric heating cable.

1.2 RELATED REQUIREMENTS

- A. Section 230553 - Identification for HVAC Piping and Equipment.
- B. Section 230719 - HVAC Piping Insulation.
- C. Section 260519 - Low-Voltage Electrical Power Conductors and Cables.
- D. Section 260526 - Grounding and Bonding for Electrical Systems.
- E. Section 260533.13 - Conduit for Electrical Systems.
- F. Section 260533.16 - Boxes for Electrical Systems.
- G. Section 260583 - Wiring Connections.

1.3 REFERENCE STANDARDS

- A. IEEE 515.1 - IEEE Standard for the Testing, Design, Installation, and Maintenance of Electrical Resistance Trace Heating for Commercial Applications; 2012.
- B. ITS (DIR) - Directory of Listed Products; current edition.

1.4 ADMINISTRATIVE REQUIREMENTS

- A. Sequencing: Ensure that utility connections are achieved in an orderly and expeditious manner.
- B. Coordinate the work with other trades to provide ground fault protection for electric heat tracing circuits as required by NFPA 70.
- C. Coordinate the work with other trades to provide circuit breaker ratings suitable for installed circuit lengths.

1.5 SUBMITTALS

- A. See Section 013000 - Administrative Requirements, for submittal procedures.
- B. Product Data: Provide data for electric heat tracing.
- C. Shop Drawings: Indicate electric heat tracing layout, electrical terminations, thermostats, controls, and branch circuit connections.
- D. Manufacturer's Installation Instructions: Indicate installation instructions and recommendations.
- E. Field Quality Control Submittals: Indicate test reports and inspection reports.
- F. Project Record Documents: Record actual locations of electric heat tracing lines and thermostats.

1.6 QUALITY ASSURANCE

- A. Manufacturer Qualifications: Company specializing in manufacturing products specified in this section with at least three years of documented experience.
- B. Installer Qualifications: Company specializing in performing work of the type specified and with at least three years of documented experience.

PART 2 PRODUCTS

2.1 SELF-REGULATING PARALLEL RESISTANCE ELECTRIC HEATING CABLE

- A. Provide products listed, classified, and labeled by UL (DIR), ITS (DIR), or testing firm acceptable to authorities having jurisdiction (AHJ).
- B. Factory Rating and Testing: Comply with IEEE 515.1.
- C. Heating Element:

1. Provide pair of parallel tinned or nickel coated stranded copper bus wires embedded in cross linked conductive polymer core with varying heat output in response to temperature along its length.
 2. Terminations: Waterproof, factory assembled, non-heating leads with connector at one end and water-tight seal at opposite end.
 3. Capable of crossing over itself without overheating.
- D. Insulated Jacket: Flame retardant polyolefin.
- E. Cable Cover: Provide tinned copper and polyolefin outer jacket with UV inhibitor.
- F. Maximum Power-On Operating Temperature: 150 degrees F.
- G. Maximum Power-Off Exposure Temperature: 185 degrees F.
- H. Electrical Characteristics: as required for application.
- 2.2 OUTER JACKET MARKINGS
- A. Name of manufacturer, trademark, or other recognized symbol of identification.
 - B. Catalog number, reference number, or model.
 - C. Month and year of manufacture, date coding, applicable serial number, or equivalent.
 - D. Agency listing or approval.
 - E. Any applicable warning/caution statements such as "WARNING: De-energize circuit before removing cover.
- 2.3 CONNECTION KITS
- A. Provide power connection, splice/tee, and end seal kits compatible with the heating cable and without requiring cutting of the cable core to expose bus wires.
 - B. Furnish with NEMA 4X rating for prevention of corrosion and water ingress.
- 2.4 ACCESSORIES
- A. Provide Accessories As Indicated or As Required for Complete Installation, Including but Not Limited To:
 1. High temperature, glass filament tape for attachment of heating cable to metal piping.
 2. Aluminum self-adhesive tape for attachment of heating cable to plastic piping.
 3. Heat-conductive putty.
 4. Cable ties.
 5. Silicone end seals and splice kits.
 6. Installation clips.
- 2.5 CONTROLS
- A. Pipe Mounted Thermostats:
 1. Remote bulb unit with adjustable temperature range from 30 to 50 degrees F.
 2. Snap-action, open-on-rise, single pole switch with minimum current rating adequate for the connected cable.
 3. Remote bulb on capillary, resistance temperature device (RTD) or thermistor for direct sensing of pipe wall temperature.
 4. Control Enclosure: Corrosion resistant and waterproof.
 - B. Provide minimum 30 ampere contactor to indicate operational status and on/off control.

PART 3 EXECUTION

3.1 EXAMINATION

- A. Verify that piping and equipment are ready to receive work.
- B. Verify field measurements are as indicated on shop drawings.
- C. Verify required power is available, in proper location, and ready for use.

3.2 PREPARATION

- A. Clean all surfaces prior to installation.
- B. Prepare surfaces using the methods recommended by the manufacturer.

3.3 INSTALLATION

- A. Install in accordance with manufacturer's recommendations.
- B. Comply with installation requirements of IEEE 515.1 and NFPA 70, Article 427.
- C. Apply heating cable linearly on pipe with fiberglass tape only after piping has successfully completed any required pressure testing.
- D. Comply with all national and local code requirements.
- E. Install controls in accordance with manufacturer's recommendations.
- F. Identification:
 - 1. After thermal insulation installation, apply external pipeline decals to indicate presence of the thermal insulation cladding at intervals not to exceed 20 ft including cladding over each valve or other equipment that may require maintenance.
- G. Equipment Wiring: Refer to Section 260583.
- H. Electrical Connections: Refer to Section 260519.

3.4 FIELD QUALITY CONTROL

- A. Field Testing and Inspections:
 - 1. Commission system in accordance with installation and operation manual.
 - 2. Inspect for sources of water entry and proper sealing.
 - 3. Inspect weather barrier to confirm that no sharp edges are contacting the trace heating.
 - 4. Minimum Acceptable Insulation Resistance: 20 megohms or greater at a test voltage of 2500 VDC for polymer insulated trace heaters.
 - 5. Test heating cable integrity with megohmmeter at the following intervals:
 - 6. Measure voltage and current at each unit.
 - 7. Controls:
 - a. Verify control parameters are set to the application requirements.

END OF SECTION 230533

SECTION 230593
TESTING, ADJUSTING, AND BALANCING FOR HVAC

PART 1 GENERAL

1.1 SECTION INCLUDES

- A. Testing, adjustment, and balancing of air systems.
- B. Measurement of final operating condition of HVAC systems.

1.2 REFERENCE STANDARDS

- A. AABC (NSTSB) - AABC National Standards for Total System Balance, 7th Edition; 2016.
- B. AABC MN-1 - AABC National Standards for Total System Balance; Associated Air Balance Council; 2002.
- C. ASHRAE Std 111 - Measurement, Testing, Adjusting, and Balancing of Building HVAC Systems; 2008.
- D. NEBB (TAB) - Procedural Standards for Testing Adjusting Balancing of Environmental Systems; 2005, Seventh Edition.

1.3 SUBMITTALS

- A. See Division 1 Section - Administrative Requirements, for submittal procedures.
- B. Installer Qualifications: Submit name of adjusting and balancing agency and TAB supervisor for approval within 30 days after award of Contract.
- C. Final Report: Indicate deficiencies in systems that would prevent proper testing, adjusting, and balancing of systems and equipment to achieve specified performance.
 - 1. Submit to the the Commissioning Authority within two weeks after completion of testing, adjusting, and balancing.
 - 2. Revise TAB plan to reflect actual procedures and submit as part of final report.
 - 3. Provide reports in soft cover, letter size, 3-ring binder manuals, complete with index page and indexing tabs, with cover identification at front and side. Include set of reduced drawings with air outlets and equipment identified to correspond with data sheets, and indicating thermostat locations.
 - 4. Include actual instrument list, with manufacturer name, serial number, and date of calibration.
 - 5. Form of Test Reports: Where the TAB standard being followed recommends a report format use that; otherwise, follow ASHRAE Std 111.
 - 6. Units of Measure: Report data in I-P (inch-pound) units only.
 - 7. Include the following on the title page of each report:
 - a. Name of Testing, Adjusting, and Balancing Agency.
 - b. Address of Testing, Adjusting, and Balancing Agency.
 - c. Telephone number of Testing, Adjusting, and Balancing Agency.
 - d. Project name.
 - e. Project location.
 - f. Report date.
- D. Project Record Documents: Record actual locations of flow measuring stations and balancing valves and rough setting.

PART 2 PRODUCTS - NOT USED

PART 3 EXECUTION

3.1 GENERAL REQUIREMENTS

- A. Perform total system balance in accordance with one of the following:
 - 1. AABC (NSTSB), AABC National Standards for Total System Balance.
 - 2. ASHRAE Std 111, Practices for Measurement, Testing, Adjusting and Balancing of Building Heating, Ventilation, Air-Conditioning, and Refrigeration Systems.
 - 3. NEBB Procedural Standards for Testing Adjusting Balancing of Environmental Systems.

- B. Begin work after completion of systems to be tested, adjusted, or balanced and complete work prior to Substantial Completion of the project.
- C. Where HVAC systems and/or components interface with life safety systems, including fire and smoke detection, alarm, and control, coordinate scheduling and testing and inspection procedures with the authorities having jurisdiction.
- D. TAB Agency Qualifications:
 - 1. Company specializing in the testing, adjusting, and balancing of systems specified in this section.
 - 2. Having minimum of three years documented experience.
 - 3. Certified by one of the following:
 - a. AABC, Associated Air Balance Council: www.aabc.com/#sle; upon completion submit AABC National Performance Guaranty.
 - b. NEBB, National Environmental Balancing Bureau: www.nebb.org/#sle.
- E. TAB Supervisor Qualifications: Professional Engineer licensed in Oklahoma.

3.2 EXAMINATION

- A. Verify that systems are complete and operable before commencing work. Ensure the following conditions:
 - 1. Systems are started and operating in a safe and normal condition.
 - 2. Temperature control systems are installed complete and operable.
 - 3. Proper thermal overload protection is in place for electrical equipment.
 - 4. Final filters are clean and in place. If required, install temporary media in addition to final filters.
 - 5. Duct systems are clean of debris.
 - 6. Fans are rotating correctly.
 - 7. Fire and volume dampers are in place and open.
 - 8. Air coil fins are cleaned and combed.
 - 9. Access doors are closed and duct end caps are in place.
 - 10. Air outlets are installed and connected.
 - 11. Duct system leakage is minimized.
- B. Submit field reports. Report defects and deficiencies that will or could prevent proper system balance.
- C. Beginning of work means acceptance of existing conditions.

3.3 PREPARATION

- A. Hold a pre-balancing meeting at least one week prior to starting TAB work.
 - 1. Require attendance by all installers whose work will be tested, adjusted, or balanced.
- B. Provide instruments required for testing, adjusting, and balancing operations. Make instruments available to Architect to facilitate spot checks during testing.
- C. Provide additional balancing devices as required.

3.4 ADJUSTMENT TOLERANCES

- A. Air Handling Systems: Adjust to within plus or minus 10 percent of design for supply systems and plus or minus 10 percent of design for return and exhaust systems.
- B. Air Outlets and Inlets: Adjust total to within plus 10 percent and minus 10 percent of design to space. Adjust outlets and inlets in space to within plus or minus 10 percent of design.

3.5 RECORDING AND ADJUSTING

- A. Field Logs: Maintain written logs including:
 - 1. Running log of events and issues.
 - 2. Discrepancies, deficient or uncompleted work by others.
 - 3. Contract interpretation requests.
 - 4. Lists of completed tests.
- B. Ensure recorded data represents actual measured or observed conditions.

- C. Permanently mark settings of valves, dampers, and other adjustment devices allowing settings to be restored. Set and lock memory stops.
- D. After adjustment, take measurements to verify balance has not been disrupted or that such disruption has been rectified.
- E. Leave systems in proper working order, replacing belt guards, closing access doors, closing doors to electrical switch boxes, and restoring thermostats to specified settings.

3.6 AIR SYSTEM PROCEDURE

- A. Adjust air handling and distribution systems to provide required or design supply, return, and exhaust air quantities at site altitude.
- B. Make air quantity measurements in ducts by Pitot tube traverse of entire cross sectional area of duct.
- C. Measure air quantities at air inlets and outlets.
- D. Adjust distribution system to obtain uniform space temperatures free from objectionable drafts and noise.
- E. Use volume control devices to regulate air quantities only to extent that adjustments do not create objectionable air motion or sound levels. Effect volume control by duct internal devices such as dampers and splitters.
- F. Vary total system air quantities by adjustment of fan speeds. Provide drive changes required. Vary branch air quantities by damper regulation.
- G. Provide system schematic with required and actual air quantities recorded at each outlet or inlet.
- H. Measure static air pressure conditions on air supply units, including filter and coil pressure drops, and total pressure across the fan. Make allowances for 50 percent loading of filters.
- I. Adjust outside air automatic dampers, outside air, return air, and exhaust dampers for design conditions.
- J. Measure temperature conditions across outside air, return air, and exhaust dampers to check leakage.
- K. Where modulating dampers are provided, take measurements and balance at extreme conditions.

3.7 SCOPE

- A. Test, adjust, and balance the following:
 - 1. Forced Air Furnaces.
 - 2. Packaged Terminal Air Conditioning Units.
 - 3. Packaged vertical heat pumps
 - 4. Air Handling Units.
 - 5. Fans.
 - 6. Air Inlets and Outlets.
 - 7. Energy Recovery Ventilators

3.8 MINIMUM DATA TO BE REPORTED

- A. Electric Motors:
 - 1. Manufacturer.
 - 2. Model/Frame.
 - 3. HP/BHP.
 - 4. Phase, voltage, amperage; nameplate, actual, no load.
 - 5. RPM.
 - 6. Service factor.
 - 7. Starter size, rating, heater elements.
 - 8. Sheave Make/Size/Bore.
- B. V-Belt Drives:
 - 1. Identification/location.
 - 2. Required driven RPM.
 - 3. Driven sheave, diameter and RPM.
 - 4. Belt, size and quantity.

5. Motor sheave diameter and RPM.
 6. Center to center distance, maximum, minimum, and actual.
- C. Combustion Equipment:
1. Boiler manufacturer.
 2. Model number.
 3. Serial number.
- D. Air Cooled Condensers:
1. Location.
 2. Manufacturer.
 3. Model number.
- E. Electric Duct Heaters:
1. Manufacturer.
 2. Identification/number.
 3. Location.
 4. Design kW.
 5. Number of stages.
 6. Phase, voltage, amperage.
 7. Test voltage (each phase).
 8. Test amperage (each phase).
 9. Air flow, specified and actual.
 10. Temperature rise, specified and actual.
- F. Air Moving Equipment:
1. Location.
 2. Manufacturer.
 3. Model number.
 4. Air flow, specified and actual.
 5. Total static pressure (total external), specified and actual.
- G. Exhaust Fans:
1. Location.
 2. Manufacturer.
 3. Model number.
 4. Air flow, specified and actual.
 5. Total static pressure (total external), specified and actual.
- H. Air Distribution Tests:
1. Room number/location.
 2. Terminal type.
 3. Design air flow.
 4. Test (final) air flow.
 5. Percent of design air flow.

END OF SECTION 230593

SECTION 230713
DUCT INSULATION

PART 1 GENERAL

1.1 SECTION INCLUDES

- A. Duct insulation.
- B. Duct liner.

1.2 REFERENCE STANDARDS

- A. ASTM C534/C534M - Standard Specification for Preformed Flexible Elastomeric Cellular Thermal Insulation in Sheet and Tubular Form; 2014.
- B. ASTM C916 - Standard Specification for Adhesives for Duct Thermal Insulation; 2014.
- C. ASTM E84 - Standard Test Method for Surface Burning Characteristics of Building Materials; 2015a.
- D. ASTM E96/E96M - Standard Test Methods for Water Vapor Transmission of Materials; 2014.
- E. NFPA 255 - Standard Method of Test of Surface Burning Characteristics of Building Materials; National Fire Protection Association; 2006.
- F. SMACNA (DCS) - HVAC Duct Construction Standards Metal and Flexible; 2005.
- G. UL 723 - Standard for Test for Surface Burning Characteristics of Building Materials; Current Edition, Including All Revisions.

1.3 SUBMITTALS

- A. See Division 1 Section - Administrative Requirements, for submittal procedures.
- B. Product Data: Provide product description, thermal characteristics, list of materials and thickness for each service, and locations.
- C. Manufacturer's Instructions: Indicate installation procedures necessary to ensure acceptable workmanship and that installation standards will be achieved.

1.4 QUALITY ASSURANCE

- A. Manufacturer Qualifications: Company specializing in manufacturing products of the type specified in this section with not less than three years of documented experience.
- B. Applicator Qualifications: Company specializing in performing the type of work specified in this section, with minimum _____ years of experience and approved by manufacturer.

1.5 DELIVERY, STORAGE, AND HANDLING

- A. Accept materials on site in original factory packaging, labelled with manufacturer's identification, including product density and thickness.
- B. Protect insulation from weather and construction traffic, dirt, water, chemical, and mechanical damage, by storing in original wrapping.

1.6 FIELD CONDITIONS

- A. Maintain ambient temperatures and conditions required by manufacturers of adhesives, mastics, and insulation cements.
- B. Maintain temperature during and after installation for minimum period of 24 hours.

PART 2 PRODUCTS

2.1 REGULATORY REQUIREMENTS

- A. Surface Burning Characteristics: Flame spread index/Smoke developed index of 25/50, maximum, when tested in accordance with ASTM E84 or UL 723.

2.2 GLASS FIBER, FLEXIBLE

- A. Manufacturer:
 - 1. Knauf Insulation: www.knaufusa.com.

2. Johns Manville; _____: www.jm.com/#sle.
3. Owens Corning Corporation; _____: www.ocbuildingspec.com/#sle.
4. CertainTeed Corporation; : www.certainteed.com/#sle.

B. Vapor Barrier Jacket:

1. Kraft paper with glass fiber yarn and bonded to aluminized film.
2. Moisture Vapor Permeability: 0.02 perm inch, when tested in accordance with ASTM E96/E96M.
3. Secure with pressure sensitive tape.

C. Vapor Barrier Tape:

1. Kraft paper reinforced with glass fiber yarn and bonded to aluminized film, with pressure sensitive rubber based adhesive.

2.3 DUCT LINER

A. Manufacturers:

1. Knauf Insulation: www.knaufusa.com.
2. Johns Manville; _____: www.jm.com/#sle.
3. Owens Corning Corp: www.owenscorning.com.
4. CertainTeed Corporation; : www.certainteed.com/#sle.

B. Elastomeric Foam Insulation: Preformed flexible elastomeric cellular rubber insulation complying with ASTM C534/C534M Grade 1, in sheet form.

1. Minimum Service Temperature: Minus 40 degrees F.
2. Maximum Service Temperature: 180 degrees F.
3. Connection: Waterproof vapor barrier adhesive.

C. Elastomeric Foam Adhesive: Air dried, contact adhesive, compatible with insulation. Comply with ASTM C916.

D. Liner Fasteners: Galvanized steel, self-adhesive pad, impact applied, or welded with integral or press-on head.

PART 3 EXECUTION

3.1 EXAMINATION

- A. Test ductwork for design pressure prior to applying insulation materials.
- B. Verify that surfaces are clean, foreign material removed, and dry.

3.2 INSTALLATION

A. Install in accordance with manufacturer's instructions.

B. Insulated ducts:

1. Provide insulation with vapor barrier jackets.
2. Finish with tape and vapor barrier jacket.
3. Continue insulation through walls, sleeves, hangers, and other duct penetrations.
4. Insulate entire system, including fittings, joints, flanges, fire dampers, flexible connections, and expansion joints.

C. External Duct Insulation Application:

1. Secure insulation with vapor barrier with wires and seal jacket joints with vapor barrier adhesive or tape to match jacket.
2. Secure insulation without vapor barrier with staples, tape, or wires.
3. Install without sag on underside of duct. Use adhesive or mechanical fasteners where necessary to prevent sagging. Lift duct off trapeze hangers and insert spacers.
4. Seal vapor barrier penetrations by mechanical fasteners with vapor barrier adhesive.
5. Stop and point insulation around access doors and damper operators to allow operation without disturbing wrapping.

D. Duct and Plenum Liner Application:

1. Adhere insulation with adhesive for 90 percent coverage.

2. Secure insulation with mechanical liner fasteners. Refer to SMACNA (DCS) for spacing.
3. Seal and smooth joints. Seal and coat transverse joints.
4. Seal liner surface penetrations with adhesive.
5. Duct dimensions indicated are net inside dimensions required for air-flow. Increase duct size to allow for insulation thickness.

3.3 SCHEDULES

- A. Dwelling unit ductwork located outside of conditioned spaces: Flexible glass fiber duct insulation, 3" thick. Minimum installed R-value shall be R-8. Ductwork in attics shall additionally have full depth attic insulation installed above ductwork.
- B. All Outside Air Intake Ducts: Flexible glass fiber duct insulation, 1-1/2" thick.
- C. Clubhouse supply ducts from space heating and cooling equipment: Flexible glass fiber duct insulation, 1-1/2" thick.
- D. Transfer ducts between occupied spaces and mechanical rooms: Glass Fiber Duct Liner, 1/2" thick.
- E. Exhaust ducts within 15' of exterior penetration: Flexible glass fiber duct insulation, 1-1/2" thick.
- F. Clubhouse supply and return ducts within 5' of air handling equipment: Glass Fiber Duct Liner, 1/2" thick.

END OF SECTION 230713

SECTION 230719
HVAC PIPING INSULATION

PART 1 GENERAL

1.1 SECTION INCLUDES

- A. Piping insulation.
- B. Flexible removable and reusable blanket insulation.
- C. Jackets and accessories.

1.2 REFERENCE STANDARDS

- A. ASTM C534/C534M - Standard Specification for Preformed Flexible Elastomeric Cellular Thermal Insulation in Sheet and Tubular Form; 2014.
- B. ASTM E84 - Standard Test Method for Surface Burning Characteristics of Building Materials; 2015a.
- C. ASTM E96/E96M - Standard Test Methods for Water Vapor Transmission of Materials; 2014.
- D. NFPA 255 - Standard Method of Test of Surface Burning Characteristics of Building Materials; National Fire Protection Association; 2006.
- E. UL 723 - Standard for Test for Surface Burning Characteristics of Building Materials; Current Edition, Including All Revisions.

1.3 SUBMITTALS

- A. Product Data: Provide product description, thermal characteristics, list of materials and thickness for each service, and locations.

PART 2 PRODUCTS

2.1 REGULATORY REQUIREMENTS

- A. Surface Burning Characteristics: Flame spread index/Smoke developed index of 25/50, maximum, when tested in accordance with ASTM E84 or UL 723.

2.2 FLEXIBLE ELASTOMERIC CELLULAR INSULATION

- A. Manufacturers:
 - 1. Armacell LLC; AP Armaflex: www.armacell.us/#sle.
- B. Insulation: Preformed flexible elastomeric cellular rubber insulation complying with ASTM C534/C534M Grade 1; use molded tubular material wherever possible.
 - 1. Minimum Service Temperature: Minus 40 degrees F.
 - 2. Maximum Service Temperature: 180 degrees F.
 - 3. Connection: Waterproof vapor barrier adhesive.
- C. Elastomeric Foam Adhesive: Air dried, contact adhesive, compatible with insulation.

2.3 JACKETS

- A. PVC Plastic.
 - 1. Jacket: One piece molded type fitting covers and sheet material, off-white color.
 - a. Minimum Service Temperature: 0 degrees F.
 - b. Maximum Service Temperature: 150 degrees F.
 - c. Moisture Vapor Permeability: 0.002 perm inch, maximum, when tested in accordance with ASTM E96/E96M.
 - d. Thickness: 10 mil.
 - e. Connections: Brush on welding adhesive.

PART 3 EXECUTION

3.1 EXAMINATION

- A. Test piping for design pressure, liquid tightness, and continuity prior to applying insulation materials.
- B. Verify that surfaces are clean and dry, with foreign material removed.

3.2 INSTALLATION

- A. Install in accordance with manufacturer's instructions.
- B. Exposed Piping: Locate insulation and cover seams in least visible locations.
- C. Inserts and Shields:
 - 1. Application: Piping 1-1/2 inches diameter or larger.
 - 2. Shields: Galvanized steel between pipe hangers or pipe hanger rolls and inserts.
 - 3. Insert location: Between support shield and piping and under the finish jacket.
 - 4. Insert Configuration: Minimum 6 inches long, of same thickness and contour as adjoining insulation; may be factory fabricated.
 - 5. Insert Material: Hydrous calcium silicate insulation or other heavy density insulating material suitable for the planned temperature range.
- D. Continue insulation through walls, sleeves, pipe hangers, and other pipe penetrations. Finish at supports, protrusions, and interruptions. At fire separations, refer to "Firestopping" Section.
- E. Pipe Exposed in Mechanical Equipment Rooms or Finished Spaces (less than 10 feet above finished floor): Finish with canvas jacket sized for finish painting.
- F. Exterior Applications: Provide PVC jacket.

3.3 SCHEDULE

- A. Cooling Systems:
 - 1. Condensate Drains from Cooling Coils: 1/2" Flexible Elastomeric
 - 2. Refrigerant Suction: 1" Flexible Elastomeric
 - 3. Refrigerant Liquid/hot gas: Per system manufacturer's recommendations

END OF SECTION 230719

SECTION 232100
GENERAL REQUIREMENTS FOR HVAC PIPING

PART 1 - GENERAL

1.1 RELATED DOCUMENTS

- A. Drawings and general provisions of the Contract, including General and Supplementary Conditions and Division 01 Specification Sections, apply to this Section.

1.2 SUMMARY

- A. Section Includes:
 - 1. Sleeves.
 - 2. Sleeve-seal systems.
 - 3. Grout.
 - 4. Escutcheons.

PART 2 - PRODUCTS

2.1 SLEEVES

- A. Cast-Iron Wall Pipes: Cast or fabricated of cast or ductile iron and equivalent to ductile-iron pressure pipe, with plain ends and integral waterstop unless otherwise indicated.
- B. Galvanized-Steel Wall Pipes: ASTM A 53/A 53M, Schedule 40, with plain ends and welded steel collar; zinc coated.
- C. Galvanized-Steel-Pipe Sleeves: ASTM A 53/A 53M, Type E, Grade B, Schedule 40, zinc coated, with plain ends.
- D. PVC-Pipe Sleeves: ASTM D 1785, Schedule 40.
- E. Galvanized-Steel-Sheet Sleeves: 0.0239-inch minimum thickness; round tube closed with welded longitudinal joint.
- F. Molded-PE or -PP Sleeves: Removable, tapered-cup shaped, and smooth outer surface with nailing flange for attaching to wooden forms.
- G. Molded-PVC Sleeves: With nailing flange for attaching to wooden forms.

2.2 SLEEVE-SEAL SYSTEMS

- A. Description: Modular sealing-element unit, designed for field assembly, for filling annular space between piping and sleeve.
 - 1. Sealing Elements: EPDM-rubber interlocking links shaped to fit surface of pipe. Include type and number required for pipe material and size of pipe.
 - 2. Pressure Plates: Stainless steel.
 - 3. Connecting Bolts and Nuts: Carbon steel, with corrosion-resistant coating, of length required to secure pressure plates to sealing elements.

2.3 GROUT

- A. Standard: ASTM C 1107/C 1107M, Grade B, post-hardening and volume-adjusting, dry, hydraulic-cement grout.
- B. Characteristics: Nonshrink; recommended for interior and exterior applications.
- C. Design Mix: 5000-psi, 28-day compressive strength.
- D. Packaging: Premixed and factory packaged.

2.4 ESCUTCHEONS

- A. One-Piece, Stamped-Steel Type: With chrome-plated finish and spring-clip fasteners.
- B. Split-Plate, Stamped-Steel Type: With chrome-plated finish, concealed or exposed-rivet hinge, and spring-clip fasteners.

PART 3 - EXECUTION

3.1 SLEEVE INSTALLATION

- A. Install sleeves for piping passing through penetrations in floors, partitions, roofs, and walls.
- B. For sleeves that will have sleeve-seal system installed, select sleeves of size large enough to provide 1-inch annular clear space between piping and concrete slabs and walls.
 - 1. Sleeves are not required for core-drilled holes.
- C. Install sleeves in concrete floors, concrete roof slabs, and concrete walls as new slabs and walls are constructed.
 - 1. Permanent sleeves are not required for holes in slabs formed by molded-PE or -PP sleeves.
 - 2. Cut sleeves to length for mounting flush with both surfaces.
 - a. Exception: Extend sleeves installed in floors of mechanical equipment areas or other wet areas 2 inches above finished floor level.
 - 3. Using grout, seal the space outside of sleeves in slabs and walls without sleeve-seal system.
- D. Install sleeves for pipes passing through interior partitions.
 - 1. Cut sleeves to length for mounting flush with both surfaces.
 - 2. Install sleeves that are large enough to provide 1/4-inch annular clear space between sleeve and pipe or pipe insulation.
 - 3. Seal annular space between sleeve and piping or piping insulation; use joint sealants appropriate for size, depth, and location of joint. Comply with requirements for sealants specified in other sections.
- E. Fire-Barrier Penetrations: Maintain indicated fire rating of walls, partitions, ceilings, and floors at pipe penetrations. Seal pipe penetrations with firestop materials. Comply with requirements for firestopping specified in other sections.

3.2 SLEEVE-SEAL-SYSTEM INSTALLATION

- A. Install sleeve-seal systems in sleeves in exterior concrete walls and slabs-on-grade at service piping entries into building.
- B. Select type, size, and number of sealing elements required for piping material and size and for sleeve ID or hole size. Position piping in center of sleeve. Center piping in penetration, assemble sleeve-seal system components, and install in annular space between piping and sleeve. Tighten bolts against pressure plates that cause sealing elements to expand and make a watertight seal.

3.3 ESCUTCHEON INSTALLATION

- A. Install escutcheons for piping penetrations of walls, ceilings, and finished floors.
- B. Install escutcheons with ID to closely fit around pipe, tube, and insulation of piping and with OD that completely covers opening.
 - 1. Escutcheon Schedule:
 - a. Bare Piping in Unfinished Service Spaces: One-piece, stamped-steel type or split-plate, stamped-steel type with exposed-rivet hinge.
 - b. Bare Piping in Equipment Rooms: One-piece, stamped-steel type or split-plate, stamped-steel type with exposed-rivet hinge.

END OF SECTION 232100

SECTION 232300
REFRIGERANT PIPING

PART 1 GENERAL

1.1 SECTION INCLUDES

- A. Piping.
- B. Refrigerant.

1.2 RELATED REQUIREMENTS

- A. Section 083100 - Access Doors and Panels.
- B. Section 230719 - HVAC Piping Insulation.

1.3 REFERENCE STANDARDS

- A. ASHRAE Std 15 - Safety Standard for Refrigeration Systems; 2013.
- B. ASHRAE Std 34 - Designation and Safety Classification of Refrigerants; 2013.
- C. ASME B16.22 - Wrought Copper and Copper Alloy Solder-Joint Pressure Fittings; 2013.
- D. ASME B31.5 - Refrigeration Piping and Heat Transfer Components; 2013.
- E. ASTM B280 - Standard Specification for Seamless Copper Tube for Air Conditioning and Refrigeration Field Service; 2013.
- F. AWS A5.8M/A5.8 - Specification for Filler Metals for Brazing and Braze Welding; 2011-AMD 1.

1.4 SYSTEM DESCRIPTION

- A. Where more than one piping system material is specified ensure system components are compatible and joined to ensure the integrity of the system is not jeopardized. Provide necessary joining fittings. Ensure flanges, union, and couplings for servicing are consistently provided.
- B. Provide pipe hangers and supports in accordance with ASME B31.5 unless indicated otherwise.

1.5 DELIVERY, STORAGE, AND HANDLING

- A. Deliver and store piping and specialties in shipping containers with labeling in place.
- B. Protect piping and specialties from entry of contaminating material by leaving end caps and plugs in place until installation.
- C. Dehydrate and charge components such as piping and receivers, seal prior to shipment, until connected into system.

PART 2 PRODUCTS

2.1 PIPING

- A. Copper Tube: ASTM B280, H58 hard drawn or O60 soft annealed.
 - 1. Fittings: ASME B16.22 wrought copper.
 - 2. Joints: Braze, AWS A5.8M/A5.8 BCuP silver/phosphorus/copper alloy.
- B. Pipe Supports and Anchors:
 - 1. Conform to ASME B31.5.
 - 2. Hangers for Pipe Sizes 1/2 to 1-1/2 Inch: Malleable iron adjustable swivel, split ring.
 - 3. Hangers for Pipe Sizes 2 Inches and Over: Carbon steel, adjustable, clevis.
 - 4. Multiple or Trapeze Hangers: Steel channels with welded spacers and hanger rods.
 - 5. Floor Support: Cast iron adjustable pipe saddle, lock nut, nipple, floor flange, and concrete pier or steel support.
 - 6. Copper Pipe Support: Carbon steel ring, adjustable, copper plated.
 - 7. Hanger Rods: Mild steel threaded both ends, threaded one end, or continuous threaded.
 - 8. Inserts: Malleable iron case of galvanized steel shell and expander plug for threaded connection with lateral adjustment, top slot for reinforcing rods, lugs for attaching to forms; size inserts to suit threaded hanger rods.

2.2 REFRIGERANT

- A. Refrigerant: R-134a, tetrafluoroethane as defined in ASHRAE Std 34.

PART 3 EXECUTION

3.1 PREPARATION

- A. Ream pipe and tube ends. Remove burrs. Bevel plain end ferrous pipe.
- B. Remove scale and dirt on inside and outside before assembly.
- C. Prepare piping connections to equipment with flanges or unions.

3.2 INSTALLATION

- A. Install refrigerant piping and accessories in accordance with split system manufacturer's recommendations.
- B. Install refrigeration specialties in accordance with manufacturer's instructions.
- C. Route piping in orderly manner, with plumbing parallel to building structure, and maintain gradient.
- D. Install piping to conserve building space and avoid interference with use of space.
- E. Group piping whenever practical at common elevations and locations. Slope piping per manufacturer's recommendations.
- F. Install piping to allow for expansion and contraction without stressing pipe, joints, or connected equipment.
- G. Pipe Hangers and Supports:
 - 1. Install in accordance with ASME B31.5.
 - 2. Support horizontal piping as indicated.
 - 3. Install hangers to provide minimum 1/2 inch space between finished covering and adjacent work.
 - 4. Place hangers within 12 inches of each horizontal elbow.
 - 5. Support vertical piping at every other floor. Support riser piping independently of connected horizontal piping.
 - 6. Where several pipes can be installed in parallel and at same elevation, provide multiple or trapeze hangers.
 - 7. Provide copper plated hangers and supports for copper piping.
- H. Arrange piping to return oil to compressor. Provide traps and loops in piping, and provide double risers as required. Slope horizontal piping 0.40 percent in direction of flow.
- I. Provide clearance for installation of insulation and access to valves and fittings.
- J. Provide access to concealed valves and fittings. Coordinate size and location of access doors with Section 083100.
- K. Flood piping system with nitrogen when brazing.
- L. Where pipe support members are welded to structural building frame, brush clean, and apply one coat of zinc rich primer to welding.
- M. Follow ASHRAE Std 15 procedures for charging and purging of systems and for disposal of refrigerant.
- N. Fully charge completed system with refrigerant after testing.

3.3 FIELD QUALITY CONTROL

- A. See Section 014000 - Quality Requirements, for additional requirements.
- B. Test refrigeration system in accordance with ASME B31.5, and in accordance with VRFZ system manufacturer's recommendations.

3.4 SCHEDULES

- A. Hanger Spacing for Copper Tubing.
 - 1. 1/2 inch, 5/8 inch, and 7/8 inch OD: Maximum span, 5 feet; minimum rod size, 1/4 inch.
 - 2. 1-1/8 inch OD: Maximum span, 6 feet; minimum rod size, 1/4 inch.

3. 1-3/8 inch OD: Maximum span, 7 feet; minimum rod size, 3/8 inch.
4. 1-5/8 inch OD: Maximum span, 8 feet; minimum rod size, 3/8 inch.

END OF SECTION 232300

SECTION 233100
HVAC DUCTS AND CASINGS

PART 1 GENERAL

1.1 SECTION INCLUDES

- A. Metal ductwork.
- B. Duct cleaning.

1.2 RELATED REQUIREMENTS

- A. Section 230713 - Duct Insulation: External insulation and duct liner.
- B. Section 233300 - Air Duct Accessories.
- C. Section 230593 - Testing, Adjusting, and Balancing for HVAC.

1.3 REFERENCE STANDARDS

- A. ASHRAE (FUND) - ASHRAE Handbook - Fundamentals; 2013.
- B. ASTM A653/A653M - Standard Specification for Steel Sheet, Zinc-Coated (Galvanized) or Zinc-Iron Alloy-Coated (Galvannealed) by the Hot-Dip Process; 2015.
- C. ASTM A666 - Standard Specification for Annealed or Cold-Worked Austenitic Stainless Steel Sheet, Strip, Plate, and Flat Bar; 2015.
- D. ASTM B209 - Standard Specification for Aluminum and Aluminum-Alloy Sheet and Plate; 2014.
- E. ASTM B209M - Standard Specification for Aluminum and Aluminum-Alloy Sheet and Plate [Metric]; 2014.
- F. ASTM E84 - Standard Test Method for Surface Burning Characteristics of Building Materials; 2015a.
- G. NFPA 90A - Standard for the Installation of Air-Conditioning and Ventilating Systems; 2015.
- H. SMACNA (DCS) - HVAC Duct Construction Standards Metal and Flexible; 2005.

1.4 PERFORMANCE REQUIREMENTS

- A. No variation of duct configuration or sizes permitted except by written permission. Size round ducts installed in place of rectangular ducts in accordance with ASHRAE table of equivalent rectangular and round ducts.

1.5 SUBMITTALS

- A. See Division 1 Section - Administrative Requirements, for submittal procedures.
- B. Project Record Documents: Record actual locations of ducts and duct fittings. Record changes in fitting location and type. Show additional fittings used.

1.6 FIELD CONDITIONS

- A. Do not install duct sealants when temperatures are less than those recommended by sealant manufacturers.
- B. Maintain temperatures within acceptable range during and after installation of duct sealants.

PART 2 PRODUCTS

2.1 DUCT ASSEMBLIES

- A. Regulatory Requirements: Construct ductwork to comply with NFPA 90A standards.

2.2 MATERIALS

- A. Galvanized Steel for Ducts: Hot-dipped galvanized steel sheet, ASTM A653/A653M FS Type B, with G60/Z180 coating.
- B. Aluminum for Ducts: ASTM B209 (ASTM B209M); aluminum sheet, alloy 3003-H14. Aluminum Connectors and Bar Stock: Alloy 6061-T651 or of equivalent strength.
- C. Stainless Steel for Ducts: ASTM A666, Type 304.

- D. Joint Sealers and Sealants: Non-hardening, water resistant, mildew and mold resistant.
 - 1. Type: Heavy mastic or liquid used alone or with tape, suitable for joint configuration and compatible with substrates, and recommended by manufacturer for pressure class of ducts.
 - 2. Surface Burning Characteristics: Flame spread index of zero and smoke developed index of zero, when tested in accordance with ASTM E84.
- E. Insulated Flexible Ducts:
 - 1. Two ply vinyl film supported by helically wound spring steel wire; fiberglass insulation; polyethylene vapor barrier film.
 - a. Pressure Rating: 10 inches WG positive and 1.0 inches WG negative.
 - b. Maximum Velocity: 4000 fpm.
 - c. Temperature Range: -10 degrees F to 160 degrees F.
- F. Joint Sealers and Sealants: Non-hardening, water resistant, mildew and mold resistant.

2.3 DUCTWORK FABRICATION

- A. Fabricate and support in accordance with SMACNA (DCS) and as indicated.
- B. No variation of duct configuration or size permitted except by written permission.
- C. Provide duct material, gages, reinforcing, and sealing for operating pressures indicated.
- D. Construct T's, bends, and elbows with radius of not less than 1-1/2 times width of duct on centerline. Where not possible and where rectangular elbows must be used, provide air foil turning vanes of perforated metal with glass fiber insulation.
- E. Provide turning vanes of perforated metal with glass fiber insulation when acoustical lining is indicated.
- F. Provide air foil turning vanes when rectangular elbows must be used.
- G. Increase duct sizes gradually, not exceeding 15 degrees divergence wherever possible; maximum 30 degrees divergence upstream of equipment and 45 degrees convergence downstream.
- H. Fabricate continuously welded round and oval duct fittings in accordance with SMACNA (DCS).
- I. Provide standard 45 degree lateral wye takeoffs unless otherwise indicated where 90 degree conical tee connections may be used.
- J. Where ducts are connected to exterior wall louvers and duct outlet is smaller than louver frame, provide blank-out panels sealing louver area around duct. Use same material as duct, painted black on exterior side; seal to louver frame and duct.

2.4 MANUFACTURED DUCTWORK AND FITTINGS

- A. Manufacture in accordance with SMACNA HVAC Duct Construction Standards - Metal and Flexible, and as indicated. Provide duct material, gages, reinforcing, and sealing for operating pressures indicated.
- B. Transverse Duct Connection System: SMACNA "E" rated rigidly class connection, interlocking angle and duct edge connection system with sealant, gasket, cleats, and corner clips in accordance with SMACNA (DCS).

PART 3 EXECUTION

3.1 INSTALLATION

- A. Install, support, and seal ducts in accordance with SMACNA (DCS).
- B. Install in accordance with manufacturer's instructions.
- C. During construction provide temporary closures of metal or taped polyethylene on open ductwork to prevent construction dust from entering ductwork system.
- D. Duct sizes indicated are inside clear dimensions. For lined ducts, maintain sizes inside lining.
- E. Install and seal metal and flexible ducts in accordance with SMACNA HVAC Duct Construction Standards - Metal and Flexible.
- F. Provide openings in ductwork where required to accommodate thermometers and controllers. Provide pilot tube openings where required for testing of systems, complete with metal can with spring device or

screw to ensure against air leakage. Where openings are provided in insulated ductwork, install insulation material inside a metal ring.

- G. Locate ducts with sufficient space around equipment to allow normal operating and maintenance activities.
- H. Use crimp joints with or without bead for joining round duct sizes 8 inch and smaller with crimp in direction of air flow.
- I. Use double nuts and lock washers on threaded rod supports.
- J. Connect flexible ducts to metal ducts with draw bands plus sheet metal screws and adhesive. Use a maximum of 5' of flexible duct, at final connection to diffusers only, free of kinks. Do not install above inaccessible ceilings. Do not use flexible ductwork in exposed areas.
- K. During construction provide temporary closures of metal or taped polyethylene on open ductwork to prevent construction dust from entering ductwork system.
- L. At exterior wall louvers, seal duct to louver frame and install blank-out panels.
- M. Seal all ductwork in accordance with the International Mechanical Code and International Residential Code, as applicable.
- N. Test all ductwork in accordance with the International Energy Conservation Code. If initial testing does not achieve acceptable leakage rate, repair and retest until leakage is below acceptable leakage rate.

3.2 CLEANING

- A. Clean duct system and force air at high velocity through duct to remove accumulated dust. To obtain sufficient air, clean half the system at a time. Protect equipment that could be harmed by excessive dirt with temporary filters, or bypass during cleaning.

3.3 SCHEDULES

- A. Ductwork Material:
 - 1. Low Pressure Supply (Heating Systems): Steel.
 - 2. Low Pressure Supply (System with Cooling Coils): Steel.
 - 3. Return and Relief: Steel.
 - 4. General Exhaust: Steel.
 - 5. Outside Air Intake: Steel.
- B. Ductwork Pressure Class:
 - 1. Supply (System with Cooling Coils): 1 inch.
 - 2. Return and Relief: 1 inch.
 - 3. General Exhaust: 1/2 inch.
- C. Round ductwork shall be double wall spiral where exposed. Concealed round ductwork may be spiral, double or single wall, or fabricated.

END OF SECTION 233100

SECTION 233300
AIR DUCT ACCESSORIES

PART 1 GENERAL

1.1 SECTION INCLUDES

- A. Air turning devices/extractors.
- B. Backdraft dampers.
- C. Combination fire and smoke dampers.
- D. Duct access doors.
- E. Duct test holes.
- F. Fire dampers.
- G. Flexible duct connectors.
- H. Smoke dampers.
- I. Volume control dampers.

1.2 RELATED REQUIREMENTS

- A. Section 233100 - HVAC Ducts and Casings.

1.3 REFERENCE STANDARDS

- A. NFPA 90A - Standard for the Installation of Air-Conditioning and Ventilating Systems; 2015.
- B. NFPA 92 - Standard for Smoke Control Systems; 2015.
- C. NFPA 96 - Standard for Ventilation Control and Fire Protection of Commercial Cooking Operations; 2014.
- D. SMACNA (DCS) - HVAC Duct Construction Standards Metal and Flexible; 2005.
- E. UL 33 - Safety Heat Responsive Links for Fire-Protection Service; Current Edition, Including All Revisions.
- F. UL 555 - Standard for Fire Dampers; Current Edition, Including All Revisions.
- G. UL 555S - Standard for Smoke Dampers; Current Edition, Including All Revisions.

1.4 SUBMITTALS

- A. See Division 1 Section - Administrative Requirements, for submittal procedures.
- B. Product Data: Provide for shop fabricated assemblies including volume control dampers. Include electrical characteristics and connection requirements.
- C. Shop Drawings: Indicate for shop fabricated assemblies including volume control dampers.
- D. Manufacturer's Installation Instructions: Provide instructions for fire dampers.
- E. Project Record Drawings: Record actual locations of access doors and test holes.

1.5 DELIVERY, STORAGE, AND HANDLING

- A. Protect dampers from damage to operating linkages and blades.

PART 2 PRODUCTS

2.1 AIR TURNING DEVICES/EXTRACTORS

- A. Multi-blade device with blades aligned in short dimension; steel construction; with individually adjustable blades, mounting straps.

2.2 BACKDRAFT DAMPERS

- A. Gravity Backdraft Dampers, Size 18 by 18 inches or Smaller, Furnished with Air Moving Equipment: Air moving equipment manufacturer's standard construction.

2.3 COMBINATION FIRE AND SMOKE DAMPERS

- A. Fabricate in accordance with NFPA 90A, UL 555, UL 555S, and as indicated.
- B. Provide factory sleeve and collar for each damper.
- C. Multiple Blade Dampers: Fabricate with 16 gage galvanized steel frame and blades, oil-impregnated bronze or stainless steel sleeve bearings and plated steel axles, stainless steel jamb seals, 1/8 x 1/2 inch plated steel concealed linkage, stainless steel closure spring, blade stops, and lock, and 1/2 inch actuator shaft.
- D. Operators: UL listed and labelled spring return electric type suitable for 120 volts, single phase, 60 Hz. Provide end switches to indicate damper position. Locate damper operator on interior of duct and link to damper operating shaft.

2.4 DUCT ACCESS DOORS

- A. Fabrication: Rigid and close-fitting of galvanized steel with sealing gaskets and quick fastening locking devices. For insulated ducts, install minimum 1 inch thick insulation with sheet metal cover.
 - 1. Less Than 12 inches Square: Secure with sash locks.
 - 2. Up to 18 inches Square: Provide two hinges and two sash locks.
 - 3. Up to 24 x 48 inches: Three hinges and two compression latches with outside and inside handles.
 - 4. Larger Sizes: Provide an additional hinge.

2.5 DUCT TEST HOLES

- A. Temporary Test Holes: Cut or drill in ducts as required. Cap with neat patches, neoprene plugs, threaded plugs, or threaded or twist-on metal caps.
- B. Permanent Test Holes: Factory fabricated, air tight flanged fittings with screw cap. Provide extended neck fittings to clear insulation.

2.6 FIRE DAMPERS

- A. Fabricate in accordance with NFPA 90A and UL 555, and as indicated.
- B. Ceiling Dampers: Galvanized steel, 22 gage frame and 16 gage flap, two layers 0.125 inch ceramic fiber on top side and one layer on bottom side for round flaps, with locking clip.
- C. Horizontal Dampers: Galvanized steel, 22 gage frame, stainless steel closure spring, and lightweight, heat retardant non-asbestos fabric blanket.
- D. Curtain Type Dampers: Galvanized steel with interlocking blades. Provide stainless steel closure springs and latches for horizontal installations. Configure with blades out of air stream except for 1.0 inch pressure class ducts up to 12 inches in height.
- E. Multiple Blade Dampers: 16 gage galvanized steel frame and blades, oil-impregnated bronze or stainless steel sleeve bearings and plated steel axles, 1/8 x 1/2 inch plated steel concealed linkage, stainless steel closure spring, blade stops, and lock.
- F. Fusible Links: UL 33, separate at 160 degrees F with adjustable link straps for combination fire/balancing dampers.

2.7 FLEXIBLE DUCT CONNECTORS

- A. Fabricate in accordance with SMACNA (DCS) and as indicated.
- B. Flexible Duct Connections: Fabric crimped into metal edging strip.
 - 1. Fabric: UL listed fire-retardant neoprene coated woven glass fiber fabric to NFPA 90A, minimum density 30 oz per sq yd.
 - a. Net Fabric Width: Approximately 2 inches wide.
 - 2. Metal: 3 inches wide, 24 gage, 0.0239 inch thick galvanized steel.
- C. Leaded Vinyl Sheet: Minimum 0.55 inch thick, 0.87 lbs per sq ft, 10 dB attenuation in 10 to 10,000 Hz range.

2.8 SMOKE DAMPERS

- A. Fabricate in accordance with NFPA 90A and UL 555S, and as indicated.

- B. Dampers: UL Class 1 multiple blade type fire damper, normally closed automatically operated by 120 VAC electric actuator.

2.9 VOLUME CONTROL DAMPERS

- A. Fabricate in accordance with SMACNA (DCS) and as indicated.
- B. Splitter Dampers:
 - 1. Material: Same gage as duct to 24 inches size in either direction, and two gages heavier for sizes over 24 inches.
 - 2. Blade: Fabricate of single thickness sheet metal to streamline shape, secured with continuous hinge or rod.
 - 3. Operator: Minimum 1/4 inch diameter rod in self aligning, universal joint action, flanged bushing with set screw .
- C. Single Blade Dampers: Fabricate for duct sizes up to 6 x 30 inch.
- D. Multi-Blade Damper: Fabricate of opposed blade pattern with maximum blade sizes 8 x 72 inch. Assemble center and edge crimped blades in prime coated or galvanized channel frame with suitable hardware.
- E. End Bearings: Except in round ducts 12 inches and smaller, provide end bearings. On multiple blade dampers, provide oil-impregnated nylon, thermoplastic elastomer, or sintered bronze bearings.
- F. Quadrants:
 - 1. Provide locking, indicating quadrant regulators on single and multi-blade dampers.
 - 2. On insulated ducts mount quadrant regulators on stand-off mounting brackets, bases, or adapters.

PART 3 EXECUTION

3.1 INSTALLATION

- A. Install accessories in accordance with manufacturer's instructions, NFPA 90A, and follow SMACNA (DCS). Refer to Section 233100 for duct construction and pressure class.
- B. Provide backdraft dampers on exhaust fans or exhaust ducts nearest to outside and where indicated.
- C. Provide duct access doors for inspection and cleaning before and after filters, coils, fans, automatic dampers, at fire dampers, combination fire and smoke dampers, and elsewhere as indicated. Provide for cleaning kitchen exhaust ducts in accordance with NFPA 96. Provide minimum 8 by 8 inch size for hand access, size for shoulder access, and as indicated. Provide 4 by 4 inch for balancing dampers only. Review locations prior to fabrication.
- D. Provide duct access doors for inspection and cleaning before and after filters, coils, fans, automatic dampers, at fire dampers, combination fire and smoke dampers, and elsewhere as indicated. Provide minimum 8 x 8 inch size for hand access, 18 x 18 inch size for shoulder access, and as indicated. Provide 4 x 4 inch for balancing dampers only. Review locations prior to fabrication.
- E. Provide duct test holes where indicated and required for testing and balancing purposes.
- F. Provide fire dampers, combination fire and smoke dampers, and smoke dampers at locations indicated, where ducts and outlets pass through fire rated components, and where required by Authorities Having Jurisdiction. Install with required perimeter mounting angles, sleeves, breakaway duct connections, corrosion resistant springs, bearings, bushings and hinges.
- G. Install smoke dampers and combination smoke and fire dampers in accordance with NFPA 92.
- H. Install smoke damper motors in locations to allow service/replacement without removal of permanent building components.
- I. Demonstrate re-setting of fire dampers to Owner's representative.
- J. At fans and motorized equipment associated with ducts, provide flexible duct connections immediately adjacent to the equipment.
- K. Provide balancing dampers at points on supply, return, and exhaust systems where branches are taken from larger ducts as required for air balancing. Install minimum 2 duct widths from duct take-off.

- L. Provide balancing dampers on duct take-off to diffusers, grilles, and registers, regardless of whether dampers are specified as part of the diffuser, grille, or register assembly. Omit dampers only where noted on drawings.
- M. Where dampers or other accessories that require adjustment or maintenance are located above hard ceilings, provide access panel in ceiling. Coordinate with G.C.

END OF SECTION 233300

SECTION 233700
AIR OUTLETS AND INLETS

PART 1 GENERAL

1.1 SECTION INCLUDES

- A. Diffusers:
- B. Registers/grilles:
- C. Roof hoods.

1.2 REFERENCE STANDARDS

- A. ASHRAE Std 70 - Method of Testing the Performance of Air Outlets and Inlets; 2006 (R2011).
- B. SMACNA (DCS) - HVAC Duct Construction Standards Metal and Flexible; 2005.

1.3 SUBMITTALS

- A. See Division 1 Section - Administrative Requirements, for submittal procedures.
- B. Product Data: Provide data for equipment required for this project. Review outlets and inlets as to size, finish, and type of mounting prior to submission. Submit schedule of outlets and inlets showing type, size, location, application, and noise level.

1.4 QUALITY ASSURANCE

- A. Test and rate air outlet and inlet performance in accordance with ASHRAE Std 70.

PART 2 PRODUCTS

2.1 MANUFACTURERS

- A. Hart & Cooley, Inc: www.hartandcooley.com.
- B. Krueger-HVAC; _____: www.krueger-hvac.com/#sle.
- C. Price Industries; _____: www.price-hvac.com/#sle.
- D. Titus, a brand of Air Distribution Technologies; _____: www.titus-hvac.com/#sle.

2.2 DIFFUSERS, REGISTERS, AND GRILLES

- A. Type and performance are scheduled on the drawings.
- B. Coordinate finish of all devices with Architect.

2.3 ROOF HOODS

- A. Fabricate air inlet or exhaust hoods in accordance with SMACNA (DCS).
- B. Fabricate of galvanized steel, minimum 16 gage, 0.0598 inch base and 20 gage, 0.0359 inch hood, or aluminum, minimum 16 gage, 0.0598 inch base and 18 gage, 0.0598 inch hood; suitably reinforced; with removable hood; birdscreen with 1/2 inch square mesh for exhaust and 3/4 inch for intake, and factory prime coat finish.
- C. Mount unit on minimum 12 inch high curb base with insulation between duct and curb.
- D. Make hood outlet area minimum of twice throat area.

PART 3 EXECUTION

3.1 INSTALLATION

- A. Install in accordance with manufacturer's instructions.
- B. Check location of outlets and inlets and make necessary adjustments in position to comply with architectural features, symmetry, and lighting arrangement.
- C. Install diffusers to ductwork with air tight connection.
- D. Provide balancing dampers on duct take-off to diffusers, and grilles and registers, despite whether dampers are specified as part of the diffuser, or grille and register assembly. Omit dampers where drawings specifically indicate devices are to be provided without dampers.

E. Paint ductwork visible behind air outlets and inlets matte black. Coordinate with G.C.

END OF SECTION 233700

SECTION 234000
HVAC AIR CLEANING DEVICES

PART 1 GENERAL

1.1 SECTION INCLUDES

- A. Disposable, extended area panel filters.
- B. Disposable panel filters.

1.2 REFERENCE STANDARDS

- A. ASHRAE Std 52.2 - Method of Testing General Ventilation Air-Cleaning Devices for Removal Efficiency by Particle Size; 2012, with 2015 amendments.
- B. UL 900 - Standard for Air Filter Units; Current Edition, Including All Revisions.

1.3 SUBMITTALS

- A. See Division 1 Section - Administrative Requirements, for submittal procedures.
- B. Product Data: Provide data on filter media, filter performance data, filter assembly and filter frames, dimensions, motor locations and electrical characteristics and connection requirements.
- C. Shop Drawings: Indicate filter assembly and filter frames, dimensions, motor locations, and electrical characteristics and connection requirements.

1.4 EXTRA MATERIALS

- A. Provide one set of disposable panel filters. Filters shall be delivered to Owner.

PART 2 PRODUCTS

2.1 FILTER MANUFACTURERS

- A. American Filtration Inc; _____: www.americanfiltration.com/#sle.
- B. AAF International/American Air Filter; _____: www.aafintl.com/#sle.
- C. The Camfil Group; _____: www.camfilfarr.com/#sle.

2.2 DISPOSABLE, EXTENDED AREA PANEL FILTERS

- A. Media: UL 900 Class 1, pleated, lofted, non-woven, reinforced cotton fabric; supported and bonded to welded wire grid by corrugated aluminum separators.
 - 1. Frame: Non-flammable.
 - 2. Nominal thickness: 1 inch.
- B. Minimum Efficiency Reporting Value (MERV): 8, when tested in accordance with ASHRAE Std 52.2.

2.3 DISPOSABLE PANEL FILTERS

- A. Media: UL 900 Class 2, fiber blanket, factory sprayed with flameproof, non-drip, non-volatile adhesive.
 - 1. Thickness: 1 inch.
- B. Performance Rating:
 - 1. Face Velocity: 500 FPM.
 - 2. Initial Resistance: 0.15 inch WG.
 - 3. Recommended Final Resistance: 0.50 inches WG.
- C. Casing: Cardboard frame.

PART 3 EXECUTION

3.1 INSTALLATION

- A. Install air cleaning devices in accordance with manufacturer's instructions.
- B. Prevent passage of unfiltered air around filters with felt, rubber, or neoprene gaskets.
- C. Do not operate fan system until filters (temporary or permanent) are in place. Replace temporary filters used during construction and testing, with clean set.

- D. Ensure that filters are easily removable from equipment, and that access is not blocked by other installations.

END OF SECTION 234000

SECTION 237223
PACKAGED AIR-TO-AIR ENERGY RECOVERY UNITS

PART 1 GENERAL

1.1 SECTION INCLUDES

- A. Energy recovery units.

1.2 REFERENCE STANDARDS

1.3 SUBMITTALS

- A. Product Data: Manufacturer's installation instruction, product data, and engineering calculations.
- B. Shop Drawings: Show design and assembly of energy recovery unit and installation and connection details.

1.4 QUALITY ASSURANCE

- A. Manufacturer Qualifications:
 - 1. Firm regularly engaged in manufacturing energy recovery units.
 - 2. Products in satisfactory use in similar service for not less than five years.

1.5 WARRANTY

- A. See Section 017800 - Closeout Submittals, for additional warranty requirements.
- B. Warranty ventilator to be free from defects in material and workmanship and of all parts for period of 1-1/2 years from date of Substantial Completion.

PART 2 PRODUCTS

2.1 MANUFACTURERS

- A. Energy Recovery Ventilators:
 - 1. Panasonic Corporation of North America; _____: www.panasonic.com/#sle.
 - 2. Swegon North America.

2.2 ENERGY RECOVERY DESIGN CRITERIA: ON DRAWINGS

2.3 ENERGY RECOVERY UNITS

- A. Energy Recovery Units for Spot Ventilation or Whole House Ventilation: Prefabricated packaged system designed by manufacturer with stationary core.
 - 1. Access: Hinged and/or screwed access panels on front.
 - 2. Provide with MERV 8 filters on supply and exhaust air ducts.
 - 3. Provide exterior wall cap.
 - 4. Permanent name plate listing manufacturer mounted inside door near electrical panel.

PART 3 EXECUTION

3.1 INSTALLATION

- A. Provide openings for suitable ductwork connection.

3.2 CLEANING

- A. Clean filters, air plenums, interior and exposed-to-view surfaces prior to Substantial Completion.

END OF SECTION 237223

SECTION 238115
PACKAGED VERTICAL HEAT PUMPS

PART 1 GENERAL

1.1 SECTION INCLUDES

- A. Electric heat pump packaged units.

1.2 RELATED SECTIONS

- A. 233100 - HVAC Ducts and Casings
- B. 233300 - Air Duct Accessories
- C. 234000 - HVAC Air Cleaning Devices

1.3 REFERENCES

- A. ANSI/AHRI 390: Performance Rating of Single Package Vertical Air-Conditioners and Heat Pumps.

1.4 SUBMITTALS

- A. Submit under provisions of Division 1 - Administrative Requirements.
- B. Product Data: Manufacturer's data sheets on each product to be used, including:
 - 1. Preparation instructions and recommendations.
 - 2. Storage and handling requirements and recommendations.
 - 3. Installation methods.
- C. Shop Drawings and Wiring Schematics: Provide detailed physical layout and wiring schematics for installation.

1.5 QUALITY ASSURANCE

- A. Manufacturer Qualifications: Minimum 5 year experience manufacturing similar products.
- B. Installer Qualifications: Minimum 2 year experience installing similar products.

1.6 DELIVERY, STORAGE, AND HANDLING

- A. Deliver and store products in manufacturer's unopened packaging bearing the brand name and manufacturer's identification until ready for installation.
- B. Handle materials as recommended by manufacturer to avoid damage.

1.7 PROJECT CONDITIONS

- A. Maintain environmental conditions (temperature, humidity, and ventilation) within limits recommended by manufacturer for optimum results. Do not install products under environmental conditions outside manufacturer's recommended limits.

1.8 SEQUENCING

- A. Ensure that products of this section are supplied to affected trades in time to prevent interruption of construction progress.

PART 2 PRODUCTS

2.1 MANUFACTURERS

- A. Magic-Pak
- B. Friedrich
- C. Approved substitution.

2.2 ELECTRIC HEAT PUMP SINGLE PACKAGE VERTICAL UNITS

- A. MHP4 M-Series Model Units: Electric Heat Pump as manufactured by Allied Air Enterprises LLC, A Lennox International Inc. Company.
 - 1. Capacity as indicated on drawings
 - 2. Construction:
 - a. Up to 10.4 EER cooling efficiency.

- b. 3.0 COP.
- c. Completely self-contained heating and cooling package.
 - 1) No outside condensing unit.
 - 2) No external refrigerant lines.
 - 3) No separate cooling coil.
 - 4) No additional drain pan required
- d. Pre-wired and pre-charged.
- e. Individually metered and controlled.
- f. Easy service access.
- g. Louver color options to match building facade.
- 3. Refrigerant System:
 - a. R410-A Refrigerant.
 - b. Rifled copper tubing with lanced fin coils.
- 4. Cabinet:
 - a. Fully insulated cabinet for quiet operation.
 - b. Wall sleeve as scheduled or indicated.
 - c. Cabinet air leakage rate shall be less than 2% of total airflow when tested in accordance with ASHRAE 193.
- 5. Blower:
 - a. Four-speed permanently lubricated motor for low maintenance, maximum efficiency and wide airflow range.
 - b. PSC permanently lubricated motor for low maintenance and maximum efficiency.
 - c. Dynamically balanced blower with resilient motor mounts for smooth and quiet operation.
 - d. Internal washable filter.
- 6. Controls:
 - a. Color coded wiring for easy service.
 - b. Fuse protection on 24V circuit.
- 7. Installation:
 - a. Easy to install and service.
 - b. Louver mounts flush to outside wall.
 - c. External utility connections high and low voltage lines.
- 8. Warranty:
 - a. 5 year limited warranty on all parts.

PART 3 EXECUTION

3.1 EXAMINATION

- A. Do not begin installation until wall openings and rough-in have been properly prepared.
- B. If preparation is the responsibility of another installer, notify Architect of unsatisfactory preparation before proceeding.

3.2 PREPARATION

- A. Prepare conditions using the methods recommended by the manufacturer for achieving the best result for the operation under the project conditions.

3.3 INSTALLATION

- A. Install in accordance with manufacturer's instructions. Test for proper operation and adjust as required until satisfactory results are obtained.

3.4 PROTECTION

- A. Protect installed products until completion of project.
- B. Touch-up, repair or replace damaged products before Substantial Completion.

END OF SECTION 238115

SECTION 238126.13
SMALL-CAPACITY SPLIT-SYSTEM AIR CONDITIONERS

PART 1 GENERAL

1.1 SECTION INCLUDES

- A. Air-source heat pumps.
- B. Indoor air handling (fan and coil) units for ducted systems.
- C. Controls.

1.2 RELATED REQUIREMENTS

- A. Section 233100 - HVAC Ducts and Casings.
- B. Section 260583 - Wiring Connections: Electrical characteristics and wiring connections and installation and wiring of thermostats and other controls components.

1.3 REFERENCE STANDARDS

- A. AHRI 210/240 - Standard for Performance Rating of Unitary Air-Conditioning and Air-Source Heat Pump Equipment; 2008.
- B. AHRI 520 - Performance Rating of Positive Displacement Condensing Units; 2004.
- C. ASHRAE Std 15 - Safety Standard for Refrigeration Systems; 2013.
- D. ASHRAE Std 23.1 - Methods of Testing for Rating Positive Displacement Refrigerant Compressors and Condensing Units; 2010.
- E. NEMA MG 1 - Motors and Generators; 2014.
- F. NFPA 90A - Standard for the Installation of Air-Conditioning and Ventilating Systems; 2015.
- G. NFPA 90B - Standard for the Installation of Warm Air Heating and Air-Conditioning Systems; 2015.
- H. UL 207 - Standard for Refrigerant-Containing Components and Accessories, Nonelectrical; Current Edition, Including All Revisions.

1.4 SUBMITTALS

- A. Product Data: Provide rated capacities, weights, accessories, electrical nameplate data, and wiring diagrams.
- B. Shop Drawings: Indicate assembly, required clearances, and location and size of field connections.
- C. Design Data: Indicate refrigerant pipe sizing.
- D. Manufacturer's Instructions: Indicate rigging, assembly, and installation instructions.
- E. Operation and Maintenance Data: Include manufacturer's descriptive literature, operating instructions, installation instructions, maintenance and repair data, and parts listing.
- F. Warranty: Submit manufacturers warranty and ensure forms have been filled out in Owner's name and registered with manufacturer.
- G. Maintenance Materials: Furnish the following for Owner's use in maintenance of project.
 - 1. Extra Filters: One for each unit.

1.5 WARRANTY

- A. Provide five year manufacturers warranty for heat exchangers.
- B. Provide five year manufacturers warranty for compressors.

PART 2 PRODUCTS

2.1 MANUFACTURERS

- A. Mitsubishi.
- B. Approved substitutions meeting or exceeding requirements of scheduled products.

2.2 SYSTEM DESIGN

- A. Split-System Heating and Cooling Units: Self-contained, packaged, matched factory-engineered and assembled, pre-wired indoor and outdoor units; UL listed.
 - 1. Heating and Cooling: Air-source electric heat pump located in outdoor unit with evaporator.
 - 2. Provide refrigerant lines internal to units and between indoor and outdoor units, factory cleaned, dried, pressurized and sealed, with insulated suction line.
- B. Performance Requirements: See Drawings for additional requirements.

2.3 INDOOR AIR HANDLING UNITS FOR DUCTED SYSTEMS

- A. Indoor Units: Self-contained, packaged, factory assembled, pre-wired unit consisting of cabinet, supply fan, heating and cooling element(s), controls, and accessories; wired for single power connection with control transformer.
 - 1. Air Flow Configuration: As indicated on drawings.
 - 2. Cabinet: Steel with baked enamel finish, easily removed and secured access doors with safety interlock switches, glass fiber insulation with reflective liner. Cabinet air leakage rate shall be less than 2% of total airflow when tested in accordance with ASHRAE 193.
- B. Supply Fan: Centrifugal type rubber mounted with direct or belt drive with adjustable variable pitch motor pulley.
 - 1. Motor: NEMA MG 1; 1750 rpm single speed, permanently lubricated, hinge mounted.
 - 2. Motor Electrical Characteristics:
- C. Air Filters: 1 inch thick urethane, washable type arranged for easy replacement.
- D. Evaporator Coils: Copper tube aluminum fin assembly, galvanized or polymer drain pan sloped in all directions to drain, drain connection, refrigerant piping connections, restricted distributor or thermostatic expansion valve.
 - 1. Construction and Ratings: In accordance with AHRI 210/240 and UL 207.
 - 2. Manufacturers: System manufacturer.

2.4 OUTDOOR UNITS

- A. Outdoor Units: Self-contained, packaged, pre-wired unit consisting of cabinet, with compressors and condenser.
 - 1. Refrigerant: R-410A.
 - 2. Construction and Ratings: In accordance with AHRI 210/240 with testing in accordance with ASHRAE Std 23.1 and UL 207.
- B. Compressor: Scroll, 3600 rpm, AHRI 520 resiliently mounted integral with condenser, with positive lubrication, crankcase heater, high pressure control, motor overload protection, service valves and drier. Provide time delay control to prevent short cycling.
- C. Air Cooled Condenser: Aluminum fin and copper tube coil, AHRI 520 with direct drive axial propeller fan resiliently mounted, galvanized fan guard.
- D. Accessories: Filter drier, high pressure switch (manual reset), low pressure switch (automatic reset), service valves and gauge ports, thermometer well (in liquid line).
 - 1. Provide thermostatic expansion valves.
 - 2. Provide heat pump reversing valves.
 - 3. Provide capacity control valve, Rawal APR or equivalent in lead refrigerant circuit.
- E. Operating Controls:
 - 1. Control by programmable room thermostat to maintain room temperature setting.

2.5 ACCESSORY EQUIPMENT

- A. Room Thermostat: Wall-mounted, electric solid state microcomputer based room thermostat with remote sensor to maintain temperature setting; low-voltage; with following features:
 - 1. Automatic switching from heating to cooling.
 - 2. Preferential rate control to minimize overshoot and deviation from setpoint.
 - 3. Set-up for four separate temperatures per day.

4. Programming based on weekdays, Saturday and Sunday.
5. Thermostat Display:
 - a. Actual room temperature.
 - b. Programmed temperature.
 - c. System Mode Indication: Heating, Cooling, Fan Auto, Off, and On, Auto or On, Off.

PART 3 EXECUTION

3.1 INSTALLATION

- A. Install in accordance with manufacturer's instructions and requirements of local authorities having jurisdiction.
- B. Install in accordance with NFPA 90A and NFPA 90B.
- C. Install refrigeration systems in accordance with ASHRAE Std 15.
- D. Pipe drain from blower coil to nearest floor drain.

END OF SECTION 238126.13

SECTION 260519

LOW-VOLTAGE ELECTRICAL POWER CONDUCTORS AND CABLES

PART 1 GENERAL

1.1 SECTION INCLUDES

- A. Single conductor building wire.
- B. Nonmetallic-sheathed cable.
- C. Metal-clad cable.
- D. Power and control tray cable.
- E. Wiring connectors.
- F. Electrical tape.
- G. Oxide inhibiting compound.
- H. Wire pulling lubricant.
- I. Cable ties.

1.2 RELATED REQUIREMENTS

- A. Section 260526 - Grounding and Bonding for Electrical Systems: Additional requirements for grounding conductors and grounding connectors.
- B. Section 260553 - Identification for Electrical Systems: Identification products and requirements.
- C. Section 284600 - Fire Detection and Alarm: Fire alarm system conductors and cables.

1.3 REFERENCE STANDARDS

- A. ASTM B3 - Standard Specification for Soft or Annealed Copper Wire; 2013.
- B. ASTM B8 - Standard Specification for Concentric-Lay-Stranded Copper Conductors, Hard, Medium-Hard, or Soft; 2011.
- C. ASTM B33 - Standard Specification for Tin-Coated Soft or Annealed Copper Wire for Electrical Purposes; 2010 (Reapproved 2014).
- D. ASTM B787/B787M - Standard Specification for 19 Wire Combination Unilay-Stranded Copper Conductors for Subsequent Insulation; 2004 (Reapproved 2014).
- E. ASTM B800 - Standard Specification for 8000 Series Aluminum Alloy Wire for Electrical Purposes - Annealed and Intermediate Tempers; 2005 (Reapproved 2011).
- F. ASTM B801 - Standard Specification for Concentric-Lay-Stranded Conductors of 8000 Series Aluminum Alloy Wire for Subsequent Covering of Insulation; 2007 (Reapproved 2012).
- G. ASTM D3005 - Standard Specification for Low-Temperature Resistant Vinyl Chloride Plastic Pressure-Sensitive Electrical Insulating Tape; 2010.
- H. NECA 1 - Standard for Good Workmanship in Electrical Construction; 2010.
- I. NECA 104 - Recommended Practice for Installing Aluminum Building Wire and Cable; 2012.
- J. NECA 120 - Standard for Installing Armored Cable (AC) and Metal-Clad Cable (MC); 2012.
- K. NEMA WC 70 - Nonshielded Power Cable 2000 V or Less for the Distribution of Electrical Energy; 2009.
- L. NFPA 70 - National Electrical Code; Most Recent Edition Adopted by Authority Having Jurisdiction, Including All Applicable Amendments and Supplements.
- M. UL 44 - Thermoset-Insulated Wires and Cables; Current Edition, Including All Revisions.
- N. UL 83 - Thermoplastic-Insulated Wires and Cables; Current Edition, Including All Revisions.
- O. UL 486A-486B - Wire Connectors; Current Edition, Including All Revisions.
- P. UL 486C - Splicing Wire Connectors; Current Edition, Including All Revisions.

- Q. UL 510 - Polyvinyl Chloride, Polyethylene, and Rubber Insulating Tape; Current Edition, Including All Revisions.
- R. UL 1277 - Electrical Power and Control Tray Cables with Optional Optical-Fiber Members; Current Edition, Including All Revisions.
- S. UL 1569 - Metal-Clad Cables; Current Edition, Including All Revisions.

1.4 ADMINISTRATIVE REQUIREMENTS

- A. Coordination:
 - 1. Coordinate sizes of raceways, boxes, and equipment enclosures installed under other sections with the actual conductors to be installed, including adjustments for conductor sizes increased for voltage drop.
 - 2. Coordinate with electrical equipment installed under other sections to provide terminations suitable for use with the conductors to be installed.
 - 3. Notify Architect of any conflicts with or deviations from Contract Documents. Obtain direction before proceeding with work.

1.5 SUBMITTALS

- A. See Section 013000 - Administrative Requirements, for submittal procedures.
- B. Product Data: Provide manufacturer's standard catalog pages and data sheets for conductors and cables, including detailed information on materials, construction, ratings, listings, and available sizes, configurations, and stranding.
- C. Design Data: Indicate voltage drop and ampacity calculations for aluminum conductors substituted for copper conductors. Include proposed modifications to raceways, boxes, wiring gutters, enclosures, etc. to accommodate substituted conductors.
- D. Project Record Documents: Record actual installed circuiting arrangements. Record actual routing for underground circuits.

1.6 QUALITY ASSURANCE

- A. Comply with requirements of NFPA 70.

1.7 DELIVERY, STORAGE, AND HANDLING

- A. Receive, inspect, handle, and store conductors and cables in accordance with manufacturer's instructions.

1.8 FIELD CONDITIONS

- A. Do not install or otherwise handle thermoplastic-insulated conductors at temperatures lower than 14 degrees F, unless otherwise permitted by manufacturer's instructions. When installation below this temperature is unavoidable, notify Architect and obtain direction before proceeding with work.

PART 2 PRODUCTS

2.1 CONDUCTOR AND CABLE APPLICATIONS

- A. Do not use conductors and cables for applications other than as permitted by NFPA 70 and product listing.
- B. Provide single conductor building wire installed in suitable raceway unless otherwise indicated, permitted, or required.
- C. Nonmetallic-sheathed cable is not permitted.
 - 1. Where not otherwise restricted, may be used:
 - a. For branch circuiting within apartments only.
 - 2. In addition to other applicable restrictions, may not be used:
 - a. Unless approved by Authority Having Jurisdiction.
- D. Underground feeder and branch-circuit cable is not permitted.
- E. Service entrance cable is not permitted.
- F. Armored cable is not permitted.

- G. Metal-clad cable is not permitted.
 - 1. Where not otherwise restricted, may be used:
 - a. Where concealed above accessible ceilings for final connections from junction boxes to luminaires.
 - 1) Maximum Length: 6 feet.
 - 2. In addition to other applicable restrictions, may not be used:
 - a. Unless approved by Owner.
 - b. Where not approved for use by the authority having jurisdiction.
 - c. Where exposed to damage.
 - d. For damp, wet, or corrosive locations.
 - 3. Base bid shall include limited use of MC cable as described above. Provide alternate pricing to Owner for use of MC cable for branch circuitry where allowed per NEC.

2.2 CONDUCTOR AND CABLE MANUFACTURERS

- A. AFC Cable Systems: www.afcweb.com
- B. Alan Wire Company: www.alanwire.com.
- C. Cerro Wire LLC: www.cerrowire.com.
- D. Encore Wire Corporation: www.encorewire.com.
- E. Southwire Company: www.southwire.com.
- F. Substitutions: See Section 016000 - Product Requirements.

2.3 CONDUCTOR AND CABLE GENERAL REQUIREMENTS

- A. Provide products that comply with requirements of NFPA 70.
- B. Provide products listed, classified, and labeled as suitable for the purpose intended.
- C. Unless specifically indicated to be excluded, provide all required conduit, boxes, wiring, connectors, etc. as required for a complete operating system.
- D. Comply with NEMA WC 70.
- E. Thermoplastic-Insulated Conductors and Cables: Listed and labeled as complying with UL 83.
- F. Thermoset-Insulated Conductors and Cables: Listed and labeled as complying with UL 44.
- G. Conductor Material:
 - 1. Provide copper conductors only. Aluminum conductors may be bid as an alternate only where indicated on drawings. Conductor sizes indicated are based on copper.
 - 2. Copper Conductors: Soft drawn annealed, 98 percent conductivity, uncoated copper conductors complying with ASTM B3, ASTM B8, or ASTM B787/B787M unless otherwise indicated.
 - 3. Tinned Copper Conductors: Comply with ASTM B33.
- H. Minimum Conductor Size:
 - 1. Branch Circuits: 12 AWG.
 - a. Exceptions:
 - 1) 20 A, 120 V circuits longer than 75 feet: 10 AWG, for voltage drop.
 - 2) 20 A, 120 V circuits longer than 150 feet: 8 AWG, for voltage drop.
 - 3) 20 A, 277 V circuits longer than 150 feet: 10 AWG, for voltage drop.
 - 2. Control Circuits: 14 AWG.
- I. Conductor Color Coding:
 - 1. Color code conductors as indicated unless otherwise required by the authority having jurisdiction. Maintain consistent color coding throughout project.
 - 2. Color Coding Method: Integrally colored insulation.
 - a. Conductors size 4 AWG and larger may have black insulation color coded using vinyl color coding electrical tape.
 - 3. Color Code:
 - a. 240/120 V, 1 Phase, 3 Wire System:

- 1) Phase A: Black.
- 2) Phase B: Red.
- 3) Neutral/Grounded: White.
- b. Equipment Ground, All Systems: Green.
- c. Travelers for 3-Way and 4-Way Switching: Pink.
- d. For control circuits, comply with manufacturer's recommended color code.

2.4 SINGLE CONDUCTOR BUILDING WIRE

- A. Description: Single conductor insulated wire.
- B. Conductor Stranding:
 1. Feeders and Branch Circuits:
 - a. Size 10 AWG and Smaller: Solid.
 - b. Size 8 AWG and Larger: Stranded.
 2. Control Circuits: Stranded.
- C. Insulation Voltage Rating: 600 V.
- D. Insulation:
 1. Copper Building Wire: Type THHN/THWN or THHN/THWN-2.

2.5 METAL-CLAD CABLE

- A. Description: NFPA 70, Type MC cable listed and labeled as complying with UL 1569, and listed for use in classified firestop systems to be used.
- B. Conductor Stranding:
 1. Size 10 AWG and Smaller: Solid.
 2. Size 8 AWG and Larger: Stranded.
- C. Insulation Voltage Rating: 600 V.
- D. Insulation: Type THHN, THHN/THWN, or THHN/THWN-2.
- E. Grounding: Full-size integral equipment grounding conductor.
- F. Armor: Aluminum or steel, interlocked tape.
- G. Provide PVC jacket applied over cable armor where indicated or required for environment of installed location.

2.6 POWER AND CONTROL TRAY CABLE

- A. Description: NFPA 70, Type TC cable listed and labeled as complying with UL 1277.
- B. Conductor Stranding: Stranded.
- C. Insulation Voltage Rating: 600 V.
- D. Insulation: Type THHN/THWN, THHN/THWN-2, XHHW, or XHHW-2.
- E. Jacket: PVC or Chlorinated Polyethylene (CPE).

2.7 WIRING CONNECTORS

- A. Description: Wiring connectors appropriate for the application, suitable for use with the conductors to be connected, and listed as complying with UL 486A-486B or UL 486C as applicable.
- B. Wiring Connectors for Splices and Taps:
 1. Copper Conductors Size 8 AWG and Smaller: Use twist-on insulated spring connectors.
 2. Copper Conductors Size 6 AWG and Larger: Use mechanical connectors or compression connectors.
- C. Wiring Connectors for Terminations:
 1. Provide terminal lugs for connecting conductors to equipment furnished with terminations designed for terminal lugs.
 2. Provide compression adapters for connecting conductors to equipment furnished with mechanical lugs when only compression connectors are specified.

3. Where over-sized conductors are larger than the equipment terminations can accommodate, provide connectors suitable for reducing to appropriate size, but not less than required for the rating of the overcurrent protective device.
 4. Copper Conductors Size 8 AWG and Larger: Use mechanical connectors or compression connectors where connectors are required.
 5. Stranded Conductors Size 10 AWG and Smaller: Use crimped terminals for connections to terminal screws.
 6. Conductors for Control Circuits: Use crimped terminals for all connections.
- D. Do not use insulation-piercing or insulation-displacement connectors designed for use with conductors without stripping insulation.
 - E. Do not use push-in wire connectors as a substitute for twist-on insulated spring connectors.
 - F. Twist-on Insulated Spring Connectors: Rated 600 V, 221 degrees F for standard applications and 302 degrees F for high temperature applications; pre-filled with sealant and listed as complying with UL 486D for damp and wet locations.
 - G. Mechanical Connectors: Provide bolted type or set-screw type.
 - H. Compression Connectors: Provide circumferential type or hex type crimp configuration.
 - I. Crimped Terminals: Nylon-insulated, with insulation grip and terminal configuration suitable for connection to be made.

2.8 ACCESSORIES

- A. Electrical Tape:
 1. Manufacturers:
 - a. 3M: www.3m.com/#sle.
 - b. Plymouth Rubber Europa: www.plymouthrubber.com/#sle.
 2. Vinyl Color Coding Electrical Tape: Integrally colored to match color code indicated; listed as complying with UL 510; minimum thickness of 7 mil; resistant to abrasion, corrosion, and sunlight; suitable for continuous temperature environment up to 221 degrees F.
 3. Vinyl Insulating Electrical Tape: Complying with ASTM D3005 and listed as complying with UL 510; minimum thickness of 7 mil; resistant to abrasion, corrosion, and sunlight; conformable for application down to 0 degrees F and suitable for continuous temperature environment up to 221 degrees F.
- B. Oxide Inhibiting Compound: Listed; suitable for use with the conductors or cables to be installed.
- C. Wire Pulling Lubricant: Listed; suitable for use with the conductors or cables to be installed and suitable for use at the installation temperature.
- D. Cable Ties: Material and tensile strength rating suitable for application.

PART 3 EXECUTION

3.1 EXAMINATION

- A. Verify that interior of building has been protected from weather.
- B. Verify that work likely to damage wire and cable has been completed.
- C. Verify that raceways, boxes, and equipment enclosures are installed and are properly sized to accommodate conductors and cables in accordance with NFPA 70.
- D. Verify that field measurements are as indicated.
- E. Verify that conditions are satisfactory for installation prior to starting work.

3.2 PREPARATION

- A. Clean raceways thoroughly to remove foreign materials before installing conductors and cables.

3.3 INSTALLATION

- A. Circuiting Requirements:
 1. Unless dimensioned, circuit routing indicated is diagrammatic.

2. When circuit destination is indicated without specific routing, determine exact routing required.
 3. Arrange circuiting to minimize splices.
 4. Include circuit lengths required to install connected devices within 10 ft of location indicated.
 5. Maintain separation of Class 1, Class 2, and Class 3 remote-control, signaling, and power-limited circuits in accordance with NFPA 70.
 6. Circuiting Adjustments: Unless otherwise indicated, when branch circuits are indicated as separate, combining them together in a single raceway is not permitted.
 - a. Provide no more than six current-carrying conductors in a single raceway. Dedicated neutral conductors are considered current-carrying conductors.
 7. Common Neutrals: Unless otherwise indicated, sharing of neutral/grounded conductors among single phase branch circuits of different phases installed in the same raceway is not permitted. Provide dedicated neutral/grounded conductor for each individual branch circuit.
- B. Install products in accordance with manufacturer's instructions.
- C. Perform work in accordance with NECA 1 (general workmanship).
- D. Install nonmetallic-sheathed cable (Type NM-B) in accordance with NECA 121.
- E. Install metal-clad cable (Type MC) in accordance with NECA 120.
- F. Installation in Raceway:
1. Tape ends of conductors and cables to prevent infiltration of moisture and other contaminants.
 2. Pull all conductors and cables together into raceway at same time.
 3. Do not damage conductors and cables or exceed manufacturer's recommended maximum pulling tension and sidewall pressure.
 4. Use suitable wire pulling lubricant where necessary, except when lubricant is not recommended by the manufacturer.
- G. Paralleled Conductors: Install conductors of the same length and terminate in the same manner.
- H. Secure and support conductors and cables in accordance with NFPA 70 using suitable supports and methods approved by the authority having jurisdiction. Provide independent support from building structure. Do not provide support from raceways, piping, ductwork, or other systems.
1. Installation Above Suspended Ceilings: Do not provide support from ceiling support system. Do not provide support from ceiling grid or allow conductors and cables to lay on ceiling tiles.
- I. Terminate cables using suitable fittings.
1. Metal-Clad Cable (Type MC):
 - a. Use listed fittings.
 - b. Cut cable armor only using specialized tools to prevent damaging conductors or insulation. Do not use hacksaw or wire cutters to cut armor.
 - c. Do not use direct-bearing set-screw type fittings for cables with aluminum armor.
- J. Install conductors with a minimum of 12 inches of slack at each outlet.
- K. Neatly train and bundle conductors inside boxes, wireways, panelboards and other equipment enclosures.
- L. Group or otherwise identify neutral/grounded conductors with associated ungrounded conductors inside enclosures in accordance with NFPA 70.
- M. Make wiring connections using specified wiring connectors.
1. Make splices and taps only in accessible boxes. Do not pull splices into raceways or make splices in conduit bodies or wiring gutters.
 2. Remove appropriate amount of conductor insulation for making connections without cutting, nicking or damaging conductors.
 3. Do not remove conductor strands to facilitate insertion into connector.
 4. Clean contact surfaces on conductors and connectors to suitably remove corrosion, oxides, and other contaminants. Do not use wire brush on plated connector surfaces.
 5. Mechanical Connectors: Secure connections according to manufacturer's recommended torque settings.
 6. Compression Connectors: Secure connections using manufacturer's recommended tools and dies.

- N. Insulate splices and taps that are made with uninsulated connectors using methods suitable for the application, with insulation and mechanical strength at least equivalent to unspliced conductors.
 - 1. Dry Locations: Use insulating covers specifically designed for the connectors, electrical tape, or heat shrink tubing.
 - a. For taped connections, first apply adequate amount of rubber splicing electrical tape or electrical filler tape, followed by outer covering of vinyl insulating electrical tape.
 - 2. Damp Locations: Use insulating covers specifically designed for the connectors, electrical tape, or heat shrink tubing.
 - a. For connections with insulating covers, apply outer covering of moisture sealing electrical tape.
 - b. For taped connections, follow same procedure as for dry locations but apply outer covering of moisture sealing electrical tape.
 - 3. Wet Locations: Use heat shrink tubing.
 - O. Insulate ends of spare conductors using vinyl insulating electrical tape.
 - P. Field-Applied Color Coding: Where vinyl color coding electrical tape is used in lieu of integrally colored insulation as permitted in Part 2 under "Color Coding", apply half overlapping turns of tape at each termination and at each location conductors are accessible.
 - Q. Identify conductors and cables in accordance with Section 260553.
 - R. Install firestopping to preserve fire resistance rating of partitions and other elements, using materials and methods specified in Section 078400.
 - S. Unless specifically indicated to be excluded, provide final connections to all equipment and devices, including those furnished by others, as required for a complete operating system.
- 3.4 FIELD QUALITY CONTROL
- A. See Section 014000 - Quality Requirements, for additional requirements.
 - B. Perform inspection, testing, and adjusting in accordance with Section 014000.
 - C. Correct deficiencies and replace damaged or defective conductors and cables.

END OF SECTION 260519

SECTION 260526
GROUNDING AND BONDING FOR ELECTRICAL SYSTEMS

PART 1 GENERAL

1.1 SECTION INCLUDES

- A. Grounding and bonding requirements.
- B. Conductors for grounding and bonding.
- C. Connectors for grounding and bonding.
- D. Ground bars.
- E. Ground rod electrodes.
- F. Grounding and bonding components.
- G. Provide all components necessary to complete the grounding system(s) consisting of:
 - 1. Metal underground water pipe.
 - 2. Metal frame of the building.
 - 3. Concrete-encased electrode.
 - 4. Metal underground gas piping system.
 - 5. Rod electrodes.

1.2 REFERENCE STANDARDS

- A. IEEE 81 - IEEE Guide for Measuring Earth Resistivity, Ground Impedance, and Earth Surface Potentials of a Grounding System; 2012.
- B. NECA 1 - Standard for Good Workmanship in Electrical Construction; 2010.
- C. NEMA GR 1 - Grounding Rod Electrodes and Grounding Rod Electrode Couplings; 2007.
- D. NFPA 70 - National Electrical Code; Most Recent Edition Adopted by Authority Having Jurisdiction, Including All Applicable Amendments and Supplements.
- E. UL 467 - Grounding and Bonding Equipment; Current Edition, Including All Revisions.

1.3 ADMINISTRATIVE REQUIREMENTS

- A. Coordination:
 - 1. Verify exact locations of underground metal water service pipe entrances to building.
 - 2. Coordinate the work with other trades to provide steel reinforcement complying with specified requirements for concrete-encased electrode.
 - 3. Notify Architect of any conflicts with or deviations from Contract Documents. Obtain direction before proceeding with work.
- B. Sequencing:
 - 1. Do not install ground rod electrodes until final backfill and compaction is complete.

1.4 PERFORMANCE REQUIREMENTS

- A. Grounding System Resistance: 25 ohms.

1.5 SUBMITTALS

- A. See Section 013000 - Administrative Requirements for submittals procedures.
- B. Product Data: Provide manufacturer's standard catalog pages and data sheets for grounding and bonding system components.
- C. Test Reports: Indicate overall resistance to ground .
- D. Project Record Documents: Record actual locations of grounding electrode system components and connections.

1.6 QUALITY ASSURANCE

- A. Comply with requirements of NFPA 70.

- B. Manufacturer Qualifications: Company specializing in manufacturing the products specified in this section with minimum three years documented experience.
- C. Installer Qualifications for Signal Reference Grids: Company with minimum five years documented experience with high frequency grounding systems.
- D. Product Listing Organization Qualifications: An organization recognized by OSHA as a Nationally Recognized Testing Laboratory (NRTL) and acceptable to authorities having jurisdiction.

1.7 DELIVERY, STORAGE, AND HANDLING

- A. Receive, inspect, handle, and store products in accordance with manufacturer's instructions.

PART 2 PRODUCTS

2.1 GROUNDING AND BONDING REQUIREMENTS

- A. Do not use products for applications other than as permitted by NFPA 70 and product listing.
- B. Unless specifically indicated to be excluded, provide all required components, conductors, connectors, conduit, boxes, fittings, supports, accessories, etc. as necessary for a complete grounding and bonding system.
- C. Where conductor size is not indicated, size to comply with NFPA 70 but not less than applicable minimum size requirements specified.
- D. Grounding System Resistance:
 1. Achieve specified grounding system resistance under normally dry conditions unless otherwise approved by Architect. Precipitation within the previous 48 hours does not constitute normally dry conditions.
 2. Grounding Electrode System: Not greater than 25 ohms to ground, when tested according to IEEE 81 using "fall-of-potential" method.
- E. Grounding Electrode System:
 1. Provide connection to required and supplemental grounding electrodes indicated to form grounding electrode system.
 - a. Provide continuous grounding electrode conductors without splice or joint.
 - b. Install grounding electrode conductors in raceway where exposed to physical damage. Bond grounding electrode conductor to metallic raceways at each end with bonding jumper.
 2. Metal Underground Water Pipe(s):
 - a. Provide connection to underground metal domestic and fire protection (where present) water service pipe(s) that are in direct contact with earth for at least 10 feet at an accessible location not more than 5 feet from the point of entrance to the building.
 - b. Provide bonding jumper(s) around insulating joints/pipes as required to make pipe electrically continuous.
 - c. Provide bonding jumper around water meter of sufficient length to permit removal of meter without disconnecting jumper.
 3. Metal In-Ground Support Structure:
 - a. Provide connection to metal in-ground support structure that is in direct contact with earth in accordance with NFPA 70.
 4. Concrete-Encased Electrode:
 - a. Provide connection to concrete-encased electrode consisting of not less than 20 feet of either steel reinforcing bars or bare copper conductor not smaller than 4 AWG embedded within concrete foundation or footing that is in direct contact with earth in accordance with NFPA 70.
 5. Ground Rod Electrode(s):
 - a. Provide single electrode unless otherwise indicated or required.
 - b. Space electrodes not less than 10 feet from each other and any other ground electrode.
 - c. Where location is not indicated, locate electrode(s) at least 5 feet outside building perimeter foundation as near as possible to electrical service entrance; where possible, locate in softscape (uncovered) area.

6. Provide additional ground electrode(s) as required to achieve specified grounding electrode system resistance.
 7. Ground Bar: Provide ground bar, separate from service equipment enclosure, for common connection point of grounding electrode system bonding jumpers as permitted in NFPA 70. Connect grounding electrode conductor provided for service-supplied system grounding to this ground bar.
- F. Service-Supplied System Grounding:
1. For each service disconnect, provide grounding electrode conductor to connect neutral (grounded) service conductor to grounding electrode system. Unless otherwise indicated, make connection at neutral (grounded) bus in service disconnect enclosure.
 2. For each service disconnect, provide main bonding jumper to connect neutral (grounded) bus to equipment ground bus where not factory-installed. Do not make any other connections between neutral (grounded) conductors and ground on load side of service disconnect.
- G. Bonding and Equipment Grounding:
1. Provide bonding for equipment grounding conductors, equipment ground busses, metallic equipment enclosures, metallic raceways and boxes, device grounding terminals, and other normally non-current-carrying conductive materials enclosing electrical conductors/equipment or likely to become energized as indicated and in accordance with NFPA 70.
 2. Provide insulated equipment grounding conductor in each feeder and branch circuit raceway. Do not use raceways as sole equipment grounding conductor.
 3. Where circuit conductor sizes are increased for voltage drop, increase size of equipment grounding conductor proportionally in accordance with NFPA 70.
 4. Unless otherwise indicated, connect wiring device grounding terminal to branch circuit equipment grounding conductor and to outlet box with bonding jumper.
 5. Terminate branch circuit equipment grounding conductors on solidly bonded equipment ground bus only. Do not terminate on neutral (grounded) or isolated/insulated ground bus.
 6. Provide bonding jumper across expansion or expansion/deflection fittings provided to accommodate conduit movement.
 7. Provide bonding for interior metal piping systems in accordance with NFPA 70. This includes, but is not limited to:
 - a. Metal water piping where not already effectively bonded to metal underground water pipe used as grounding electrode.
 - b. Metal gas piping.
- H. Communications Systems Grounding and Bonding:
1. Provide bonding jumper in raceway from intersystem bonding termination to each communications room or backboard and provide ground bar for termination.
 - a. Bonding Jumper Size: As indicated.
 - b. Raceway Size: 3/4 inch trade size unless otherwise indicated or required.
 - c. Ground Bar Size: 1/4 by 2 by 12 inches unless otherwise indicated or required.
 - d. Ground Bar Mounting Height: 18 inches above finished floor unless otherwise indicated.
- I. Pole-Mounted Luminaires: Also comply with Section 265600.

2.2 GROUNDING AND BONDING COMPONENTS

- A. General Requirements:
1. Provide products listed, classified, and labeled as suitable for the purpose intended.
 2. Provide products listed and labeled as complying with UL 467 where applicable.
- B. Conductors for Grounding and Bonding, in Addition to Requirements of Section 260526:
1. Use insulated copper conductors unless otherwise indicated.
 - a. Exceptions:
 - 1) Use bare copper conductors where installed underground in direct contact with earth.
 - 2) Use bare copper conductors where directly encased in concrete (not in raceway).
- C. Connectors for Grounding and Bonding:

1. Description: Connectors appropriate for the application and suitable for the conductors and items to be connected; listed and labeled as complying with UL 467.
 2. Unless otherwise indicated, use exothermic welded connections for underground, concealed and other inaccessible connections.
 3. Unless otherwise indicated, use mechanical connectors, compression connectors, or exothermic welded connections for accessible connections.
 - a. Exceptions:
 - 1) Use exothermic welded connections for connections to metal building frame.
 4. Manufacturers - Mechanical and Compression Connectors:
 - a. Burndy: www.burndy.com.
 - b. Thomas & Betts Corporation: www.tnb.com/#sle.
 5. Manufacturers - Exothermic Welded Connections:
 - a. Burndy: www.burndy.com.
 - b. Cadweld, a brand of Erico International Corporation: www.erico.com/#sle.
 - c. thermOweld, subsidiary of Continental Industries; division of Burndy LLC; _____: www.thermoweld.com/#sle.
- D. Ground Bars:
1. Description: Copper rectangular ground bars with mounting brackets and insulators.
 2. Size: As indicated.
 3. Holes for Connections: As indicated or as required for connections to be made.
- E. Ground Rod Electrodes:
1. Comply with NEMA GR 1.
 2. Material: Copper-bonded (copper-clad) steel.
 3. Size: 3/4 inch diameter by 10 feet length, unless otherwise indicated.

PART 3 EXECUTION

3.1 EXAMINATION

- A. Verify that work likely to damage grounding and bonding system components has been completed.
- B. Verify that field measurements are as indicated.
- C. Verify that conditions are satisfactory for installation prior to starting work.
- D. Verify existing conditions prior to beginning work.
- E. Verify that final backfill and compaction has been completed before driving rod electrodes.

3.2 INSTALLATION

- A. Install products in accordance with manufacturer's instructions.
- B. Perform work in accordance with NECA 1 (general workmanship).
- C. Ground Rod Electrodes: Unless otherwise indicated, install ground rod electrodes vertically. Where encountered rock prohibits vertical installation, install at 45 degree angle or bury horizontally in trench at least 30 inches (750 mm) deep in accordance with NFPA 70 or provide ground plates.
 1. Outdoor Installations: Unless otherwise indicated, install with top of rod 6 inches below finished grade.
- D. Make grounding and bonding connections using specified connectors.
 1. Remove appropriate amount of conductor insulation for making connections without cutting, nicking or damaging conductors. Do not remove conductor strands to facilitate insertion into connector.
 2. Remove nonconductive paint, enamel, or similar coating at threads, contact points, and contact surfaces.
 3. Exothermic Welds: Make connections using molds and weld material suitable for the items to be connected in accordance with manufacturer's recommendations.
 4. Mechanical Connectors: Secure connections according to manufacturer's recommended torque settings.

- 5. Compression Connectors: Secure connections using manufacturer's recommended tools and dies.
- E. Identify grounding and bonding system components in accordance with Section 260553.

3.3 FIELD QUALITY CONTROL

- A. See Section 014000 - Quality Requirements, for additional requirements.
- B. Perform ground electrode resistance tests under normally dry conditions. Precipitation within the previous 48 hours does not constitute normally dry conditions.
- C. Investigate and correct deficiencies where measured ground resistances do not comply with specified requirements.

END OF SECTION 260526

SECTION 260529
HANGERS AND SUPPORTS FOR ELECTRICAL SYSTEMS

PART 1 GENERAL

1.1 SECTION INCLUDES

- A. Support and attachment requirements and components for equipment, conduit, cable, boxes, and other electrical work.

1.2 REFERENCE STANDARDS

- A. ASTM A153/A153M - Standard Specification for Zinc Coating (Hot-Dip) on Iron and Steel Hardware; 2009.
- B. MFMA-4 - Metal Framing Standards Publication; 2004.
- C. NECA 1 - Standard for Good Workmanship in Electrical Construction; 2010.
- D. NFPA 70 - National Electrical Code; Most Recent Edition Adopted by Authority Having Jurisdiction, Including All Applicable Amendments and Supplements.

1.3 SUBMITTALS

- A. See Section 013000 - Administrative Requirements, for submittal procedures.
- B. Product Data: Provide manufacturer's catalog data for fastening systems.

1.4 QUALITY ASSURANCE

- A. Comply with NFPA 70.
- B. Comply with applicable building code.

1.5 DELIVERY, STORAGE, AND HANDLING

- A. Receive, inspect, handle, and store products in accordance with manufacturer's instructions.

PART 2 PRODUCTS

2.1 SUPPORT AND ATTACHMENT COMPONENTS

- A. General Requirements:
 - 1. Provide all required hangers, supports, anchors, fasteners, fittings, accessories, and hardware as necessary for the complete installation of electrical work.
 - 2. Provide products listed, classified, and labeled as suitable for the purpose intended, where applicable.
 - 3. Where support and attachment component types and sizes are not indicated, select in accordance with manufacturer's application criteria as required for the load to be supported. Include consideration for vibration, equipment operation, and shock loads where applicable.
 - 4. Do not use products for applications other than as permitted by NFPA 70 and product listing.
 - 5. Steel Components: Use corrosion resistant materials suitable for the environment where installed.
 - a. Zinc-Plated Steel: Electroplated in accordance with ASTM B633.
 - b. Galvanized Steel: Hot-dip galvanized after fabrication in accordance with ASTM A123/A123M or ASTM A153/A153M.
- B. Conduit and Cable Supports: Straps, clamps, etc. suitable for the conduit or cable to be supported.
 - 1. Conduit Straps: One-hole or two-hole type; steel or malleable iron.
 - 2. Conduit Clamps: Bolted type unless otherwise indicated.
- C. Outlet Box Supports: Hangers, brackets, etc. suitable for the boxes to be supported.
- D. Metal Channel (Strut) Framing Systems: Factory-fabricated continuous-slot metal channel (strut) and associated fittings, accessories, and hardware required for field-assembly of supports.
 - 1. Comply with MFMA-4.
- E. Hanger Rods: Threaded zinc-plated steel unless otherwise indicated.
- F. Anchors and Fasteners:

1. Unless otherwise indicated and where not otherwise restricted, use the anchor and fastener types indicated for the specified applications.
2. Concrete: Use preset concrete inserts, expansion anchors, or screw anchors.
3. Solid or Grout-Filled Masonry: Use expansion anchors or screw anchors.
4. Hollow Masonry: Use toggle bolts.
5. Hollow Stud Walls: Use toggle bolts.
6. Steel: Use beam clamps, machine bolts, or welded threaded studs.
7. Sheet Metal: Use sheet metal screws.
8. Wood: Use wood screws.
9. Preset Concrete Inserts: Continuous metal channel (strut) and spot inserts specifically designed to be cast in concrete ceilings, walls, and floors.
 - a. Comply with MFMA-4.
 - b. Channel Material: Use galvanized steel.
 - c. Manufacturer: Same as manufacturer of metal channel (strut) framing system.

PART 3 EXECUTION

3.1 INSTALLATION

- A. Install products in accordance with manufacturer's instructions.
- B. Perform work in accordance with NECA 1 (general workmanship).
- C. Provide independent support from building structure. Do not provide support from piping, ductwork, or other systems.
- D. Unless specifically indicated or approved by Architect, do not provide support from suspended ceiling support system or ceiling grid.
- E. Unless specifically indicated or approved by Architect, do not provide support from roof deck.
- F. Do not penetrate or otherwise notch or cut structural members without approval of Structural Engineer.
- G. Equipment Support and Attachment:
 1. Use metal fabricated supports or supports assembled from metal channel (strut) to support equipment as required.
 2. Use metal channel (strut) secured to studs to support equipment surface-mounted on hollow stud walls when wall strength is not sufficient to resist pull-out.
 3. Use metal channel (strut) to support surface-mounted equipment in wet or damp locations to provide space between equipment and mounting surface.
 4. Securely fasten floor-mounted equipment. Do not install equipment such that it relies on its own weight for support.
- H. Preset Concrete Inserts: Use manufacturer provided closure strips to inhibit concrete seepage during concrete pour.
- I. Secure fasteners according to manufacturer's recommended torque settings.
- J. Remove temporary supports.

3.2 FIELD QUALITY CONTROL

- A. Inspect support and attachment components for damage and defects.
- B. Repair cuts and abrasions in galvanized finishes using zinc-rich paint recommended by manufacturer. Replace components that exhibit signs of corrosion.
- C. Correct deficiencies and replace damaged or defective support and attachment components.

END OF SECTION 260529

SECTION 260533.13
CONDUIT FOR ELECTRICAL SYSTEMS

PART 1 GENERAL

1.1 SECTION INCLUDES

- A. Galvanized steel rigid metal conduit (RMC).
- B. Intermediate metal conduit (IMC).
- C. Flexible metal conduit (FMC).
- D. Liquidtight flexible metal conduit (LFMC).
- E. Electrical metallic tubing (EMT).
- F. Rigid polyvinyl chloride (PVC) conduit.
- G. Reinforced thermosetting resin conduit (RTRC).
- H. Conduit fittings.
- I. Accessories.

1.2 RELATED REQUIREMENTS

- A. Section 260519 - Low-Voltage Electrical Power Conductors and Cables: Metal clad cable (Type MC), armored cable (Type AC), and manufactured wiring systems, including uses permitted.
- B. Section 260526 - Grounding and Bonding for Electrical Systems.
- C. Section 260529 - Hangers and Supports for Electrical Systems.
- D. Section 260533.16 - Boxes for Electrical Systems.
- E. Section 260553 - Identification for Electrical Systems: Identification products and requirements.
- F. Section 262100 - Low-Voltage Electrical Service Entrance: Additional requirements for electrical service conduits.
- G. Section 271000 - Structured Cabling: Additional requirements for communications systems conduits.

1.3 REFERENCE STANDARDS

- A. ANSI C80.1 - American National Standard for Electrical Rigid Steel Conduit (ERSC); 2005.
- B. ANSI C80.3 - American National Standard for Steel Electrical Metallic Tubing (EMT); 2005.
- C. ANSI C80.6 - American National Standard for Electrical Intermediate Metal Conduit (EIMC); 2005.
- D. NECA 1 - Standard for Good Workmanship in Electrical Construction; 2010.
- E. NECA 101 - Standard for Installing Steel Conduits (Rigid, IMC, EMT); 2013.
- F. NEMA FB 1 - Fittings, Cast Metal Boxes, and Conduit Bodies for Conduit, Electrical Metallic Tubing, and Cable; 2012.
- G. NEMA TC 2 - Electrical Polyvinyl Chloride (PVC) Conduit; 2013.
- H. NEMA TC 3 - Polyvinyl Chloride (PVC) Fittings for Use with Rigid PVC Conduit and Tubing; 2015.
- I. NEMA TC 14 (SERIES) - Reinforced Thermosetting Resin Conduit and Fittings Series; 2015.
- J. NFPA 70 - National Electrical Code; Most Recent Edition Adopted by Authority Having Jurisdiction, Including All Applicable Amendments and Supplements.
- K. UL 1 - Flexible Metal Conduit; Current Edition, Including All Revisions.
- L. UL 6 - Electrical Rigid Metal Conduit-Steel; Current Edition, Including All Revisions.
- M. UL 360 - Liquid-Tight Flexible Steel Conduit; Current Edition, Including All Revisions.
- N. UL 514B - Conduit, Tubing, and Cable Fittings; Current Edition, Including All Revisions.
- O. UL 651 - Schedule 40, 80, Type EB and A Rigid PVC Conduit and Fittings; Current Edition, Including All Revisions.

- P. UL 797 - Electrical Metallic Tubing-Steel; Current Edition, Including All Revisions.
- Q. UL 1242 - Electrical Intermediate Metal Conduit-Steel; Current Edition, Including All Revisions.

1.4 ADMINISTRATIVE REQUIREMENTS

- A. Coordination:
 - 1. Coordinate minimum sizes of conduits with the actual conductors to be installed, including adjustments for conductor sizes increased for voltage drop.
 - 2. Coordinate the arrangement of conduits with structural members, ductwork, piping, equipment and other potential conflicts installed under other sections or by others.
 - 3. Verify exact conduit termination locations required for boxes, enclosures, and equipment installed under other sections or by others.
 - 4. Coordinate the work with other trades to provide roof penetrations that preserve the integrity of the roofing system and do not void the roof warranty.
 - 5. Notify Architect of any conflicts with or deviations from Contract Documents. Obtain direction before proceeding with work.
- B. Sequencing:
 - 1. Do not begin installation of conductors and cables until installation of conduit is complete between outlet, junction and splicing points.

1.5 SUBMITTALS

- A. Product Data: Provide manufacturer's standard catalog pages and data sheets for conduits and fittings.
- B. Project Record Documents: Record actual routing for conduits installed underground, conduits embedded within concrete slabs, and conduits 2 inch (53 mm) trade size and larger.

1.6 QUALITY ASSURANCE

- A. Comply with requirements of NFPA 70.

1.7 DELIVERY, STORAGE, AND HANDLING

- A. Receive, inspect, handle, and store conduit and fittings in accordance with manufacturer's instructions.

PART 2 PRODUCTS

2.1 CONDUIT APPLICATIONS

- A. Do not use conduit and associated fittings for applications other than as permitted by NFPA 70 and product listing.
- B. Unless otherwise indicated and where not otherwise restricted, use the conduit types indicated for the specified applications. Where more than one listed application applies, comply with the most restrictive requirements. Where conduit type for a particular application is not specified, use galvanized steel rigid metal conduit.
- C. Underground:
 - 1. Under Slab on Grade: Use galvanized steel rigid metal conduit, intermediate metal conduit (IMC), PVC-coated galvanized steel rigid metal conduit, rigid PVC conduit, or reinforced thermosetting resin conduit (RTRC).
 - 2. Exterior, Direct-Buried: Use galvanized steel rigid metal conduit, intermediate metallic conduit (IMC), PVC-coated galvanized steel rigid metal conduit, rigid PVC conduit, or reinforced thermosetting resin conduit (RTRC).
 - 3. Exterior, Embedded Within Concrete: Use galvanized steel rigid metal conduit, intermediate metallic conduit (IMC), PVC-coated galvanized steel rigid metal conduit, rigid PVC conduit, or reinforced thermosetting resin conduit (RTRC).
 - 4. Where rigid polyvinyl (PVC) conduit is provided, transition to galvanized steel rigid metal conduit where emerging from underground.
 - 5. Where rigid polyvinyl (PVC) conduit larger than 2 inch (53 mm) trade size is provided, use galvanized steel rigid metal conduit elbows for bends.
 - 6. Where steel conduit is installed in direct contact with earth where soil has a resistivity of less than 2000 ohm-centimeters or is characterized as severely corrosive based on soils report or local

experience, use corrosion protection tape to provide supplementary corrosion protection or use PVC-coated galvanized steel rigid metal conduit.

7. Where steel conduit emerges from concrete into soil, use corrosion protection tape to provide supplementary corrosion protection for a minimum of 4 inches on either side of where conduit emerges or use PVC-coated galvanized steel rigid metal conduit.

D. Embedded Within Concrete:

1. Within Slab on Grade: Not permitted.
2. Within Slab Above Ground: Not permitted.
3. Within Concrete Walls Above Ground: Use galvanized steel rigid metal conduit, intermediate metal conduit (IMC), PVC-coated galvanized steel rigid metal conduit, rigid PVC conduit, or reinforced thermosetting resin conduit (RTRC).
4. Where rigid polyvinyl (PVC) conduit is provided, transition to galvanized steel rigid metal conduit where emerging from concrete.

E. Concealed Within Masonry Walls: Use galvanized steel rigid metal conduit, intermediate metal conduit (IMC), or electrical metallic tubing (EMT).

F. Concealed Within Hollow Stud Walls: Use galvanized steel rigid metal conduit, intermediate metal conduit (IMC), or electrical metallic tubing (EMT).

G. Concealed Above Accessible Ceilings: Use galvanized steel rigid metal conduit, intermediate metal conduit (IMC), or electrical metallic tubing (EMT).

H. Interior, Damp or Wet Locations: Use galvanized steel rigid metal conduit.

I. Exposed, Interior, Not Subject to Physical Damage: Use galvanized steel rigid metal conduit, intermediate metal conduit (IMC), or electrical metallic tubing (EMT).

J. Exposed, Interior, Subject to Physical Damage: Use galvanized steel rigid metal conduit or intermediate metal conduit (IMC).

1. Locations subject to physical damage include, but are not limited to:
 - a. Where exposed below 8 feet, except within electrical and communication rooms or closets.
 - b. Where exposed below 20 feet in warehouse areas.

K. Exposed, Exterior: Use galvanized steel rigid metal conduit, intermediate metal conduit (IMC), or PVC-coated galvanized steel rigid metal conduit.

L. Concealed, Exterior, Not Embedded in Concrete or in Contact With Earth: Use galvanized steel rigid metal conduit or intermediate metal conduit (IMC).

M. Connections to Luminaires Above Accessible Ceilings: Use flexible metal conduit.

1. Maximum Length: 6 feet.

N. Connections to Vibrating Equipment:

1. Dry Locations: Use flexible metal conduit.
2. Damp, Wet, or Corrosive Locations: Use liquidtight flexible metal conduit.
3. Maximum Length: 6 feet unless otherwise indicated.
4. Vibrating equipment includes, but is not limited to:
 - a. Transformers.
 - b. Motors.

2.2 CONDUIT REQUIREMENTS

A. Electrical Service Conduits: Also comply with Section 262100.

B. Communications Systems Conduits: Also comply with Section 271000.

C. Provide all conduit, fittings, supports, and accessories required for a complete raceway system.

D. Provide products listed, classified, and labeled as suitable for the purpose intended.

E. Minimum Conduit Size, Unless Otherwise Indicated:

1. Branch Circuits: 1/2 inch (16 mm) trade size.
2. Control Circuits: 1/2 inch (16 mm) trade size.

3. Flexible Connections to Luminaires: 1/2 inch (16 mm) trade size.
4. Underground, Interior: 3/4 inch (21 mm) trade size.
5. Underground, Exterior: 1 inch (27 mm) trade size.

F. Where conduit size is not indicated, size to comply with NFPA 70 but not less than applicable minimum size requirements specified.

2.3 GALVANIZED STEEL RIGID METAL CONDUIT (RMC)

A. Manufacturers:

1. Allied Tube & Conduit, a division of Atkore International: www.alliedeg.com/#sle.
2. Nucor Tubular Products: www.nucortubular.com/#sle.
3. Wheatland Tube, a division of Zekelman Industries: www.wheatland.com/#sle.
4. Substitutions: See Section 016000 - Product Requirements.

B. Description: NFPA 70, Type RMC galvanized steel rigid metal conduit complying with ANSI C80.1 and listed and labeled as complying with UL 6.

C. Fittings:

1. Non-Hazardous Locations: Use fittings complying with NEMA FB 1 and listed and labeled as complying with UL 514B.
2. Material: Use steel or malleable iron.
 - a. Do not use die cast zinc fittings.
3. Connectors and Couplings: Use threaded type fittings only. Threadless set screw and compression (gland) type fittings are not permitted.

2.4 INTERMEDIATE METAL CONDUIT (IMC)

A. Manufacturers:

1. Allied Tube & Conduit, a division of Atkore International: www.alliedeg.com/#sle.
2. Nucor Tubular Products: www.nucortubular.com/#sle.
3. Wheatland Tube, a division of Zekelman Industries: www.wheatland.com/#sle.
4. Substitutions: See Section 016000 - Product Requirements.

B. Description: NFPA 70, Type IMC galvanized steel intermediate metal conduit complying with ANSI C80.6 and listed and labeled as complying with UL 1242.

C. Fittings:

1. Non-Hazardous Locations: Use fittings complying with NEMA FB 1 and listed and labeled as complying with UL 514B.
2. Material: Use steel or malleable iron.
 - a. Do not use die cast zinc fittings.
3. Connectors and Couplings: Use threaded type fittings only. Threadless set screw and compression (gland) type fittings are not permitted.

2.5 FLEXIBLE METAL CONDUIT (FMC)

A. Manufacturers:

1. AFC Cable Systems, Inc; _____: www.afcweb.com/#sle.
2. Electri-Flex Company; _____: www.electriflex.com/#sle.
3. International Metal Hose; _____: www.metalhose.com/#sle.
4. Substitutions: See Section 016000 - Product Requirements.

B. Description: NFPA 70, Type FMC standard wall steel or standard wall aluminum flexible metal conduit listed and labeled as complying with UL 1, and listed for use in classified firestop systems to be used.

C. Fittings:

1. Description: Fittings complying with NEMA FB 1 and listed and labeled as complying with UL 514B.
2. Material: Use steel or malleable iron.
 - a. Do not use die cast zinc fittings.

2.6 LIQUIDTIGHT FLEXIBLE METAL CONDUIT (LFMC)

- A. Manufacturers:
 - 1. AFC Cable Systems, Inc; _____ : www.afcweb.com/#sle.
 - 2. Electri-Flex Company; _____ : www.electriflex.com/#sle.
 - 3. International Metal Hose; _____ : www.metalhose.com/#sle.
 - 4. Substitutions: See Section 016000 - Product Requirements.
- B. Description: NFPA 70, Type LFMC polyvinyl chloride (PVC) jacketed steel or aluminum flexible metal conduit listed and labeled as complying with UL 360.
- C. Fittings:
 - 1. Description: Fittings complying with NEMA FB 1 and listed and labeled as complying with UL 514B.
 - 2. Material: Use steel or malleable iron.
 - a. Do not use die cast zinc fittings.

2.7 ELECTRICAL METALLIC TUBING (EMT)

- A. Manufacturers:
 - 1. Allied Tube & Conduit, a division of Atkore International: www.alliedeg.com/#sle.
 - 2. Nucor Tubular Products: www.nucortubular/#sle.
 - 3. Wheatland Tube, a division of Zekelman Industries: www.wheatland.com/#sle.
 - 4. Substitutions: See Section 016000 - Product Requirements.
- B. Description: NFPA 70, Type EMT steel electrical metallic tubing complying with ANSI C80.3 and listed and labeled as complying with UL 797.
- C. Fittings:
 - 1. Description: Fittings complying with NEMA FB 1 and listed and labeled as complying with UL 514B.
 - 2. Material: Use steel or malleable iron.
 - a. Do not use die cast zinc fittings.
 - 3. Connectors and Couplings: Use compression (gland) or set-screw type.
 - a. Do not use indenter type connectors and couplings.

2.8 RIGID POLYVINYL CHLORIDE (PVC) CONDUIT

- A. Manufacturers:
 - 1. Cantex Inc: www.cantexinc.com/#sle.
 - 2. Carlon, a brand of Thomas & Betts Corporation: www.carlon.com/#sle.
 - 3. JM Eagle: www.jmeagle.com/#sle.
 - 4. Substitutions: See Section 016000 - Product Requirements.
- B. Description: NFPA 70, Type PVC rigid polyvinyl chloride conduit complying with NEMA TC 2 and listed and labeled as complying with UL 651; Schedule 40 unless otherwise indicated, Schedule 80 where subject to physical damage; rated for use with conductors rated 90 degrees C.
- C. Fittings:
 - 1. Manufacturer: Same as manufacturer of conduit to be connected.
 - 2. Description: Fittings complying with NEMA TC 3 and listed and labeled as complying with UL 651; material to match conduit.

2.9 REINFORCED THERMOSETTING RESIN CONDUIT (RTRC)

- A. Description: NFPA 70, Type RTRC reinforced thermosetting resin conduit complying with NEMA TC 14 (SERIES).
- B. Supports: Per manufacturer's recommendations.
- C. Fittings: Same type and manufacturer as conduit to be connected.

2.10 ACCESSORIES

- A. Corrosion Protection Tape: PVC-based, minimum thickness of 20 mil.

- B. Conduit Joint Compound: Corrosion-resistant, electrically conductive; suitable for use with the conduit to be installed.
- C. Solvent Cement for PVC Conduit and Fittings: As recommended by manufacturer of conduit and fittings to be installed.
- D. Epoxy Adhesive for RTRC Conduit and Fittings: As recommended by manufacturer of conduit and fittings to be installed.
- E. Pull Strings: Use nylon cord with average breaking strength of not less than 200 pound-force.
- F. Sealing Compound for Sealing Fittings: Listed for use with the particular fittings to be installed.

PART 3 EXECUTION

3.1 EXAMINATION

- A. Verify that field measurements are as indicated.
- B. Verify that mounting surfaces are ready to receive conduits.
- C. Verify that conditions are satisfactory for installation prior to starting work.

3.2 INSTALLATION

- A. Install products in accordance with manufacturer's instructions.
- B. Perform work in accordance with NECA 1 (general workmanship).
- C. Install galvanized steel rigid metal conduit (RMC) in accordance with NECA 101.
- D. Install intermediate metal conduit (IMC) in accordance with NECA 101.
- E. Install rigid polyvinyl chloride (PVC) conduit in accordance with NECA 111.
- F. Conduit Routing:
 - 1. Unless dimensioned, conduit routing indicated is diagrammatic.
 - 2. When conduit destination is indicated without specific routing, determine exact routing required.
 - 3. Conceal all conduits unless specifically indicated to be exposed.
 - 4. Conduits in the following areas may be exposed, unless otherwise indicated:
 - a. Electrical rooms.
 - b. Mechanical equipment rooms.
 - c. Within joists in areas with no ceiling.
 - 5. Unless otherwise approved, do not route conduits exposed:
 - a. Across floors.
 - b. Across roofs.
 - c. Across top of parapet walls.
 - d. Across building exterior surfaces.
 - 6. Conduits installed underground or embedded in concrete may be routed in the shortest possible manner unless otherwise indicated. Route all other conduits parallel or perpendicular to building structure and surfaces, following surface contours where practical.
 - 7. Arrange conduit to maintain adequate headroom, clearances, and access.
 - 8. Arrange conduit to provide no more than the equivalent of four 90 degree bends between pull points.
 - 9. Route conduits above water and drain piping where possible.
 - 10. Arrange conduit to prevent moisture traps. Provide drain fittings at low points and at sealing fittings where moisture may collect.
 - 11. Maintain minimum clearance of 6 inches between conduits and piping for other systems.
 - 12. Maintain minimum clearance of 12 inches between conduits and hot surfaces. This includes, but is not limited to:
 - a. Heaters.
 - b. Hot water piping.
 - c. Flues.
 - 13. Group parallel conduits in the same area together on a common rack.

G. Conduit Support:

1. Secure and support conduits in accordance with NFPA 70 and Section 260529 using suitable supports and methods approved by the authority having jurisdiction.
2. Provide independent support from building structure. Do not provide support from piping, ductwork, or other systems.
3. Installation Above Suspended Ceilings: Do not provide support from ceiling support system. Do not provide support from ceiling grid or allow conduits to lay on ceiling tiles.
4. Use conduit strap to support single surface-mounted conduit.
 - a. Use clamp back spacer with conduit strap for damp and wet locations to provide space between conduit and mounting surface.
5. Use metal channel (strut) with accessory conduit clamps to support multiple parallel surface-mounted conduits.
6. Use conduit clamp to support single conduit from beam clamp or threaded rod.
7. Use trapeze hangers assembled from threaded rods and metal channel (strut) with accessory conduit clamps to support multiple parallel suspended conduits.

H. Connections and Terminations:

1. Use approved zinc-rich paint or conduit joint compound on field-cut threads of galvanized steel conduits prior to making connections.
2. Where two threaded conduits must be joined and neither can be rotated, use three-piece couplings or split couplings. Do not use running threads.
3. Use suitable adapters where required to transition from one type of conduit to another.
4. Provide drip loops for liquidtight flexible conduit connections to prevent drainage of liquid into connectors.
5. Terminate threaded conduits in boxes and enclosures using threaded hubs or double lock nuts for dry locations and raintight hubs for wet locations.
6. Where spare conduits stub up through concrete floors and are not terminated in a box or enclosure, provide threaded couplings equipped with threaded plugs set flush with finished floor.
7. Provide insulating bushings or insulated throats at all conduit terminations to protect conductors.
8. Secure joints and connections to provide maximum mechanical strength and electrical continuity.

I. Penetrations:

1. Do not penetrate or otherwise notch or cut structural members, including footings and grade beams, without approval of Structural Engineer.
2. Make penetrations perpendicular to surfaces unless otherwise indicated.
3. Provide sleeves for penetrations as indicated or as required to facilitate installation. Set sleeves flush with exposed surfaces unless otherwise indicated or required.
4. Conceal bends for conduit risers emerging above ground.
5. Seal interior of conduits entering the building from underground at first accessible point to prevent entry of moisture and gases.
6. Where conduits penetrate waterproof membrane, seal as required to maintain integrity of membrane.
7. Make penetrations for roof-mounted equipment within associated equipment openings and curbs where possible to minimize roofing system penetrations. Where penetrations are necessary, seal as indicated or as required to preserve integrity of roofing system and maintain roof warranty. Include proposed locations of penetrations and methods for sealing with submittals.
8. Install firestopping to preserve fire resistance rating of partitions and other elements, using materials and methods specified in Section 078400.

J. Underground Installation:

1. Provide trenching and backfilling in accordance with specifications.
2. Minimum Cover, Unless Otherwise Indicated or Required:
 - a. Underground, Exterior: 24 inches.
 - b. Under Slab on Grade: 12 inches to bottom of slab.

3. Provide underground warning tape in accordance with Section 260553 along entire conduit length for service entrance where not concrete-encased.
 - K. Concrete Encasement: Where conduits not otherwise embedded within concrete are indicated to be concrete-encased, provide concrete in accordance with Section 033000 with minimum concrete cover of 3 inches on all sides unless otherwise indicated.
 - L. Conduit Movement Provisions: Where conduits are subject to movement, provide expansion and expansion/deflection fittings to prevent damage to enclosed conductors or connected equipment. This includes, but is not limited to:
 1. Where conduits cross structural joints intended for expansion, contraction, or deflection.
 2. Where calculated in accordance with NFPA 70 for reinforced thermosetting resin conduit (RTRC) conduit installed above ground to compensate for thermal expansion and contraction.
 3. Where conduits are subject to earth movement by settlement or frost.
 - M. Condensation Prevention: Where conduits cross barriers between areas of potential substantial temperature differential, provide sealing fitting or approved sealing compound at an accessible point near the penetration to prevent condensation. This includes, but is not limited to:
 1. Where conduits pass from outdoors into conditioned interior spaces.
 2. Where conduits pass from unconditioned interior spaces into conditioned interior spaces.
 - N. Provide pull string in all empty conduits and in conduits where conductors and cables are to be installed by others. Leave minimum slack of 12 inches at each end.
 - O. Provide grounding and bonding in accordance with Section 260526.
 - P. Identify conduits in accordance with Section 260553.
- 3.3 FIELD QUALITY CONTROL
- A. See Section 014000 - Quality Requirements, for additional requirements.
 - B. Repair cuts and abrasions in galvanized finishes using zinc-rich paint recommended by manufacturer. Replace components that exhibit signs of corrosion.
 - C. Correct deficiencies and replace damaged or defective conduits.
- 3.4 CLEANING
- A. Clean interior of conduits to remove moisture and foreign matter.
- 3.5 PROTECTION
- A. Immediately after installation of conduit, use suitable manufactured plugs to provide protection from entry of moisture and foreign material and do not remove until ready for installation of conductors.

END OF SECTION 260533.13

SECTION 260533.16
BOXES FOR ELECTRICAL SYSTEMS

PART 1 GENERAL

1.1 SECTION INCLUDES

- A. Outlet and device boxes up to 100 cubic inches, including those used as junction and pull boxes.
- B. Cabinets and enclosures, including junction and pull boxes larger than 100 cubic inches.
- C. Pull and junction boxes.

1.2 RELATED REQUIREMENTS

- A. Section 083100 - Access Doors and Panels: Panels for maintaining access to concealed boxes.
- B. Section 260529 - Hangers and Supports for Electrical Systems.
- C. Section 260553 - Identification for Electrical Systems: Identification products and requirements.
- D. Section 262726 - Wiring Devices:
 - 1. Wall plates.
- E. Section 262716 - Electrical Cabinets and Enclosures.
- F. Section 262726 - Wiring Devices: Wall plates in finished areas.

1.3 REFERENCE STANDARDS

- A. NECA 1 - Standard for Good Workmanship in Electrical Construction; 2010.
- B. NECA 130 - Standard for Installing and Maintaining Wiring Devices; 2010.
- C. NEMA FB 1 - Fittings, Cast Metal Boxes, and Conduit Bodies for Conduit, Electrical Metallic Tubing, and Cable; 2012.
- D. NEMA OS 1 - Sheet-Steel Outlet Boxes, Device Boxes, Covers, and Box Supports; 2013.
- E. NEMA 250 - Enclosures for Electrical Equipment (1000 Volts Maximum); 2014.
- F. NFPA 70 - National Electrical Code; Most Recent Edition Adopted by Authority Having Jurisdiction, Including All Applicable Amendments and Supplements.
- G. UL 50 - Enclosures for Electrical Equipment, Non-Environmental Considerations; Current Edition, Including All Revisions.
- H. UL 50E - Enclosures for Electrical Equipment, Environmental Considerations; Current Edition, Including All Revisions.
- I. UL 508A - Industrial Control Panels; Current Edition, Including All Revisions.
- J. UL 514A - Metallic Outlet Boxes; Current Edition, Including All Revisions.
- K. UL 514C - Nonmetallic Outlet Boxes, Flush-Device Boxes, and Covers; Current Edition, Including All Revisions.

1.4 ADMINISTRATIVE REQUIREMENTS

- A. Coordination:
 - 1. Coordinate the work with other trades to avoid placement of ductwork, piping, equipment, or other potential obstructions within the dedicated equipment spaces and working clearances for electrical equipment required by NFPA 70.
 - 2. Coordinate arrangement of electrical equipment with the dimensions and clearance requirements of the actual equipment to be installed.
 - 3. Coordinate minimum sizes of boxes with the actual installed arrangement of conductors, clamps, support fittings, and devices, calculated according to NFPA 70.
 - 4. Coordinate minimum sizes of pull boxes with the actual installed arrangement of connected conduits, calculated according to NFPA 70.
 - 5. Coordinate the placement of boxes with millwork, furniture, devices, equipment, etc. installed under other sections or by others.

6. Coordinate the work with other trades to preserve insulation integrity.
7. Coordinate the work with other trades to provide walls suitable for installation of flush-mounted boxes where indicated.
8. Notify Architect of any conflicts with or deviations from Contract Documents. Obtain direction before proceeding with work.

1.5 SUBMITTALS

- A. See Section 013000 - Administrative Requirements, for submittal procedures.
- B. Project Record Documents: Record actual locations and mounting heights of outlet, pull, and junction boxes on project record documents.

1.6 QUALITY ASSURANCE

- A. Comply with requirements of NFPA 70.

PART 2 PRODUCTS

2.1 BOXES

- A. General Requirements:
 1. Do not use boxes and associated accessories for applications other than as permitted by NFPA 70 and product listing.
 2. Provide all boxes, fittings, supports, and accessories required for a complete raceway system and to accommodate devices and equipment to be installed.
 3. Provide products listed, classified, and labeled as suitable for the purpose intended.
 4. Where box size is not indicated, size to comply with NFPA 70 but not less than applicable minimum size requirements specified.
 5. Provide grounding terminals within boxes where equipment grounding conductors terminate.
- B. Outlet and Device Boxes Up to 100 cubic inches, Including Those Used as Junction and Pull Boxes:
 1. Use sheet-steel boxes for dry locations unless otherwise indicated or required.
 2. Use cast iron boxes or cast aluminum boxes for damp or wet locations unless otherwise indicated or required; furnish with compatible weatherproof gasketed covers.
 3. Use suitable concrete type boxes where flush-mounted in concrete.
 4. Use suitable masonry type boxes where flush-mounted in masonry walls.
 5. Use raised covers suitable for the type of wall construction and device configuration where required.
 6. Use shallow boxes where required by the type of wall construction.
 7. Do not use "through-wall" boxes designed for access from both sides of wall.
 8. Sheet-Steel Boxes: Comply with NEMA OS 1, and list and label as complying with UL 514A.
 9. Cast Metal Boxes: Comply with NEMA FB 1, and list and label as complying with UL 514A; furnish with threaded hubs.
 10. Nonmetallic Boxes: Comply with NEMA OS 2, and list and label as complying with UL 514C.
 11. Boxes for Supporting Luminaires and Ceiling Fans: Listed as suitable for the type and weight of load to be supported; furnished with fixture stud to accommodate mounting of luminaire where required.
 12. Boxes for Ganged Devices: Use multigang boxes of single-piece construction. Do not use field-connected gangable boxes unless specifically indicated or permitted.
 13. Wall Plates: Comply with Section 262726.
- C. Cabinets and Enclosures, Including Junction and Pull Boxes Larger Than 100 cubic inches:
 1. Comply with NEMA 250, and list and label as complying with UL 50 and UL 50E, or UL 508A.
 2. NEMA 250 Environment Type, Unless Otherwise Indicated:
 3. Junction and Pull Boxes Larger Than 100 cubic inches:
 - a. Provide screw-cover or hinged-cover enclosures unless otherwise indicated.
 4. Finish for Painted Steel Enclosures: Manufacturer's standard grey unless otherwise indicated.

PART 3 EXECUTION

3.1 EXAMINATION

- A. Verify that field measurements are as indicated.
- B. Verify that mounting surfaces are ready to receive boxes.
- C. Verify that conditions are satisfactory for installation prior to starting work.
- D. Verify locations of outlets in offices and work areas prior to rough-in.

3.2 INSTALLATION

- A. Install products in accordance with manufacturer's instructions.
- B. Install boxes in accordance with NECA 1 (general workmanship) and, where applicable, NECA 130, including mounting heights specified in those standards where mounting heights are not indicated.
- C. Arrange equipment to provide minimum clearances in accordance with manufacturer's instructions and NFPA 70.
- D. Flush-mount boxes in finished areas unless specifically indicated to be surface-mounted.
- E. Box Locations:
 - 1. Locate boxes to be accessible. Provide access panels in accordance with Section 083100 as required where approved by the Architect.
 - 2. Unless dimensioned, box locations indicated are approximate.
 - 3. Locate boxes as required for devices installed under other sections or by others.
 - 4. Locate boxes so that wall plates do not span different building finishes.
 - 5. Locate boxes so that wall plates do not cross masonry joints.
- F. Box Supports:
 - 1. Secure and support boxes in accordance with NFPA 70 and Section 260529 using suitable supports and methods approved by the authority having jurisdiction.
 - 2. Provide independent support from building structure except for cast metal boxes (other than boxes used for fixture support) supported by threaded conduit connections in accordance with NFPA 70. Do not provide support from piping, ductwork, or other systems.
- G. Install boxes plumb and level.
- H. Flush-Mounted Boxes:
 - 1. Install boxes in noncombustible materials such as concrete, tile, gypsum, plaster, etc. so that front edge of box or associated raised cover is not set back from finished surface more than 1/4 inch or does not project beyond finished surface.
 - 2. Install boxes in combustible materials such as wood so that front edge of box or associated raised cover is flush with finished surface.
 - 3. Repair rough openings around boxes in noncombustible materials such as concrete, tile, gypsum, plaster, etc. so that there are no gaps or open spaces greater than 1/8 inch at the edge of the box.
- I. Install boxes as required to preserve insulation integrity.
- J. Install permanent barrier between ganged wiring devices when voltage between adjacent devices exceeds 300 V.
- K. Install firestopping to preserve fire resistance rating of partitions and other elements, using materials and methods specified in Section 078400.
- L. Close unused box openings.
- M. Install blank wall plates on junction boxes and on outlet boxes with no devices or equipment installed or designated for future use.
- N. Provide grounding and bonding in accordance with Section 260526.
- O. Install boxes securely, in a neat and workmanlike manner, as specified in NECA 1.
- P. Install in locations as shown on Drawings, and as required for splices, taps, wire pulling, equipment connections, and as required by NFPA 70.

- Q. Coordinate installation of outlet boxes for equipment connected under Section 262717.
 - R. Set wall mounted boxes at elevations to accommodate mounting heights indicated.
 - S. Electrical boxes are shown on Drawings in approximate locations unless dimensioned.
 - 1. Adjust box locations up to 10 feet if required to accommodate intended purpose.
 - T. Orient boxes to accommodate wiring devices oriented as specified in Section 262726.
 - U. Maintain headroom and present neat mechanical appearance.
 - V. Install pull boxes and junction boxes above accessible ceilings and in unfinished areas only.
 - W. Inaccessible Ceiling Areas: Install outlet and junction boxes no more than 6 inches from ceiling access panel or from removable recessed luminaire.
 - X. Coordinate mounting heights and locations of outlets mounted above counters, benches, and backsplashes.
 - Y. Locate outlet boxes to allow luminaires positioned as shown on reflected ceiling plan.
 - Z. Align adjacent wall mounted outlet boxes for switches, thermostats, and similar devices.
 - AA. Use flush mounting outlet box in finished areas.
 - AB. Locate flush mounting box in masonry wall to require cutting of masonry unit corner only. Coordinate masonry cutting to achieve neat opening.
 - AC. Unless otherwise indicated, provide separate boxes for line voltage and low voltage systems.
 - AD. Locate outlet boxes so that wall plates do not span different building finishes.
 - AE. Do not install flush mounting box back-to-back in walls; provide minimum 6 inches separation.
 - AF. Secure flush mounting box to interior wall and partition studs. Accurately position to allow for surface finish thickness.
 - AG. Use stamped steel bridges to fasten flush mounting outlet box between studs.
 - AH. Install flush mounting box without damaging wall insulation or reducing its effectiveness.
 - AI. Use adjustable steel channel fasteners for hung ceiling outlet box.
 - AJ. Do not fasten boxes to ceiling support wires.
 - AK. Support boxes independently of conduit, except cast box that is connected to two rigid metal conduits both supported within 12 inches of box.
 - AL. Use gang box where more than one device is mounted together. Do not use sectional box.
 - AM. Use gang box with plaster ring for single device outlets.
 - AN. Use cast outlet box in exterior locations exposed to the weather and wet locations.
 - AO. Large Pull Boxes: Use hinged enclosure in interior dry locations, surface-mounted cast metal box in other locations.
 - AP. Identify boxes in accordance with Section 260553.
- 3.3 ADJUSTING
- A. Adjust flush-mounting outlets to make front flush with finished wall material.
 - B. Install knockout closures in unused box openings.
- 3.4 CLEANING
- A. Clean interior of boxes to remove dirt, debris, plaster and other foreign material.

END OF SECTION 260533.16

SECTION 260553
IDENTIFICATION FOR ELECTRICAL SYSTEMS

PART 1 GENERAL

1.1 SECTION INCLUDES

- A. Electrical identification requirements.
- B. Identification nameplates and labels.
- C. Wire and cable markers.
- D. Underground warning tape.
- E. Warning signs and labels.

1.2 RELATED REQUIREMENTS

- A. Section 099113 - Exterior Painting.
- B. Section 260519 - Low-Voltage Electrical Power Conductors and Cables: Color coding for power conductors and cables 600 V and less; vinyl color coding electrical tape.
- C. Section 262726 - Wiring Devices - Lutron: Device and wallplate finishes; factory pre-marked wallplates.

1.3 REFERENCE STANDARDS

- A. NFPA 70 - National Electrical Code; Most Recent Edition Adopted by Authority Having Jurisdiction, Including All Applicable Amendments and Supplements.
- B. UL 969 - Marking and Labeling Systems; Current Edition, Including All Revisions.

1.4 ADMINISTRATIVE REQUIREMENTS

- A. Coordination:
 - 1. Verify final designations for equipment, systems, and components to be identified prior to fabrication of identification products.
- B. Sequencing:
 - 1. Do not conceal items to be identified, in locations such as above suspended ceilings, until identification products have been installed.
 - 2. Do not install identification products until final surface finishes and painting are complete.

1.5 QUALITY ASSURANCE

- A. Comply with requirements of NFPA 70.

1.6 FIELD CONDITIONS

- A. Do not install adhesive products when ambient temperature is lower than recommended by manufacturer.

PART 2 PRODUCTS

2.1 IDENTIFICATION REQUIREMENTS

- A. Identification for Equipment:
 - 1. Use identification nameplate to identify each piece of electrical distribution and control equipment and associated sections, compartments, and components.
 - a. Switchboards:
 - 1) Identify voltage and phase.
 - 2) Use identification nameplate to identify main overcurrent protective device.
 - 3) Use identification nameplate to identify load(s) served for each branch device.
 - b. Panelboards:
 - 1) Identify ampere rating.
 - 2) Identify voltage and phase.
 - 3) Use typewritten circuit directory to identify load(s) served for panelboards with a door. Identify spares and spaces using pencil.
 - 4) For power panelboards without a door, use identification nameplate to identify load(s) served for each branch device. Do not identify spares and spaces.

- c. Enclosed switches, circuit breakers, and motor controllers:
 - 1) Identify voltage and phase.
 - 2) Identify load(s) served. Include location when not within sight of equipment.
 - d. Enclosed Contactors:
 - 1) Identify coil voltage.
 - 2) Identify load(s) and associated circuits controlled. Include location.
 - 2. Service Equipment:
 - a. Use identification nameplate to identify each service disconnecting means.
 - 3. Use identification label or handwritten text using indelible marker on inside of door at each fused switch to identify required NEMA fuse class and size.
 - 4. Use field-painted floor markings, floor marking tape, or warning labels to identify required equipment working clearances where indicated or where required by the authority having jurisdiction.
 - 5. Available Fault Current Documentation: Use identification label to identify the available fault current and date calculations were performed at locations requiring documentation by NFPA 70, including but not limited to the following.
 - a. Service equipment.
 - b. Industrial control panels.
 - c. Motor control centers.
 - d. Elevator control panels.
 - e. Industrial machinery.
 - 6. Arc Flash Hazard Warning Labels: Use warning labels to identify arc flash hazards for switchboards and panelboards.
 - a. Legend: Include orange header that reads "WARNING", followed by the word message "Arc Flash and Shock Hazard; Appropriate PPE Required; Do not operate controls or open covers without appropriate personal protection equipment; Failure to comply may result in injury or death; Refer to NFPA 70E for minimum PPE requirements" or approved equivalent.
- B. Identification for Conductors and Cables:
 - 1. Color Coding for Power Conductors 600 V and Less: Comply with Section 260519.
 - 2. Identification for Communications Conductors and Cables: Comply with Section 271000.
 - 3. Use identification nameplate or identification label to identify color code for ungrounded and grounded power conductors inside door or enclosure at each piece of feeder or branch-circuit distribution equipment.
- C. Identification for Raceways:
 - 1. Use identification labels or plastic marker tags to identify spare conduits at each end. Identify purpose and termination location.
 - 2. Use underground warning tape to identify underground raceways.
- D. Identification for Boxes:
 - 1. Use color coded boxes to identify systems other than normal power system.
 - a. Color-Coded Boxes: Field-painted in accordance with Section 099123 and 099113 per the same color code used for raceways.
 - 1) Fire Alarm System: Red.
- E. Identification for Devices:
 - 1. Identification for Communications Devices: Comply with Section 271000.
 - 2. Wiring Device and Wallplate Finishes: Comply with Section 262726.
 - 3. Use identification label or engraved wallplate to identify load controlled for wall-mounted control devices controlling loads that are not visible from the control location and for multiple wall-mounted control devices installed at one location.
 - 4. Use identification label to identify receptacles protected by upstream GFI protection, where permitted.

2.2 IDENTIFICATION NAMEPLATES AND LABELS

A. Identification Nameplates:

1. Materials:
 - a. Indoor Clean, Dry Locations: Use plastic nameplates.
 - b. Outdoor Locations: Use plastic, stainless steel, or aluminum nameplates suitable for exterior use.
 2. Plastic Nameplates: Two-layer or three-layer laminated acrylic or electrically non-conductive phenolic with beveled edges; minimum thickness of 1/16 inch; engraved text.
 - a. Exception: Provide minimum thickness of 1/8 inch when any dimension is greater than 4 inches.
 3. Stainless Steel Nameplates: Minimum thickness of 1/32 inch; engraved or laser-etched text.
 4. Aluminum Nameplates: Anodized; minimum thickness of 1/32 inch; engraved or laser-etched text.
 5. Mounting Holes for Mechanical Fasteners: Two, centered on sides for sizes up to 1 inch high; Four, located at corners for larger sizes.
- B. Identification Labels:
1. Manufacturers:
 2. Materials: Use self-adhesive laminated plastic labels; UV, chemical, water, heat, and abrasion resistant.
 - a. Use only for indoor locations.
 3. Text: Use factory pre-printed or machine-printed text. Do not use handwritten text unless otherwise indicated.
- C. Format for Equipment Identification:
1. Minimum Size: 1 inch by 2.5 inches.
 2. Legend:
 - a. Equipment designation or other approved description.
 - b. Other information as indicated.
 3. Text: All capitalized unless otherwise indicated.
 4. Minimum Text Height:
 - a. Equipment Designation: 1/2 inch.
 - b. Other Information: 1/4 inch.
 5. Color:
 - a. Normal Power System: White text on black background.
 - b. Fire Alarm System: White text on red background.
- D. Format for General Information and Operating Instructions:
1. Minimum Size: 1 inch by 2.5 inches.
 2. Legend: Include information or instructions indicated or as required for proper and safe operation and maintenance.
 3. Text: All capitalized unless otherwise indicated.
 4. Minimum Text Height: 1/4 inch.
 5. Color: Black text on white background unless otherwise indicated.
 - a. Exceptions:
 - 1) Provide white text on red background for general information or operational instructions for fire alarm systems.
- E. Format for Caution and Warning Messages:
1. Minimum Size: 2 inches by 4 inches.
 2. Legend: Include information or instructions indicated or as required for proper and safe operation and maintenance.
 3. Text: All capitalized unless otherwise indicated.
 4. Minimum Text Height: 1/2 inch.
 5. Color: Black text on yellow background unless otherwise indicated.
- F. Format for Control Device Identification:
1. Minimum Size: 3/8 inch by 1.5 inches.
 2. Legend: Load controlled or other designation indicated.
 3. Text: All capitalized unless otherwise indicated.

4. Minimum Text Height: 3/16 inch.
5. Color: Black text on clear background.

2.3 WIRE AND CABLE MARKERS

- A. Markers for Conductors and Cables: Use wrap-around self-adhesive vinyl cloth, wrap-around self-adhesive vinyl self-laminating, heat-shrink sleeve, plastic sleeve, plastic clip-on, or vinyl split sleeve type markers suitable for the conductor or cable to be identified.
- B. Markers for Conductor and Cable Bundles: Use plastic marker tags secured by nylon cable ties.
- C. Legend: Power source and circuit number or other designation indicated.
- D. Text: Use factory pre-printed or machine-printed text, all capitalized unless otherwise indicated.
 1. Do not use handwritten text.
- E. Minimum Text Height: 1/8 inch.
- F. Color: Black text on white background unless otherwise indicated.

2.4 UNDERGROUND WARNING TAPE

- A. Materials: Use non-detectable type polyethylene tape suitable for direct burial, unless otherwise indicated.
 1. Exception: Use foil-backed detectable type tape where required by serving utility.
- B. Non-detectable Type Tape: 3 inches wide, with minimum thickness of 4 mil.
- C. Foil-backed Detectable Type Tape: 3 inches wide, with minimum thickness of 5 mil, unless otherwise required for proper detection.
- D. Legend: Type of service, continuously repeated over full length of tape.
- E. Color:
 1. Tape for Buried Power Lines: Black text on red background.
 2. Tape for Buried Communication, Alarm, and Signal Lines: Black text on orange background.

2.5 WARNING SIGNS AND LABELS

- A. Comply with ANSI Z535.2 or ANSI Z535.4 as applicable.
- B. Warning Signs:
 1. Materials:
 - a. Indoor Dry, Clean Locations: Use factory pre-printed rigid plastic or self-adhesive vinyl signs.
 - b. Outdoor Locations: Use factory pre-printed rigid aluminum signs.
 2. Rigid Signs: Provide four mounting holes at corners for mechanical fasteners.
 3. Minimum Size: 7 by 10 inches unless otherwise indicated.
- C. Warning Labels:
 1. Materials: Use factory pre-printed or machine-printed self-adhesive polyester or self-adhesive vinyl labels; UV, chemical, water, heat, and abrasion resistant; produced using materials recognized to UL 969.
 2. Machine-Printed Labels: Use thermal transfer process printing machines and accessories recommended by label manufacturer.
 3. Minimum Size: 2 by 4 inches unless otherwise indicated.

PART 3 EXECUTION

3.1 PREPARATION

- A. Clean surfaces to receive adhesive products according to manufacturer's instructions.

3.2 INSTALLATION

- A. Install products in accordance with manufacturer's instructions.
- B. Install identification products to be plainly visible for examination, adjustment, servicing, and maintenance. Unless otherwise indicated, locate products as follows:
 1. Surface-Mounted Equipment: Enclosure front.

2. Flush-Mounted Equipment: Enclosure front.
 3. Free-Standing Equipment: Enclosure front; also enclosure rear for equipment with rear access.
 4. Elevated Equipment: Legible from the floor or working platform.
 5. Branch Devices: Adjacent to device.
 6. Interior Components: Legible from the point of access.
 7. Conduits: Legible from the floor.
 8. Boxes: Outside face of cover.
 9. Conductors and Cables: Legible from the point of access.
 10. Devices: Outside face of cover.
- C. Install identification products centered, level, and parallel with lines of item being identified.
 - D. Secure nameplates to exterior surfaces of enclosures using stainless steel screws and to interior surfaces using self-adhesive backing or epoxy cement.
 1. Do not use adhesives on exterior surfaces except where substrate cannot be penetrated.
 - E. Install self-adhesive labels and markers to achieve maximum adhesion, with no bubbles or wrinkles and edges properly sealed.
 - F. Install underground warning tape above buried lines with one tape per trench at 12 inch(es) below finished grade.
 - G. Secure rigid signs using stainless steel screws.
 - H. Mark all handwritten text, where permitted, to be neat and legible.
- 3.3 FIELD QUALITY CONTROL
- A. See Section 014000 - Quality Requirements, for additional requirements.
 - B. Replace self-adhesive labels and markers that exhibit bubbles, wrinkles, curling or other signs of improper adhesion.

END OF SECTION 260553

SECTION 260583
WIRING CONNECTIONS

PART 1 GENERAL

1.1 SECTION INCLUDES

- A. Electrical connections to equipment.

1.2 RELATED REQUIREMENTS

- A. Section 260519 - Low-Voltage Electrical Power Conductors and Cables.
- B. Section 260533.13 - Conduit for Electrical Systems.
- C. Section 260519 - Low-Voltage Electrical Power Conductors and Cables (600 V and Less).
- D. Section 260533.16 - Boxes for Electrical Systems.
- E. Section 262726 - Wiring Devices.
- F. Section 262816.16 - Enclosed Switches.

1.3 REFERENCE STANDARDS

- A. NEMA WD 1 - General Color Requirements for Wiring Devices; 1999 (R 2010).
- B. NEMA WD 6 - Wiring Devices - Dimensional Specifications; 2012.
- C. NFPA 70 - National Electrical Code; Most Recent Edition Adopted by Authority Having Jurisdiction, Including All Applicable Amendments and Supplements.

1.4 ADMINISTRATIVE REQUIREMENTS

- A. Coordination:
 - 1. Obtain and review shop drawings, product data, manufacturer's wiring diagrams, and manufacturer's instructions for equipment furnished under other sections.
 - 2. Determine connection locations and requirements.
- B. Sequencing:
 - 1. Install rough-in of electrical connections before installation of equipment is required.
 - 2. Make electrical connections before required start-up of equipment.

1.5 SUBMITTALS

- A. See Section 013000 - Administrative Requirements, for submittal procedures.
- B. Product Data: Provide wiring device manufacturer's catalog information showing dimensions, configurations, and construction.

1.6 QUALITY ASSURANCE

- A. Comply with requirements of NFPA 70.
- B. Products: Listed, classified, and labeled as suitable for the purpose intended.

PART 2 PRODUCTS

2.1 MATERIALS

- A. Cords and Caps: NEMA WD 6; match receptacle configuration at outlet provided for equipment.
 - 1. Colors: Comply with NEMA WD 1.
 - 2. Cord Construction: NFPA 70, Type SO, multiconductor flexible cord with identified equipment grounding conductor, suitable for use in damp locations.
 - 3. Size: Suitable for connected load of equipment, length of cord, and rating of branch circuit overcurrent protection.
- B. Disconnect Switches: As specified in Section 262816.16 and in individual equipment sections.
- C. Wiring Devices: As specified in Section 262726.
- D. Flexible Conduit: As specified in Section 260533.13.
- E. Wire and Cable: As specified in Section 260519.

- F. Boxes: As specified in Section 260533.16.

PART 3 EXECUTION

3.1 EXAMINATION

- A. Verify that equipment is ready for electrical connection, wiring, and energization.

3.2 ELECTRICAL CONNECTIONS

- A. Make electrical connections in accordance with equipment manufacturer's instructions.
- B. Make conduit connections to equipment using flexible metal conduit. Use liquidtight flexible metal conduit with watertight connectors in damp or wet locations.
- C. Connect heat producing equipment using wire and cable with insulation suitable for temperatures encountered.
- D. Provide receptacle outlet to accommodate connection with attachment plug.
- E. Provide cord and cap where field-supplied attachment plug is required.
- F. Install suitable strain-relief clamps and fittings for cord connections at outlet boxes and equipment connection boxes.
- G. Install disconnect switches, controllers, control stations, and control devices to complete equipment wiring requirements.
- H. Install terminal block jumpers to complete equipment wiring requirements.
- I. Install interconnecting conduit and wiring between devices and equipment to complete equipment wiring requirements.

END OF SECTION 260583

SECTION 262100
LOW-VOLTAGE ELECTRICAL SERVICE ENTRANCE

PART 1 GENERAL

1.1 SECTION INCLUDES

- A. Electrical service requirements.

1.2 RELATED REQUIREMENTS

- A. Section 260519 - Low-Voltage Electrical Power Conductors and Cables.
- B. Section 260526 - Grounding and Bonding for Electrical Systems.
- C. Section 260529 - Hangers and Supports for Electrical Systems.
- D. Section 260533.13 - Conduit for Electrical Systems.
- E. Section 260553 - Identification for Electrical Systems: Identification products and requirements.
- F. Section 262300 - Low-Voltage Switchgear: Service entrance equipment.
- G. Section 262413 - Switchboards: Service entrance equipment.
- H. Section 262416 - Panelboards: Service entrance equipment.

1.3 REFERENCE STANDARDS

- A. IEEE C2 - National Electrical Safety Code; 2012.
- B. NECA 1 - Standard for Good Workmanship in Electrical Construction; 2010.
- C. NFPA 70 - National Electrical Code; Most Recent Edition Adopted by Authority Having Jurisdiction, Including All Applicable Amendments and Supplements.

1.4 ADMINISTRATIVE REQUIREMENTS

- A. No later than two weeks following date of the Agreement, notify Utility Company of anticipated date of service.
- B. Coordination:
 - 1. Verify the following with Utility Company representative:
 - a. Utility Company requirements, including division of responsibility.
 - b. Exact location and details of utility point of connection.
 - c. Utility easement requirements.
 - d. Utility Company charges associated with providing service.
 - 2. Coordinate the work with other trades to avoid placement of other utilities or obstructions within the spaces dedicated for electrical service and associated equipment.
 - 3. Coordinate arrangement of service entrance equipment with the dimensions and clearance requirements of the actual equipment to be installed.
 - 4. Notify Architect of any conflicts with or deviations from Contract Documents. Obtain direction before proceeding with work.
- C. Arrange for Utility Company to provide permanent electrical service. Prepare and submit documentation required by Utility Company.
- D. Utility Company charges associated with providing permanent service to be paid by Contractor..
- E. Preinstallation Meeting: Convene one week prior to commencing work of this section to review service requirements and details with Utility Company representative.
- F. Scheduling:
 - 1. Arrange for inspections necessary to obtain Utility Company approval of installation.

1.5 SUBMITTALS

- A. Utility Company letter of availability for providing electrical service to project.

- B. Product Data: Provide manufacturer's standard catalog pages and data sheets for each product. Include ratings, configurations, standard wiring diagrams, outline and support point dimensions, finishes, weights, service condition requirements, and installed features.
- C. Shop Drawings: Include dimensioned plan views and sections indicating locations and arrangement of Utility Company and service entrance equipment, metering provisions, required clearances, and proposed service routing.
 - 1. Obtain Utility company approval of shop drawings prior to submittal.

1.6 QUALITY ASSURANCE

- A. Comply with the following:
 - 1. IEEE C2 (National Electrical Safety Code).
 - 2. NFPA 70 (National Electrical Code).
 - 3. The requirements of the Utility Company.

PART 2 PRODUCTS

2.1 ELECTRICAL SERVICE REQUIREMENTS

- A. Provide new electrical service consisting of all required conduits, conductors, equipment, metering provisions, supports, accessories, etc. as necessary for connection between Utility Company point of supply and service entrance equipment.
- B. Electrical Service Characteristics: As indicated on drawings.
- C. Utility Company: As indicated on drawings.
- D. Division of Responsibility: As indicated on drawings.
- E. Products Furnished by Contractor: Comply with Utility Company requirements.

PART 3 EXECUTION

3.1 EXAMINATION

- A. Verify that field measurements are as indicated.
- B. Verify that ratings and configurations of service entrance equipment are consistent with the indicated requirements.
- C. Verify that conditions are satisfactory for installation prior to starting work.

3.2 INSTALLATION

- A. Install products in accordance with manufacturer's instructions and Utility Company requirements.
- B. Perform work in accordance with NECA 1 (general workmanship).
- C. Arrange equipment to provide minimum clearances and required maintenance access.
- D. Provide required support and attachment components in accordance with Section 260529.
- E. Provide grounding and bonding for service entrance equipment in accordance with Section 260526.
- F. Identify service entrance equipment, including main service disconnect(s) in accordance with Section 260553.

END OF SECTION 262100

SECTION 262413
SWITCHBOARDS

PART 1 GENERAL

1.1 SECTION INCLUDES

- A. Low-voltage (600 V and less) switchboards and associated accessories for service and distribution applications.
- B. Overcurrent protective devices for switchboards.

1.2 RELATED REQUIREMENTS

- A. Section 033000 - Cast-in-Place Concrete: Concrete equipment pads.
- B. Section 260526 - Grounding and Bonding for Electrical Systems.
- C. Section 260529 - Hangers and Supports for Electrical Systems.
- D. Section 260553 - Identification for Electrical Systems: Identification products and requirements.

1.3 REFERENCE STANDARDS

- A. FS W-C-375 - Circuit Breakers, Molded Case; Branch Circuit and Service; Federal Specification; Revision E, 2013.
- B. IEEE C57.13 - IEEE Standard Requirements for Instrument Transformers; 2008.
- C. NECA 1 - Standard for Good Workmanship in Electrical Construction; 2010.
- D. NECA 400 - Standard for Installing and Maintaining Switchboards; 2007.
- E. NEMA 250 - Enclosures for Electrical Equipment (1000 Volts Maximum); 2014.
- F. NEMA PB 2 - Deadfront Distribution Switchboards; 2011.
- G. NEMA PB 2.1 - General Instructions for Proper Handling, Installation, Operation, and Maintenance of Deadfront Distribution Switchboards Rated 600 Volts or Less; 2013.
- H. NETA ATS - Acceptance Testing Specifications for Electrical Power Equipment and Systems; 2013.
- I. NFPA 70 - National Electrical Code; Most Recent Edition Adopted by Authority Having Jurisdiction, Including All Applicable Amendments and Supplements.
- J. UL 489 - Molded-Case Circuit Breakers, Molded-Case Switches and Circuit Breaker Enclosures; Current Edition, Including All Revisions.
- K. UL 869A - Reference Standard for Service Equipment; Current Edition, Including All Revisions.
- L. UL 891 - Switchboards; Current Edition, Including All Revisions.

1.4 ADMINISTRATIVE REQUIREMENTS

- A. Coordination:
 - 1. Coordinate the work with other trades to avoid placement of ductwork, piping, equipment, or other potential obstructions within the dedicated equipment spaces and working clearances required by NFPA 70.
 - 2. Coordinate arrangement of electrical equipment with the dimensions and clearance requirements of the actual equipment to be installed.
 - 3. Verify with manufacturer that conductor terminations are suitable for use with the conductors to be installed.
 - 4. Coordinate with manufacturer to provide shipping splits suitable for the dimensional constraints of the installation.
 - 5. Notify Architect of any conflicts with or deviations from Contract Documents. Obtain direction before proceeding with work.

1.5 SUBMITTALS

- A. Product Data: Provide manufacturer's standard catalog pages and data sheets for switchboards, enclosures, overcurrent protective devices, and other installed components and accessories.

- B. Shop Drawings: Indicate dimensions, voltage, bus ampacities, overcurrent protective device arrangement and sizes, short circuit current ratings, conduit entry locations, conductor terminal information, and installed features and accessories.
- C. Maintenance Data: Include information on replacement parts and recommended maintenance procedures and intervals.

1.6 QUALITY ASSURANCE

- A. Comply with requirements of NFPA 70.

1.7 DELIVERY, STORAGE, AND HANDLING

- A. Receive, inspect, handle, and store switchboards in accordance with manufacturer's instructions, NECA 400, and NEMA PB 2.1.
- B. Store in a clean, dry space having a uniform temperature to prevent condensation (including outdoor switchboards, which are not weatherproof until completely and properly installed). Where necessary, provide temporary enclosure space heaters or temporary power for permanent factory-installed space heaters.
- C. Maintain factory wrapping or provide an additional heavy canvas or heavy plastic cover to protect units from dirt, water, construction debris, and traffic.
- D. Handle carefully to avoid damage to switchboard internal components, enclosure, and finish.

1.8 FIELD CONDITIONS

- A. Maintain field conditions within required service conditions during and after installation.

PART 2 PRODUCTS

2.1 MANUFACTURERS

- A. Switchboards:
 - 1. Schneider Electric; Square D Products: www.schneider-electric.us/#sle.
 - 2. Siemens Industry, Inc: www.usa.siemens.com/#sle.
- B. Source Limitations: Furnish switchboards and associated components produced by the same manufacturer as the other electrical distribution equipment used for this project and obtained from a single supplier.

2.2 SWITCHBOARDS

- A. Provide switchboards consisting of all required components, control power transformers, instrumentation and control wiring, accessories, etc. as necessary for a complete operating system.
- B. Provide products listed, classified, and labeled as suitable for the purpose intended.
- C. Description: Dead-front switchboard assemblies complying with NEMA PB 2, and listed and labeled as complying with UL 891; ratings, configurations and features as indicated on the drawings.
- D. Front-Connected Switchboards:
 - 1. Main Device(s): Individually-mounted.
 - 2. Feeder Devices: Panel/group-mounted.
 - 3. Arrangement: Front accessible only (not rear accessible), rear aligned.
- E. Service Entrance Switchboards:
 - 1. Listed and labeled as suitable for use as service equipment according to UL 869A.
 - 2. For solidly-grounded wye systems, provide factory-installed main bonding jumper between neutral and ground busses, and removable neutral disconnecting link for testing purposes.
 - 3. Comply with Utility Company requirements for electrical service.
 - 4. Provide switchboard with phase loss protection.
- F. Service Conditions:
 - 1. Provide switchboards and associated components suitable for operation under the following service conditions without derating:
 - a. Altitude: Less than 6,600 feet.

- b. Ambient Temperature:
 - 1) Switchboards Containing Molded Case or Insulated Case Circuit Breakers: Between 23 degrees F and 104 degrees F.
- G. Short Circuit Current Rating:
 - 1. Provide switchboards with listed short circuit current rating not less than the available fault current at the installed location as indicated on the drawings.
- H. Main Devices: Configure for top or bottom incoming feed as indicated or as required for the installation. Provide separate pull section and/or top-mounted pullbox as indicated or as required to facilitate installation of incoming feed.
- I. Bussing: Sized in accordance with UL 891 temperature rise requirements.
 - 1. Through bus (horizontal cross bus) to be fully rated through full length of switchboard (non-tapered). Tapered bus is not permitted.
 - 2. Provide fully rated neutral bus unless otherwise indicated, with a suitable lug for each feeder or branch circuit requiring a neutral connection.
 - 3. Provide solidly bonded equipment ground bus through full length of switchboard, with a suitable lug for each feeder and branch circuit equipment grounding conductor.
 - 4. Phase and Neutral Bus Material: Aluminum.
 - 5. Ground Bus Material: Aluminum.
- J. Conductor Terminations: Suitable for use with the conductors to be installed.
 - 1. Line Conductor Terminations:
 - a. Main and Neutral Lug Material: Aluminum, suitable for terminating aluminum or copper conductors.
 - b. Main and Neutral Lug Type: Mechanical.
 - 2. Load Conductor Terminations:
 - a. Lug Material: Aluminum, suitable for terminating aluminum or copper conductors.
 - b. Lug Type:
- K. Enclosures:
 - 1. Environment Type per NEMA 250: Unless otherwise indicated, as specified for the following installation locations:
 - a. Indoor Clean, Dry Locations: Type 1 or Type 2 (drip-proof).
 - 2. Finish: Manufacturer's standard unless otherwise indicated.
- L. Future Provisions:
 - 1. Prepare designated spaces for future installation of devices including bussing, connectors, mounting hardware and all other required provisions.
 - 2. Equip distribution sections with full height vertical bussing to accommodate maximum utilization of space for devices.
- M. Surge Protective Devices: Where factory-installed, internally mounted surge protective devices are provided in accordance with Section 264300, list switchboards as a complete assembly including surge protective device.
- N. Instrument Transformers:
 - 1. Comply with IEEE C57.13.
 - 2. Select suitable ratio, burden, and accuracy as required for connected devices.
 - 3. Current Transformers: Connect secondaries to shorting terminal blocks.
 - 4. Potential Transformers: Include primary and secondary fuses with disconnecting means.
- O. Description: NEMA PB 2 switchboard with electrical ratings and configurations as indicated and specified.
- P. Bus Connections: Bolted, accessible from front for maintenance.
- Q. Ground Bus: Extend length of switchboard.

2.3 OVERCURRENT PROTECTIVE DEVICES

A. Circuit Breakers:

1. Interrupting Capacity:
 - a. Provide circuit breakers with interrupting capacity as required to provide the short circuit current rating indicated, but not less than specified minimum requirements.
 - b. Fully Rated Systems: Provide circuit breakers with interrupting capacity not less than the short circuit current rating indicated.
2. Molded Case Circuit Breakers:
 - a. Description: Quick-make, quick-break, over center toggle, trip-free, trip-indicating circuit breakers; listed and labeled as complying with UL 489, and complying with FS W-C-375 where applicable; ratings, configurations, and features as indicated on the drawings.
 - b. Thermal Magnetic Circuit Breakers: For each pole, furnish thermal inverse time tripping element for overload protection and magnetic instantaneous tripping element for short circuit protection.
 - 1) Provide field-adjustable magnetic instantaneous trip setting for circuit breaker frame sizes 225 amperes and larger.
 - c. Electronic Trip Circuit Breakers: Furnish solid state, microprocessor-based, true rms sensing trip units.
 - 1) Provide the following field-adjustable trip response settings:
 - (a) Long time pickup, adjustable by replacing interchangeable trip unit or by setting dial.
 - (b) Long time delay.
 - (c) Short time pickup and delay.
 - (d) Instantaneous pickup.

2.4 SOURCE QUALITY CONTROL

- A. Factory test switchboards according to NEMA PB 2, including the following production (routine) tests on each switchboard assembly or component:
 1. Dielectric tests.
 2. Mechanical operation tests.
 3. Grounding of instrument transformer cases test.
 4. Electrical operation and control wiring tests, including polarity and sequence tests.
 5. Ground-fault sensing equipment test.

PART 3 EXECUTION

3.1 EXAMINATION

- A. Verify that field measurements are as indicated.
- B. Verify that the ratings and configurations of the switchboards and associated components are consistent with the indicated requirements.
- C. Verify that mounting surfaces are ready to receive switchboards.
- D. Verify that conditions are satisfactory for installation prior to starting work.

3.2 INSTALLATION

- A. Install products in accordance with manufacturer's instructions.
- B. Install switchboards in accordance with NECA 1 (general workmanship), NECA 400, and NEMA PB 2.1.
- C. Where switchboard is indicated to be mounted with inaccessible side against wall, provide minimum clearance of 1/2 inch between switchboard and wall.
- D. Provide required support and attachment in accordance with Section 260529.
- E. Install switchboards plumb and level.
- F. Unless otherwise indicated, mount switchboards on properly sized 4 inch high concrete pad constructed in accordance with Section 033000.

- G. Provide grounding and bonding in accordance with Section 260526.
- H. Install all field-installed devices, components, and accessories.
- I. Where accessories are not self-powered, provide control power source as indicated or as required to complete installation.
- J. Set field-adjustable ground fault protection pickup and time delay settings as indicated.
- K. Provide filler plates to cover unused spaces in switchboards.
- L. Identify switchboards in accordance with Section 260553.
- M. Install switchboard in locations shown on drawings, according to NEMA PB 2.1.
- N. Install in a neat and workmanlike manner, as specified in NECA 400.
- O. Tighten accessible bus connections and mechanical fasteners after placing switchboard.

3.3 FIELD QUALITY CONTROL

- A. See Section 014000 - Quality Requirements, for additional requirements.
- B. Disconnect surge protective devices (SPDs) prior to performing any high potential testing. Replace SPDs damaged by performing high potential testing with SPDs connected.
- C. Before energizing switchboard, perform insulation resistance testing in accordance with NECA 400 and NEMA PB 2.1.
- D. Perform field inspection and testing in accordance with Section 014000.
- E. Inspect and test in accordance with NETA ATS, except Section 4.
- F. Perform inspections and tests listed in NETA ATS, Section 7.1.
- G. Molded Case and Insulated Case Circuit Breakers: Perform inspections and tests listed in NETA ATS, Section 7.6.1.1 for all main circuit breakers. Tests listed as optional are not required.
- H. Instrument Transformers: Perform inspections and tests listed in NETA ATS, Section 7.10. The dielectric withstand tests on primary windings with secondary windings connected to ground listed as optional are not required.
- I. Correct deficiencies and replace damaged or defective switchboards or associated components.

3.4 ADJUSTING

- A. Adjust tightness of mechanical and electrical connections to manufacturer's recommended torque settings.
- B. Adjust alignment of switchboard covers and doors.
- C. Adjust all operating mechanisms for free mechanical movement.
- D. Tighten bolted bus connections in accordance with manufacturer's instructions.

3.5 CLEANING

- A. Clean dirt and debris from switchboard enclosures and components according to manufacturer's instructions.
- B. Repair scratched or marred surfaces to match original factory finish.

3.6 PROTECTION

- A. Protect installed switchboards from subsequent construction operations.

END OF SECTION 262413

SECTION 262416
PANELBOARDS

PART 1 GENERAL

1.1 SECTION INCLUDES

- A. Lighting and appliance panelboards.
- B. Load centers.
- C. Overcurrent protective devices for panelboards.

1.2 RELATED REQUIREMENTS

- A. Section 260526 - Grounding and Bonding for Electrical Systems.
- B. Section 260526 - Grounding and Bonding for Electrical Systems.
- C. Section 260529 - Hangers and Supports for Electrical Systems.
- D. Section 260553 - Identification for Electrical Systems: Identification products and requirements.
- E. Section 264300 - Surge Protective Devices.

1.3 REFERENCE STANDARDS

- A. NECA 1 - Standard for Good Workmanship in Electrical Construction; 2010.
- B. NECA 407 - Standard for Installing and Maintaining Panelboards; 2009.
- C. NEMA 250 - Enclosures for Electrical Equipment (1000 Volts Maximum); 2014.
- D. NEMA PB 1 - Panelboards; 2011.
- E. NEMA PB 1.1 - General Instructions for Proper Installation, Operation and Maintenance of Panelboards Rated 600 Volts or Less; 2013.
- F. NETA ATS - Acceptance Testing Specifications for Electrical Power Equipment and Systems; 2013.
- G. NFPA 70 - National Electrical Code; Most Recent Edition Adopted by Authority Having Jurisdiction, Including All Applicable Amendments and Supplements.
- H. UL 50 - Enclosures for Electrical Equipment, Non-Environmental Considerations; Current Edition, Including All Revisions.
- I. UL 50E - Enclosures for Electrical Equipment, Environmental Considerations; Current Edition, Including All Revisions.
- J. UL 67 - Panelboards; Current Edition, Including All Revisions.
- K. UL 489 - Molded-Case Circuit Breakers, Molded-Case Switches and Circuit Breaker Enclosures; Current Edition, Including All Revisions.
- L. UL 869A - Reference Standard for Service Equipment; Current Edition, Including All Revisions.
- M. UL 943 - Ground-Fault Circuit-Interrupters; Current Edition, Including All Revisions.
- N. UL 1699 - Arc-Fault Circuit-Interrupters; Current Edition, Including All Revisions.

1.4 ADMINISTRATIVE REQUIREMENTS

- A. Coordination:
 - 1. Coordinate the work with other trades to avoid placement of ductwork, piping, equipment, or other potential obstructions within the dedicated equipment spaces and working clearances for electrical equipment required by NFPA 70.
 - 2. Coordinate arrangement of electrical equipment with the dimensions and clearance requirements of the actual equipment to be installed.
 - 3. Coordinate the work with other trades to provide walls suitable for installation of flush-mounted panelboards where indicated.
 - 4. Verify with manufacturer that conductor terminations are suitable for use with the conductors to be installed.

5. Notify Architect of any conflicts with or deviations from Contract Documents. Obtain direction before proceeding with work.

1.5 SUBMITTALS

- A. Product Data: Provide manufacturer's standard catalog pages and data sheets for panelboards, enclosures, overcurrent protective devices, and other installed components and accessories.
 1. Include characteristic trip curves for each type and rating of overcurrent protective device upon request.
- B. Shop Drawings: Indicate outline and support point dimensions, voltage, main bus ampacity, overcurrent protective device arrangement and sizes, short circuit current ratings, conduit entry locations, conductor terminal information, and installed features and accessories.
 1. Clearly indicate whether proposed short circuit current ratings are fully rated or, where acceptable, series rated systems.
 2. Include documentation of listed series ratings upon request.
- C. Manufacturer's Installation Instructions: Indicate application conditions and limitations of use stipulated by product testing agency. Include instructions for storage, handling, protection, examination, preparation, and installation of product.
- D. Project Record Documents: Record actual installed locations of panelboards and actual installed circuiting arrangements.
- E. Maintenance Data: Include information on replacement parts and recommended maintenance procedures and intervals.
- F. Maintenance Materials: Furnish the following for Owner's use in maintenance of project.
 1. Panelboard Keys: Two of each different key.

1.6 QUALITY ASSURANCE

- A. Comply with requirements of NFPA 70.

1.7 DELIVERY, STORAGE, AND HANDLING

- A. Receive, inspect, handle, and store panelboards in accordance with manufacturer's instructions and NECA 407.
- B. Store in a clean, dry space. Maintain factory wrapping or provide an additional heavy canvas or heavy plastic cover to protect units from dirt, water, construction debris, and traffic.
- C. Handle carefully in accordance with manufacturer's written instructions to avoid damage to panelboard internal components, enclosure, and finish.

1.8 FIELD CONDITIONS

- A. Maintain ambient temperature within the following limits during and after installation of panelboards:
 1. Panelboards Containing Circuit Breakers: Between 23 degrees F and 104 degrees F.

PART 2 PRODUCTS

2.1 MANUFACTURERS

- A. Siemens Industry, Inc: www.usa.siemens.com.
- B. Schneider Electric; Square D Products; _____: www.schneider-electric.us/#sle.
- C. Substitutions: See Section 016000 - Product Requirements.
- D. Source Limitations: Furnish panelboards and associated components produced by the same manufacturer as the other electrical distribution equipment used for this project and obtained from a single supplier.

2.2 PANELBOARDS - GENERAL REQUIREMENTS

- A. Provide products listed, classified, and labeled as suitable for the purpose intended.
- B. Unless otherwise indicated, provide products suitable for continuous operation under the following service conditions:
 1. Altitude: Less than 6,600 feet.

2. Ambient Temperature:
 - a. Panelboards Containing Circuit Breakers: Between 23 degrees F and 104 degrees F.
- C. Short Circuit Current Rating:
 1. Provide panelboards with listed short circuit current rating not less than the available fault current at the installed location as indicated on the drawings.
 2. Listed series ratings are acceptable, except where not permitted by motor contribution according to NFPA 70.
 3. Label equipment utilizing series ratings as required by NFPA 70.
- D. Mains: Configure for top or bottom incoming feed as indicated or as required for the installation.
- E. Branch Overcurrent Protective Devices: Replaceable without disturbing adjacent devices.
- F. Bussing: Sized in accordance with UL 67 temperature rise requirements.
 1. Provide fully rated neutral bus unless otherwise indicated, with a suitable lug for each feeder or branch circuit requiring a neutral connection.
 2. Provide solidly bonded equipment ground bus in each panelboard, with a suitable lug for each feeder and branch circuit equipment grounding conductor.
- G. Conductor Terminations: Suitable for use with the conductors to be installed.
- H. Enclosures: Comply with NEMA 250, and list and label as complying with UL 50 and UL 50E.
 1. Environment Type per NEMA 250: Unless otherwise indicated, as specified for the following installation locations:
 - a. Indoor Clean, Dry Locations: Type 1.
 2. Boxes: Galvanized steel unless otherwise indicated.
 - a. Provide wiring gutters sized to accommodate the conductors to be installed.
 - b. Increase gutter space as required where sub-feed lugs, feed-through lugs, gutter taps, or oversized lugs are provided.
 3. Fronts:
 - a. Fronts for Surface-Mounted Enclosures: Same dimensions as boxes.
 - b. Fronts for Flush-Mounted Enclosures: Overlap boxes on all sides to conceal rough opening.
 - c. Finish for Painted Steel Fronts: Manufacturer's standard grey unless otherwise indicated.
 4. Lockable Doors: All locks keyed alike unless otherwise indicated.
- I. Future Provisions: Prepare all unused spaces for future installation of devices including bussing, connectors, mounting hardware and all other required provisions.
- J. Surge Protective Devices: Where factory-installed, internally mounted surge protective devices are provided in accordance with Section 264300, list and label panelboards as a complete assembly including surge protective device.
- K. Multi-Section Panelboards: Provide enclosures of the same height, with feed-through lugs and feeders as indicated or as required to interconnect sections.
- L. Load centers are not acceptable.
- M. Provide the following features and accessories where indicated or where required to complete installation:
 1. Feed-through lugs.
 2. Sub-feed lugs.

2.3 LIGHTING AND APPLIANCE PANELBOARDS

- A. Description: Panelboards complying with NEMA PB 1, lighting and appliance branch circuit type, circuit breaker type, and listed and labeled as complying with UL 67; ratings, configurations and features as indicated on the drawings.
- B. Conductor Terminations:
 1. Main and Neutral Lug Material: Aluminum, suitable for terminating aluminum or copper conductors.
 2. Main and Neutral Lug Type: Mechanical.
- C. Bussing:

1. Phase Bus Connections: Arranged for sequential phasing of overcurrent protective devices.
 2. Phase and Neutral Bus Material: Aluminum or copper.
 3. Ground Bus Material: Aluminum or copper.
- D. Circuit Breakers: Thermal magnetic bolt-on type unless otherwise indicated.
- E. Enclosures:
1. Provide surface-mounted or flush-mounted enclosures as indicated.
 2. Fronts: Provide lockable hinged door with concealed hinges for access to overcurrent protective device handles without exposing live parts.
 3. Provide clear plastic circuit directory holder mounted on inside of door.
- 2.4 LOAD CENTERS
- A. Description: Circuit breaker type load centers listed and labeled as complying with UL 67; ratings, configurations, and features as indicated on the drawings.
- B. Bussing:
1. Phase Bus Connections: Arranged for sequential phasing of overcurrent protective devices.
 2. Bus Material: Aluminum or copper.
- C. Circuit Breakers: Thermal magnetic plug-in type.
- D. Enclosures:
1. Provide flush-mounted enclosures unless otherwise indicated.
 2. Provide circuit directory label on inside of door or individual circuit labels adjacent to circuit breakers.
- 2.5 OVERCURRENT PROTECTIVE DEVICES
- A. Molded Case Circuit Breakers:
1. Description: Quick-make, quick-break, over center toggle, trip-free, trip-indicating circuit breakers listed and labeled as complying with UL 489; ratings, configurations, and features as indicated on the drawings.
 2. Interrupting Capacity:
 - a. Provide circuit breakers with interrupting capacity as required to provide the short circuit current rating indicated.
 - b. Fully Rated Systems: Provide circuit breakers with interrupting capacity not less than the short circuit current rating indicated.
 - c. Series Rated Systems: Provide circuit breakers listed in combination with upstream devices to provide interrupting rating not less than the short circuit current rating indicated.
 3. Conductor Terminations:
 - a. Provide mechanical lugs unless otherwise indicated.
 - b. Lug Material: Aluminum, suitable for terminating aluminum or copper conductors.
 4. Thermal Magnetic Circuit Breakers: For each pole, furnish thermal inverse time tripping element for overload protection and magnetic instantaneous tripping element for short circuit protection.
 5. Multi-Pole Circuit Breakers: Furnish with common trip for all poles.
 6. Provide the following circuit breaker types where indicated:
 - a. Ground Fault Circuit Interrupter (GFCI) Circuit Breakers: Listed as complying with UL 943, class A for protection of personnel.
 - b. Ground Fault Equipment Protection Circuit Breakers: Designed to trip at 30 mA for protection of equipment.
 - c. Arc-Fault Circuit Interrupter (AFCI) Circuit Breakers: Combination type listed as complying with UL 1699.
 - d. 100 Percent Rated Circuit Breakers: Listed for application within the panelboard where installed at 100 percent of the continuous current rating.
 7. Provide listed switching duty rated circuit breakers with SWD marking for all branch circuits serving fluorescent lighting.
 8. Do not use tandem circuit breakers.
 9. Do not use handle ties in lieu of multi-pole circuit breakers.

10. Provide multi-pole circuit breakers for multi-wire branch circuits as required by NFPA 70.
11. Provide the following features and accessories where indicated or where required to complete installation:
 - a. Handle Pad-Lock Provision: For locking circuit breaker handle in OFF position.

2.6 SOURCE QUALITY CONTROL

- A. Factory test panelboards according to NEMA PB 1.

PART 3 EXECUTION

3.1 EXAMINATION

- A. Verify that field measurements are as indicated.
- B. Verify that the ratings and configurations of the panelboards and associated components are consistent with the indicated requirements.
- C. Verify that mounting surfaces are ready to receive panelboards.
- D. Verify that conditions are satisfactory for installation prior to starting work.

3.2 INSTALLATION

- A. Perform work in accordance with NECA 1 (general workmanship).
- B. Install products in accordance with manufacturer's instructions.
- C. Install panelboards in accordance with NECA 407 and NEMA PB 1.1.
- D. Arrange equipment to provide minimum clearances in accordance with manufacturer's instructions and NFPA 70.
- E. Provide required support and attachment in accordance with Section 260529.
- F. Install panelboards plumb.
- G. Install flush-mounted panelboards so that trims fit completely flush to wall with no gaps and rough opening completely covered.
- H. Mount panelboards such that the highest position of any operating handle for circuit breakers or switches does not exceed 79 inches above the floor or working platform.
- I. Provide minimum of six spare 1 inch trade size conduits out of each flush-mounted panelboard stubbed into accessible space above ceiling.
- J. Provide grounding and bonding in accordance with Section 260526.
- K. Install all field-installed branch devices, components, and accessories.
- L. Multi-Wire Branch Circuits: Group grounded and ungrounded conductors together in the panelboard as required by NFPA 70.
- M. Provide filler plates to cover unused spaces in panelboards.
- N. Provide circuit breaker lock-on devices to prevent unauthorized personnel from de-energizing essential loads where indicated. Also provide for the following:
 1. Fire detection and alarm circuits.
 2. Communications equipment circuits.
- O. Identify panelboards in accordance with Section 260553.

3.3 FIELD QUALITY CONTROL

- A. See Section 014000 - Quality Requirements, for additional requirements.
- B. Perform inspection, testing, and adjusting in accordance with Section 014000.
- C. Inspect and test in accordance with NETA ATS, except Section 4.
- D. Molded Case Circuit Breakers: Perform inspections and tests listed in NETA ATS, Section 7.6.1.1 for all main circuit breakers and circuit breakers larger than _____ amperes. Tests listed as optional are not required.

- E. Test GFCI circuit breakers to verify proper operation.
- F. Test AFCI circuit breakers to verify proper operation.
- G. Correct deficiencies and replace damaged or defective panelboards or associated components.

3.4 ADJUSTING

- A. Adjust tightness of mechanical and electrical connections to manufacturer's recommended torque settings.
- B. Adjust alignment of panelboard fronts.

3.5 CLEANING

- A. Clean dirt and debris from panelboard enclosures and components according to manufacturer's instructions.
- B. Repair scratched or marred exterior surfaces to match original factory finish.

END OF SECTION 262416

SECTION 262726
WIRING DEVICES

PART 1 GENERAL

1.1 SECTION INCLUDES

- A. Wall switches.
- B. Wall dimmers.
- C. Receptacles.
- D. Wall plates.

1.2 RELATED REQUIREMENTS

- A. Section 260526 - Grounding and Bonding for Electrical Systems.
- B. Section 260533.16 - Boxes for Electrical Systems.
- C. Section 260533.16 - Boxes for Electrical Systems.
- D. Section 260553 - Identification for Electrical Systems: Identification products and requirements.
- E. Section 260923 - Lighting Control Devices: Devices for automatic control of lighting, including occupancy sensors, in-wall time switches, and in-wall interval timers.
- F. Section 260583 - Equipment Wiring: Cords and plugs for equipment.

1.3 REFERENCE STANDARDS

- A. NECA 1 - Standard for Good Workmanship in Electrical Construction; 2010.
- B. NECA 130 - Standard for Installing and Maintaining Wiring Devices; 2010.
- C. NEMA WD 1 - General Color Requirements for Wiring Devices; 1999 (R 2010).
- D. NEMA WD 6 - Wiring Devices - Dimensional Specifications; 2012.
- E. NFPA 70 - National Electrical Code; Most Recent Edition Adopted by Authority Having Jurisdiction, Including All Applicable Amendments and Supplements.
- F. UL 20 - General-Use Snap Switches; Current Edition, Including All Revisions.
- G. UL 498 - Attachment Plugs and Receptacles; Current Edition, Including All Revisions.
- H. UL 514D - Cover Plates for Flush-Mounted Wiring Devices; Current Edition, Including All Revisions.
- I. UL 943 - Ground-Fault Circuit-Interrupters; Current Edition, Including All Revisions.

1.4 ADMINISTRATIVE REQUIREMENTS

- A. Coordination:
 - 1. Coordinate the placement of outlet boxes with millwork, furniture, equipment, etc. installed under other sections or by others.
 - 2. Coordinate wiring device ratings and configurations with the electrical requirements of actual equipment to be installed.
 - 3. Coordinate the installation and preparation of uneven surfaces, such as split face block, to provide suitable surface for installation of wiring devices.
 - 4. Notify Architect of any conflicts or deviations from Contract Documents to obtain direction prior to proceeding with work.
- B. Sequencing:
 - 1. Do not install wiring devices until final surface finishes and painting are complete.

1.5 SUBMITTALS

- A. See Section 013000 - Administrative Requirements, for submittal procedures.
- B. Product Data: Provide manufacturer's catalog information showing dimensions, colors, and configurations.
- C. Operation and Maintenance Data:

1. GFCI Receptacles: Include information on status indicators.
 - D. Project Record Documents: Record actual installed locations of wiring devices.
- 1.6 QUALITY ASSURANCE
- A. Comply with requirements of NFPA 70.
 - B. Products: Listed, classified, and labeled as suitable for the purpose intended.
- 1.7 DELIVERY, STORAGE, AND PROTECTION
- A. Store in a clean, dry space in original manufacturer's packaging until ready for installation.

PART 2 PRODUCTS

2.1 MANUFACTURERS

- A. Arrow Hart, a brand of Cooper Industries; www.cooperindustries.com
- B. Hubbell Incorporated; : www.hubbell-wiring.com.
- C. Leviton Manufacturing Company, Inc; : www.leviton.com.
- D. Pass & Seymour, a brand of Legrand North America, Inc; : www.legrand.us
- E. Substitutions: See Section 016000 - Product Requirements.
- F. Source Limitations: Where possible, for each type of wiring device furnish products produced by a single manufacturer and obtained from a single supplier.

2.2 WIRING DEVICE APPLICATIONS

- A. Provide wiring devices suitable for intended use and with ratings adequate for load served.
- B. For single receptacles installed on an individual branch circuit, provide receptacle with ampere rating not less than that of the branch circuit.
- C. Provide weather resistant GFCI receptacles with specified weatherproof covers for receptacles installed outdoors or in damp or wet locations.
- D. Provide GFCI protection for receptacles installed within 6 feet of sinks.
- E. Provide GFCI protection for receptacles installed in kitchens.
- F. Provide GFCI protection for receptacles serving electric drinking fountains.
- G. Unless noted otherwise, do not use combination switch/receptacle devices.

2.3 ALL WIRING DEVICES

- A. Provide products listed and classified by testing firm acceptable to the authority having jurisdiction as suitable for the purpose specified and indicated.
- B. Finishes:
 1. Wiring Devices Installed in Finished Spaces: Color as selected by Architect with nylon wall plate unless otherwise indicated.
 2. Wiring Devices Installed in Unfinished Spaces: Gray with galvanized steel wall plate unless otherwise indicated.
 3. Wiring Devices Installed in Wet or Damp Locations: Gray with specified weatherproof cover unless otherwise indicated.

2.4 WALL SWITCHES

- A. Wall Switches - General Requirements: AC only, quiet operating, general-use snap switches with silver alloy contacts, complying with NEMA WD 1 and NEMA WD 6, and listed as complying with UL 20 and where applicable, FS W-S-896; types as indicated on the drawings.
 1. Wiring Provisions: Terminal screws for side wiring and screw actuated binding clamp for back wiring with separate ground terminal screw.
- B. Standard Wall Switches: Industrial specification grade, 20 A, 120/277 V with standard toggle type switch actuator and maintained contacts; single pole single throw, double pole single throw, three way, or four way as indicated on the drawings.

2.5 WALL DIMMERS

- A. Wall Dimmers - General Requirements: Solid-state with continuous full-range even control following square law dimming curve, integral radio frequency interference filtering, power failure preset memory, air gap switch accessible without removing wall plate, complying with NEMA WD 1 and NEMA WD 6, and listed as complying with UL 1472; types and ratings suitable for load controlled as indicated on the drawings.
- B. Control: Slide control type with separate on/off switch.
- C. Power Rating, Unless Otherwise Indicated or Required to Control the Load Indicated on the Drawings:
 - 1. Incandescent: 2000 W.
 - 2. 0-10V LED: 1500 VA

2.6 RECEPTACLES

- A. Receptacles - General Requirements: Self-grounding, complying with NEMA WD 1 and NEMA WD 6, and listed as complying with UL 498, and where applicable, FS W-C-596; types as indicated on the drawings.
 - 1. Wiring Provisions: Terminal screws for side wiring or screw actuated binding clamp for back wiring with separate ground terminal screw.
 - 2. NEMA configurations specified are according to NEMA WD 6.
- B. Convenience Receptacles:
 - 1. Standard Convenience Receptacles: Industrial specification grade, 20A, 125V, NEMA 5-20R; single or duplex as indicated on the drawings.
 - 2. Weather Resistant Convenience Receptacles: Industrial specification grade, 20A, 125V, NEMA 5-20R, listed and labeled as weather resistant type complying with UL 498 Supplement SE suitable for installation in damp or wet locations; single or duplex as indicated on the drawings.
 - 3. Tamper Resistant Convenience Receptacles: Industrial specification grade, 20A, 125V, NEMA 5-20R, listed and labeled as tamper resistant type; single or duplex as indicated on the drawings.
- C. GFCI Receptacles:
 - 1. GFCI Receptacles - General Requirements: Self-testing, with feed-through protection and light to indicate ground fault tripped condition and loss of protection; listed as complying with UL 943, class A.
 - a. Provide test and reset buttons of same color as device.
 - 2. Standard GFCI Receptacles: Industrial specification grade, duplex, 20A, 125V, NEMA 5-20R, rectangular decorator style.
 - 3. Weather Resistant GFCI Receptacles: Industrial specification grade, duplex, 20A, 125V, NEMA 5-20R, rectangular decorator style, listed and labeled as weather resistant type complying with UL 498 Supplement SE suitable for installation in damp or wet locations.
 - 4. Tamper Resistant GFCI Receptacles: Industrial specification grade, duplex, 20A, 125V, NEMA 5-20R, rectangular decorator style, listed and labeled as tamper resistant type.

2.7 WALL PLATES

- A. Wall Plates: Comply with UL 514D.
 - 1. Configuration: One piece cover as required for quantity and types of corresponding wiring devices.
 - 2. Size: Standard; .
 - 3. Screws: Metal with slotted heads finished to match wall plate finish.
- B. Nylon Wall Plates: Smooth finish, high-impact thermoplastic.
- C. Galvanized Steel Wall Plates: Rounded corners and edges, with corrosion resistant screws.
- D. Weatherproof Covers for Damp Locations: Gasketed, cast aluminum, with self-closing hinged cover and corrosion-resistant screws; listed as suitable for use in wet locations with cover closed.
- E. Weatherproof Covers for Wet Locations: Gasketed, cast aluminum, with hinged lockable cover and corrosion-resistant screws; listed as suitable for use in wet locations while in use with attachment plugs connected and identified as extra-duty type.

PART 3 EXECUTION

3.1 EXAMINATION

- A. Verify that field measurements are as indicated.
- B. Verify that outlet boxes are installed in proper locations and at proper mounting heights and are properly sized to accommodate devices and conductors in accordance with NFPA 70.
- C. Verify that wall openings are neatly cut and will be completely covered by wall plates.
- D. Verify that final surface finishes are complete, including painting.
- E. Verify that branch circuit wiring installation is completed, tested, and ready for connection to wiring devices.
- F. Verify that conditions are satisfactory for installation prior to starting work.

3.2 PREPARATION

- A. Provide extension rings to bring outlet boxes flush with finished surface.
- B. Clean dirt, debris, plaster, and other foreign materials from outlet boxes.

3.3 INSTALLATION

- A. Perform work in accordance with NECA 1 (general workmanship) and, where applicable, NECA 130, including mounting heights specified in those standards unless otherwise indicated.
- B. Coordinate locations of outlet boxes provided under Section 260533.16 as required for installation of wiring devices provided under this section.
 - 1. Mounting Heights: Unless otherwise indicated, as follows:
 - 2. Orient outlet boxes for vertical installation of wiring devices unless otherwise indicated.
 - 3. Where multiple receptacles or wall switches are installed at the same location and at the same mounting height, gang devices together under a common wall plate.
 - 4. Locate wall switches on strike side of door with edge of wall plate 3 inches from edge of door frame. Where locations are indicated otherwise, notify Architect to obtain direction prior to proceeding with work.
 - 5. Locate receptacles for electric drinking fountains concealed behind drinking fountain according to manufacturer's instructions.
- C. Install wiring devices in accordance with manufacturer's instructions.
- D. Install permanent barrier between ganged wiring devices when voltage between adjacent devices exceeds 300 V.
- E. Where required, connect wiring devices using pigtails not less than 6 inches long. Do not connect more than one conductor to wiring device terminals.
- F. Connect wiring devices by wrapping conductor clockwise 3/4 turn around screw terminal and tightening to proper torque specified by the manufacturer. Where present, do not use push-in pressure terminals that do not rely on screw-actuated binding.
- G. Unless otherwise indicated, connect wiring device grounding terminal to branch circuit equipment grounding conductor and to outlet box with bonding jumper.
- H. Provide GFCI receptacles with integral GFCI protection at each location indicated. Do not use feed-through wiring to protect downstream devices.
- I. Where split-wired duplex receptacles are indicated, remove tabs connecting top and bottom receptacles.
- J. Install wiring devices plumb and level with mounting yoke held rigidly in place.
- K. Install wall switches with OFF position down.
- L. Install wall dimmers to achieve full rating specified and indicated after derating for ganging as instructed by manufacturer.
- M. Do not share neutral conductor on branch circuits utilizing wall dimmers.

- N. Install vertically mounted receptacles with grounding pole on bottom and horizontally mounted receptacles with grounding pole on left.
- O. Install wall plates to fit completely flush to wall with no gaps and rough opening completely covered without strain on wall plate. Repair or reinstall improperly installed outlet boxes or improperly sized rough openings. Do not use oversized wall plates in lieu of meeting this requirement.
- P. Install blank wall plates on junction boxes and on outlet boxes with no wiring devices installed or designated for future use.
- Q. Identify wiring devices in accordance with Section 260553.

3.4 FIELD QUALITY CONTROL

- A. See Section 014000 - Quality Requirements, for additional requirements.
- B. Perform field inspection, testing, and adjusting in accordance with Section 014000.
- C. Inspect each wiring device for damage and defects.
- D. Operate each wall switch with circuit energized to verify proper operation.
- E. Test each receptacle to verify operation and proper polarity.
- F. Test each GFCI receptacle for proper tripping operation according to manufacturer's instructions.
- G. Correct wiring deficiencies and replace damaged or defective wiring devices.

3.5 ADJUSTING

- A. Adjust devices and wall plates to be flush and level.

3.6 CLEANING

- A. Clean exposed surfaces to remove dirt, paint, or other foreign material and restore to match original factory finish.

END OF SECTION 262726

SECTION 262813

FUSES

PART 1 GENERAL

1.1 SECTION INCLUDES

- A. Fuses.

1.2 RELATED REQUIREMENTS

- A. Section 262816.16 - Enclosed Switches: Fusible switches.

1.3 REFERENCE STANDARDS

- A. NEMA FU 1 - Low Voltage Cartridge Fuses; 2012.
- B. NFPA 70 - National Electrical Code; Most Recent Edition Adopted by Authority Having Jurisdiction, Including All Applicable Amendments and Supplements.
- C. UL 248-1 - Low-Voltage Fuses - Part 1: General Requirements; Current Edition, Including All Revisions.
- D. UL 248-8 - Low-Voltage Fuses - Part 8: Class J Fuses; Current Edition, Including All Revisions.
- E. UL 248-12 - Low-Voltage Fuses - Part 12: Class R Fuses; Current Edition, Including All Revisions.

1.4 ADMINISTRATIVE REQUIREMENTS

- A. Coordination:
 - 1. Coordinate fuse clips furnished in equipment provided under other sections for compatibility with indicated fuses.
 - a. Fusible Enclosed Switches: See Section 262816.16.
 - 2. Coordinate fuse requirements according to manufacturer's recommendations and nameplate data for actual equipment to be installed.
 - 3. Notify Architect of any conflicts with or deviations from Contract Documents. Obtain direction before proceeding with work.

1.5 SUBMITTALS

- A. Product Data: Provide manufacturer's standard data sheets including voltage and current ratings, interrupting ratings, time-current curves, and current limitation curves.
- B. Maintenance Materials: Furnish the following for Owner's use in maintenance of project.
 - 1. See Section 016000 - Product Requirements, for additional provisions.
 - 2. Extra Fuses: One set(s) of three for each type and size installed.
 - 3. Fuse Pullers: One set(s) compatible with each type and size installed.

1.6 QUALITY ASSURANCE

- A. Comply with requirements of NFPA 70.

PART 2 PRODUCTS

2.1 MANUFACTURERS

- A. Bussmann, a division of Eaton Corporation; _____: www.cooperindustries.com/#sle.
- B. Mersen (formerly Ferraz Shawmut): ferrazshawmut.mersen.com.
- C. Littelfuse, Inc; _____: www.littelfuse.com/#sle.
- D. Substitutions: See Section 016000 - Product Requirements.

2.2 APPLICATIONS

- A. Feeders:
 - 1. Fusible Switches up to 600 Amperes: Class J, time-delay.
- B. General Purpose Branch Circuits: Class RK1, time-delay.

2.3 FUSES

- A. Provide products listed, classified, and labeled as suitable for the purpose intended.

- B. Unless specifically indicated to be excluded, provide fuses for all fusible equipment as required for a complete operating system.
- C. Provide fuses of the same type, rating, and manufacturer within the same switch.
- D. Comply with UL 248-1.
- E. Unless otherwise indicated, provide cartridge type fuses complying with NEMA FU 1, Class and ratings as indicated.
- F. Voltage Rating: Suitable for circuit voltage.
- G. Class R Fuses: Comply with UL 248-12.
- H. Class J Fuses: Comply with UL 248-8.
- I. Selectivity: Where the requirement for selectivity is indicated, furnish products as required to achieve selective coordination.
- J. Provide the following accessories where indicated or where required to complete installation:
 - 1. Fuseholders: Compatible with indicated fuses.
 - 2. Fuse Reducers: For adapting indicated fuses to permit installation in switch designed for fuses with larger ampere ratings.

PART 3 EXECUTION

3.1 EXAMINATION

- A. Verify that fuse ratings are consistent with circuit voltage and manufacturer's recommendations and nameplate data for equipment.
- B. Verify that conditions are satisfactory for installation prior to starting work.

3.2 INSTALLATION

- A. Do not install fuses until circuits are ready to be energized.
- B. Install fuses with label oriented such that manufacturer, type, and size are easily read.

END OF SECTION 262813

SECTION 262816.16
ENCLOSED SWITCHES

PART 1 GENERAL

1.1 SECTION INCLUDES

- A. Enclosed safety switches.

1.2 RELATED REQUIREMENTS

- A. Section 260526 - Grounding and Bonding for Electrical Systems.
- B. Section 260529 - Hangers and Supports for Electrical Systems.
- C. Section 260553 - Identification for Electrical Systems: Identification products and requirements.
- D. Section 262813 - Fuses.

1.3 REFERENCE STANDARDS

- A. NECA 1 - Standard for Good Workmanship in Electrical Construction; 2010.
- B. NEMA 250 - Enclosures for Electrical Equipment (1000 Volts Maximum); 2014.
- C. NEMA KS 1 - Heavy Duty Enclosed and Dead-Front Switches (600 Volts Maximum); 2013.
- D. NFPA 70 - National Electrical Code; Most Recent Edition Adopted by Authority Having Jurisdiction, Including All Applicable Amendments and Supplements.
- E. UL 50 - Enclosures for Electrical Equipment, Non-Environmental Considerations; Current Edition, Including All Revisions.
- F. UL 50E - Enclosures for Electrical Equipment, Environmental Considerations; Current Edition, Including All Revisions.
- G. UL 98 - Enclosed and Dead-Front Switches; Current Edition, Including All Revisions.

1.4 ADMINISTRATIVE REQUIREMENTS

- A. Coordination:
 - 1. Coordinate the work with other trades. Avoid placement of ductwork, piping, equipment, or other potential obstructions within the dedicated equipment spaces and within working clearances for electrical equipment required by NFPA 70.
 - 2. Coordinate arrangement of electrical equipment with the dimensions and clearance requirements of the actual equipment to be installed.
 - 3. Verify with manufacturer that conductor terminations are suitable for use with the conductors to be installed.
 - 4. Notify Architect of any conflicts with or deviations from Contract Documents. Obtain direction before proceeding with work.

1.5 SUBMITTALS

- A. See Section 013000 - Administrative Requirements, for submittal procedures.
- B. Product Data: Provide manufacturer's standard catalog pages and data sheets for enclosed switches and other installed components and accessories.
- C. Shop Drawings: Indicate outline and support point dimensions, voltage and current ratings, short circuit current ratings, conduit entry locations, conductor terminal information, and installed features and accessories.
- D. Manufacturer's Installation Instructions: Indicate application conditions and limitations of use stipulated by product testing agency. Include instructions for storage, handling, protection, examination, preparation, installation, and starting of product.
- E. Project Record Documents: Record actual locations of enclosed switches.
- F. Maintenance Data: Include information on replacement parts and recommended maintenance procedures and intervals.

1.6 QUALITY ASSURANCE

- A. Comply with requirements of NFPA 70.

1.7 DELIVERY, STORAGE, AND HANDLING

- A. Store in a clean, dry space. Maintain factory wrapping or provide an additional heavy canvas or heavy plastic cover to protect units from dirt, water, construction debris, and traffic.
- B. Handle carefully in accordance with manufacturer's written instructions to avoid damage to enclosed switch internal components, enclosure, and finish.

1.8 FIELD CONDITIONS

- A. Maintain ambient temperature between -22 degrees F and 104 degrees F during and after installation of enclosed switches.

PART 2 PRODUCTS

2.1 MANUFACTURERS

- A. Siemens Industry, Inc: www.usa.siemens.com.
- B. Schneider Electric; Square D Products; _____: www.schneider-electric.us/#sle.
- C. Substitutions: See Section 016000 - Product Requirements.
- D. Source Limitations: Furnish enclosed switches and associated components produced by the same manufacturer as the other electrical distribution equipment used for this project and obtained from a single supplier.

2.2 ENCLOSED SAFETY SWITCHES

- A. Description: Quick-make, quick-break enclosed safety switches listed and labeled as complying with UL 98; heavy duty; ratings, configurations, and features as indicated on the drawings.
- B. Provide products listed, classified, and labeled as suitable for the purpose intended.
- C. Unless otherwise indicated, provide products suitable for continuous operation under the following service conditions:
 - 1. Altitude: Less than 6,600 feet.
 - 2. Ambient Temperature: Between -22 degrees F and 104 degrees F.
- D. Horsepower Rating: Suitable for connected load.
- E. Voltage Rating: Suitable for circuit voltage.
- F. Provide with switch blade contact position that is visible when the cover is open.
- G. Fuse Clips for Fusible Switches: As required to accept fuses indicated.
 - 1. Where NEMA Class R fuses are installed, provide rejection feature to prevent installation of fuses other than Class R.
- H. Conductor Terminations: Suitable for use with the conductors to be installed.
- I. Provide insulated, groundable fully rated solid neutral assembly where a neutral connection is required, with a suitable lug for terminating each neutral conductor.
- J. Provide solidly bonded equipment ground bus in each enclosed safety switch, with a suitable lug for terminating each equipment grounding conductor.
- K. Enclosures: Comply with NEMA 250, and list and label as complying with UL 50 and UL 50E.
 - 1. Environment Type per NEMA 250: Unless otherwise indicated, as specified for the following installation locations:
 - a. Indoor Clean, Dry Locations: Type 1.
 - b. Outdoor Locations: Type 3R.
 - 2. Finish for Painted Steel Enclosures: Manufacturer's standard, factory applied grey unless otherwise indicated.
- L. Provide safety interlock to prevent opening the cover with the switch in the ON position with capability of overriding interlock for testing purposes.

- M. Heavy Duty Switches:
 - 1. Comply with NEMA KS 1.
 - 2. Conductor Terminations:
 - a. Provide mechanical lugs unless otherwise indicated.
 - b. Lug Material: Aluminum, suitable for terminating aluminum or copper conductors.
 - 3. Provide externally operable handle with means for locking in the OFF position, capable of accepting three padlocks.

PART 3 EXECUTION

3.1 EXAMINATION

- A. Verify that field measurements are as indicated.
- B. Verify that the ratings of the enclosed switches are consistent with the indicated requirements.
- C. Verify that mounting surfaces are ready to receive enclosed safety switches.
- D. Verify that conditions are satisfactory for installation prior to starting work.

3.2 INSTALLATION

- A. Install products in accordance with manufacturer's instructions.
- B. Perform work in accordance with NECA 1 (general workmanship).
- C. Arrange equipment to provide minimum clearances in accordance with manufacturer's instructions and NFPA 70.
- D. Provide required support and attachment in accordance with Section 260529.
- E. Install enclosed switches plumb.
- F. Except where indicated to be mounted adjacent to the equipment they supply, mount enclosed switches such that the highest position of the operating handle does not exceed 79 inches above the floor or working platform.
- G. Provide grounding and bonding in accordance with Section 260526.
- H. Provide fuses complying with Section 262813 for fusible switches as indicated or as required by equipment manufacturer's recommendations.
- I. Identify enclosed switches in accordance with Section 260553.

3.3 FIELD QUALITY CONTROL

- A. See Section 014000 - Quality Requirements, for additional requirements.
- B. Perform field inspection, testing, and adjusting in accordance with Section 014000.
- C. Correct deficiencies and replace damaged or defective enclosed safety switches or associated components.

3.4 ADJUSTING

- A. Adjust tightness of mechanical and electrical connections to manufacturer's recommended torque settings.

3.5 CLEANING

- A. Clean dirt and debris from switch enclosures and components according to manufacturer's instructions.
- B. Repair scratched or marred exterior surfaces to match original factory finish.

END OF SECTION 262816.16

SECTION 265100
INTERIOR LIGHTING

PART 1 GENERAL

1.1 SECTION INCLUDES

- A. Interior luminaires.
- B. Emergency lighting units.
- C. Exit signs.
- D. Ballasts and drivers.
- E. Fluorescent emergency power supply units.
- F. Lamps.
- G. Accessories.

1.2 RELATED REQUIREMENTS

- A. Section 260529 - Hangers and Supports for Electrical Systems.
- B. Section 260533.16 - Boxes for Electrical Systems.
- C. Section 260553 - Identification for Electrical Systems: Identification products and requirements.
- D. Section 260919 - Enclosed Contactors: Lighting contactors.
- E. Section 260923 - Lighting Control Devices: Automatic controls for lighting including occupancy sensors.
- F. Section 262726 - Wiring Devices: Manual wall switches.
- G. Section 265600 - Exterior Lighting.

1.3 REFERENCE STANDARDS

- A. 47 CFR 15 - Radio Frequency Devices; current edition.
- B. ANSI C82.11 - American National Standard for Lamp Ballasts - High Frequency Fluorescent Lamp Ballasts - Supplements; 2011.
- C. IEEE C62.41.2 - Recommended Practice on Characterization of Surges in Low-Voltage (1000 V and less) AC Power Circuits; 2002 (Cor 1, 2012).
- D. IES LM-79 - Approved Method: Electrical and Photometric Measurements of Solid-State Lighting Products; 2008.
- E. IES LM-79 - Approved Method: Electrical and Photometric Measurements of Solid-State Lighting Products; Illuminating Engineering Society; 2008.
- F. IES LM-80 - Approved Method: Measuring Luminous Flux and Color Maintenance of LED Packages, Arrays, and Modules; Illuminating Engineering Society; 2015.
- G. NECA 1 - Standard for Good Workmanship in Electrical Construction; 2010.
- H. NECA/IESNA 500 - Standard for Installing Indoor Commercial Lighting Systems; 2006.
- I. NECA/IESNA 502 - Standard for Installing Industrial Lighting Systems; 2006.
- J. NEMA LE 4 - Recessed Luminaires, Ceiling Compatibility; 2012.
- K. NFPA 70 - National Electrical Code; Most Recent Edition Adopted by Authority Having Jurisdiction, Including All Applicable Amendments and Supplements.
- L. NFPA 101 - Life Safety Code; 2015.
- M. UL 924 - Emergency Lighting and Power Equipment; Current Edition, Including All Revisions.
- N. UL 935 - Fluorescent-Lamp Ballasts; Current Edition, Including All Revisions.
- O. UL 1598 - Luminaires; Current Edition, Including All Revisions.
- P. UL 8750 - Light Emitting Diode (LED) Equipment for Use in Lighting Products; Current Edition, Including All Revisions.

1.4 ADMINISTRATIVE REQUIREMENTS

A. Coordination:

1. Coordinate the installation of luminaires with mounting surfaces installed under other sections or by others. Coordinate the work with placement of supports, anchors, etc. required for mounting. Coordinate compatibility of luminaires and associated trims with mounting surfaces at installed locations.
2. Coordinate the placement of luminaires with structural members, ductwork, piping, equipment, diffusers, fire suppression system components, and other potential conflicts installed under other sections or by others.
3. Coordinate the placement of exit signs with furniture, equipment, signage or other potential obstructions to visibility installed under other sections or by others.
4. Notify Architect of any conflicts or deviations from Contract Documents to obtain direction prior to proceeding with work.

1.5 SUBMITTALS

A. Shop Drawings:

1. Indicate dimensions and components for each luminaire that is not a standard product of the manufacturer.

B. Product Data: Provide manufacturer's standard catalog pages and data sheets including detailed information on luminaire construction, dimensions, ratings, finishes, mounting requirements, listings, service conditions, photometric performance, installed accessories, and ceiling compatibility; include model number nomenclature clearly marked with all proposed features.

1. LED Luminaires:
 - a. Include estimated useful life, calculated based on IES LM-80 test data.
2. Lamps: Include rated life, color temperature, color rendering index (CRI), and initial and mean lumen output.
3. Fluorescent Emergency Power Supply Unit: Include list of compatible lamp configurations and associated lumen output.

C. Manufacturer's Installation Instructions: Indicate application conditions and limitations of use stipulated by product testing agency. Include instructions for storage, handling, protection, examination, preparation, and installation of product.

D. Operation and Maintenance Data: Instructions for each product including information on replacement parts.

E. Maintenance Materials: Furnish the following for Owner's use in maintenance of project.

1. See Section 016000 - Product Requirements, for additional provisions.
2. Extra Lamps: Ten percent of total quantity installed for each type, but not less than two of each type.
3. Extra Ballasts: Two percent of total quantity installed for each type, but not less than one of each type.

F. Project Record Documents: Record actual connections and locations of luminaires and any associated remote components.

1.6 QUALITY ASSURANCE

A. Comply with requirements of NFPA 70.

1.7 DELIVERY, STORAGE, AND PROTECTION

A. Receive, handle, and store products according to NECA/IESNA 500 (commercial lighting), NECA/IESNA 502 (industrial lighting), and manufacturer's written instructions.

B. Keep products in original manufacturer's packaging and protect from damage until ready for installation.

1.8 FIELD CONDITIONS

A. Maintain field conditions within manufacturer's required service conditions during and after installation.

1.9 WARRANTY

- A. See Section 017800 - Closeout Submittals, for additional warranty requirements.
- B. Provide two year manufacturer warranty for linear fluorescent ballasts.
- C. Provide five year pro-rata warranty for batteries for emergency lighting units.
- D. Provide ten year pro-rata warranty for batteries for self-powered exit signs.
- E. Provide five year full warranty for fluorescent emergency power supply units.

PART 2 PRODUCTS

2.1 LUMINAIRE TYPES

- A. Furnish products as indicated in luminaire schedule included on the drawings.
- B. Substitutions: See Section 016000 - Product Requirements, except where individual luminaire types are designated with substitutions not permitted.

2.2 LUMINAIRES

- A. Provide products that comply with requirements of NFPA 70.
- B. Provide products that are listed and labeled as complying with UL 1598, where applicable.
- C. Provide products listed, classified, and labeled as suitable for the purpose intended.
- D. Unless otherwise indicated, provide complete luminaires including lamp(s) and all sockets, ballasts, reflectors, lenses, housings and other components required to position, energize and protect the lamp and distribute the light.
- E. Unless specifically indicated to be excluded, provide all required conduit, boxes, wiring, connectors, hardware, supports, trims, accessories, etc. as necessary for a complete operating system.
- F. Provide products suitable to withstand normal handling, installation, and service without any damage, distortion, corrosion, fading, discoloring, etc.
- G. Recessed Luminaires:
 - 1. Ceiling Compatibility: Comply with NEMA LE 4.
- H. Fluorescent Luminaires:
 - 1. Provide ballast disconnecting means complying with NFPA 70 where required.
 - 2. Fluorescent Luminaires Controlled by Occupancy Sensors: Provide programmed start ballasts.
 - 3. Fluorescent Luminaires Controlled by Dual-Level Switching: Provide with two ballasts.
- I. LED Luminaires:
 - 1. Components: UL 8750 recognized or listed as applicable.
 - 2. Tested in accordance with IES LM-79 and IES LM-80.
 - 3. LED Estimated Useful Life: Minimum of 50,000 hours at 70 percent lumen maintenance, calculated based on IES LM-80 test data.
- J. Luminaires Mounted in Continuous Rows: Provide quantity of units required for length indicated, with all accessories required for joining and aligning.

2.3 EMERGENCY LIGHTING UNITS

- A. Description: Emergency lighting units complying with NFPA 101 and all applicable state and local codes, and listed and labeled as complying with UL 924.
- B. Operation: Upon interruption of normal power source or brownout condition exceeding 20 percent voltage drop from nominal, solid-state control automatically switches connected lamps to integral battery power for minimum of 90 minutes of rated emergency illumination, and automatically recharges battery upon restoration of normal power source.
- C. Battery:
 - 1. Sealed maintenance-free lead calcium unless otherwise indicated.
 - 2. Size battery to supply all connected lamps, including emergency remote heads where indicated.

- D. Diagnostics: Provide power status indicator light and accessible integral test switch to manually activate emergency operation.
- E. Provide low-voltage disconnect to prevent battery damage from deep discharge.
- F. Self-Diagnostics: Provide units that self-monitor functionality and automatically perform testing required by NFPA 101 where indicated; provide indicator light(s) to report test and diagnostic status.

2.4 EXIT SIGNS

- A. Description: Exit signs complying with NFPA 101 and applicable state and local codes, and listed and labeled as complying with UL 924.
 - 1. Number of Faces: Single- or double-face as indicated or as required for installed location.
 - 2. Directional Arrows: As indicated or as required for installed location.
- B. Self-Powered Exit Signs:
 - 1. Operation: Upon interruption of normal power source or brownout condition exceeding 20 percent voltage drop from nominal, solid-state control automatically switches connected lamps to integral battery power for minimum of 90 minutes of rated emergency illumination, and automatically recharges battery upon restoration of normal power source.
 - 2. Diagnostics: Provide power status indicator light and accessible integral test switch to manually activate emergency operation.
 - 3. Provide low-voltage disconnect to prevent battery damage from deep discharge.
 - 4. Self-Diagnostics: Provide units that self-monitor functionality and automatically perform testing required by NFPA 101 where indicated; provide indicator light(s) to report test and diagnostic status.

2.5 BALLASTS AND DRIVERS

- A. Manufacturers:
 - 1. General Electric Company/GE Lighting; : www.gelighting.com/#sle.
 - 2. OSRAM Sylvania, Inc; _____: www.osram.us/ds/#sle.
 - 3. Philips Lighting Electronics/Advance; : www.advance.philips.com.
 - 4. Substitutions: See Section 016000 - Product Requirements.
 - 5. Manufacturer Limitations: Where possible, for each type of luminaire provide ballasts produced by a single manufacturer.
- B. Ballasts/Drivers - General Requirements:
 - 1. Provide ballasts containing no polychlorinated biphenyls (PCBs).
 - 2. Minimum Efficiency/Efficacy: Provide ballasts complying with all current applicable federal and state ballast efficiency/efficacy standards.
- C. Fluorescent Ballasts:
 - 1. All Fluorescent Ballasts: Unless otherwise indicated, provide high frequency electronic ballasts complying with ANSI C82.11 and listed and labeled as complying with UL 935.
 - a. Input Voltage: Suitable for operation at voltage of connected source, with variation tolerance of plus or minus 10 percent.
 - b. Total Harmonic Distortion: Not greater than 10 percent.
 - c. Power Factor: Not less than 0.95.
 - d. Ballast Factor: Normal ballast factor between 0.85 and 1.15, unless otherwise indicated.
 - e. Thermal Protection: Listed and labeled as UL Class P, with automatic reset for integral thermal protectors.
 - f. Sound Rating: Class A, suitable for average ambient noise level of 20 to 24 decibels.
 - g. Lamp Compatibility: Specifically designed for use with the specified lamp, with no visible flicker.
 - h. Lamp Operating Frequency: Greater than 20 kHz, except as specified below.
 - i. Lamp Current Crest Factor: Not greater than 1.7.
 - j. Lamp Wiring Method:

- 1) Programmed Start Ballasts: Provide parallel or series/parallel wired where available; otherwise series wired is acceptable.
- k. Provide automatic restart capability to restart replaced lamp(s) without requiring resetting of power.
- l. Provide end of lamp life automatic shut down circuitry for T5 and smaller diameter lamp ballasts.
- m. Surge Tolerance: Capable of withstanding characteristic surges according to IEEE C62.41.2, location category A.
- n. Electromagnetic Interference/Radio Frequency Interference (EMI/RFI) Limits: Comply with FCC requirements of 47 CFR 15, for Class A, non-consumer application.
- o. Ballast Marking: Include wiring diagrams with lamp connections.
- 2. Non-Dimming Fluorescent Ballasts:
 - a. Lamp Starting Method:
 - 1) T8 Lamp Ballasts: Programmed start unless otherwise indicated.
 - 2) T5 Lamp Ballasts: Programmed start unless otherwise indicated.
 - 3) Compact Fluorescent Lamp Ballasts: Programmed start unless otherwise indicated.
 - b. Lamp Starting Temperature: Capable of starting standard lamp(s) at a minimum of 0 degrees F, and energy saving lamp(s) at a minimum of 60 degrees F unless otherwise indicated.
- D. Dimmable LED Drivers:
 - 1. Dimming Range: Continuous dimming from 100 percent to five percent relative light output unless dimming capability to lower level is indicated, without flicker.
 - 2. Control Compatibility: Fully compatible with the dimming controls to be installed.

2.6 FLUORESCENT EMERGENCY POWER SUPPLY UNITS

- A. Manufacturers:
 - 1. Iota Engineering, LLC; _____: www.iotaengineering.com/#sle.
 - 2. Philips Emergency Lighting/Bodine; _____: www.bodine.com/#sle.
 - 3. Substitutions: See Section 016000 - Product Requirements.
 - 4. Manufacturer Limitations: Where possible, for each type of luminaire provide fluorescent emergency power supply units produced by a single manufacturer.
- B. Description: Self-contained fluorescent emergency power supply units suitable for use with indicated luminaires, complying with NFPA 101 and all applicable state and local codes, and listed and labeled as complying with UL 924.
- C. Compatibility:
 - 1. Ballasts: Compatible with electronic, standard magnetic, energy saving, and dimming AC ballasts, including those with end of lamp life shutdown circuits.
 - 2. Lamps: Compatible with low-mercury lamps.
- D. Operation: Upon interruption of normal power source, solid-state control automatically switches connected lamp(s) to the fluorescent emergency power supply for minimum of 90 minutes of rated emergency illumination, and automatically recharges battery upon restoration of normal power source.
- E. Battery: Sealed maintenance-free high-temperature nickel cadmium unless otherwise indicated.
- F. Emergency Illumination Output:
 - 1. As indicated in Light Fixture Schedule
- G. Diagnostics: Provide accessible and visible multi-chromatic combination test switch/indicator light to display charge, test, and diagnostic status and to manually activate emergency operation.
- H. Operating Temperature: From 32 degrees F to 122 degrees F unless otherwise indicated or required for the installed location.

2.7 LAMPS

- A. Manufacturers:
 - 1. General Electric Company/GE Lighting; _____: www.gelighting.com/#sle.
 - 2. Osram Sylvania; _____: www.sylvania.com/#sle.

3. Philips Lighting Company; _____: www.lighting.philips.com.
 4. Substitutions: See Section 016000 - Product Requirements.
 5. Manufacturer Limitations: Where possible, provide lamps produced by a single manufacturer.
- B. Lamps - General Requirements:
1. Unless explicitly excluded, provide new, compatible, operable lamps in each luminaire.
 2. Verify compatibility of specified lamps with luminaires to be installed. Where lamps are not specified, provide lamps per luminaire manufacturer's recommendations.
 3. Minimum Efficiency: Provide lamps complying with all current applicable federal and state lamp efficiency standards.
 4. Color Temperature Consistency: Unless otherwise indicated, for each type of lamp furnish products which are consistent in perceived color temperature. Replace lamps that are determined by the Architect to be inconsistent in perceived color temperature.
- C. Incandescent Lamps: Wattage and bulb type as indicated, with base type as required for lighting fixture; 130 V rated.
1. Non-Reflector Type Incandescent Lamps: Inside frosted lamp finish unless otherwise indicated.
- D. Compact Fluorescent Lamps: Wattage and bulb type as indicated, with base type as required for luminaire.
1. Low Mercury Content: Provide lamps that pass the EPA Toxicity Characteristic Leaching Procedure (TCLP) test for characteristic hazardous waste.
 2. Correlated Color Temperature (CCT): 3,000 K unless otherwise indicated.
 3. Color Rendering Index (CRI): Not less than 80.
 4. Average Rated Life: Not less than 10,000 hours for an operating cycle of three hours per start.
- E. Linear Fluorescent Lamps: Wattage and bulb type as indicated, with base type as required for luminaire.
1. Low Mercury Content: Provide lamps that pass the EPA Toxicity Characteristic Leaching Procedure (TCLP) test for characteristic hazardous waste.
 2. T8 Linear Fluorescent Lamps:
 - a. Correlated Color Temperature (CCT): 3,000 K unless otherwise indicated.
 - b. Color Rendering Index (CRI): Not less than 80.
 - c. Average Rated Life: Not less than 20,000 hours for an operating cycle of three hours per start.
 3. T5 Linear Fluorescent Lamps:
 - a. Correlated Color Temperature (CCT): 3,000 K unless otherwise indicated.
 - b. Color Rendering Index (CRI): Not less than 80.
 - c. Average Rated Life: Not less than 20,000 hours for an operating cycle of three hours per start.

2.8 ACCESSORIES

- A. Stems for Suspended Luminaires: Steel tubing, minimum 1/2" size, factory finished to match luminaire or field-painted as directed.
- B. Threaded Rods for Suspended Luminaires: Zinc-plated steel, minimum 1/4" size, field-painted as directed.

PART 3 EXECUTION

3.1 EXAMINATION

- A. Verify that field measurements are as indicated.
- B. Verify that outlet boxes are installed in proper locations and at proper mounting heights and are properly sized to accommodate conductors in accordance with NFPA 70.
- C. Verify that suitable support frames are installed where required.
- D. Verify that branch circuit wiring installation is completed, tested, and ready for connection to luminaires.
- E. Verify that conditions are satisfactory for installation prior to starting work.

3.2 PREPARATION

- A. Provide extension rings to bring outlet boxes flush with finished surface.

B. Clean dirt, debris, plaster, and other foreign materials from outlet boxes.

3.3 INSTALLATION

A. Coordinate locations of outlet boxes provided under Section 260533.16 as required for installation of luminaires provided under this section.

B. Install products in accordance with manufacturer's instructions.

C. Install luminaires securely, in a neat and workmanlike manner, as specified in NECA 500 (commercial lighting) and NECA 502 (industrial lighting).

D. Provide required support and attachment in accordance with Section 260529.

E. Install luminaires plumb and square and aligned with building lines and with adjacent luminaires.

F. Suspended Ceiling Mounted Luminaires:

1. Do not use ceiling tiles to bear weight of luminaires.
2. Do not use ceiling support system to bear weight of luminaires unless ceiling support system is certified as suitable to do so.
3. Secure surface-mounted and recessed luminaires to ceiling support channels or framing members or to building structure.
4. Secure pendant-mounted luminaires to building structure.
5. Secure lay-in luminaires to ceiling support channels using listed safety clips at four corners.
6. In addition to ceiling support wires, provide two galvanized steel safety wire(s), minimum 12 gage, connected from opposing corners of each recessed luminaire to building structure.
7. See appropriate Division 9 section where suspended grid ceiling is specified for additional requirements.

G. Recessed Luminaires:

1. Install trims tight to mounting surface with no visible light leakage.
2. Non-IC Rated Luminaires: Maintain required separation from insulation and combustibile materials according to listing.

H. Suspended Luminaires:

1. Unless otherwise indicated, specified mounting heights are to bottom of luminaire.
2. Install using the suspension method indicated, with support lengths and accessories as required for specified mounting height.
3. Provide minimum of two supports for each luminaire equal to or exceeding 4 feet nominal length, with no more than 4 feet between supports.
4. Install canopies tight to mounting surface.
5. Unless otherwise indicated, support pendants from swivel hangers.

I. Wall-Mounted Luminaires: Unless otherwise indicated, specified mounting heights are to center of luminaire.

J. Install accessories furnished with each luminaire.

K. Bond products and metal accessories to branch circuit equipment grounding conductor.

L. Fluorescent Luminaires Controlled by Dual-Level Switching: Connect such that each switch controls the same corresponding lamps in each luminaire.

M. Emergency Lighting Units:

1. Unless otherwise indicated, connect unit to unswitched power from same circuit feeding normal lighting in same room or area. Bypass local switches, contactors, or other lighting controls.

N. Exit Signs:

1. Unless otherwise indicated, connect unit to unswitched power from same circuit feeding normal lighting in same room or area. Bypass local switches, contactors, or other lighting controls.

O. Fluorescent Emergency Power Supply Units:

1. For field-installed units, install inside luminaire unless otherwise indicated. Where installation inside luminaire is not possible, install on top of luminaire.

2. Unless otherwise indicated, connect unit to unswitched power from same circuit feeding normal ballast(s) in luminaire. Bypass local switches, contactors, or other lighting controls.

P. Install lamps in each luminaire.

Q. Lamp Burn-In: Operate lamps at full output for prescribed period per manufacturer's recommendations prior to use with any dimming controls. Replace lamps that fail prematurely due to improper lamp burn-in.

3.4 FIELD QUALITY CONTROL

A. See Section 014000 - Quality Requirements, for additional requirements.

B. Inspect each product for damage and defects.

C. Operate each luminaire after installation and connection to verify proper operation.

D. Test self-powered exit signs, emergency lighting units, and fluorescent emergency power supply units to verify proper operation upon loss of normal power supply.

E. Correct wiring deficiencies and repair or replace damaged or defective products. Repair or replace excessively noisy ballasts as determined by Architect.

3.5 ADJUSTING

A. Aim and position adjustable luminaires to achieve desired illumination as indicated or as directed by Architect. Secure locking fittings in place.

B. Aim and position adjustable emergency lighting unit lamps to achieve optimum illumination of egress path as required or as directed by Architect or authority having jurisdiction.

C. Exit Signs with Field-Selectable Directional Arrows: Set as indicated or as required to properly designate egress path as directed by Architect or authority having jurisdiction.

3.6 CLEANING

A. Clean surfaces according to NECA 500 (commercial lighting), NECA 502 (industrial lighting), and manufacturer's instructions to remove dirt, fingerprints, paint, or other foreign material and restore finishes to match original factory finish.

3.7 CLOSEOUT ACTIVITIES

A. Just prior to Substantial Completion, replace all lamps that have failed.

3.8 PROTECTION

A. Protect installed luminaires from subsequent construction operations.

END OF SECTION 265100

SECTION 265600
EXTERIOR LIGHTING

PART 1 GENERAL

1.1 SECTION INCLUDES

- A. Exterior luminaires.
- B. Poles and accessories.

1.2 RELATED REQUIREMENTS

- A. Section 033000 - Cast-in-Place Concrete: Materials and installation requirements for concrete bases for poles.
- B. Section 260526 - Grounding and Bonding for Electrical Systems.
- C. Section 260529 - Hangers and Supports for Electrical Systems.
- D. Section 260533.16 - Boxes for Electrical Systems.
- E. Section 260919 - Enclosed Contactors: Lighting contactors.
- F. Section 260923 - Lighting Control Devices: Automatic controls for lighting including outdoor photo controls.

1.3 REFERENCE STANDARDS

- A. ANSI C82.4 - American National Standard for Ballasts for High-Intensity-Discharge and Low-Pressure Sodium Lamps (Multiple-Supply Type); 2002.
- B. IES LM-79 - Approved Method: Electrical and Photometric Measurements of Solid-State Lighting Products; 2008.
- C. IES LM-79 - Approved Method: Electrical and Photometric Measurements of Solid-State Lighting Products; Illuminating Engineering Society; 2008.
- D. IES LM-80 - Approved Method: Measuring Luminous Flux and Color Maintenance of LED Packages, Arrays, and Modules; Illuminating Engineering Society; 2015.
- E. NECA 1 - Standard for Good Workmanship in Electrical Construction; 2010.
- F. NECA/IESNA 501 - Standard for Installing Exterior Lighting Systems; 2006.
- G. NFPA 70 - National Electrical Code; Most Recent Edition Adopted by Authority Having Jurisdiction, Including All Applicable Amendments and Supplements.
- H. UL 1598 - Luminaires; Current Edition, Including All Revisions.
- I. UL 8750 - Light Emitting Diode (LED) Equipment for Use in Lighting Products; Current Edition, Including All Revisions.

1.4 ADMINISTRATIVE REQUIREMENTS

- A. Coordination:
 - 1. Coordinate placement of poles and associated foundations with utilities, curbs, sidewalks, trees, walls, fences, striping, etc. installed under other sections or by others. Coordinate elevation to obtain specified foundation height.
 - 2. Notify Architect of any conflicts or deviations from Contract Documents to obtain direction prior to proceeding with work.

1.5 SUBMITTALS

- A. See Section 013000 - Administrative Requirements, for submittal procedures.
- B. Product Data: Provide manufacturer's standard catalog pages and data sheets including detailed information on luminaire construction, dimensions, ratings, finishes, mounting requirements, listings, service conditions, photometric performance, weight, effective projected area (EPA), and installed accessories; include model number nomenclature clearly marked with all proposed features.
 - 1. LED Luminaires:

- a. Include estimated useful life, calculated based on IES LM-80 test data.
 - 2. Poles: Include information on maximum supported effective projected area (EPA) and weight for the design wind speed.
 - C. Certificates for Poles and Accessories: Manufacturer's documentation that products are suitable for the luminaires to be installed.
 - D. Manufacturer's Installation Instructions: Indicate application conditions and limitations of use stipulated by product testing agency. Include instructions for storage, handling, protection, examination, preparation, installation, and starting of product.
 - E. Operation and Maintenance Data: Instructions for each product including information on replacement parts.
 - F. Maintenance Materials: Furnish the following for Owner's use in maintenance of project.
 - 1. Touch-Up Paint: 2 gallons, to match color of pole finish.
 - G. Project Record Documents: Record actual connections and locations of pole foundations, luminaires, and any pull or junction boxes.
- 1.6 QUALITY ASSURANCE
- A. Comply with requirements of NFPA 70.
- 1.7 DELIVERY, STORAGE, AND HANDLING
- A. Receive, handle, and store products according to NECA/IESNA 501 and manufacturer's written instructions.
 - B. Keep products in original manufacturer's packaging and protect from damage until ready for installation.
- 1.8 WARRANTY
- A. See Section 017800 - Closeout Submittals, for additional warranty requirements.
 - B. Provide five year manufacturer warranty for all LED luminaires, including drivers.

PART 2 PRODUCTS

2.1 LUMINAIRE TYPES

- A. Furnish products as indicated in luminaire schedule included on the drawings.
- B. Substitutions: See Section 016000 - Product Requirements.

2.2 LUMINAIRES

- A. Provide products that comply with requirements of NFPA 70.
- B. Provide products that are listed and labeled as complying with UL 1598, where applicable.
- C. Provide products listed, classified, and labeled as suitable for the purpose intended.
- D. Unless otherwise indicated, provide complete luminaires including lamp(s) and all sockets, ballasts, reflectors, lenses, housings and other components required to position, energize and protect the lamp and distribute the light.
- E. Unless specifically indicated to be excluded, provide all required conduit, boxes, wiring, connectors, hardware, poles, foundations, supports, trims, accessories, etc. as necessary for a complete operating system.
- F. Provide products suitable to withstand normal handling, installation, and service without any damage, distortion, corrosion, fading, discoloring, etc.
- G. Provide luminaires listed and labeled as suitable for wet locations unless otherwise indicated.
- H. LED Luminaires:
 - 1. Components: UL 8750 recognized or listed as applicable.
 - 2. Tested in accordance with IES LM-79 and IES LM-80.
 - 3. LED Estimated Useful Life: Minimum of 50,000 hours at 70 percent lumen maintenance, calculated based on IES LM-80 test data.

2.3 POLES

A. All Poles:

1. Provide poles and associated support components suitable for the luminaire(s) and associated supports and accessories to be installed.
2. Structural Design Criteria:
 - a. Wind Load: Include effective projected area (EPA) of luminaire(s) and associated supports and accessories to be installed.
 - 1) Design Wind Speed: _____ miles per hour, with gust factor of 1.3.
 - b. Dead Load: Include weight of proposed luminaire(s) and associated supports and accessories.
3. Material: Steel, unless otherwise indicated.
4. Shape: Round straight, unless otherwise indicated.
5. Finish: Match luminaire finish, unless otherwise indicated.
6. Mounting: Install on concrete foundation, height as indicated on the drawings, unless otherwise indicated.
7. Unless otherwise indicated, provide with the following features/accessories:
 - a. Top cap.
 - b. Handhole.
 - c. Anchor bolts with leveling nuts or leveling shims.
 - d. Anchor base cover.

B. Metal Poles: Provide ground lug, accessible from handhole.

PART 3 EXECUTION

3.1 EXAMINATION

- A. Verify that field measurements are as indicated.
- B. Verify that outlet boxes are installed in proper locations and at proper mounting heights and are properly sized to accommodate conductors in accordance with NFPA 70.
- C. Verify that suitable support frames are installed where required.
- D. Verify that branch circuit wiring installation is completed, tested, and ready for connection to luminaires.
- E. Verify that conditions are satisfactory for installation prior to starting work.

3.2 PREPARATION

- A. Provide extension rings to bring outlet boxes flush with finished surface.
- B. Clean dirt, debris, plaster, and other foreign materials from outlet boxes.

3.3 INSTALLATION

- A. Coordinate locations of outlet boxes provided under Section 260533.16 as required for installation of luminaires provided under this section.
- B. Install products in accordance with manufacturer's instructions.
- C. Install luminaires in accordance with NECA/IESNA 501.
- D. Provide required support and attachment in accordance with Section 260529.
- E. Install luminaires plumb and square and aligned with building lines and with adjacent luminaires.
- F. Recessed Luminaires:
 1. Install trims tight to mounting surface with no visible light leakage.
- G. Pole-Mounted Luminaires:
 1. Foundation-Mounted Poles:
 - a. Provide cast-in-place concrete foundations for poles as indicated, in accordance with Section 033000.
 - 1) Install anchor bolts plumb per template furnished by pole manufacturer.
 - 2) Position conduits to enter pole shaft.
 - b. Install foundations plumb.

- c. Install poles plumb, using leveling nuts or shims as required to adjust to plumb.
 - d. Tighten anchor bolt nuts to manufacturer's recommended torque.
 - e. Install non-shrink grout between pole anchor base and concrete foundation, leaving small channel for condensation drainage.
 - f. Install anchor base covers as indicated.
2. Grounding:
- a. Bond luminaires, metal accessories, metal poles, and foundation reinforcement to branch circuit equipment grounding conductor.
 - b. Provide supplementary ground rod electrode as specified in Section 260526 at each pole bonded to grounding system as indicated.
3. Install separate service conductors, 12 AWG copper, from each luminaire down to handhole for connection to branch circuit conductors.
- H. Install accessories furnished with each luminaire.
- I. Bond products and metal accessories to branch circuit equipment grounding conductor.
- J. Install lamps in each luminaire.
- 3.4 FIELD QUALITY CONTROL
- A. Inspect each product for damage and defects.
 - B. Operate each luminaire after installation and connection to verify proper operation.
 - C. Correct wiring deficiencies and repair or replace damaged or defective products. Repair or replace excessively noisy ballasts as determined by Architect.
- 3.5 ADJUSTING
- A. Aim and position adjustable luminaires to achieve desired illumination as indicated or as directed by Architect. Secure locking fittings in place.
 - B. Luminaires with Field-Rotatable Optics: Position optics according to manufacturer's instructions to achieve lighting distribution as indicated or as directed by Architect.
- 3.6 CLEANING
- A. Clean surfaces according to NECA/IESNA 501 and manufacturer's instructions to remove dirt, fingerprints, paint, or other foreign material and restore finishes to match original factory finish.
- 3.7 PROTECTION
- A. Protect installed luminaires from subsequent construction operations.

END OF SECTION 265600

SECTION 284600
FIRE DETECTION AND ALARM

PART 1 GENERAL

1.1 SECTION INCLUDES

- A. Fire alarm system design and installation, including all components, wiring, and conduit.
- B. Transmitters for communication with supervising station.
- C. Maintenance of fire alarm system under contract for specified warranty period.

1.2 RELATED REQUIREMENTS

- A. Section 211300 - Fire-Suppression Sprinkler Systems: Supervisory, alarm, and actuating devices installed in sprinkler system.
- B. Section 213000 - Fire Pumps: Supervisory devices.
- C. Section 142010 - Passenger Elevators: Elevator systems monitored and controlled by fire alarm system.

1.3 REFERENCE STANDARDS

- A. 36 CFR 1191 - Americans with Disabilities Act (ADA) Accessibility Guidelines for Buildings and Facilities; Architectural Barriers Act (ABA) Accessibility Guidelines; current edition.
- B. ADA Standards - Americans with Disabilities Act (ADA) Standards for Accessible Design; 2010.
- C. IEEE C62.41.2 - Recommended Practice on Characterization of Surges in Low-Voltage (1000 V and less) AC Power Circuits; 2002 (Cor 1, 2012).
- D. IEEE C62.41 - IEEE Recommended Practice on Surge Voltages in Low-Voltage Power Circuits; 1991 (R1995).
- E. NFPA 70 - National Electrical Code; Most Recent Edition Adopted by Authority Having Jurisdiction, Including All Applicable Amendments and Supplements.
- F. NFPA 72 - National Fire Alarm and Signaling Code; 2016.
- G. NFPA 101 - Life Safety Code; 2015.

1.4 SUBMITTALS

- A. Proposal Documents: Submit the following with cost/time proposal:
 - 1. NFPA 72 "Record of Completion", filled out to the extent known at the time.
 - 2. Manufacturer's detailed data sheet for each control unit, initiating device, and notification appliance.
 - 3. Certification by Contractor that the system design will comply with Contract Documents.
 - 4. Proposed maintenance contract.
- B. Evidence of designer qualifications.
- C. Design Documents: Submit all information required for plan review and permitting by authorities having jurisdiction, including but not limited to floor plans, riser diagrams, and description of operation:
 - 1. Copy (if any) of list of data required by authority having jurisdiction.
 - 2. NFPA 72 "Record of Completion", filled out to the extent known at the time.
 - 3. Clear and concise description of operation, with input/output matrix similar to that shown in NFPA 72 Appendix A-7-5-2.2(9), and complete listing of software required.
 - 4. System zone boundaries and interfaces to fire safety systems.
 - 5. Location of all components, circuits, and raceways; mark components with identifiers used in control unit programming.
 - 6. Circuit layouts; number, size, and type of raceways and conductors; conduit fill calculations; spare capacity calculations; notification appliance circuit voltage drop calculations.
 - 7. List of all devices on each signaling line circuit, with spare capacity indicated.
 - 8. Manufacturer's detailed data sheet for each component, including wiring diagrams, installation instructions, and circuit length limitations.

9. Description of power supplies; if secondary power is by battery include calculations demonstrating adequate battery power.
 10. Certification by either the manufacturer of the control unit or by the manufacturer of each other component that the components are compatible with the control unit.
 11. Certification by the manufacturer of the control unit that the system design complies with Contract Documents.
 12. Certification by Contractor that the system design complies with Contract Documents.
- D. Evidence of installer qualifications.
- E. Inspection and Test Reports:
1. Submit inspection and test plan prior to closeout demonstration.
 2. Submit documentation of satisfactory inspections and tests.
 3. Submit NFPA 72 "Inspection and Test Form," filled out.
- F. Operating and Maintenance Data: Revise and resubmit until acceptable; have one set available during closeout demonstration:
1. Complete set of specified design documents, as approved by authority having jurisdiction.
 2. Additional printed set of project record documents and closeout documents, bound or filed in same manuals.
 3. Contact information for firm that will be providing contract maintenance and trouble call-back service.
 4. List of recommended spare parts, tools, and instruments for testing.
 5. Replacement parts list with current prices, and source of supply.
 6. Detailed troubleshooting guide and large scale input/output matrix.
 7. Preventive maintenance, inspection, and testing schedule complying with NFPA 72; provide printed copy and computer format acceptable to Owner.
 8. Detailed but easy to read explanation of procedures to be taken by non-technical administrative personnel in the event of system trouble, when routine testing is being conducted, for fire drills, and when entering into contracts for remodeling.
- G. Project Record Documents: Have one set available during closeout demonstration:
1. Complete set of floor plans showing actual installed locations of components, conduit, and zones.
 2. "As installed" wiring and schematic diagrams, with final terminal identifications.
 3. "As programmed" operating sequences, including control events by device, updated input/output chart, and voice messages by event.
- H. Closeout Documents:
1. Certification by manufacturer that the system has been installed in compliance with manufacturer's installation requirements, is complete, and is in satisfactory operating condition.
 2. NFPA 72 "Record of Completion", filled out completely and signed by installer and authorized representative of authority having jurisdiction.
 3. Certificate of Occupancy.
 4. Maintenance contract.

1.5 WARRANTY

- A. Provide control panel manufacturer's warranty that system components other than wire and conduit are free from defects and will remain so for 1 year after date of Substantial Completion.
- B. Provide installer's warranty that the installation is free from defects and will remain so for 1 year after date of Substantial Completion.

PART 2 PRODUCTS

2.1 FIRE ALARM SYSTEM

- A. Fire Alarm System: Provide a new automatic fire detection and alarm system:
 1. Provide all components necessary, regardless of whether shown in Contract Documents or not.
 2. Protected Premises: Entire building.

3. Comply with the following; where requirements conflict, order of precedence of requirements is as listed:
 - a. ADA Standards.
 - b. The requirements of the State Fire Marshal.
 - c. The requirements of the local authority having jurisdiction .
 - d. Applicable local codes.
 - e. Contract Documents (drawings and specifications).
 - f. NFPA 101.
 - g. NFPA 72; where the word "should" is used consider that provision mandatory; where conflicts between requirements require deviation from NFPA 72, identify deviations clearly on design documents.
 4. Evacuation Alarm: general evacuation of entire premises.
 5. Hearing Impaired Occupants: Provide visible notification devices in all public areas and in dwelling units.
 6. Low frequency sounders: Provide in all dwelling units.
 7. Master Control Unit (Panel): New, location shown on plans .
 8. Combined Systems: Do not combine fire alarm system with other non-fire systems.
- B. Supervising Stations and Fire Department Connections:
1. Public Fire Department Notification: By remote supervising station.
 2. Remote Supervising Station: UL-listed central station under contract to facility.
 3. Means of Transmission to Remote Supervising Station: Digital alarm communicator transmitter (DACT), 2 telephone lines.
- C. Circuits:
1. Initiating Device Circuits (IDC): Class A, Style D.
 2. Signaling Line Circuits (SLC) : Class A, Style 6.
 3. Notification Appliance Circuits (NAC): Class B, Style Y.
- D. Spare Capacity:
1. Initiating Device Addresses: Minimum 25 percent spare capacity.
 2. Notification Appliance Circuits: Minimum 25 percent spare capacity.
 3. Fire Alarm Control Units: Capable of handling all circuits utilized to capacity without requiring additional components other than plug-in control modules.
- E. Power Sources:
1. Primary: Dedicated branch circuits of the facility power distribution system.
 2. Secondary: Storage batteries.
 3. Capacity: Sufficient to operate entire system for period specified by NFPA 72.
- 2.2 FIRE SAFETY SYSTEMS INTERFACES
- A. Supervision: Provide supervisory signals in accordance with NFPA 72 for the following:
1. Sprinkler water control valves.
 2. Dry-pipe sprinkler system pressure.
- B. Alarm: Provide alarm initiation in accordance with NFPA 72 for the following:
1. Sprinkler water flow.
 2. Smoke and heat detectors.
 3. Manual Pull Stations.
- 2.3 COMPONENTS
- A. General:
1. Provide flush mounted units where installed in finish areas; in unfinished areas, surface mounted unit are acceptable.
 2. Provide legible, permanent labels for each control device, using identification used in operation and maintenance data.

- B. Fire Alarm Control Units: Analog, addressable type; listed, classified, and labeled as suitable for the purpose intended.
- C. Master Control Unit: As specified above.
- D. Remote Annunciators: LCD display; .
- E. Initiating Devices:
 - 1. Addressable Systems:
 - a. Addressable Devices: Individually identifiable by addressable fire alarm control unit.
 - b. Provide suitable addressable interface modules as indicated or as required for connection to conventional (non-addressable) devices and other components that provide a dry closure output.
 - 2. Manual Pull Stations: Dual Action, non-coded, RED with white "FIRE" lettering.
 - 3. Smoke Detectors: Photoelectric, Addressable.
 - 4. Heat Detectors: Fixed temperature and Rate-of-Rise.
 - 5. Addressable Interface Devices.
- F. Notification Appliances:
 - 1. Bells.
 - 2. Horns: Wall mounted, RED with white "FIRE" lettering, Temporal pattern.
 - 3. Strobes: Wall mounted, RED with white "FIRE" lettering, Multi-candela selectable.
 - 4. Horn/Strobes: Wall mounted, RED with white "FIRE" lettering.
- G. Circuit Conductors: Copper; provide 200 feet extra; color code and label.
- H. Surge Protection: In accordance with IEEE C62.41.2 category B combination waveform and NFPA 70; except for optical fiber conductors.
 - 1. Equipment Connected to Alternating Current Circuits: Maximum let through voltage of 350 V(ac), line-to-neutral, and 350 V(ac), line-to-line; do not use fuses.
- I. Locks and Keys: Deliver keys to Owner.
- J. Instruction Charts: Printed instruction chart for operators, showing steps to be taken when a signal is received (normal, alarm, supervisory, and trouble); easily readable from normal operator's station.
 - 1. Frame: Stainless steel or aluminum with polycarbonate or glass cover.
 - 2. Provide one for each control unit where operations are to be performed.
 - 3. Obtain approval of Owner prior to mounting; mount in location acceptable to Owner.
 - 4. Provide extra copy with operation and maintenance data submittal.

PART 3 EXECUTION

3.1 INSTALLATION

- A. Install in accordance with applicable codes, NFPA 72, NFPA 70, and Contract Documents.
- B. Conceal all wiring, conduit, boxes, and supports where installed in finished areas.
- C. Install instruction cards and labels.
- D. Provide one year monitoring service.
- E. Verify location of all devices with Architect prior to installation.

3.2 INSPECTION AND TESTING FOR COMPLETION

- A. Notify Owner 7 days prior to beginning completion inspections and tests.
- B. Notify authorities having jurisdiction and comply with their requirements for scheduling inspections and tests and for observation by their personnel.
- C. Provide the services of the installer's supervisor or person with equivalent qualifications to supervise inspection and testing, correction, and adjustments.
- D. Prepare for testing by ensuring that all work is complete and correct; perform preliminary tests as required.
- E. Provide all tools, software, and supplies required to accomplish inspection and testing.

- F. Perform inspection and testing in accordance with NFPA 72 and requirements of local authorities; document each inspection and test.
- G. Correct defective work, adjust for proper operation, and retest until entire system complies with Contract Documents.

3.3 PERSONNEL INSTRUCTION

- A. Provide the following instruction to designated Owner personnel:
 - 1. Hands-On Instruction: On-site, using operational system.
- B. Administrative: One-hour session(s) covering issues necessary for non-technical administrative staff; classroom:
 - 1. Initial Training: 1 session pre-closeout.
- C. Basic Operation: One-hour sessions for attendant personnel, security officers, and engineering staff; combination of classroom and hands-on:
 - 1. Initial Training: 1 session pre-closeout.
- D. Furnish the services of instructors and teaching aids; have copies of operation and maintenance data available during instruction.

3.4 CLOSEOUT

- A. Closeout Demonstration: Demonstrate proper operation of all functions to Owner.
 - 1. Be prepared to conduct any of the required tests.
 - 2. Have at least one copy of operation and maintenance data, preliminary copy of project record drawings, input/output matrix, and operator instruction chart(s) available during demonstration.
 - 3. Have authorized technical representative of control unit manufacturer present during demonstration.
 - 4. Demonstration may be combined with inspection and testing required by authority having jurisdiction; notify authority having jurisdiction in time to schedule demonstration.
 - 5. Repeat demonstration until successful.
- B. Substantial Completion of the project cannot be achieved until inspection and testing is successful and:
 - 1. Approved operating and maintenance data has been delivered.
 - 2. All aspects of operation have been demonstrated to Owner.
 - 3. Final acceptance of the fire alarm system has been given by authorities having jurisdiction.
 - 4. Occupancy permit has been granted.
 - 5. Specified pre-closeout instruction is complete.

END OF SECTION 284600

