

# USD 307 ELL-SALINE

## SECURE ENTRIES

BROOKVILLE,

24-3432

KANSAS

### REFERENCE LEGEND

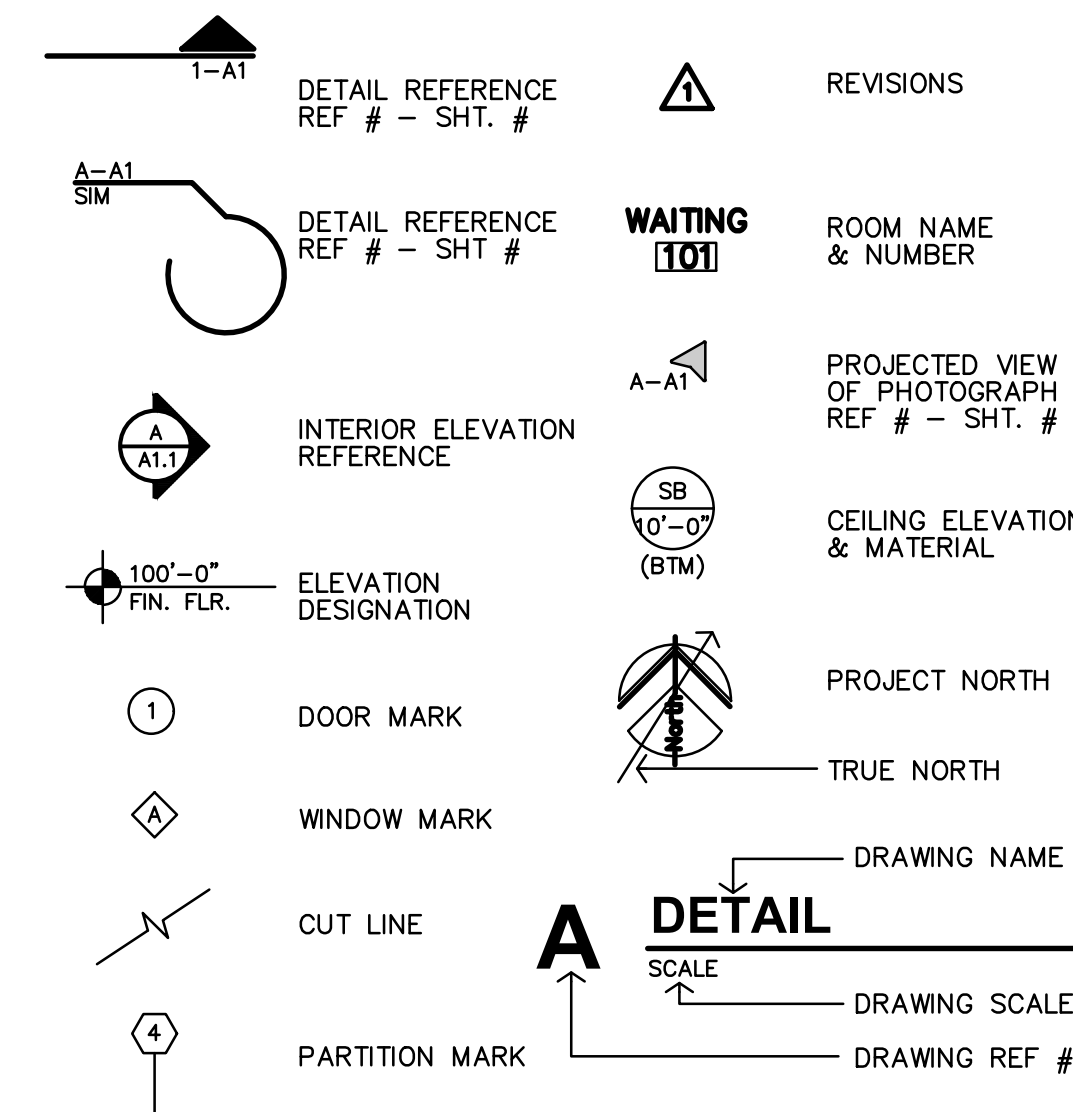

### MATERIAL LEGEND

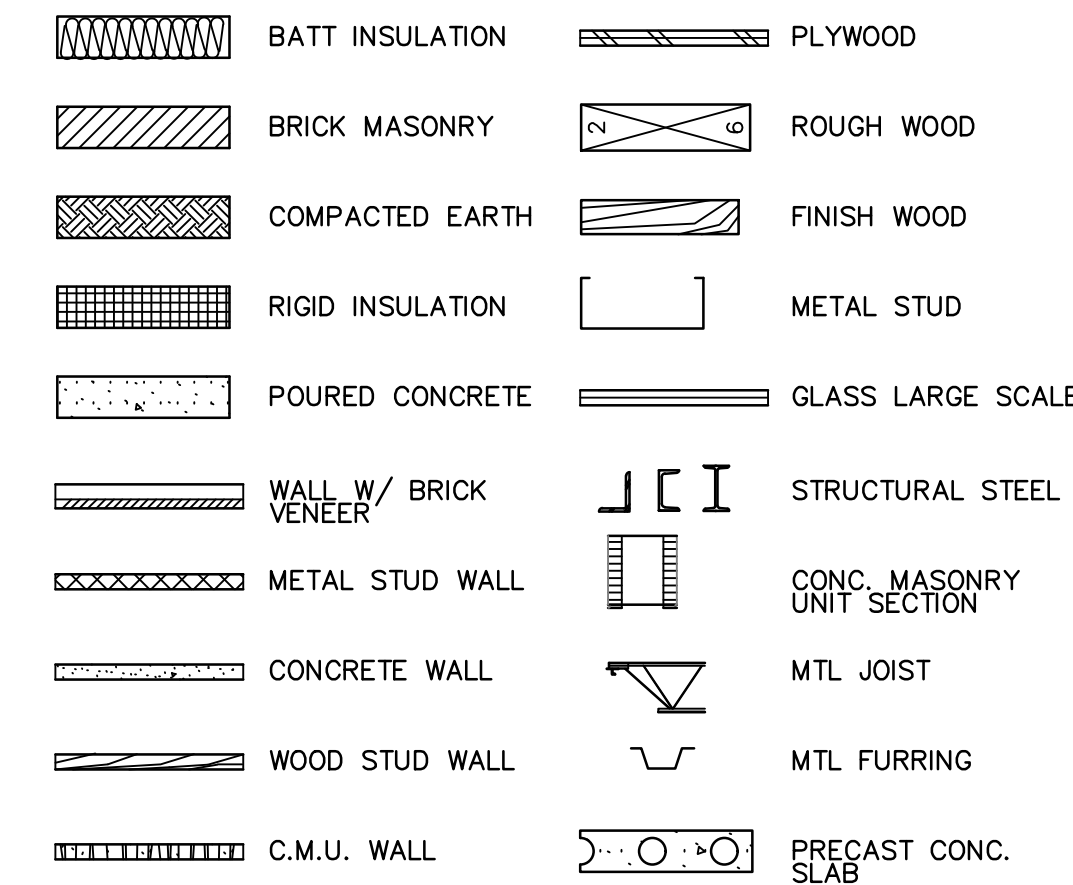

### ABBREVIATIONS

&	AND	Cntr.	Center	Exp.	Expansion	Hr.	Hour	N.I.C.	North	Reinf.	Reinforced	Temp.	Tempered
∠	Angle	Col.	Column	Ext.	Exterior	Hgt.	Height	N.I.C.	Not In Contract	Req'd	Required	T.&G.	Tongue & Groove
AT	At	Conc.	Concrete	F.A.	Fire Alarm	I.D.	Inside Diameter	No. or #	Number	Resil.	Resilient	Thk.	Thick
CL	Centerline	C.T.	Ceramic Tile	F.D.	Fire Alarm	Insul.	Insulation	Nom.	Nominal	Rm.	Room	I.O.M.	Top Of Masonry
Ø	Diameter or Round	CMU	Concrete Masonry Unit	Fdn.	Foundation	Int.	Interior	N.T.S.	Not To Scale	R.O.	Rough Opening	I.D.S.	Top Of Steel
#	Found or Number	Ctr.	Center	F.E.	Fire Extinguisher	Lab.	Laboratory	O/	On or Over	S.	South	I.P.	Top Of Pavement
Acous.	Acoustical	Dbl.	Double	F.E.C.	F.E.C. Cabinet	Lam.	Laminate	Obs.	Obscure	S.B.	South Block	T.P.D.	Toilet Paper Dispenser
Adj.	Adjustable	Det.	Detail	Fin.	Finish	Lav.	Lavatory	O.C.	On Center	S.C.	Solid Core	T.V.	Television
A.F.F.	Above Finished Floor	D.F.	Drinking Fountain	Fl.	Flashing	Lck.	Locker	O.D.	On Diameter	Sched.	Schedule	T.W.	Tackwall
Aggr.	Aggregate	Fl.	Flashing	Flash.	Flashing	Lt.	Light	Off.	Office	S.D.	Soap Dispenser	Typ.	Typical
Al.	Aluminum	Dim.	Dimension	Fl.	Flow line	Lt.	Light	Opp.	Opposite	Shr.	Shower	Trd.	Tread
Approx.	Approximate	Dr.	Down	Ft.	Foot or feet	Lab.	Laboratory	Opng.	Opening	Sect.	Section	U.O.N.	Unless Otherwise Noted
Arch.	Architect or Architectural	Dr.	Door	Ftg.	Footing	Lam.	Laminate	Opp.	Opposite	Sht.	Sheet	Ur.	Urinal
Asb.	Asbestos	Dwg.	Downspout	Furr.	Furring	Lav.	Lavatory	P.	Paint	Sim.	Similar	U.O.N.	Unless Otherwise Noted
Asph.	Asphalt	Dwg.	Downspout	Furr.	Furring	Lck.	Locker	Pi.	Plate	S.N.D.	Sanitary Napkin Disp.	V.C.T.	Vinyl Composition Tile
A.V.	Audio Visual	Dwr.	Drawer	Fut.	Future	Lt.	Light	P.Lam.	Plastic Laminate	S.N.R.	Sanitary Napkin Recep.	V.T.	Vinyl Tile
Bd.	Board	(E)	Existing	Ga.	Gauge	Mas.	Masonry	Plas.	Plaster	Spec.	Specification	V.B.	Vapor Barrier
Bitum.	Bituminous	E.	East or Existing	Galv.	Galvanized	Max.	Maximum	Plywd.	Plywood	Sq.	Square	Vert.	Vertical
Bldg.	Building	Ea.	Each	G.B.	Grab Bar	M.C.	Maximum Cabinet	Pt.	Point	S.S.	Stainless Steel	Vest.	Vestibule
Blk.	Block	E.J.	Expansion Joint	Gl.	Glass	Mech.	Mechanical	P.T.D.	Paper Towel Dispenser	Std.	Standard	Vyl.	Vinyl
Blk'g.	Blocking	El.	Elevation	Gr.	Grade	Memb.	Membrane	P.T.R.	Paper Towel Receptacle	Stl.	Steel	W.	West
Bm.	Beam	Elev.	Elevator	Gyp.	Gypsum	Met.	Metal	Q.T.	Quarry Tile	Str.	Structural	W/o	Without
Bot.	Bottom	Eq.	Equal	H.B.	Hose Bibb	Mfr.	Manufacturer	R.	Riser	Susp.	Suspended	W.C.	Wall Covering
Bot. BY OWNER	Bottom BY OWNER	Eq.	Equipment	H.C.	Hollow Core	Min.	Minimum	Rad.	Radius	Sym.	Symmetrical	Wd.	Wood
Brg.	Bearing	E.W.	Each Way	H.Wd.	Hardware	Mir.	Mirror	R.D.	Roof Drain	Tex.	Texture	Wp.	Waterproof
Brk.	Brick	E.W.C.	Each Water Cooler	H.Wr.	Hardware	Misc.	Miscellaneous	Ref.	Reference	T.B.	Towel Bar	Wdw.	Window
Cab.	Cabinet	Exist.	Existing	H.M.	Hollow Metal	M.O.	Masonry Opening			T.Bd.	Tack Board	Wscot.	Wainscot
Cg.	Ceiling	Expo.	Exposed	Horiz.	Horizontal	Mtd.	Mounted					Wt.	Weight
Cl.	Clear												



730 N. Ninth St. 1881 Main Street, Suite 301  
 Salina, KS 67401 Kansas City, MO 64108  
 785.827.0386 jgr@jgrarchitects.com

### SHEET INDEX

#### GENERAL

ADA ADA DIAGRAMS

#### DEMOLITION

D1.1 DEMOLITION FLOOR & REFLECTED CEILING PLANS: JR-SR HIGH SCHOOL  
 D1.2 DEMOLITION FLOOR & REFLECTED CEILING PLANS: ELEMENTARY SCHOOL  
 D1.3 PHOTOGRAPHS

#### ARCHITECTURAL

A2.1 FLOOR & REFLECTED CEILING PLANS: JR-SR HIGH SCHOOL  
 A2.2 FLOOR & REFLECTED CEILING PLANS: ELEMENTARY SCHOOL  
 A3.1 DOOR SCHEDULE & DETAILS

#### ELECTRICAL

E0.1 ELECTRICAL SPECIFICATIONS & LEGEND  
 E1.1 ELECTRICAL PLAN: JR-SR HIGH SCHOOL  
 E1.2 ELECTRICAL PLANS & SCHEDULE: ELEMENTARY SCHOOL

### CONSULTANTS

Mechanical & Electrical Engineer ;



**LST Consulting Engineers, PA**

4809 Vue Du Lac Place, Suite 301  
 MANHATTAN, KS. 66503  
 ph. (785) 587-8042  
 fax (785) 587-8039  
 mail@LSTengineers.com

PERMIT SET 11-22-2024

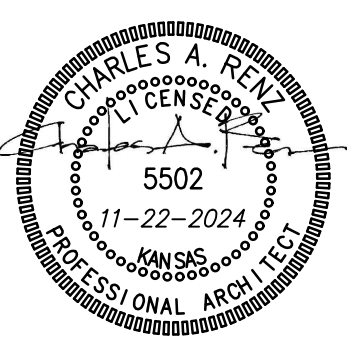

REVISION:  
 DATE: 11-22-2024  
 JOB: 24-3432  
 SHEET NO.:

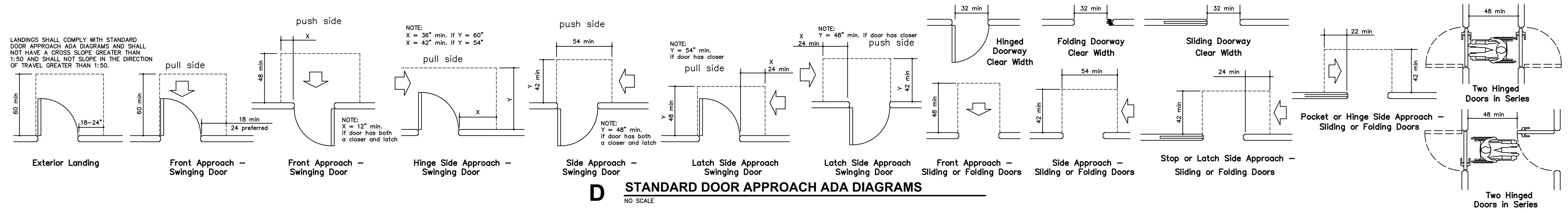

LANDINGS SHALL COMPLY WITH STANDARD DOOR APPROACH ADA DIAGRAMS AND SHALL NOT HAVE A GROSS SLOPE GREATER THAN 1:50 AND SHALL NOT SLOPE IN THE DIRECTION OF TRAVEL GREATER THAN 1:50.

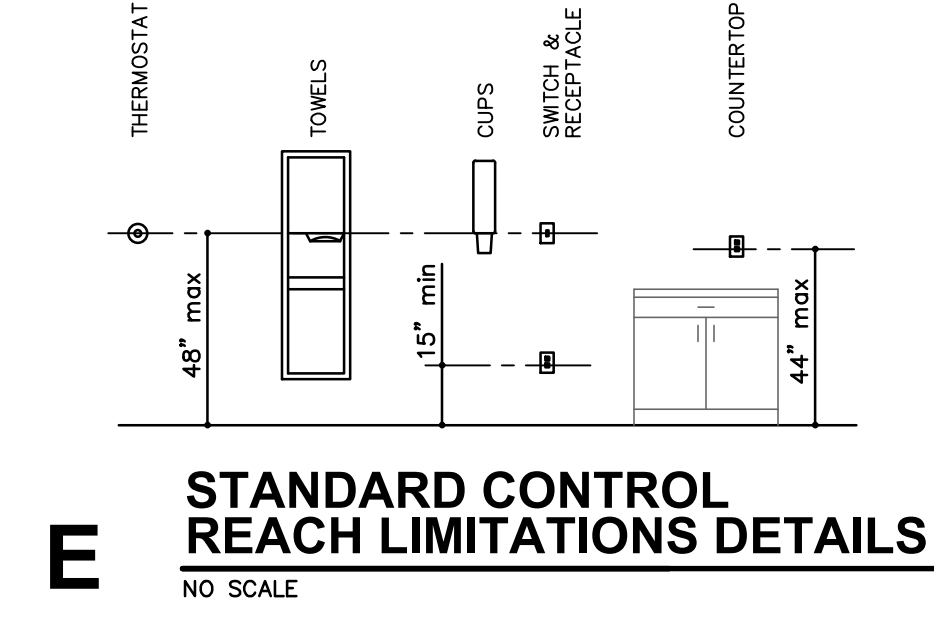
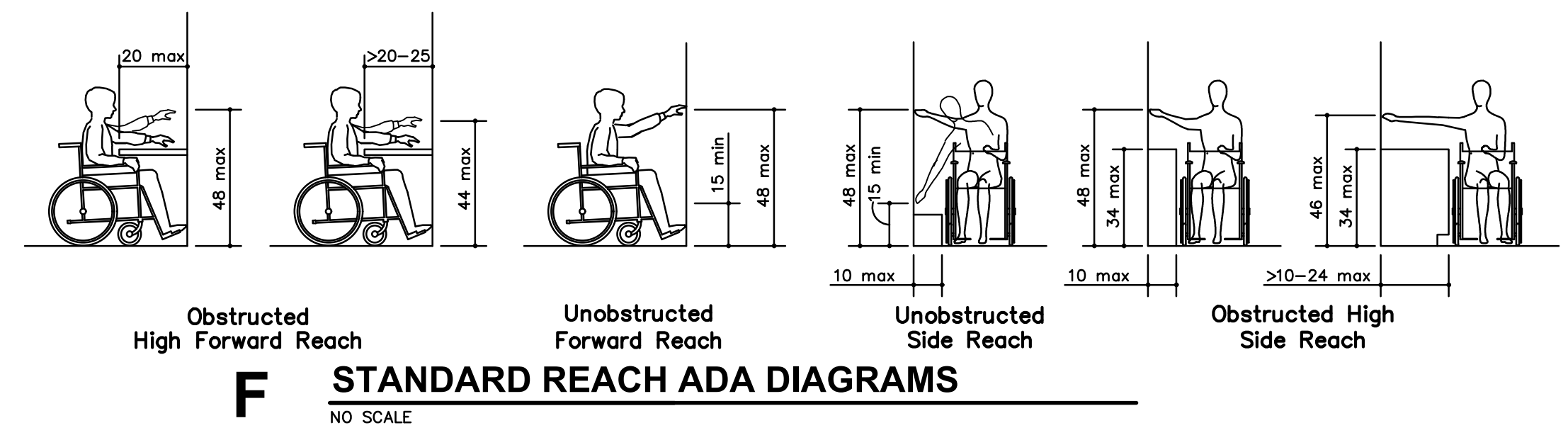
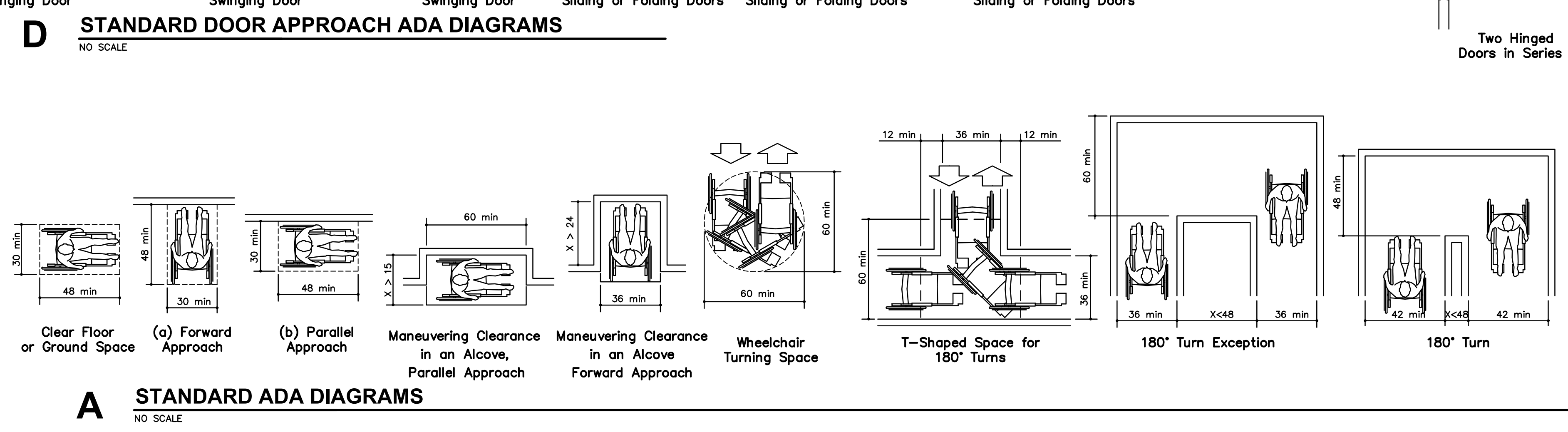
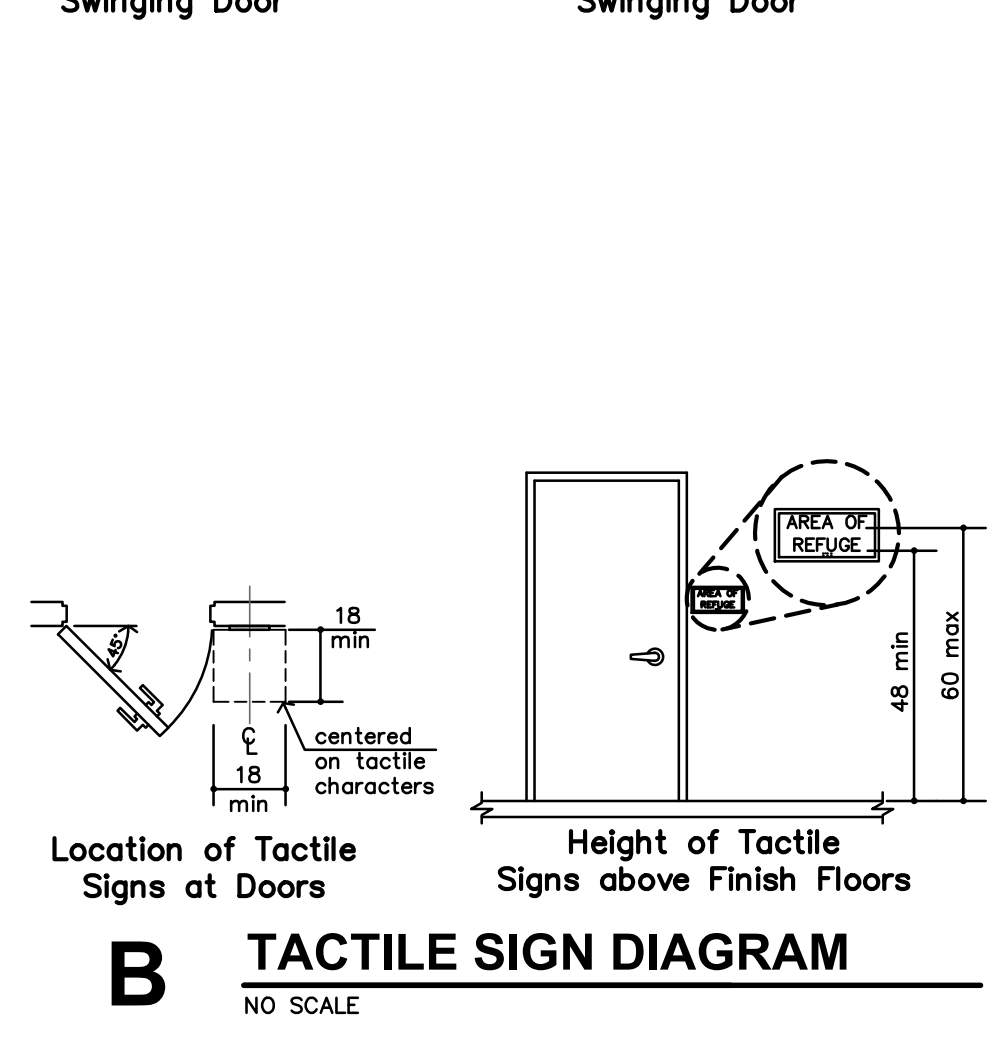
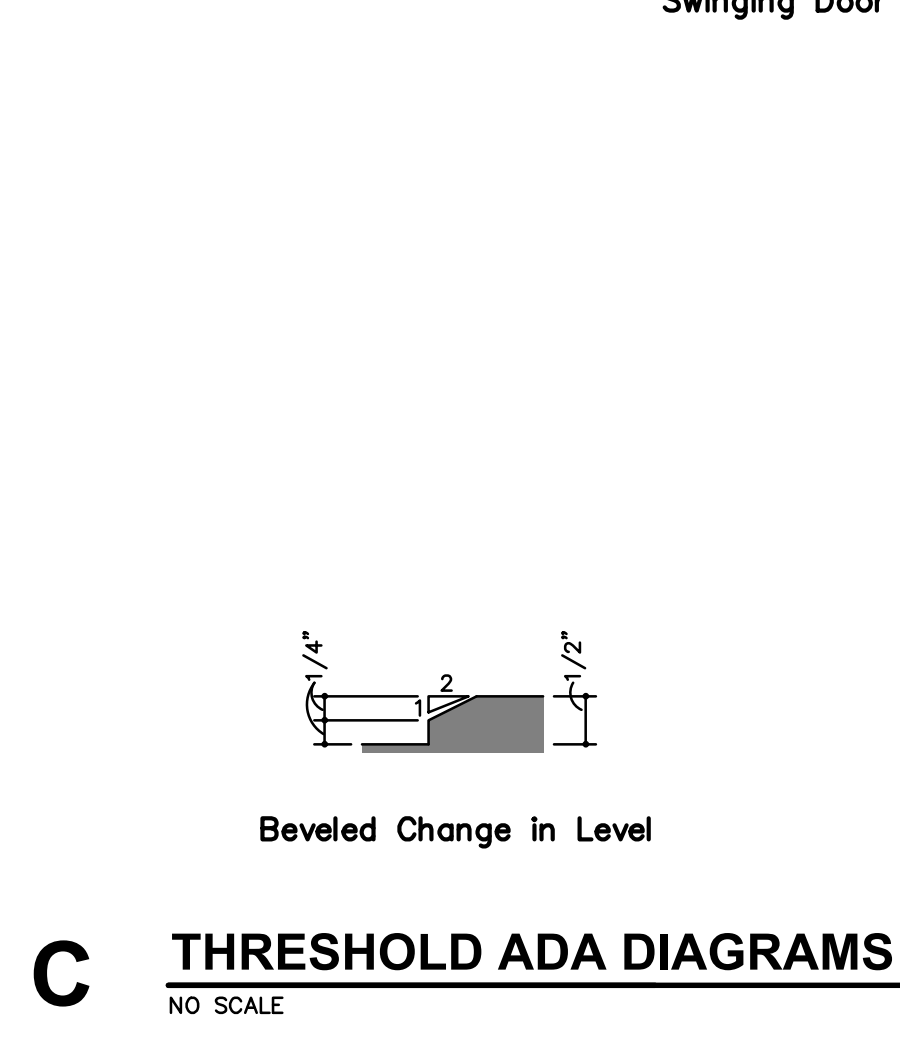

**FOR REFERENCE ONLY**

**NOTES**

PHOTO DESIGNATION  $\blacktriangleleft$ -D2

**GENERAL**

1. WHERE EXIST. BUILDING COMPONENTS ARE TO BE REMOVED; PATCH & REPAIR THE SURFACES TO MATCH EXISTING FINISH, UNLESS NEW FINISHES ARE CALLED FOR; PAINT WALLS CORNER TO CORNER.
2. REMOVE EXISTING BUILDING COMPONENTS AS INDICATED, IMPLIED OR AS REQUIRED SCHEMATICALLY SHOWN AS BOLD DASHED LINES. FIELD VERIFY ALL LOCATIONS.
3. THE ELECTRICAL & MECHANICAL CONTRACTORS SHALL BE RESPONSIBLE FOR ALL CORE DRILLING FOR PIPING & CONDUIT INSTALLATION.
4. ALL OTHER CUTTING, PATCHING & FINISHING, U.N.O. SHALL BE THE RESPONSIBILITY OF THE GENERAL CONTRACTOR.
5. SHORING OF EXISTING STRUCTURE SHALL BE THE RESPONSIBILITY OF THE GENERAL CONTRACTOR.
6. IT SHALL BE THE RESPONSIBILITY OF THE GENERAL CONTRACTOR TO COORDINATE THE DEMOTION BY DIFFERING TRADES.
7. CONTRACTOR TO COORDINATE LOCATIONS OF ANY OF ALL EXISTING RECEPTACLES, SWITCHES, DEVICES, HVAC SYSTEM/COMPONENTS, ETC. PRIOR TO DEMOLITION. SALVAGE, REINSTALL OR DEMOLISH ACCORDINGLY.
8. CONTRACTOR SHALL FIELD VERIFY ALL DIMENSIONS & CONDITIONS.
9. INSTALL MATERIALS AND/OR FINISHES AS INDICATED, IMPLIED OR AS REQUIRED FOR COMPLETE & FINISHED INSTALLATION.
10. ALL WORK SHALL BE IN CONFORMANCE W/ APPLICABLE BUILDING CODES & ORDINANCES.
11. ALL NEW CONSTRUCTION SHALL BE IN CONFORMANCE TO ADA REQUIREMENTS. REFERENCE ADA FOR TYPICAL MINIMUM CLEARANCE REQ.
12. IF THERE IS A DISCREPANCY BETWEEN DRAWINGS AND FIELD CONDITIONS NOTIFY ARCHITECT PRIOR TO PROCEEDING WITH WORK SO THAT ANY ISSUES MAY BE CLARIFIED.

**LEGEND**

NEW MATCHING SUSPENDED CEILING GRID & ACOUSTICAL TILES.



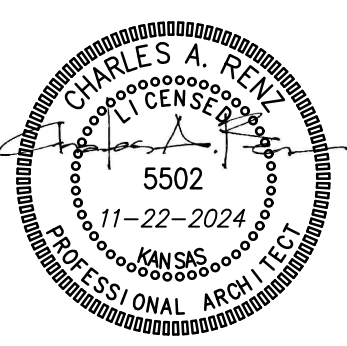
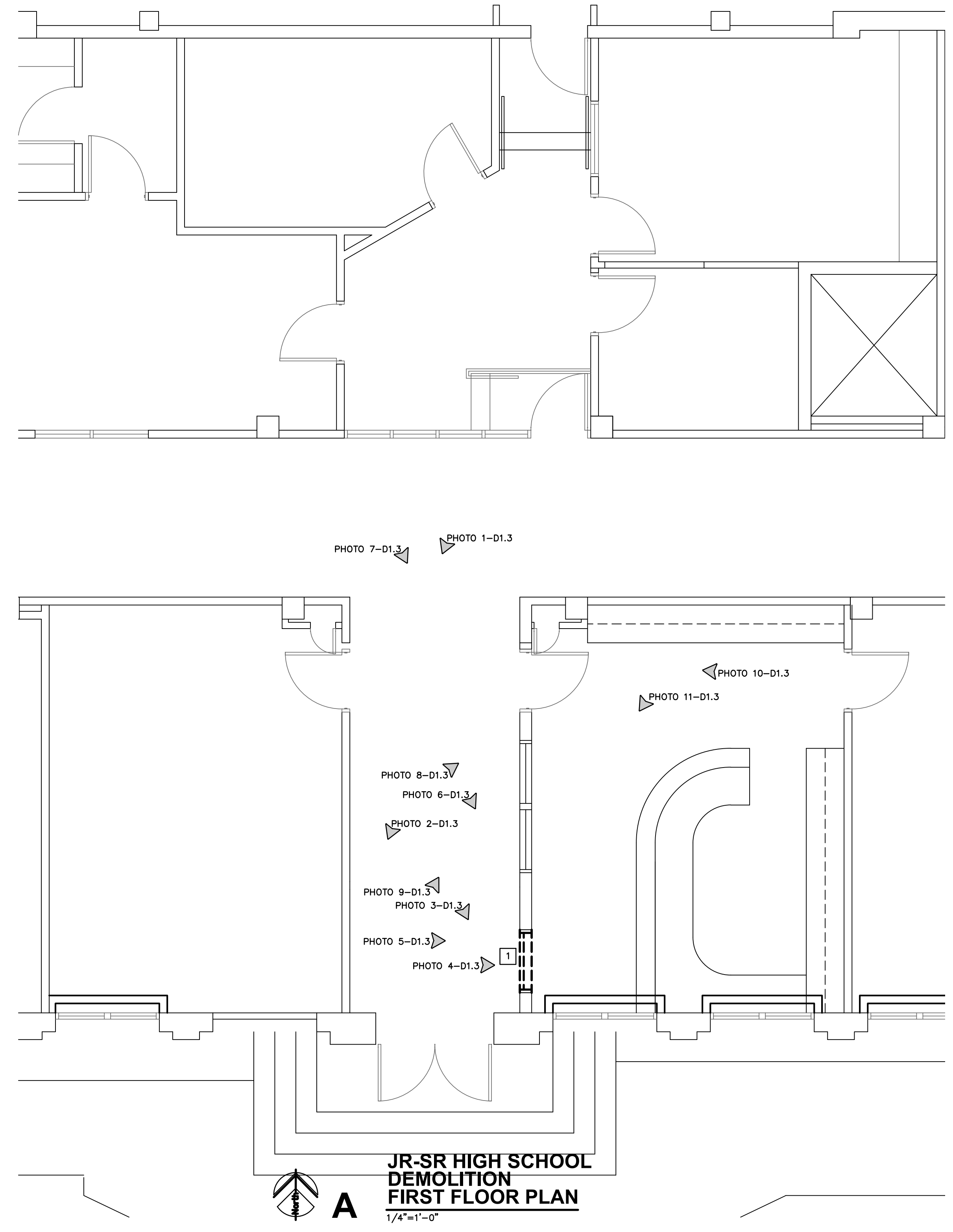
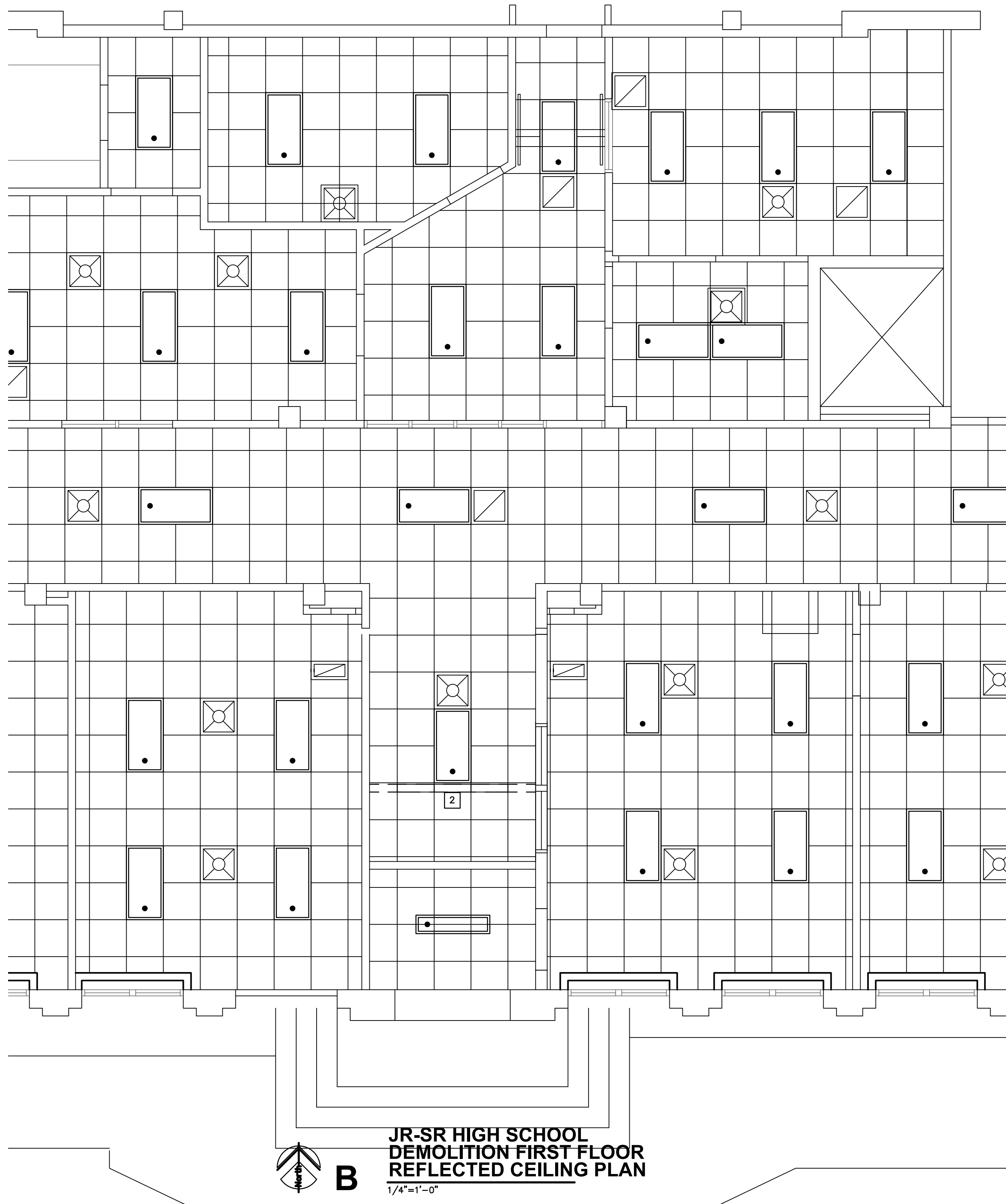

**SPECIFIC NOTES**

- 1 REMOVE EXISTING WINDOW UNIT & ASSOCIATED WALL AREA DIRECTLY BELOW. INSTALL NEW DOOR FRAME & DOOR. INSTALL OWNER-SUPPLIED CARPET TILE AT OPENING AREA.
- 2 TAKE CARE IN CUTTING EXISTING CEILING GRID & ACOUSTICAL TILES, FOR INSTALLATION NEW FULL HEIGHT WALL (5/8" FIRE-RATED MOISTURE RESISTANT G.B., EA. SIDE, OVER 3 5/8" STUDS. CENTER OF NEW WALL SHALL BE CENTERED ON EXISTING WINDOW MULLION. MODIFY CEILING GRID & TILES AS NECESSARY.
- 3 REMOVE GLASS FROM EXISTING WINDOW UNIT. TAKE CARE IN CUTTING OFF SILL & HEAD PORTION OF EXISTING H.M. WINDOW UNIT. SAW-CUT & REMOVE EXISTING CMU BELOW EXISTING WINDOW UNIT FOR INSTALLATION OF NEW DOOR FRAME & DOOR. ANCHOR NEW DOOR FRAME TO EXIST. CMU & GROUT CELLS FULL. NEW DOOR FRAME SHALL ALSO BE CONTINUOUSLY WELDED TO EXISTING WINDOW FRAME (JAMBS & HEAD). INSTALL OWNER-SUPPLIED CARPET TILE AT OPENING AREA.
- 4 TAKE CARE IN REMOVING EXISTING ACOUSTICAL CEILING TILE & RETURN TO OWNER. REMOVE EXISTING DESIGNATED CEILING GRID. TAKE CARE IN REMOVING EXISTING LIGHT FIXTURES FOR REINSTALLATION. REF. ELECTRICAL. INSTALL NEW MATCHING CEILING GRID & ACOUSTICAL TILE.
- 5 REMOVE EXISTING LIGHT COVE, LIGHTS & ASSOCIATED WRING. INSTALL NEW MATCHING CEILING GRID & ACOUSTICAL TILE.
- 6 REMOVE EXISTING ELECTRICAL & DATA FOR EXISTING TV/MONITOR. REF. ELECTRICAL PLANS.
- 7 INSTALL SECURITY FILM ON BOTH SIDES OF EXISTING INTERIOR WINDOWS



REVISION:

DATE:	11-22-2024
JOB:	24-3432
SHEET NO.:	

NOTES	
<p><b>GENERAL</b></p> <ol style="list-style-type: none"> <li>WHERE EXIST. BUILDING COMPONENTS ARE TO BE REMOVED; PATCH &amp; REPAIR THE SURFACES TO MATCH EXISTING FINISH, UNLESS NEW FINISHES ARE CALLED FOR. PAINT WALLS CORNER TO CORNER</li> <li>REMOVE EXISTING BUILDING COMPONENTS AS INDICATED, IMPLIED OR AS REQUIRED SCHEMATICALLY SHOWN AS BOLD DASHED LINES. FIELD VERIFY ALL LOCATIONS</li> <li>THE ELECTRICAL &amp; MECHANICAL CONTRACTORS SHALL BE RESPONSIBLE FOR ALL CORE DRILLING FOR PIPING &amp; CONDUIT INSTALLATION.</li> <li>ALL OTHER CUTTING, PATCHING &amp; FINISHING, U.N.O. SHALL BE THE RESPONSIBILITY OF THE GENERAL CONTRACTOR.</li> <li>SHORING OF EXISTING STRUCTURE SHALL BE THE RESPONSIBILITY OF THE GENERAL CONTRACTOR.</li> <li>IT SHALL BE THE RESPONSIBILITY OF THE GENERAL CONTRACTOR TO COORDINATE THE DEMOLITION BY DIFFERING TRADES.</li> <li>CONTRACTOR TO COORDINATE LOCATIONS OF ANY OF ALL EXISTING RECEPCTACLES, SWITCHES, DEVICES, HVAC SYSTEM/COMPONENTS, ETC. PRIOR TO DEMOLITION. SALVAGE, REINSTALL OR DEMOLISH ACCORDINGLY.</li> <li>CONTRACTOR SHALL FIELD VERIFY ALL DIMENSIONS &amp; CONDITIONS.</li> <li>INSTALL MATERIALS AND/OR FINISHES AS INDICATED, IMPLIED OR AS REQUIRED FOR COMPLETE &amp; FINISHED INSTALLATION.</li> <li>ALL WORK SHALL BE IN CONFORMANCE W/ APPLICABLE BUILDING CODES &amp; ORDINANCES.</li> <li>ALL NEW CONSTRUCTION SHALL BE IN CONFORMANCE TO ADA REQUIREMENTS. REFERENCE ADA FOR TYPICAL MINIMUM CLEARANCE REQ.</li> <li>IF THERE IS A DISCREPANCY BETWEEN DRAWINGS AND FIELD CONDITIONS NOTIFY ARCHITECT PRIOR TO PROCEEDING WITH WORK SO THAT ANY ISSUES MAY BE CLARIFIED.</li> </ol> <p><b>LEGEND</b></p> <p>NEW MATCHING SUSPENDED CEILING GRID &amp; ACOUSTICAL TILES. </p>	<p>PHOTO DESIGNATION -D2</p> <p><b>SPECIFIC NOTES</b></p> <ol style="list-style-type: none"> <li>REMOVE EXISTING WINDOW UNIT &amp; ASSOCIATED WALL AREA DIRECTLY BELOW. INSTALL NEW DOOR FRAME &amp; DOOR. INSTALL OWNER-SUPPLIED CARPET TILE AT OPENING AREA.</li> <li>TAKE CARE IN CUTTING EXISTING CEILING GRID &amp; ACOUSTICAL TILES. FOR INSTALLATION NEW NEW FULL HEIGHT WALL (5/8" FIRE-RATED MOISTURE RESISTANT G.B., EA. SIDE, OVER 3 5/8" STUDS. CENTER OF NEW WALL SHALL BE CENTERED ON EXISTING WINDOW MULLION. MODIFY CEILING GRID &amp; TILES AS NECESSARY.</li> <li>REMOVE GLASS FROM EXISTING WINDOW UNIT. TAKE CARE IN CUTTING OFF SILL &amp; HEAD PORTION OF EXISTING H.M. WINDOW UNIT. SAW-CUT &amp; REMOVE EXISTING CMU BELOW EXISTING WINDOW UNIT FOR INSTALLATION OF NEW DOOR FRAME &amp; DOOR. ANCHOR NEW DOOR FRAME TO EXIST. CMU &amp; GROUT CELLS FULL. NEW DOOR FRAME SHALL ALSO BE CONTINUOUSLY WELDED TO EXISTING WINDOW FRAME (JAMBS &amp; HEAD). INSTALL OWNER-SUPPLIED CARPET TILE AT OPENING AREA.</li> <li>TAKE CARE IN REMOVING EXISTING ACOUSTICAL CEILING TILE &amp; RETURN TO OWNER. REMOVE EXISTING DESIGNATED CEILING GRID. TAKE CARE IN REMOVING EXISTING LIGHT FIXTURES FOR REINSTALLATION. REF. ELECTRICAL.</li> <li>REMOVE EXISTING LIGHT COVE, LIGHTS &amp; ASSOCIATED WIRING. INSTALL NEW MATCHING CEILING GRID &amp; ACOUSTICAL TILE.</li> <li>REMOVE EXISTING ELECTRICAL &amp; DATA FOR EXISTING TV/MONITOR. REF. ELECTRICAL PLANS.</li> <li>INSTALL SECURITY FILM ON BOTH SIDES OF EXISTING INTERIOR WINDOWS</li> </ol>

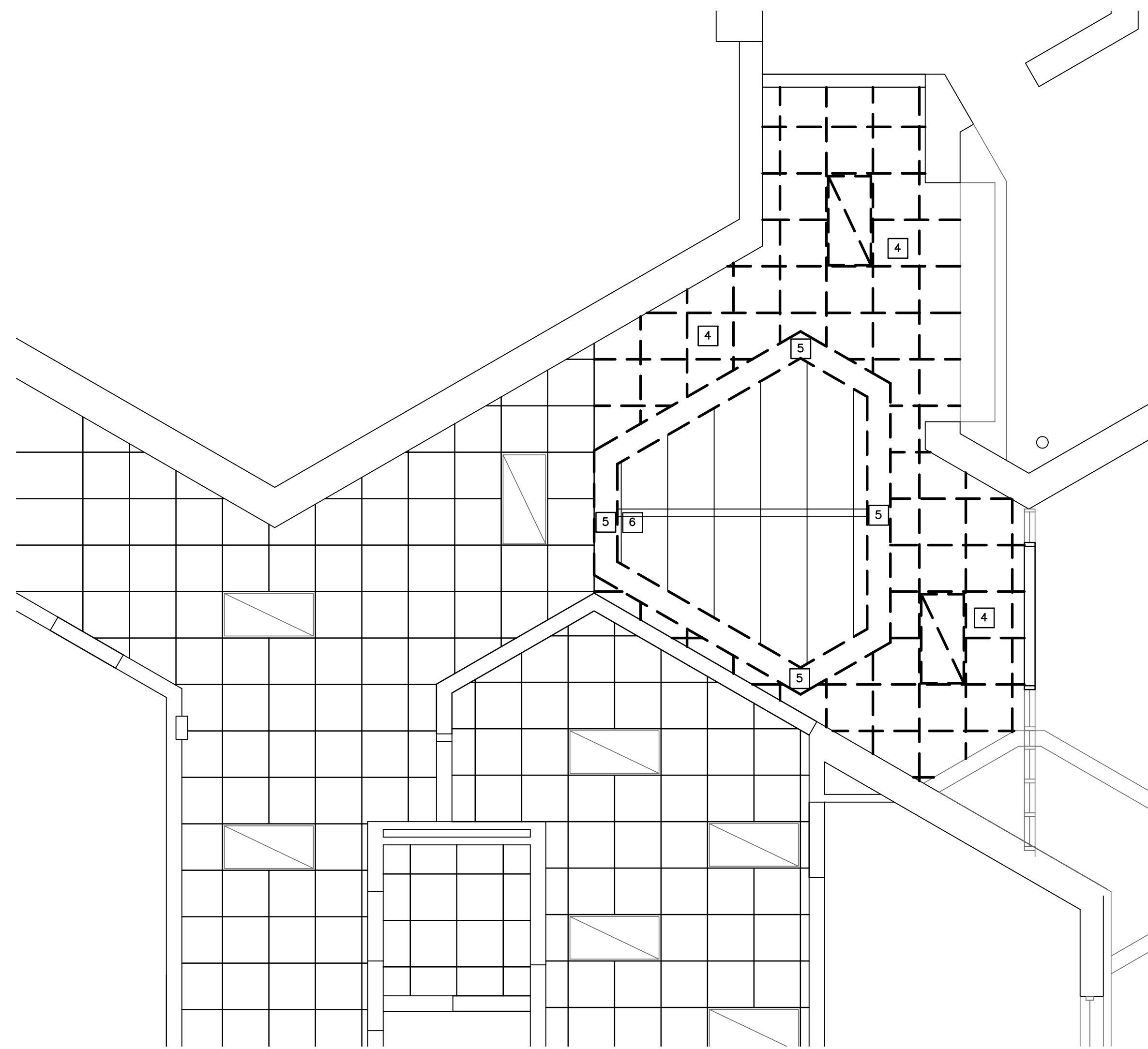

**B** ELEMENTARY SCHOOL  
DEMOLITION FIRST FLOOR  
REFLECTED CEILING PLAN  
1/4"=1'-0"

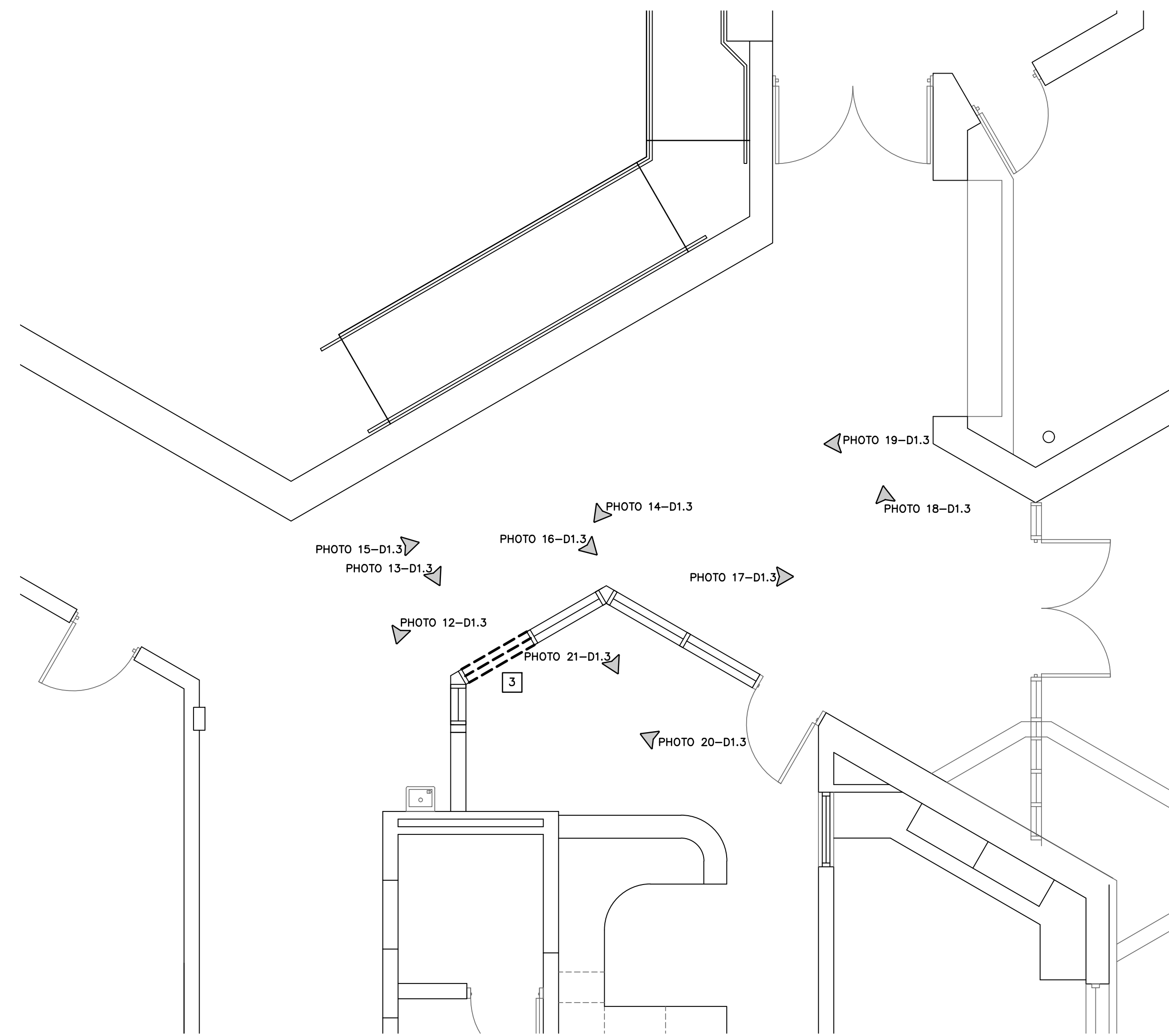

**A** ELEMENTARY SCHOOL  
DEMOLITION  
FIRST FLOOR PLAN  
1/4"=1'-0"

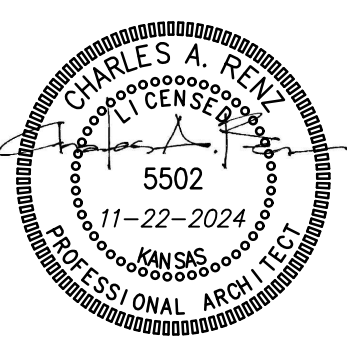

REVISION:	
DATE:	11-22-2024
JOB:	24-3432
SHEET NO.:	

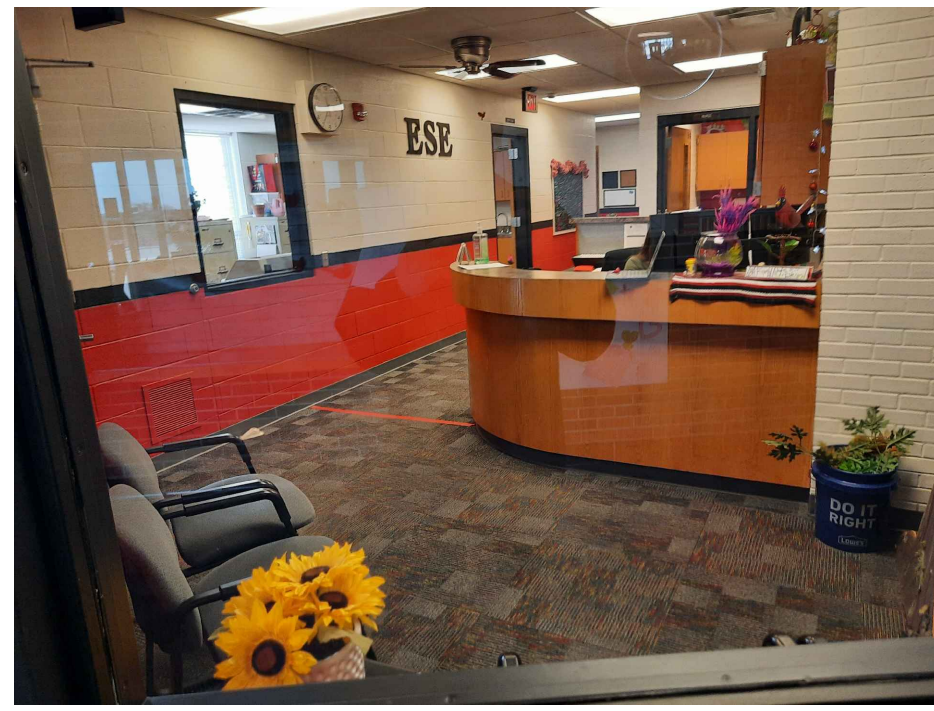

21 PHOTOGRAPH  
NO SCALE

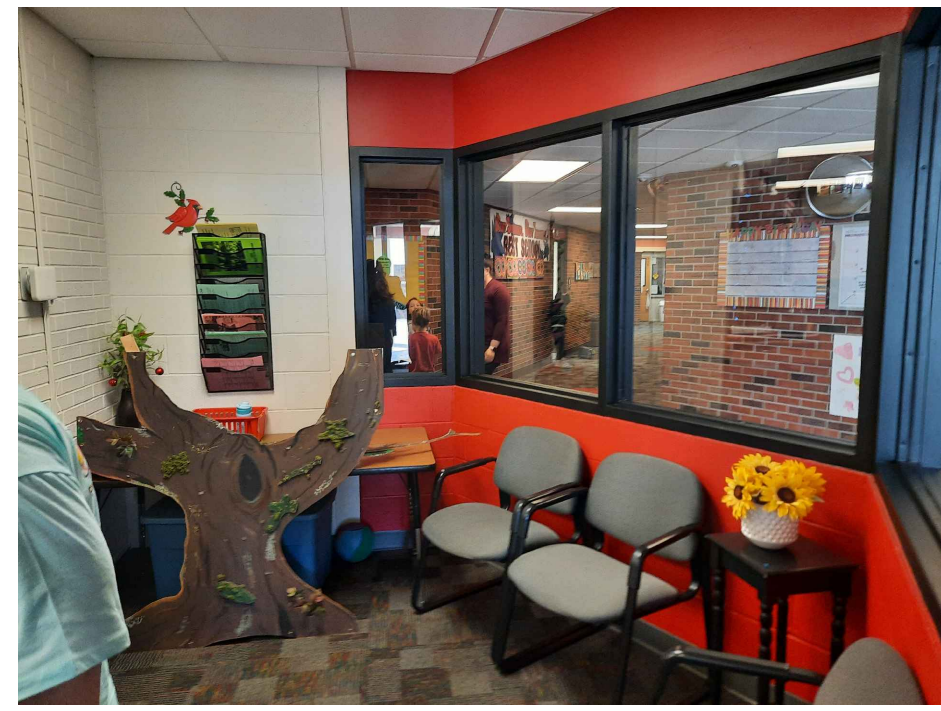

20 PHOTOGRAPH  
NO SCALE

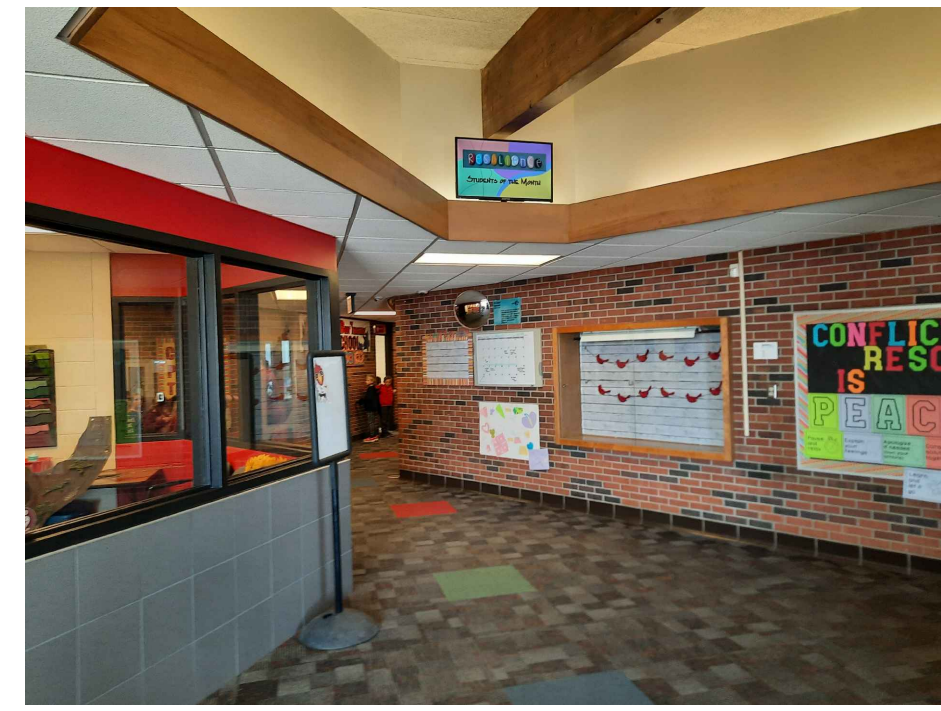

19 PHOTOGRAPH  
NO SCALE



18 PHOTOGRAPH  
NO SCALE

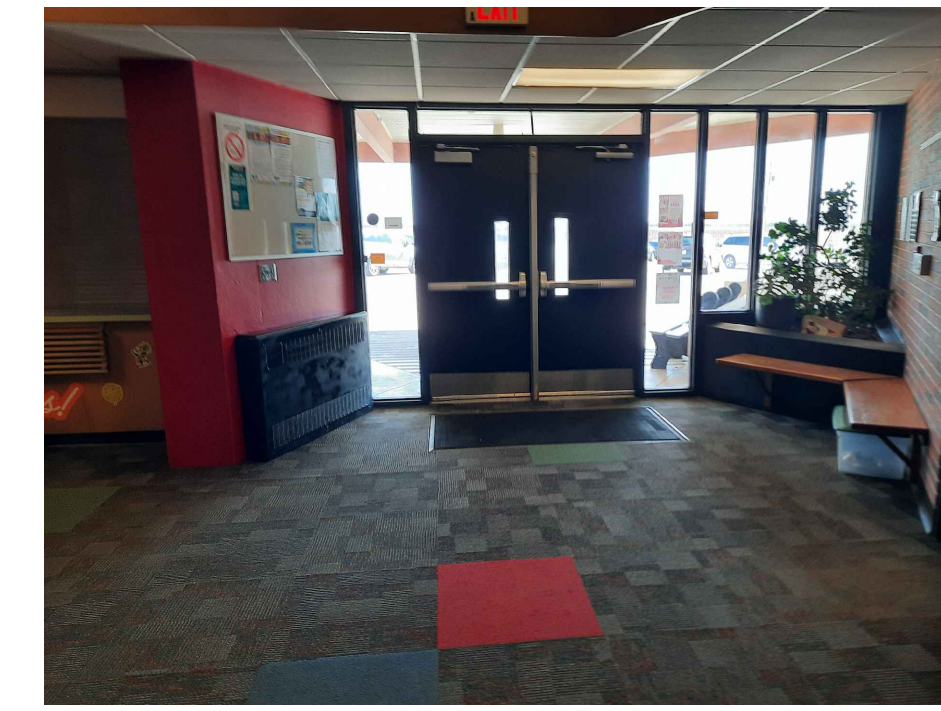

17 PHOTOGRAPH  
NO SCALE

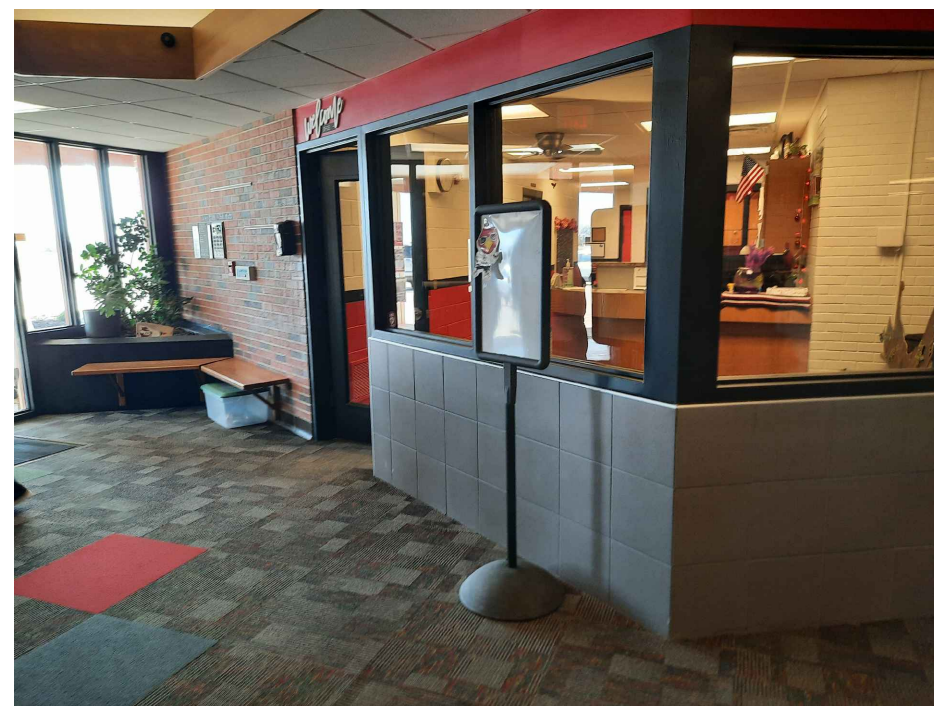

16 PHOTOGRAPH  
NO SCALE



15 PHOTOGRAPH  
NO SCALE

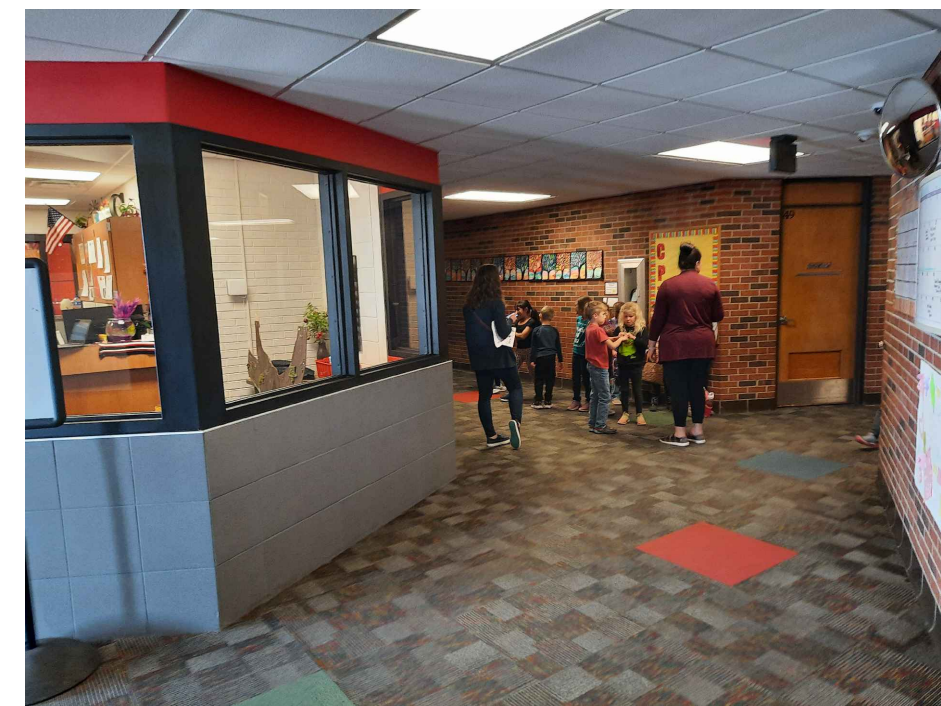

14 PHOTOGRAPH  
NO SCALE

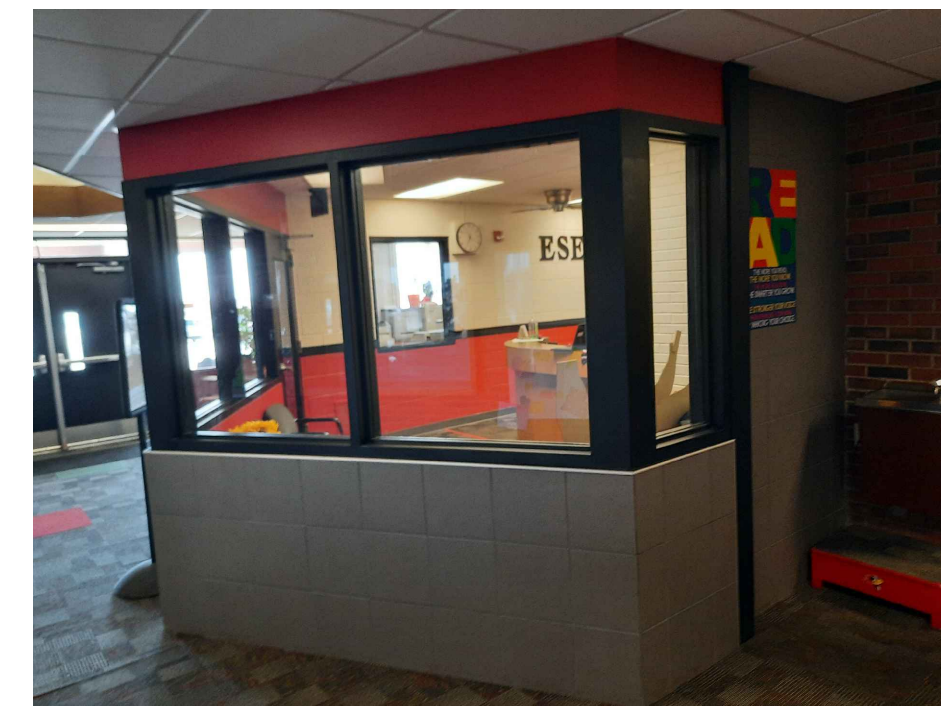

13 PHOTOGRAPH  
NO SCALE

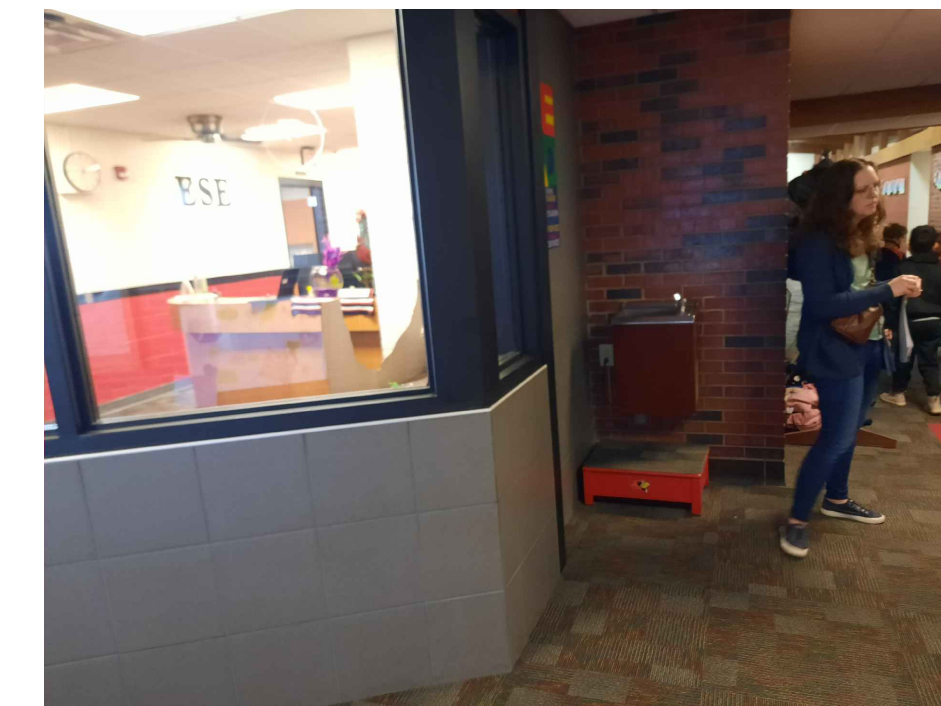

12 PHOTOGRAPH  
NO SCALE



11 PHOTOGRAPH  
NO SCALE

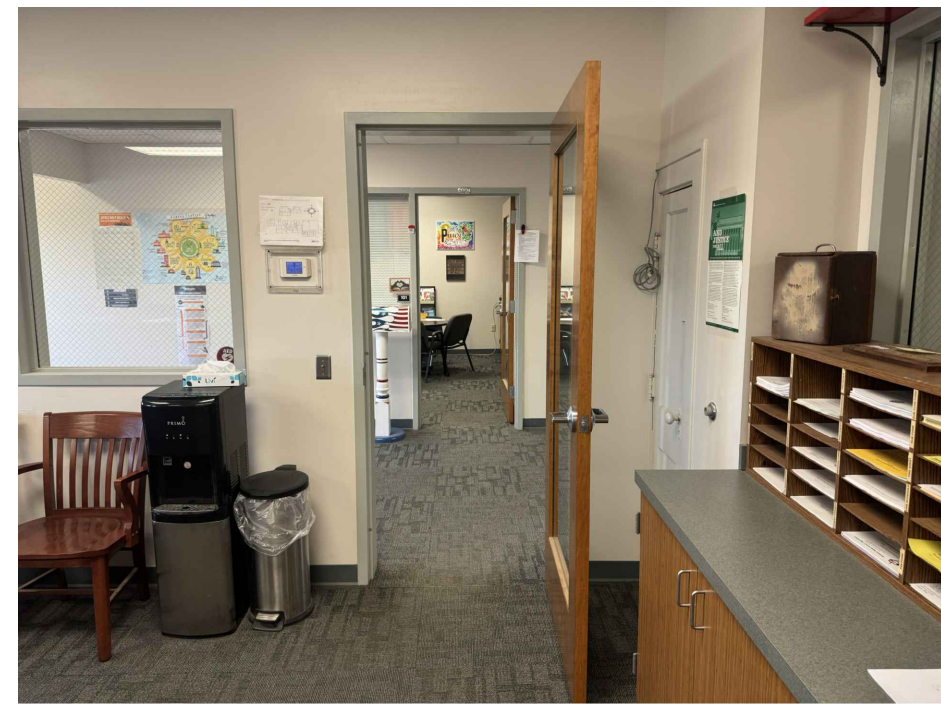

10 PHOTOGRAPH  
NO SCALE

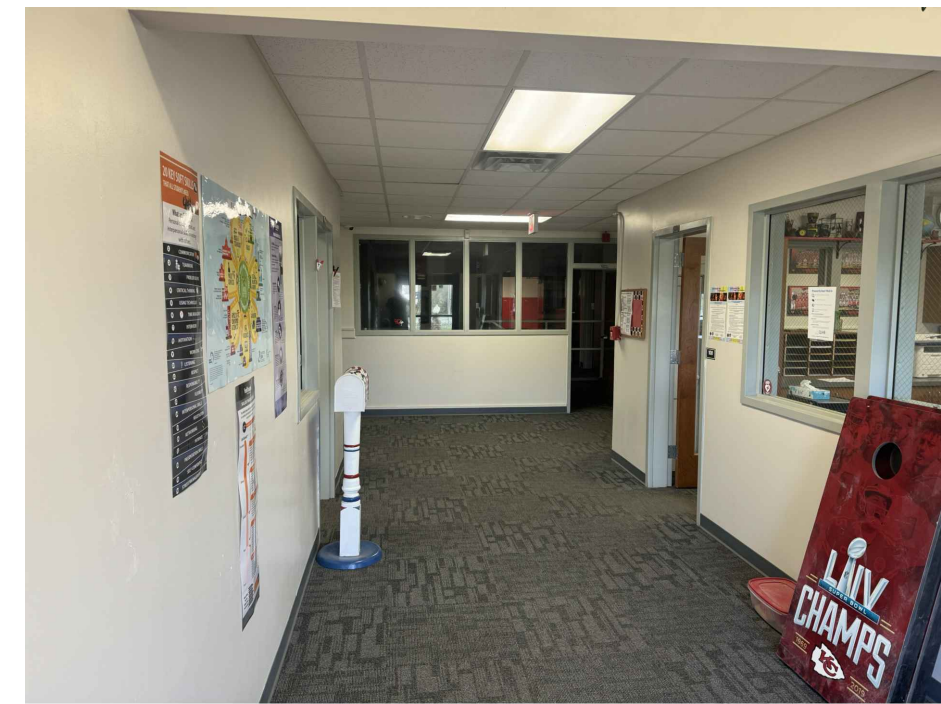

9 PHOTOGRAPH  
NO SCALE



8 PHOTOGRAPH  
NO SCALE



7 PHOTOGRAPH  
NO SCALE



6 PHOTOGRAPH  
NO SCALE

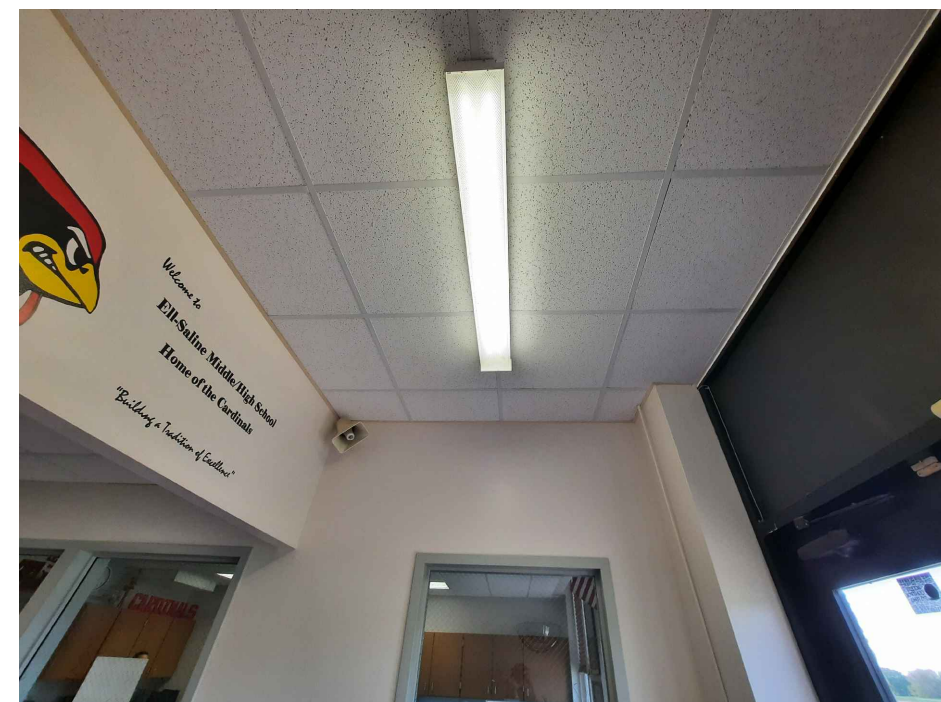

5 PHOTOGRAPH  
NO SCALE

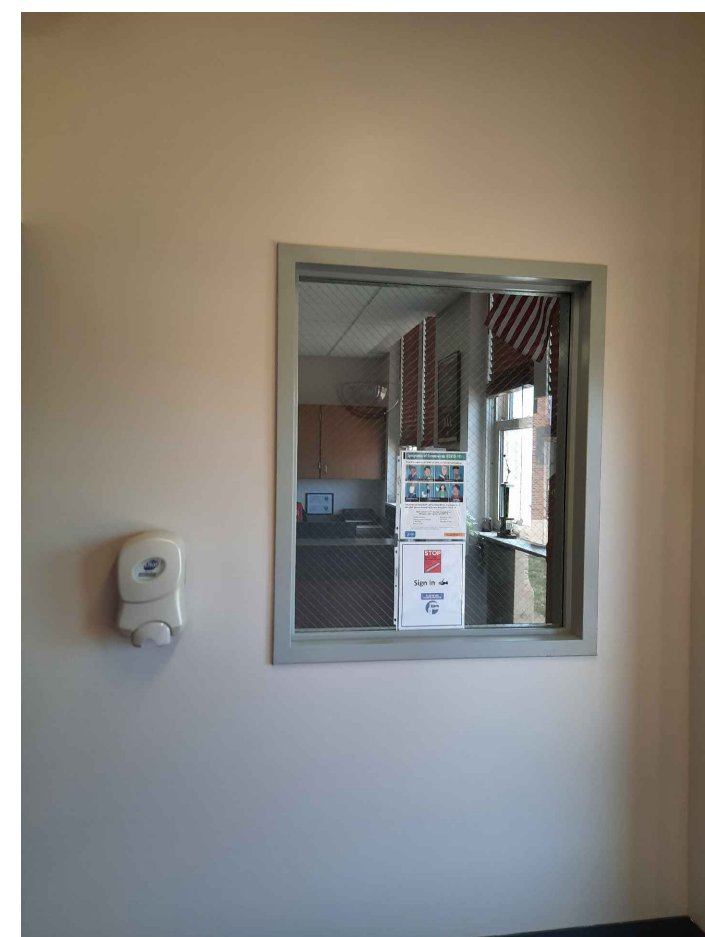

4 PHOTOGRAPH  
NO SCALE

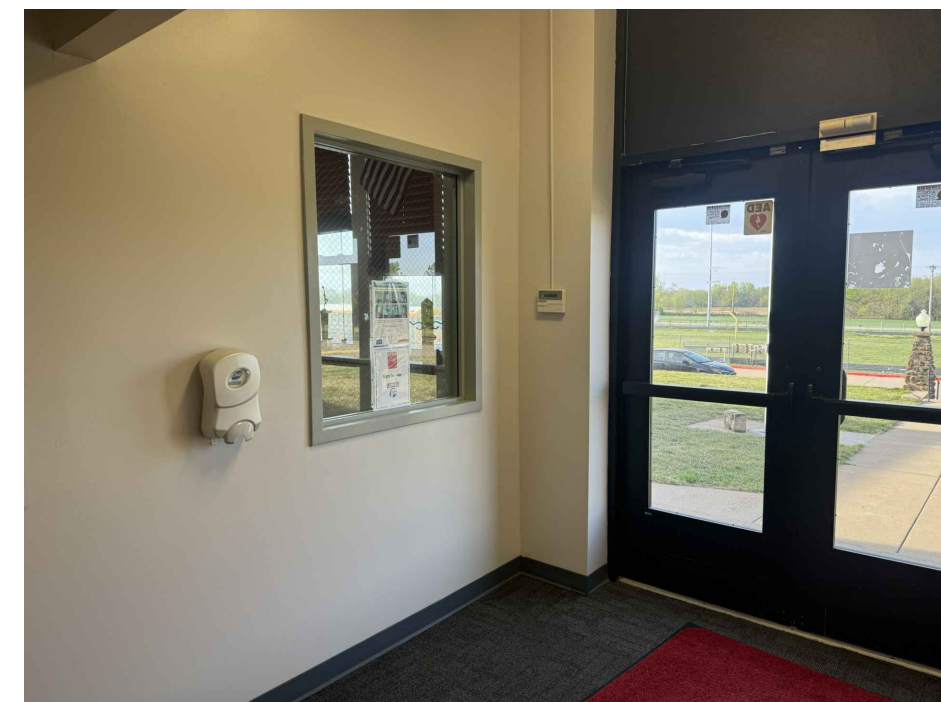

3 PHOTOGRAPH  
NO SCALE

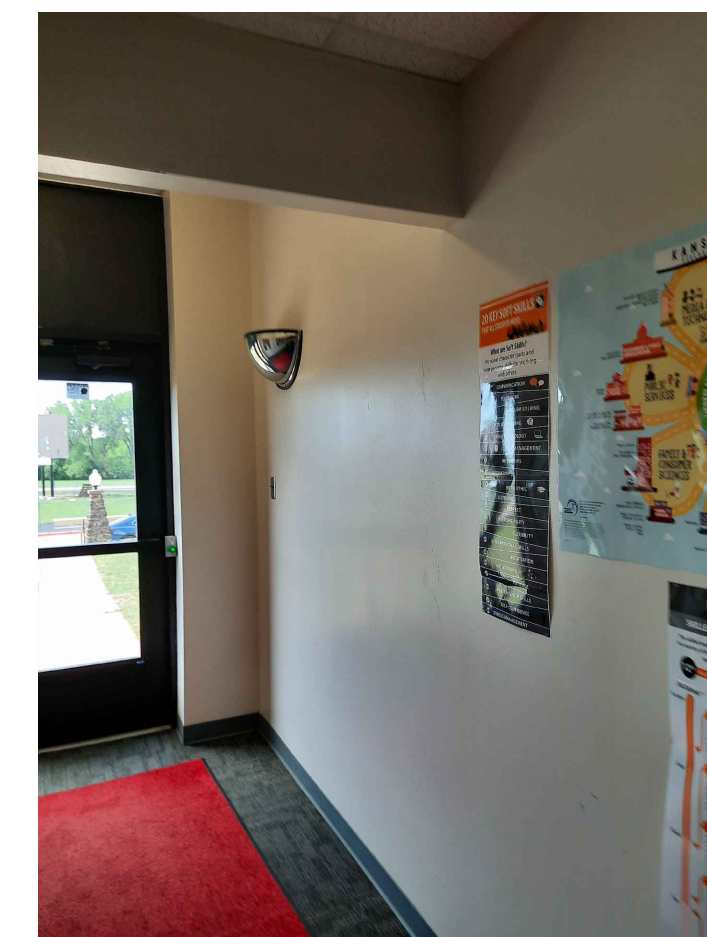

2 PHOTOGRAPH  
NO SCALE



1 PHOTOGRAPH  
NO SCALE

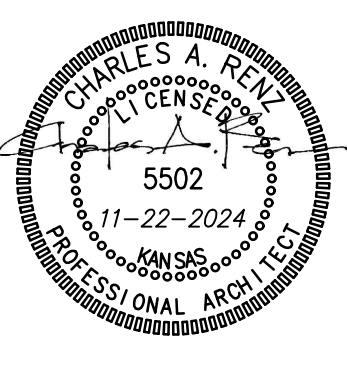

**REFLECTED CEILING PLAN NOTES**

- CONTRACTOR SHALL COORDINATE CEILING LAYOUT WITH MECHANICAL AND ELECTRICAL FIXTURE LOCATIONS. NOTIFY ARCHITECT IMMEDIATELY OF ANY CONFLICT OR DISCREPANCY.
- MECHANICAL/ELECTRICAL FIXTURES @ RATED CEILINGS SHALL BE HUNG IN CONFORMANCE TO U.L. SYSTEM REQUIREMENTS.
- CEILING MOUNTED MECHANICAL EQUIPMENT AND SUSPENDED MECHANICAL EQUIPMENT MUST BE SUSPENDED DIRECTLY FROM THE STRUCTURE.
- WHERE SUSPENSION DEVICES, WIRES, RODS, ETC. PENETRATE CEILING GRID AND/OR TILE OR G.B. PENETRATIONS SHALL BE NEAT AND CLEANLY CUT. PENETRATION OPENING SHALL BE AS SMALL AS POSSIBLE. SEAL AT G.B.
- AT RATED WALLS WHERE EXISTING EQUIPMENT &/OR MATERIALS ARE REMOVED: SEAL VOIDS WITH MATCHING MATERIALS WHERE VISIBLE. WHERE ABOVE CEILING, INSTALL EQUIVALENT RATED MATERIALS, APPROPRIATE U.L. LISTED PILLOWS &/OR FIRE SEALANT.

CEILING TYPES	
REFER SPECIFICATIONS	
1	NEW 2x2 SUSPENDED CEILING SYSTEM
GB	EXISTING GYP. BD. TO REMAIN
E	EXISTING TO REMAIN

1	CLG. TYPE
8'-4"	CLG. HEIGHT

**NOTES**

PHOTO DESIGNATION 1-D2

**GENERAL**

- WHERE EXIST. BUILDING COMPONENTS ARE TO BE REMOVED; PATCH & REPAIR THE SURFACES TO MATCH EXISTING FINISH, UNLESS NEW FINISHES ARE CALLED FOR. PAINT WALLS CORNER TO CORNER.
- REMOVE EXISTING BUILDING COMPONENTS AS INDICATED, IMPLIED OR AS REQUIRED SCHEMATICALLY SHOWN AS BOLD DASHED LINES. FIELD VERIFY ALL LOCATIONS.
- THE ELECTRICAL & MECHANICAL CONTRACTORS SHALL BE RESPONSIBLE FOR ALL CORE DRILLING FOR PIPING & CONDUIT INSTALLATION.
- ALL OTHER CUTTING, PATCHING & FINISHING, U.N.O. SHALL BE THE RESPONSIBILITY OF THE GENERAL CONTRACTOR.
- SHORING OF EXISTING STRUCTURE SHALL BE THE RESPONSIBILITY OF THE GENERAL CONTRACTOR.
- IT SHALL BE THE RESPONSIBILITY OF THE GENERAL CONTRACTOR TO COORDINATE THE DEMOTION BY DIFFERING TRADES.
- CONTRACTOR TO COORDINATE LOCATIONS OF ANY OF ALL EXISTING RECEPABLES, SWITCHES, DEVICES, HVAC SYSTEM/COMPONENTS, ETC. PRIOR TO DEMOLITION. SALVAGE, REINSTALL OR DEMOLISH ACCORDINGLY.
- CONTRACTOR SHALL FIELD VERIFY ALL DIMENSIONS & CONDITIONS.
- INSTALL MATERIALS AND/OR FINISHES AS INDICATED, IMPLIED OR AS REQUIRED FOR COMPLETE & FINISHED INSTALLATION.
- ALL WORK SHALL BE IN CONFORMANCE W/ APPLICABLE BUILDING CODES & ORDINANCES.
- ALL NEW CONSTRUCTION SHALL BE IN CONFORMANCE TO ADA REQUIREMENTS. REFERENCE ADA FOR TYPICAL MINIMUM CLEARANCE REQ.
- IF THERE IS A DISCREPANCY BETWEEN DRAWINGS AND FIELD CONDITIONS NOTIFY ARCHITECT PRIOR TO PROCEEDING WITH WORK SO THAT ANY ISSUES MAY BE CLARIFIED.

**LEGEND**

NEW MATCHING SUSPENDED CEILING GRID & ACOUSTICAL TILES.

**SPECIFIC NOTES**

- REMOVE EXISTING WINDOW UNIT & ASSOCIATED WALL AREA DIRECTLY BELOW. INSTALL NEW DOOR FRAME & DOOR. INSTALL OWNER-SUPPLIED CARPET TILE AT OPENING AREA.
- TAKE CARE IN CUTTING EXISTING CEILING GRID & ACOUSTICAL TILES, FOR INSTALLATION NEW FULL HEIGHT WALL (5/8" FIRE-RATED MOISTURE RESISTANT G.B., EA. SIDE, OVER 3 5/8" STUDS. CENTER OF NEW WALL SHALL BE CENTERED ON EXISTING WINDOW MULLION. MODIFY CEILING GRID & TILES AS NECESSARY.
- REMOVE GLASS FROM EXISTING WINDOW UNIT. TAKE CARE IN CUTTING OFF SILL & HEAD PORTION OF EXISTING H.M. WINDOW UNIT. SAW-CUT & REMOVE EXISTING CMU BELOW EXISTING WINDOW UNIT FOR INSTALLATION OF NEW DOOR FRAME & DOOR. ANCHOR NEW DOOR FRAME TO EXIST. CMU & GROUT CELLS FULL. NEW DOOR FRAME SHALL ALSO BE CONTINUOUSLY WELDED TO EXISTING WINDOW FRAME (JAMBS & HEAD). INSTALL OWNER-SUPPLIED CARPET TILE AT OPENING AREA.
- TAKE CARE IN REMOVING EXISTING ACOUSTICAL CEILING TILE & RETURN TO OWNER. REMOVE EXISTING DESIGNATED CEILING GRID. TAKE CARE IN REMOVING EXISTING LIGHT FIXTURES FOR REINSTALLATION. REF. ELECTRICAL. INSTALL NEW MATCHING CEILING GRID & ACOUSTICAL TILE.
- REMOVE EXISTING LIGHT COVE, LIGHTS & ASSOCIATED WRING. INSTALL NEW MATCHING CEILING GRID & ACOUSTICAL TILE.
- REMOVE EXISTING ELECTRICAL & DATA FOR EXISTING TV/MONITOR. REF. ELECTRICAL PLANS.
- INSTALL SECURITY FILM ON BOTH SIDES OF EXISTING INTERIOR WINDOWS

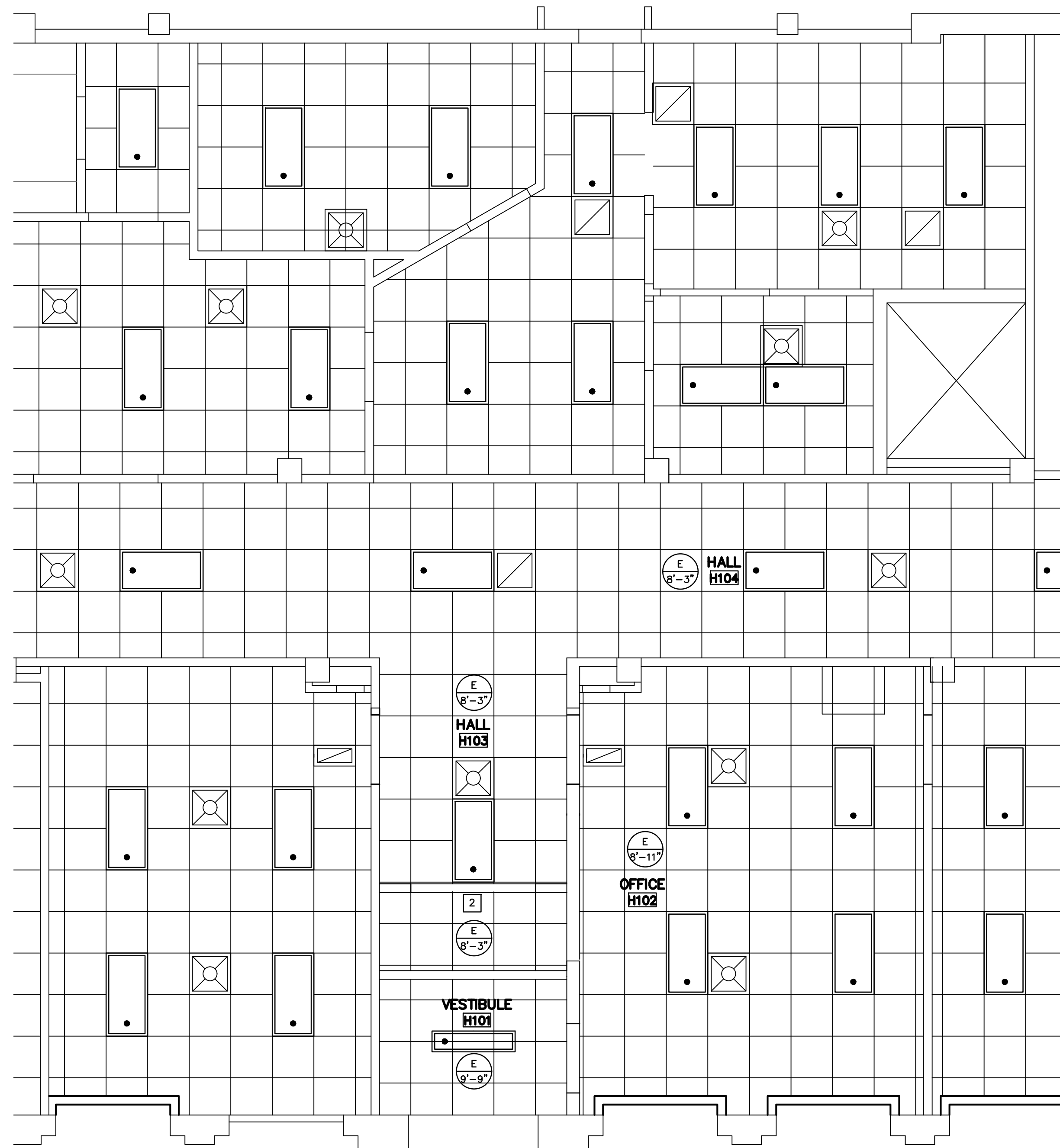

**JR-SR HIGH SCHOOL  
FIRST FLOOR  
REFLECTED CEILING PLAN**  
1/4"=1'-0"

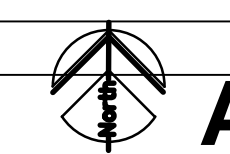
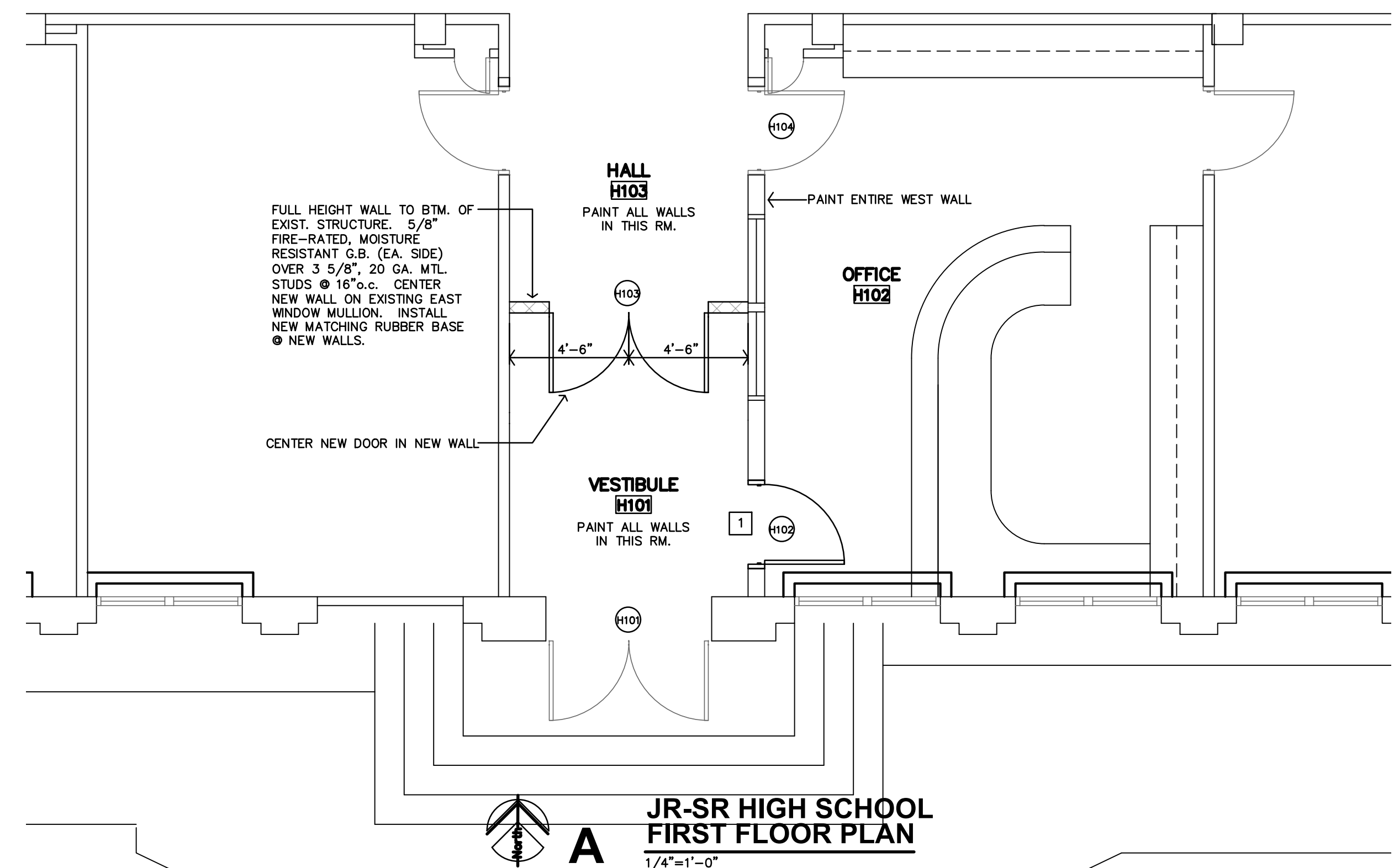
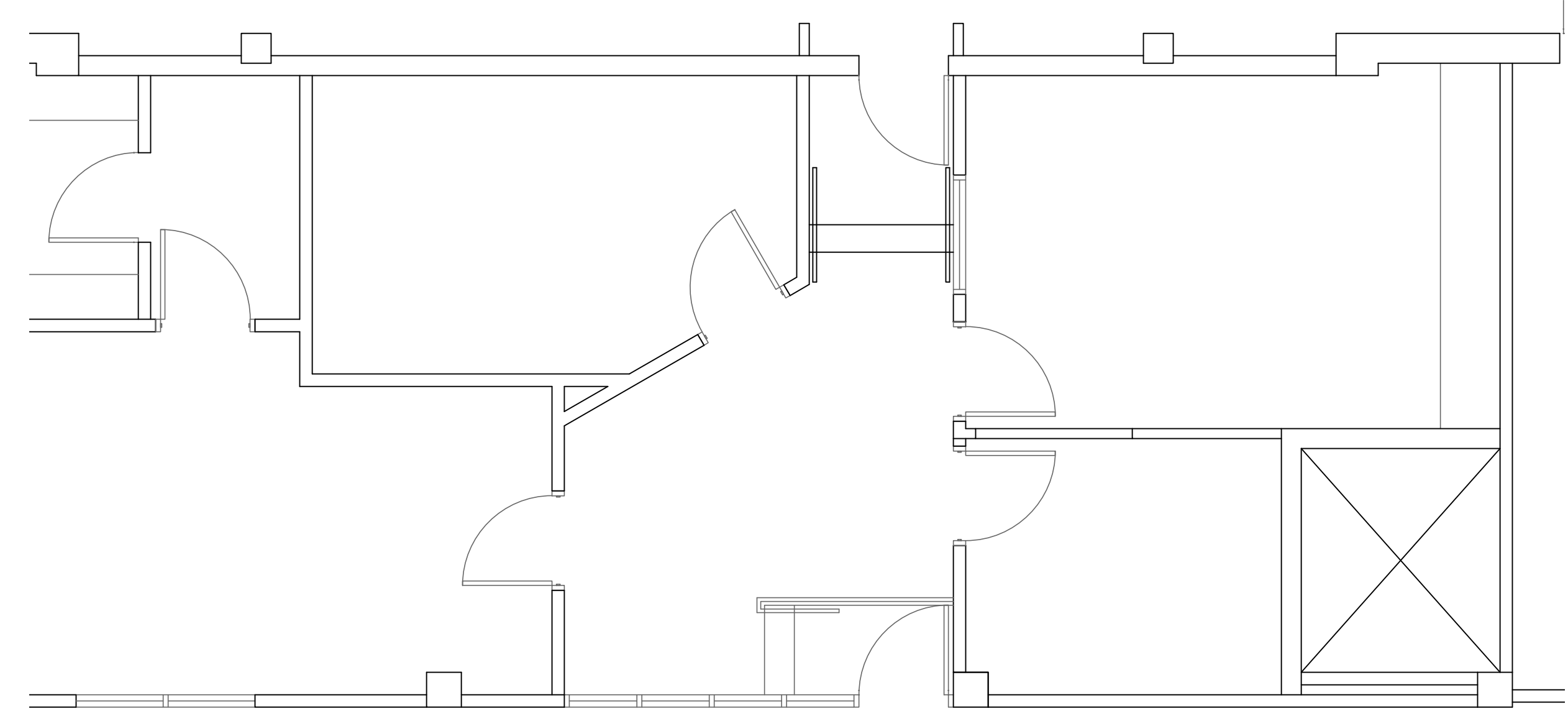

**JR-SR HIGH SCHOOL  
FIRST FLOOR PLAN**  
1/4"=1'-0"

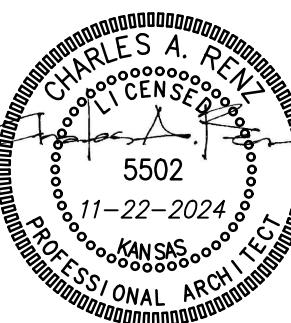

REVISION:

DATE: 11-22-2024

JOB: 24-3432

SHEET NO.:

**REFLECTED CEILING PLAN NOTES**

1. CONTRACTOR SHALL COORDINATE CEILING LAYOUT WITH MECHANICAL AND ELECTRICAL FIXTURE LOCATIONS. NOTIFY ARCHITECT IMMEDIATELY OF ANY CONFLICT OR DISCREPANCY.
2. MECHANICAL/ELECTRICAL FIXTURES @ RATED CEILINGS SHALL BE HUNG IN CONFORMANCE TO U.L. SYSTEM REQUIREMENTS.
3. CEILING MOUNTED MECHANICAL EQUIPMENT AND SUSPENDED MECHANICAL EQUIPMENT MUST BE SUSPENDED DIRECTLY FROM THE STRUCTURE.
4. WHERE SUSPENSION DEVICES, WIRES, RODS, ETC. PENETRATE CEILING GRID AND/OR TILE OR G.B. PENETRATIONS SHALL BE NEAT AND CLEANLY CUT. PENETRATION OPENING SHALL BE AS SMALL AS POSSIBLE. SEAL AT G.B.
5. AT RATED WALLS WHERE EXISTING EQUIPMENT &/OR MATERIALS ARE REMOVED: SEAL VOIDS WITH MATCHING MATERIALS WHERE VISIBLE. WHERE ABOVE CEILING, INSTALL EQUIVALENT RATED MATERIALS, APPROPRIATE U.L. LISTED PILLOWS &/OR FIRE SEALANT.

CEILING TYPES	
REFER SPECIFICATIONS	
1	NEW 2x2 SUSPENDED CEILING SYSTEM
GB	EXISTING GYP. BD. TO REMAIN
E	EXISTING TO REMAIN

1	CLG. TYPE
8'-4"	CLG. HEIGHT

**NOTES**

PHOTO DESIGNATION 1-D2

**GENERAL**

1. WHERE EXIST. BUILDING COMPONENTS ARE TO BE REMOVED, PATCH & REPAIR THE SURFACES TO MATCH EXISTING FINISH, UNLESS NEW FINISHES ARE CALLED FOR. PAINT WALLS CORNER TO CORNER
2. REMOVE EXISTING BUILDING COMPONENTS AS INDICATED, IMPLIED OR AS REQUIRED SCHEMATICALLY SHOWN AS BOLD DASHED LINES. FIELD VERIFY ALL LOCATIONS
3. THE ELECTRICAL & MECHANICAL CONTRACTORS SHALL BE RESPONSIBLE FOR ALL CORE DRILLING FOR PIPING & CONDUIT INSTALLATION.
4. ALL OTHER CUTTING, PATCHING & FINISHING, U.N.O. SHALL BE THE RESPONSIBILITY OF THE GENERAL CONTRACTOR.
5. SHORING OF EXISTING STRUCTURE SHALL BE THE RESPONSIBILITY OF THE GENERAL CONTRACTOR.
6. IT SHALL BE THE RESPONSIBILITY OF THE GENERAL CONTRACTOR TO COORDINATE THE DEMOTION BY DIFFERING TRADES.
7. CONTRACTOR TO COORDINATE LOCATIONS OF ANY OF ALL EXISTING EXISTING RECEPTACLES, SWITCHES, DEVICES, HVAC SYSTEM/COMPONENTS, ETC. PRIOR TO DEMOLITION. SALVAGE, REINSTALL OR DEMOLISH ACCORDINGLY.
8. CONTRACTOR SHALL FIELD VERIFY ALL DIMENSIONS & CONDITIONS.
9. INSTALL MATERIALS AND/OR FINISHES AS INDICATED, IMPLIED OR AS REQUIRED FOR COMPLETE & FINISHED INSTALLATION.
10. ALL WORK SHALL BE IN CONFORMANCE W/ APPLICABLE BUILDING CODES & ORDINANCES.
11. ALL NEW CONSTRUCTION SHALL BE IN CONFORMANCE TO ADA REQUIREMENTS. REFERENCE ADA FOR TYPICAL MINIMUM CLEARANCE REQ.
12. IF THERE IS A DISCREPANCY BETWEEN DRAWINGS AND FIELD CONDITIONS NOTIFY ARCHITECT PRIOR TO PROCEEDING WITH WORK SO THAT ANY ISSUES MAY BE CLARIFIED.

**LEGEND**

NEW MATCHING SUSPENDED CEILING GRID & ACOUSTICAL TILES.

**SPECIFIC NOTES**

1. REMOVE EXISTING WINDOW UNIT & ASSOCIATED WALL AREA DIRECTLY BELOW. INSTALL NEW DOOR FRAME & DOOR. INSTALL OWNER-SUPPLIED CARPET TILE AT OPENING AREA.
2. TAKE CARE IN CUTTING EXISTING CEILING GRID & ACOUSTICAL TILES. FOR INSTALLATION NEW NEW FULL HEIGHT WALL (5/8" FIRE-RATED MOISTURE RESISTANT G.B., EA. SIDE, OVER 3 5/8" STUDS. CENTER OF NEW WALL SHALL BE CENTERED ON EXISTING WINDOW MULLION. MODIFY CEILING GRID & TILES AS NECESSARY.
3. REMOVE GLASS FROM EXISTING WINDOW UNIT. TAKE CARE IN CUTTING OFF SILL & HEAD PORTION OF EXISTING H.M. WINDOW UNIT. SAW-CUT & REMOVE EXISTING CMU BELOW EXISTING WINDOW UNIT FOR INSTALLATION OF NEW DOOR FRAME & DOOR. ANCHOR NEW DOOR FRAME TO EXIST. CMU & GROUT CELLS FULL. NEW DOOR FRAME SHALL ALSO BE CONTINUOUSLY WELDED TO EXISTING WINDOW FRAME (JAMBS & HEAD). INSTALL OWNER-SUPPLIED CARPET TILE AT OPENING AREA.
4. TAKE CARE IN REMOVING EXISTING ACOUSTICAL CEILING TILE & RETURN TO OWNER. REMOVE EXISTING DESIGNATED CEILING GRID. TAKE CARE IN REMOVING EXISTING LIGHT FIXTURES FOR REINSTALLATION. REF. ELECTRICAL. INSTALL NEW MATCHING CEILING GRID & ACOUSTICAL TILE.
5. REMOVE EXISTING LIGHT COVE, LIGHTS & ASSOCIATED WIRING. INSTALL NEW MATCHING CEILING GRID & ACOUSTICAL TILE.
6. REMOVE EXISTING ELECTRICAL & DATA FOR EXISTING TV/MONITOR. REF. ELECTRICAL PLANS.
7. INSTALL SECURITY FILM ON BOTH SIDES OF EXISTING INTERIOR WINDOWS

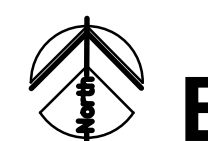

**B** ELEMENTARY SCHOOL  
FIRST FLOOR  
REFLECTED CEILING PLAN  
1/4"=1'-0"

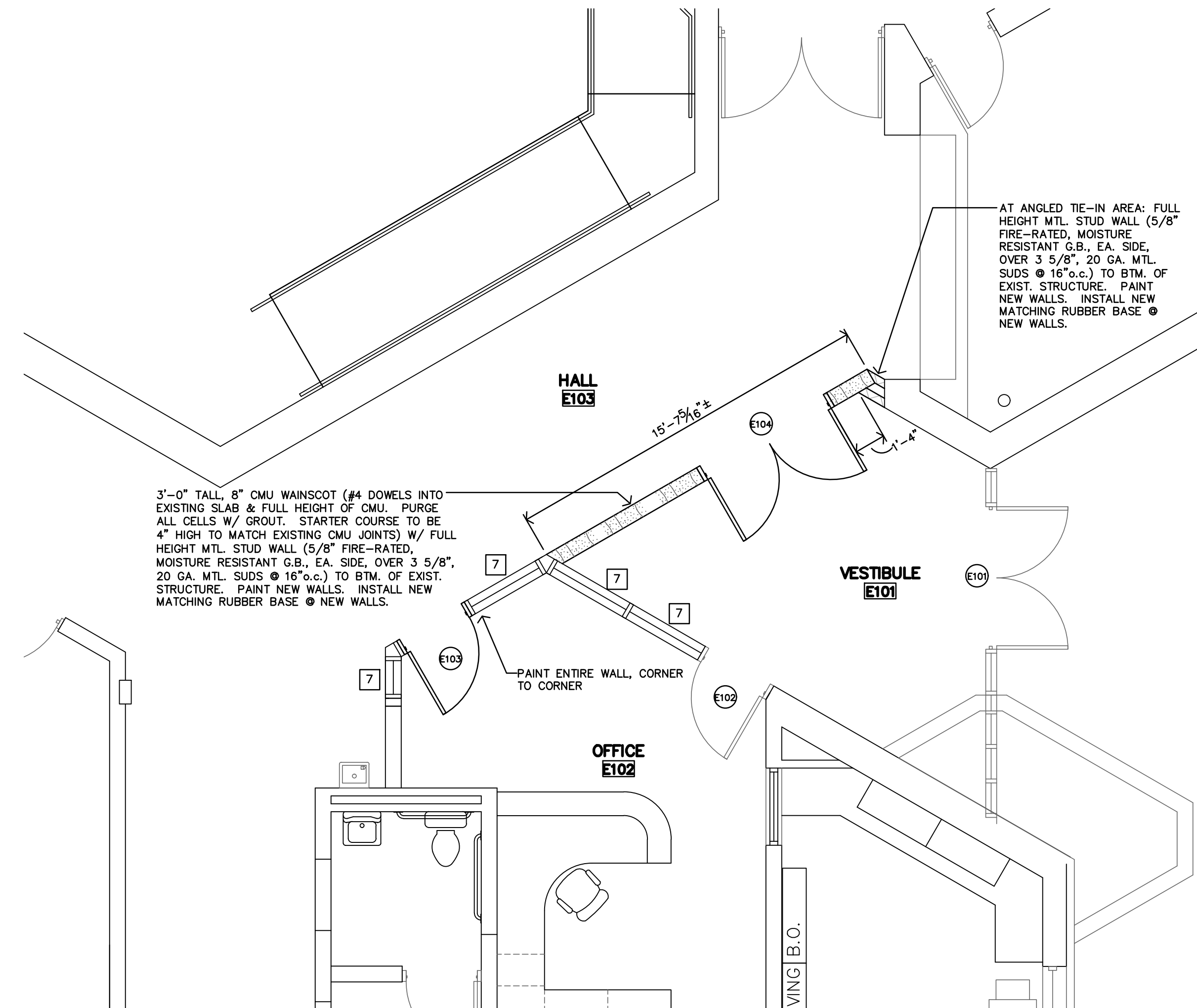

**A** ELEMENTARY SCHOOL  
FIRST FLOOR PLAN  
1/4"=1'-0"

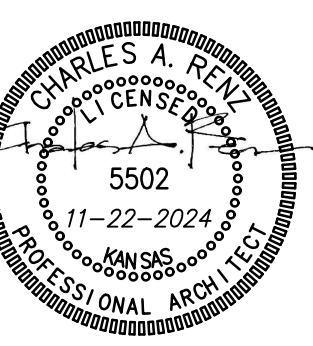

REVISION:	
DATE:	11-22-2024
JOB:	24-3432
SHEET NO.:	

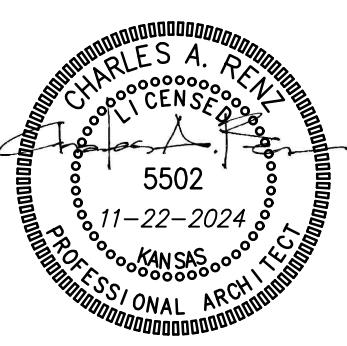

REVISION:

DATE: 11-22-2024  
 JOB: 24-3432  
 SHEET NO.:

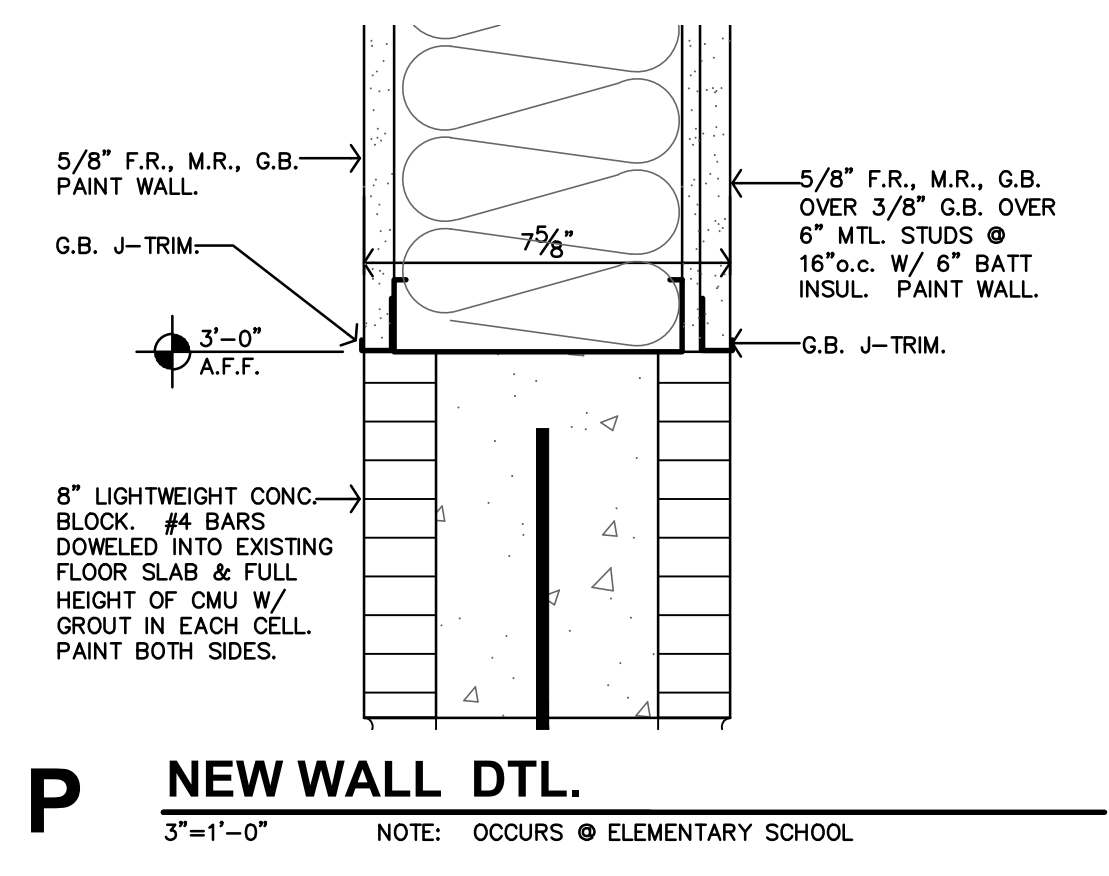

**P NEW WALL DTL.**  
 3\"/>

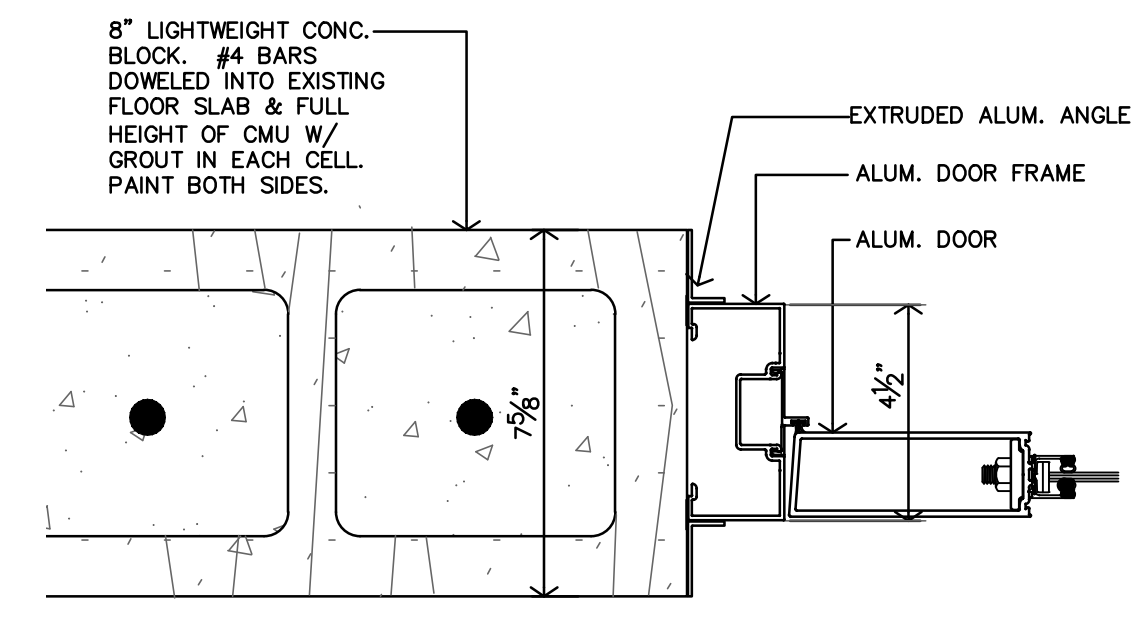

**O INTERIOR DOOR JAMB DTL.**  
 3\"/>

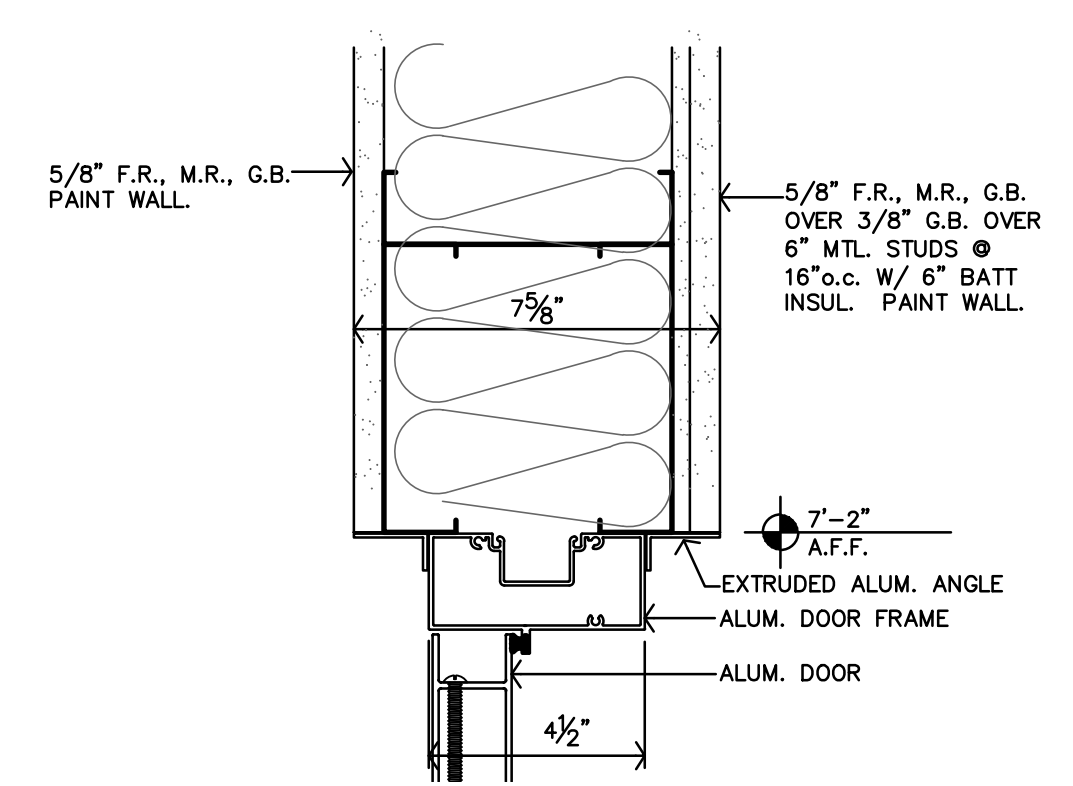

**N INTERIOR DOOR HEAD DTL.**  
 3\"/>

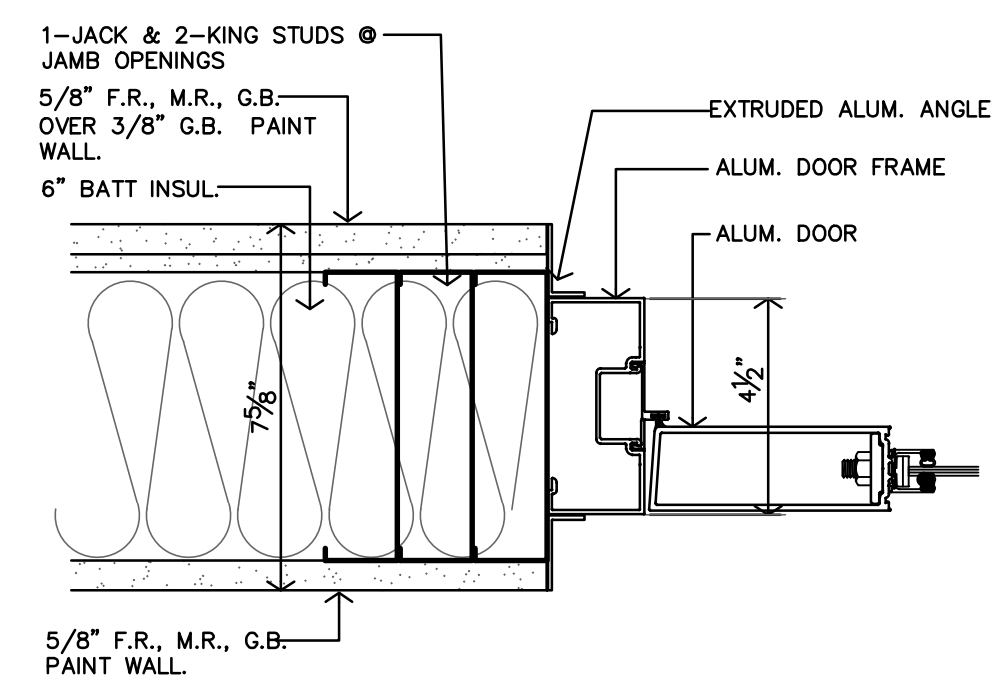

**M INTERIOR DOOR JAMB DTL.**  
 3\"/>

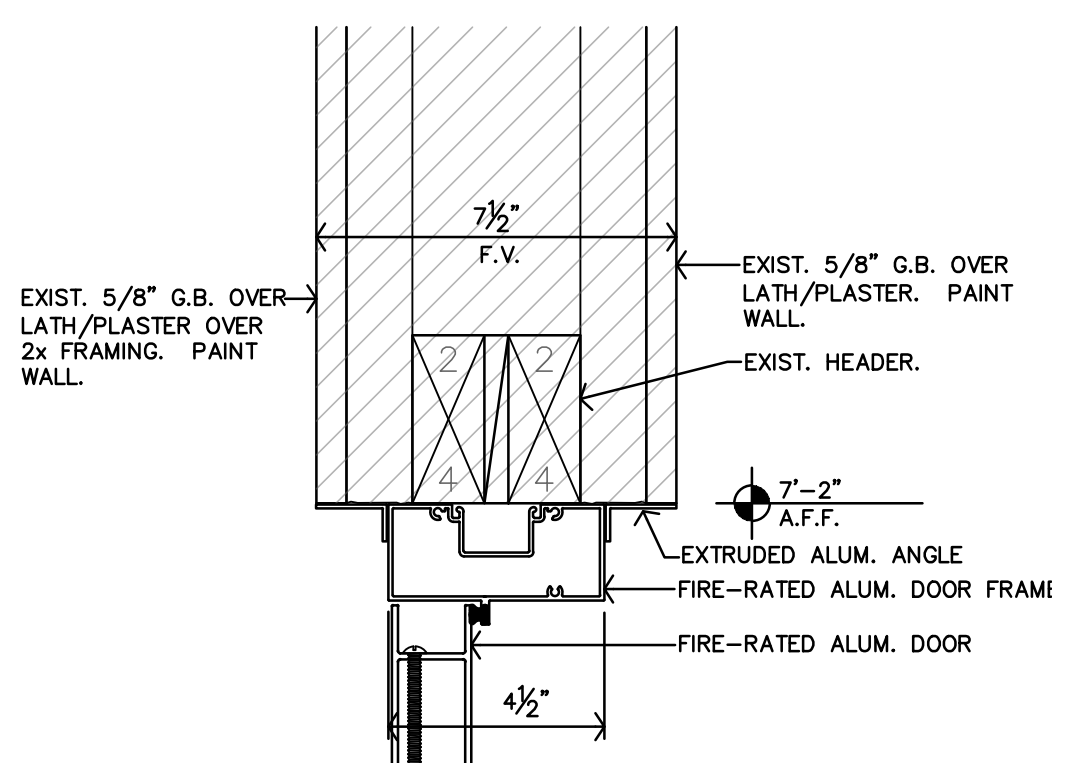

**L INTERIOR DOOR HEAD DTL.**  
 3\"/>

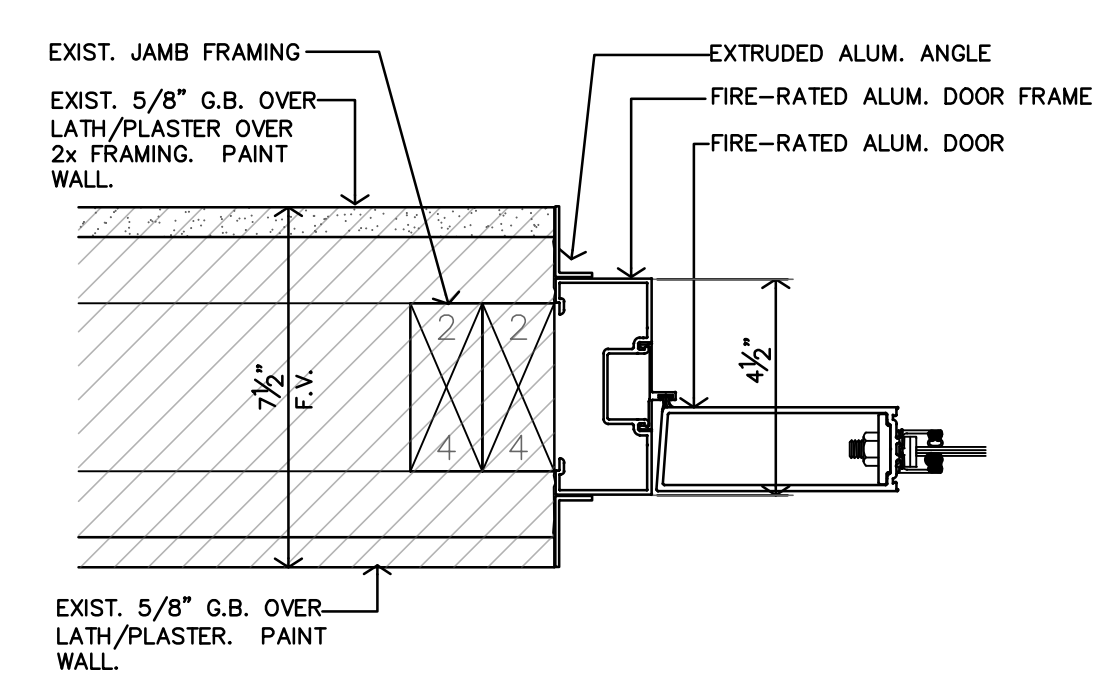

**K INTERIOR DOOR JAMB DTL.**  
 3\"/>

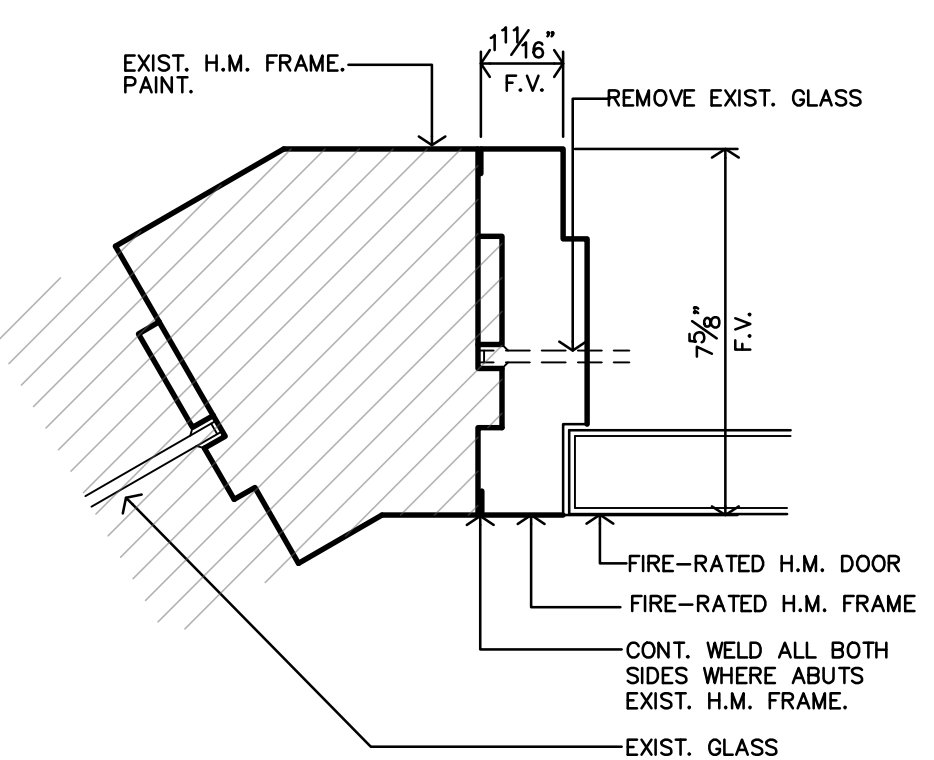

**J INTERIOR DOOR JAMB DTL.**  
 3\"/>

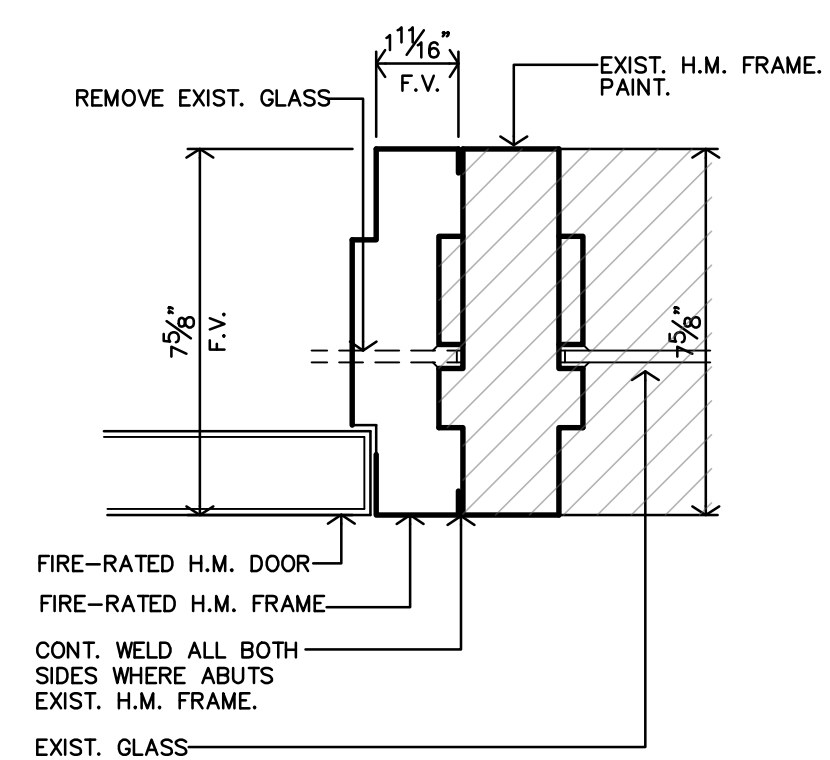

**H INTERIOR DOOR JAMB DTL.**  
 3\"/>

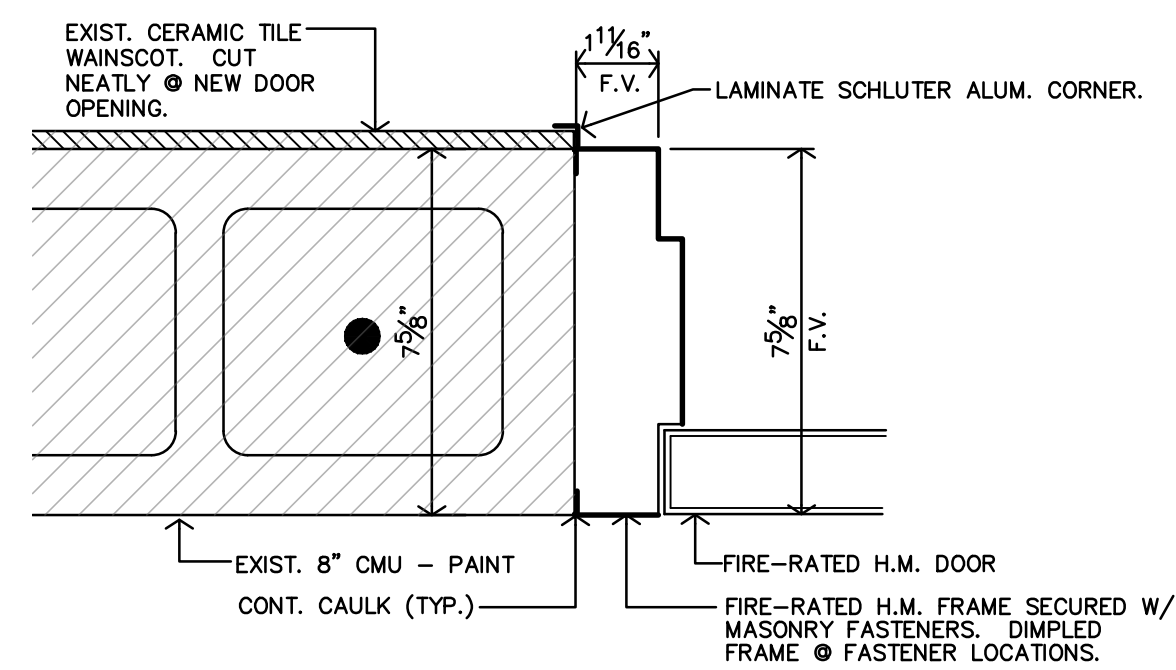

**G INTERIOR DOOR JAMB DTL.**  
 3\"/>

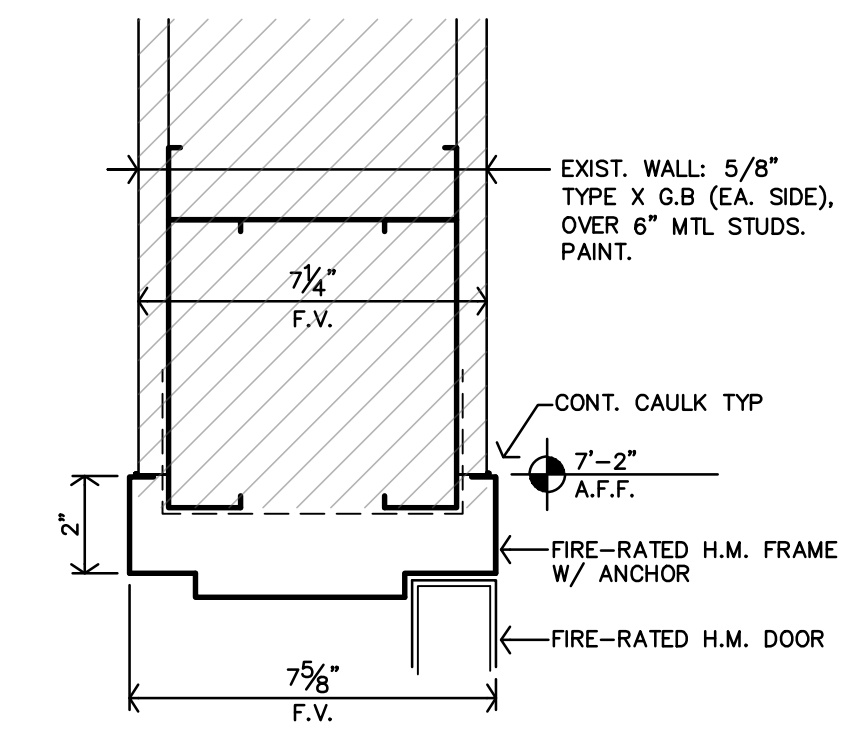

**F INTERIOR DOOR HEAD DTL.**  
 3\"/>

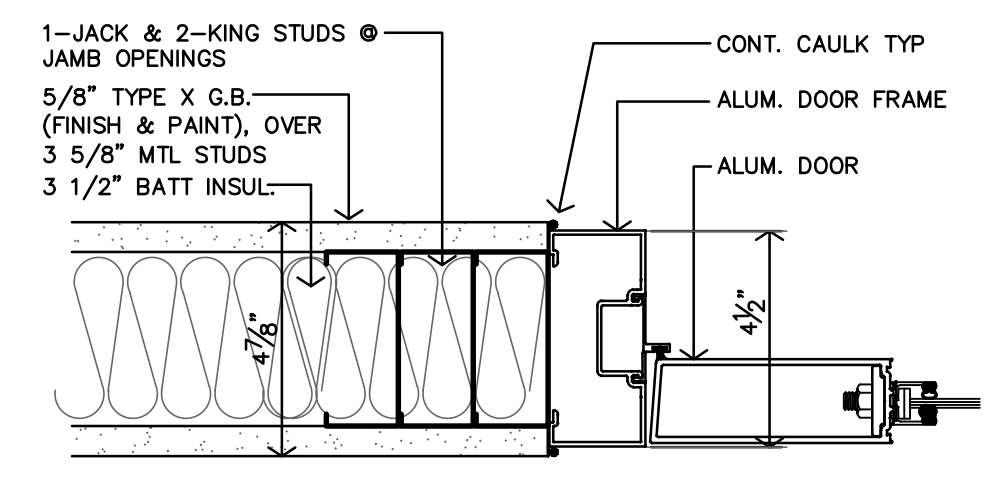

**E INTERIOR DOOR JAMB DTL.**  
 3\"/>

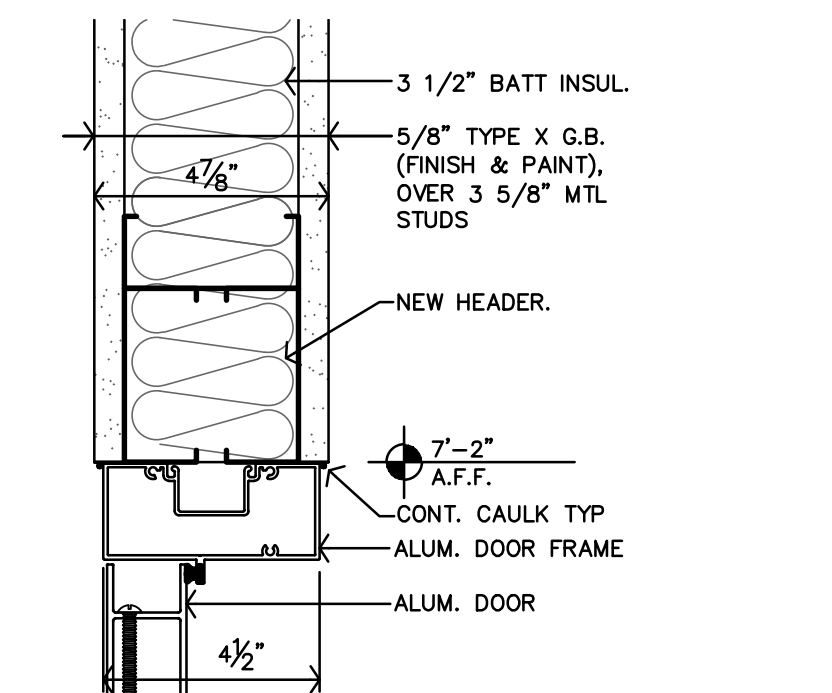

**D INTERIOR DOOR HEAD DTL.**  
 3\"/>

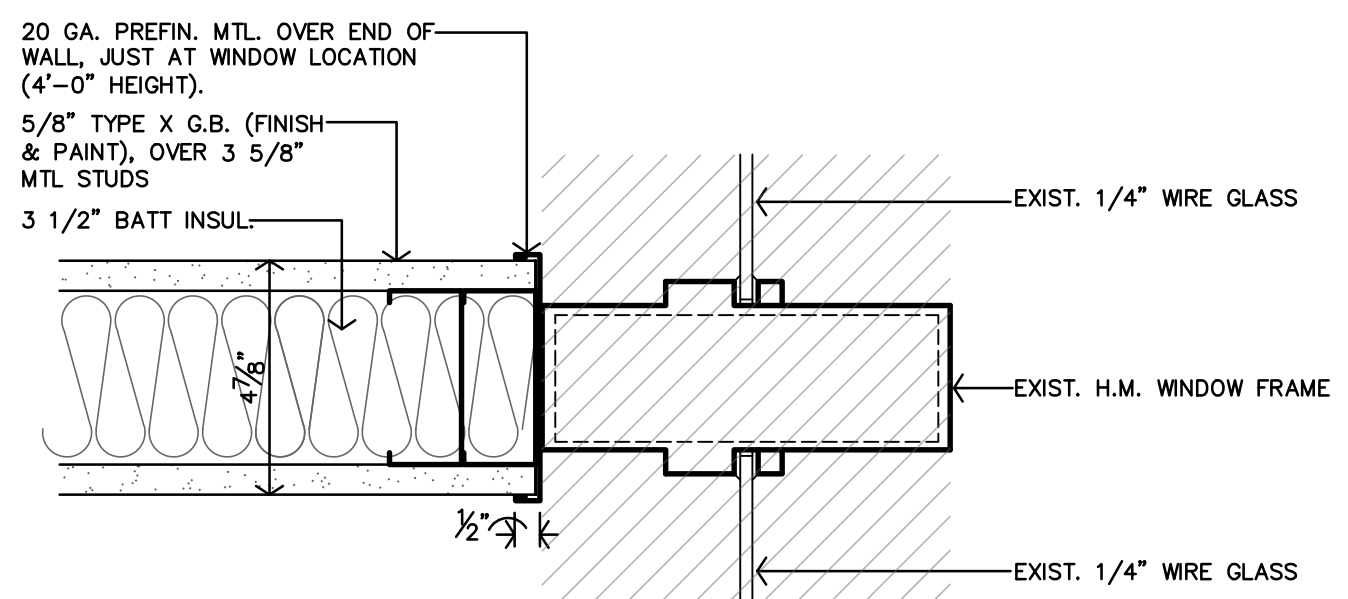

**C NEW WALL @ EXISTING JAMB DTL.**  
 3\"/>

DOOR SCHEDULE														
MARK	DOOR			FRAME				HARDWARE		DETAIL	REMARKS			
	SIZE	MAT'L	TYPE	FINISH	MAT'L	TYPE	FINISH	TYPE	FUNCTION					
JR-SR HIGH SCHOOL														
H101	PR.3'-0"	7'-0"	1 3/4"	E										2
H102	3'-0"	7'-0"	1 3/4"	E	B									3,4,5,6
H103	PR.3'-0"	7'-0"	1 3/4"	E	A									4,6
H104	3'-0"	7'-0"	1 3/4"	E										2
ELEMENTARY SCHOOL														
E101	PR.3'-0"	7'-0"	1 3/4"	E										6
E102	3'-0"	7'-0"	1 3/4"	E										
E103	3'-0"	7'-0"	1 3/4"	E	B									1,3,4,5,6
E104	PR.3'-0"	7'-0"	1 3/4"	E	A									1,4,6

NOTES:  
 1. H.M. DOOR FRAMES TO BE PAINTED W/ INDUSTRIAL ENAMEL UNLESS NOTED OTHERWISE. SPRAY FINISH ONLY. NO BRUSH FINISH.  
 2. E = EXISTING  
 3. EXISTING HEADER TO REMAIN.  
 4. DOORS TO HAVE NEW ELECTRONIC LOCKS ON EXISTING SYSTEM.  
 5. DOOR FRAME & GLASS TO MEET 20-MINUTE FIRE-RATING REQUIREMENTS.  
 6. SECURITY FILM ON BOTH SIDES OF GLASS.

GLAZING SCHEDULE				
MARK	INTERIOR	1/4"	20-MIN. FIRE-RATED	TEMPERED
A1				
B1				

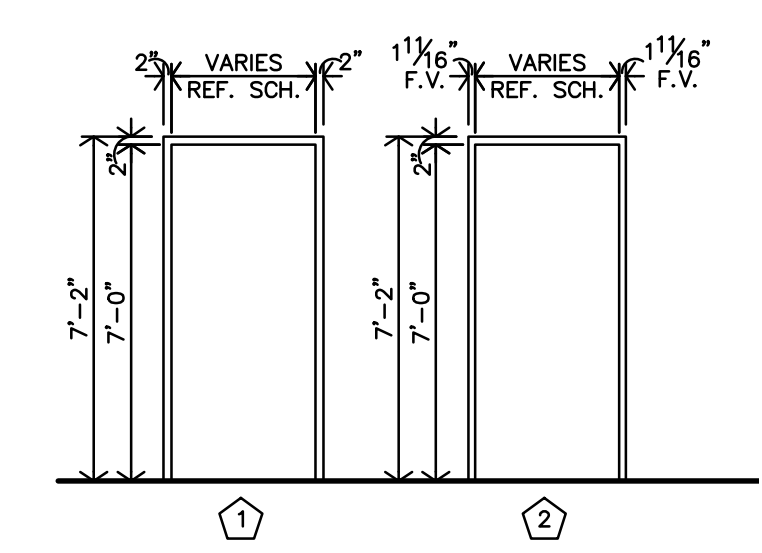

**B DOOR FRAME TYPES**  
 1/4\"/>

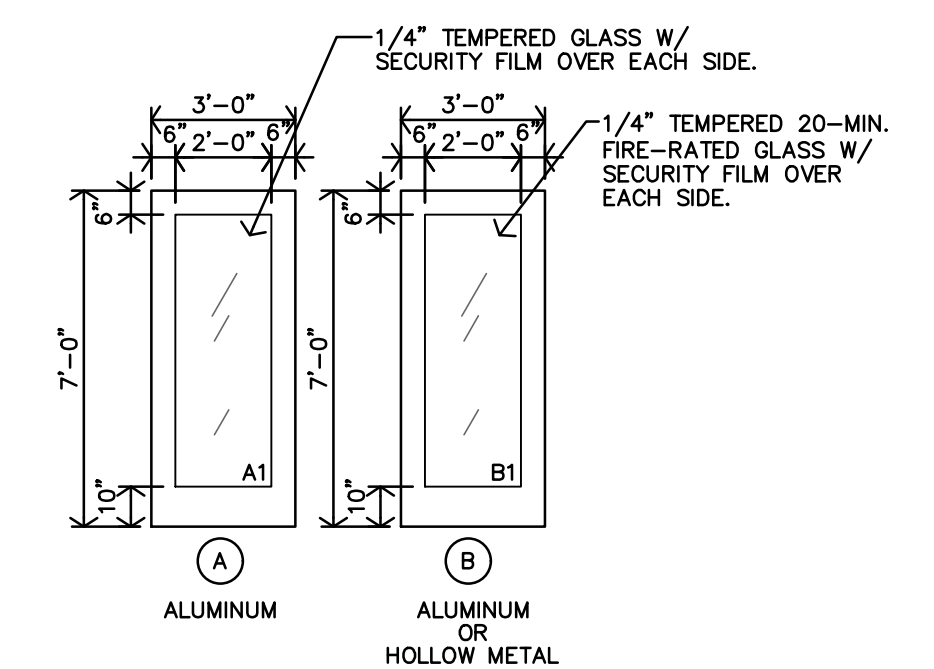

**A DOOR TYPES**  
 1/4\"/>



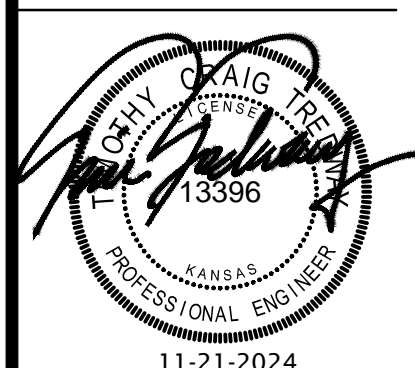

**ELECTRICAL SYMBOLS**

	CIRCUIT DESIGNATION: TOP INDICATES PANEL OF CIRCUIT ORIGIN BOTTOM INDICATES CIRCUIT NUMBER
	HOMERUN - WIRING TO PANEL OF CIRCUIT ORIGIN
	PARTIAL HOMERUN - WIRING TO PANEL OF CIRCUIT ORIGIN
	CONDUIT CONCEALED IN WALL OR ABOVE CEILING
	CONDUIT BELOW GRADE, FLOOR OR EMBEDDED IN CONCRETE
	CONDUIT EXPOSED OVERHEAD
	LINE VOLTAGE CIRCUIT CONDUCTORS SHORT = HOT/TRACER/SWITCH LEG CONDUCTOR LONG = NEUTRAL (GROUNDED) CONDUCTOR CURVED = GROUNDING (BONDING) CONDUCTOR
	CONDUIT STUB OUT WITH NYLON END BUSHING
	CONDUIT TURNED UP
	CONDUIT TURNED DOWN
	EMT CONDUIT SLEEVE WITH NYLON END BUSHINGS
	GROUNDING CONNECTION
	2x4 LAY-IN FIXTURE
	1X4 LAY-IN FIXTURE
	SURFACE MOUNTED LINEAR LUMINAIRE
	STRIP LIGHT
	RECESSED DOWNLIGHT
	WALL MOUNTED LUMINAIRE
	SINGLE FACE EXIT SIGN - WALL AND CEILING MOUNTED WITH DIRECTIONAL ARROWS AS INDICATED ON PLANS
	DOUBLE FACE EXIT SIGN - WALL AND CEILING MOUNTED WITH DIRECTIONAL ARROWS AS INDICATED ON PLANS
	EMERGENCY LIGHTING UNIT
	COMBO EXIT/EMERGENCY LIGHTING UNIT
	COMBO EXIT/EMERGENCY LIGHTING UNIT WITH REMOTE LIGHT HEAD
	SINGLE RECEPTACLE
	DUPLEX RECEPTACLE
	DOUBLE DUPLEX RECEPTACLE
	SPECIAL RECEPTACLE # = NEMA CONFIGURATION
	FLUSH FLOOR DUPLEX RECEPTACLE
	FLUSH FLOOR MULTI-SERVICE OUTLET
	SINGLE POLE WALL SWITCH
	TWO POLE WALL SWITCH
	THREE WAY WALL SWITCH
	FOUR WAY WALL SWITCH
	KEYED WALL SWITCH
	MOTOR HP RATED SWITCH WITHOUT OVERLOAD PROTECTION
	0-10V LED DIMMER WALL SWITCH
	LINE VOLTAGE OCCUPANCY SENSING WALL SWITCH (MANUAL ON/AUTO OFF)
	LOW VOLTAGE CEILING OCCUPANCY SENSOR
	POWER PACK FOR LOW VOLTAGE OCCUPANCY SENSORS
	PUSH BUTTON OPERATOR
	JUNCTION BOX
	MOTOR
	MOTORIZED DAMPER
	DISCONNECT SWITCH
	ENCLOSED CIRCUIT BREAKER
	BRANCH CIRCUIT PANELBOARD, SEE SCHEDULES
	WALL MOUNTED DISTRIBUTION PANELBOARD

**FIRE ALARM SYMBOLS**

	DUCT MOUNTED SMOKE DETECTOR
	FIRE ALARM CONTROL PANEL
	HEAT DETECTOR
	HORN
	HORN/STROBE
	PULL STATION (MANUAL)
	SMOKE DETECTOR
	STROBE

**SYMBOL MODIFYING DESIGNATORS**

CLG	CEILING MOUNTED • FLUSH MOUNTED IN SUSPENDED CEILINGS • SURFACE MOUNTED TO STRUCTURE ABOVE IN OPEN CEILINGS
CT	MOUNT BOTTOM OF DEVICE AT 6" ABOVE COUNTERTOP
e	EXISTING DEVICE OR EQUIPMENT
ETR	EXISTING TO REMAIN
T	TAMPER RESISTANT RECEPTACLE
GFI	GROUND FAULT CIRCUIT INTERRUPTING DEVICE
NL	NIGHTLIGHT WIRED TO UNSWITCHED HOT CONDUCTOR
S	SURFACE MOUNTED
WP	PROVIDE WEATHERPROOF ENCLOSURE FOR DEVICE
XX"	MOUNTING HEIGHT OF DEVICE ABOVE FINISHED FLOOR

**DIVISION 16 - ELECTRICAL**

**SECTION 16010 - GENERAL ELECTRICAL REQUIREMENTS**

16010.01	The drawings and general provisions of the Contract, including General Conditions, Supplementary General Conditions, and General Requirements apply to the work specified in Division 16 - ELECTRICAL.
16010.02	The Electrical Contract includes all labor, material and equipment required for the complete electrical systems as shown and specified.
16010.03	This contractor is responsible for reviewing ALL drawings to determine extent of coordination required with other trades. Additional offsets, bends, and materials will not be accepted as a result of un-coordinated work.
16010.04	This contractor is required to perform work in a professional and quality workman like manner. This includes, but is not limited to: a. Make vertical elements plumb and horizontal elements level unless noted otherwise. b. Install equipment and fittings plumb and level, neatly aligned with adjacent vertical and horizontal lines, unless noted otherwise. c. Protect work from damage and water during construction. Replace all equipment/material damaged or exposed to water during construction. d. Clean equipment, interior and exterior, at completion of construction and remove all temporary labels, stains and foreign substances.
16010.05	Each major component of equipment shall have the manufacturer's name, address, model number, and U.L. label securely affixed in a conspicuous place.
16010.06	All equipment of one type (such as panelboards, switches, wiring devices, etc.) shall be the product of one manufacturer, unless specified otherwise.
16010.07	Where the quality of required material is not specified, the Contractor shall furnish a first class standard item as approved by the Architect/Engineer.
16010.08	The quantity or quality level shown or specified shall be the minimum provided or performed. The actual installation may comply exactly with the minimum quantity or quality specified, or it may exceed the minimum within reasonable limits. To comply with these requirements, indicated numeric values are minimum or maximum, as appropriate for the context of requirements. Refer uncertainties to Architect for a decision before proceeding. Where the quality of required material is not specified, the Contractor shall furnish a first class standard item as approved by the Architect/Engineer.
16010.09	Manufacturer's names are intended to establish type and quality of items to be provided via the contract. The materials, products, and equipment described in the specifications or on the drawings establish a standard of required function, dimension, appearance, and quality to be met by any proposed substitution. Listing of these manufacturers shall in no way be construed as a device intended to limit the bidders to those specifically listed.
16010.10	Install all equipment in strict accordance with the manufacturer's recommendations and the shop drawings approved by the Engineer.
16010.11	All work under this contract shall conform to the requirements of the 2017 National Electrical Code (NFPA 70) and all applicable local, state, and federal code requirements. If compliance with two or more standards is specified and the standards establish different or conflicting requirements for minimum quantities or quality levels, comply with the most stringent requirement. Refer uncertainties and requirements that are different, but apparently equal, to Architect for a decision before proceeding.
16010.12	Periodically during construction and prior to Owner acceptance of the building, Contractor shall remove from the premises and dispose of all packing material and debris associated with the Work specified under this Division.
16010.13	Before submitting bid, the Contractor shall visit the actual location of the job and shall fully understand the scope of the work to be done and the condition under which it is to be performed.
16010.14	Notify the Engineer of errors, discrepancies, or omissions in the drawings and specifications before construction or fabrication of affected work, or failing such notice, be responsible for correction of such work without cost to the Owner, Architect, or Engineer.
16010.15	Where fire rated construction is penetrated by this Work, fire seal at penetrations with UL listed fire sealing system. Refer to Architectural drawings and specifications.
16010.18	Provide Shop Drawings for the following electrical equipment. Refer to Division 1 specifications for submittal process. Electrical equipment listed below shall not be ordered or installed until shop drawings have been submitted and reviewed. Shop Drawings shall include product data indicating performance, dimensions, finish/color and configuration. Include all accessories and installed components. Light Fixtures (provided by Contractor); Wiring Devices;

**SECTION 16060 - GROUNDING**

16060.01	The entire electrical system, including all special power systems, shall be grounded in accordance with the National Electrical Code.
16060.02	Equipment grounding conductors shall be installed in all conduits. The conduit system shall not be used as the sole means of grounding.

**1 ELECTRICAL SPECIFICATIONS**  
NO SCALE

**SECTION 16110 - RACEWAYS**

16110.01	Provide the conduits and raceways as specified and indicated on the plans.
16110.02	All exterior above grade raceways shall be Galvanized Rigid Metal Conduit (RMC) or Intermediate Metal Conduit (IMC) with threaded couplings and fittings.
16110.04	All interior dry location raceways shall be thinwall Electrical Metallic Tubing (EMT) with compression or setscrew couplings and fittings.
16110.05	Flexible Metal Conduit (FMC) may be used for final connections to light fixtures and vibrating equipment in lengths not to exceed 6'-0" and where fished through existing wall construction. Utilize Liquid Tight Flexible Metal Conduit (LFMC) where exposed to moisture.
16110.06	Single conduits shall be used for all circuits, but more than one circuit may be carried in each conduit, provided the number of conductors and size of conductors are proportioned in accordance with the rules of the NEC, and conduits are of ample size to allow for removal and replacement of conductors when necessary. Do not exceed 40% fill.
16110.07	Where conduit is carried in walls, it shall be thoroughly bedded and not visible. In placing conduits, they shall be so located as to not weaken or injure the construction of the building in any way, and the installation of these shall be approved by the Architect.
16110.08	Joints must be made so the ends of the pipes come together in the center of the coupling.
16110.09	All conduit shall be run parallel or perpendicular to the building surfaces.
16110.10	All empty conduit systems shall be provided with suitable pull strings.
16110.11	Conduit sleeves will be required in all penetrations through exterior walls and floors. Sleeves shall be Schedule 5 steel pipe, EMT conduit, or field fabricated from minimum 16 gauge steel with 2" overlap at the seam. The Electrical Contractor shall be responsible for locating and setting his own sleeves, and be well aware of the job progress to avoid unnecessary delay for setting of same. Space between sleeves and conduit in outside walls shall be filled or tightly caulked with oakum, butyl rubber, link seals or other approved equally effective material to resist the penetration of water. Sleeves shall be of sufficient diameter to provide approximately 1/2" clearance around pipe. Sleeves shall be set no closer than two pipe diameters center to center and shall be set 3/4" past all wall surfaces, and be securely anchored to the wall.

**SECTION 16120 - BUILDING WIRE AND CABLES**

16120.01	Provide the wire and cable as specified and as shown on the drawings. Wire and cable shall be manufactured by AFC Cable Systems, Alan Wire, Cerrowire, Encore Wire, General Cable or Southwire.
16120.02	Building wire shall be annealed (soft) copper. The use of Aluminum conductors is NOT permitted. Conductors #10 AWG and smaller shall be solid, #8 AWG and larger shall be stranded. Unless noted otherwise, minimum wire size shall be as follows: a. Power supply circuits: #12 AWG b. NEC Class 1 remote-control, signaling and power-limited circuits: #16 AWG
16120.03	Building wire for power supply circuits shall have NEC type THHN/THWN-2 insulation rated for 90°C, 600V, and suitable for use in wet or dry locations.
16120.05	Install all building wire for power supply circuits in conduit, unless noted otherwise.
16120.06	Wire shall be lubricated with "Polywater," or equally effective cable lubricating material as recommended by wire manufacturer.
16120.07	Machine or power pulling of cables into raceways shall be accomplished such that pulling stresses shall not exceed those recommended by the manufacturer.
16120.08	MC Cable shall be manufactured to UL 1569 standard and have steel or aluminum interlocked armor, THHN/THWN single insulated solid copper conductors and a full size green insulated solid copper equipment grounding/bonding conductor. If applicable, cable shall include control wiring for 0-10 V-dc dimming signal consisting of 16 AWG solid twisted pair copper conductors with TFN insulation and an outer jacket. Control circuit component shall be suitable for use in NEC Class 1 circuits.
16120.09	MC cable may be used ONLY for final connections (whips) to light fixtures in lengths not to exceed 6'-0", and where fished through existing walls.

**SECTION 16130 - ELECTRICAL BOXES AND FITTINGS**

16130.01	Provide all electrical pull, junction and outlet boxes as specified and shown on the drawings, as well as those required for a complete and code acceptable installation.
16130.02	Junction and pull boxes shall be galvanized metal of the knockout type, and shall be provided throughout in accessible locations.
16130.03	All outlet boxes for light fixtures, receptacles, and wall switches in dry locations shall be of the Steel City, or equal, galvanized knockout type. Lighting fixture outlet boxes in ceiling shall be not less than 4" square of the knockout type. Gangable type boxes shall be used in all gypsum surfaces. Plug unused openings in all boxes.
16130.04	Install boxes for switch and receptacle outlets at the locations shown on the drawings, allowing for relocation of up to 4 feet in any direction if so directed prior to rough-in, without additional cost to the Owner. Boxes shall be flush mounted on all walls for concealed work in occupied/finished areas.
16130.05	Electrical boxes located in 1-hour fire rated walls shall be installed as follows: a. Boxes shall be U.L. listed for use in fire rated assemblies. b. Annular space around listed boxes shall not exceed 1/8". c. Boxes on opposite sides of the fire rated wall shall comply with one of the following: 1. Be separated by the horizontal distance specified in the listing of the electrical box. 2. Be separated by fire blocking material in accordance with IBC section 717.2.1. 3. Protect both boxes with listed fire rated putty pads.
16130.06	Electrical boxes located in fire rated ceiling/floor assemblies shall: a. Be steel construction and not exceed 16 square inches in area. b. Annular space around ceiling boxes shall not exceed 1/8". c. The aggregate area of ceiling boxes does not exceed 100 square inches for every 100 square feet of ceiling area.
16130.07	All boxes and fittings in wash bays shall be liquid tight PVC with gasketed covers.

**SECTION 16140 - WIRING DEVICES**

16143.01	Provide the wiring devices and cover plates as specified.
16143.02	Wiring Devices shall be as manufactured by Pass & Seymour, Leviton, Hubbell, Eaton, or approved equal. Devices shall be commercial specification grade, rated at 20 amps, 120 volts, unless specified otherwise. Coordinate device color with Architect. Devices shall be as follows: a. Wall Receptacles: 1. Duplex Receptacle P&S #PS5362.
16143.03	Terminations at wiring devices shall be made using screw terminals only. Use of "stab-in" connections is not acceptable.
16143.06	All flush-mounted wiring devices in finished areas shall be provided with stainless steel cover plates.
16143.07	Cover plates for wiring devices in surface-mounted boxes and unfinished areas shall be galvanized utility box covers, raised 1/4".
16143.08	Where more than one device is in a single location, utilize a one-piece multigang cover plate.

**SECTION 16510 - LIGHT FIXTURES**

16510.01	Provide the light fixtures as specified and scheduled on plans. Material, equipment or services necessary to complete the installation of these fixtures, but not specifically mentioned shall be furnished as though specified.
16510.02	UL or CSA US Listing: Light fixtures shall be manufactured in strict accordance with the appropriate and current requirements of the "Standards for Safety" to UL 8750 or others as they may be applicable. A listing shall be provided for each fixture type, and the appropriate label or labels shall be affixed to each fixture in a position concealing it from normal view.
16510.03	Approved Manufacturers: Provide products of firms regularly engaged in the manufacture of light fixtures of types and ratings required, whose products have been in satisfactory use in similar service for not less than 5 years. The manufacturer of the lighting fixtures shall comply with the provisions of the appropriate code and standards.
16510.04	LED FIXTURES - Comply with UL 1598. Test according to IESNA LM 80-08, where life expectancy is specified. Provide luminaires with the following characteristics unless otherwise noted: a. Life: 50,000 hours minimum interior/100,000 hours minimum exterior b. Efficacy: 90 lumens/watt c. CRI: 80 minimum interior/70 minimum exterior d. MacAdam ellipse: 4-step minimum per ANSI recommendations
16510.05	LED's shall be manufactured by, Nichia, Samsung, LG, Osram, Philips or Cree. a. Individual LEDs shall be connected such that a catastrophic loss or the failure of one LED will not result in the loss of the entire luminaire b. LED Boards shall be suitable for field maintenance or service from below the ceiling with plug-in connectors.
16510.06	LED drivers shall be manufactured by eldoLED, Osram, Philips or Cree. Drivers shall have <10% total harmonic distortion, minimum 95% power factor, and universal 120/277 volt operation.
16510.07	Light fixture manufacturers shall provide a warranty against loss of performance and defects in materials and workmanship for the fixtures for a period of 5 years after acceptance of the products. Warranty shall cover all components comprising the fixture.

**END DIVISION 16 - ELECTRICAL**

Ⓢ **ELECTRICAL PLAN NOTES BY SYMBOL**

1. PROVIDE ADDITIONAL RECEPTACLE AT ACCESS CONTROL SYSTEM PANEL LOCATION. CONNECT TO EXISTING CIRCUIT SERVING EXISTING RECEPTACLE SERVING ACCESS CONTROL SYSTEM USING (2)#12, #12G, IN 1/2" C. MODIFY EXISTING CIRCUITRY AS REQUIRED. FIELD VERIFY EXACT AND REQUIREMENTS. FIELD VERIFY EXACT LOCATION OF NEW CONTROL SYSTEM PANEL WITH ACCESS CONTROL SYSTEM PROVIDER PRIOR TO ROUGH-IN.
2. REMOVE AND REPLACE/ RELOCATE EXISTING LIGHT FIXTURE IN EXISTING CEILING IF REQUIRED FOR NEW CONSTRUCTION. FIELD COORDINATE EXACT REQUIREMENTS WITH G.C.
3. PROVIDE NEW RECEPTACLE AND CIRCUIT WITH (2)#12, #12G, IN 1/2C TO NEAREST EXISTING RECEPTACLE CIRCUIT. MODIFY EXISTING CIRCUITRY AS REQUIRED. FIELD VERIFY EXACT REQUIREMENTS AND LOCATION.

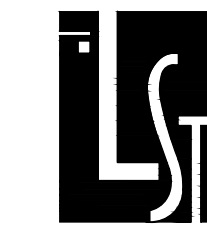

IST Consulting Engineers, PA  
 MANHATTAN, KS 66503  
 4809 Vue Du Lac Plaza, Suite 201  
 785.587.8042  
 www.ISTengineers.com  
 mail@ISTengineers.com

WICHITA, KS 67202  
 125 S. Washington, Suite 150  
 316.285.0696  
 Project 24087  
 November 2023

**JGR** Jones Gilliam Renz  
 730 N. Ninth  
 Salina, KS 67401  
 785.827.0386  
 1881 Main Street, Suite 301  
 Kansas City, MO 64108  
 jgr@jgrarchitects.com

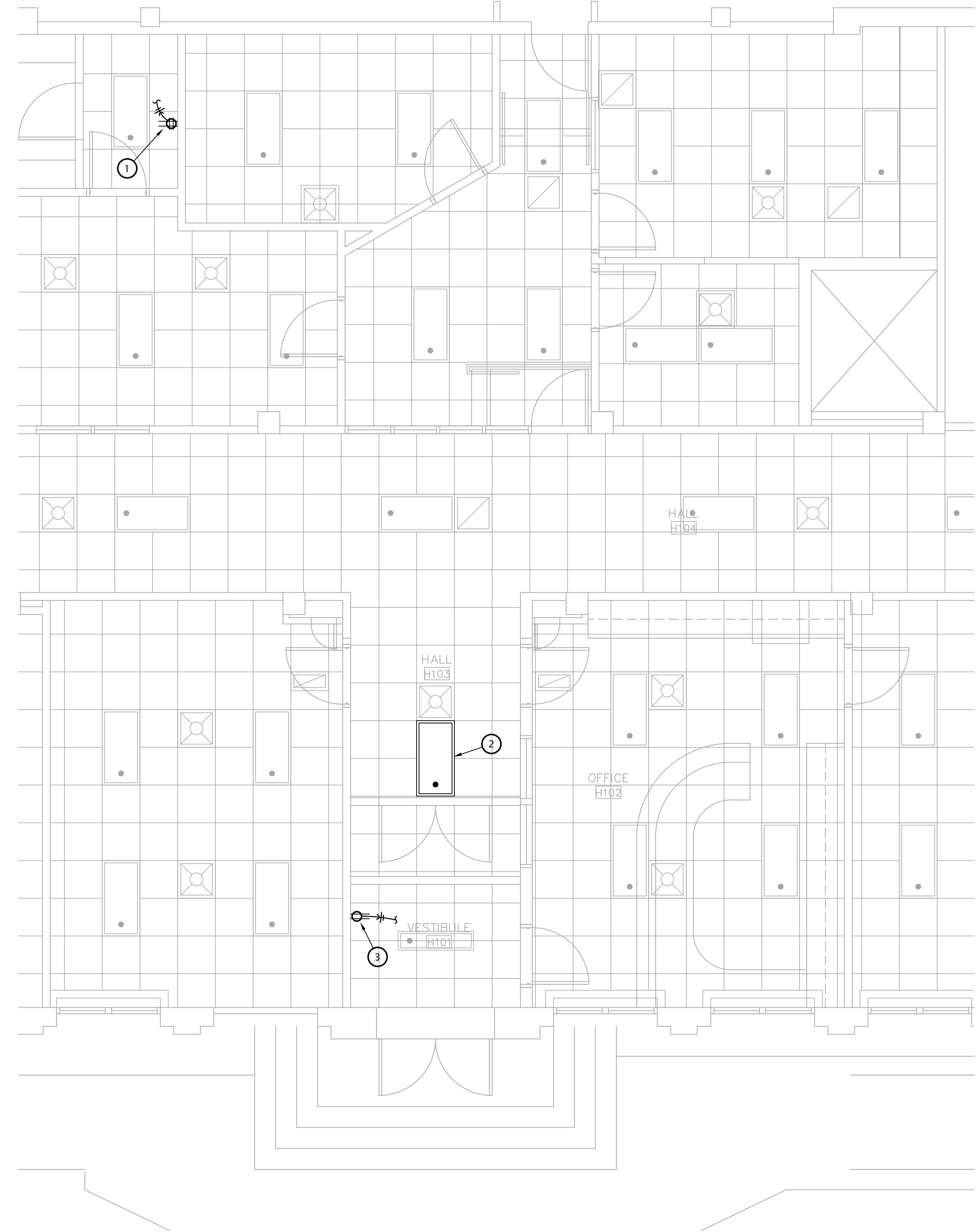

① **JR-SR HIGH SCHOOL ELECTRICAL PLAN**  
 1/4" = 1'-0"



**USD 307 ELL SALINE**  
**SECURE ENTRIES**  
 SALINA, KANSAS

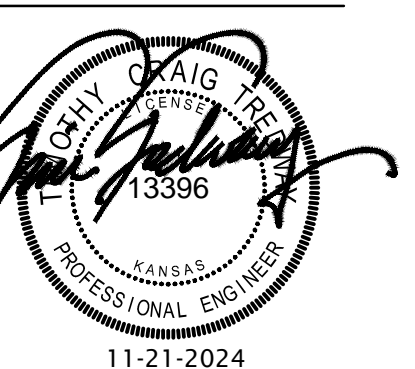

REVISION:	
DATE:	11-21-2024
JOB:	24-3432
SHEET NO.:	

**E1.1**

COPYRIGHTED ©

**GENERAL DEMOLITION NOTES**

1. REMOVE ALL MECHANICAL AND ELECTRICAL INSTALLATION FROM PROJECT AREA, UNLESS REQUIRED FOR NEW WORK OR EXISTING INSTALLATION NOT AFFECTED BY REMODEL. COORDINATE WITH OWNER AND G.C.
2. SERVICES TO ITEMS NOT REMOVED AS PART OF THIS WORK SHALL BE RESTORED UPON COMPLETION OF THIS WORK TO FULLY OPERATIONAL CONDITION.
3. NOT ALL ITEMS REQUIRED TO BE DEMOLISHED MAY BE INDICATED ON DRAWINGS. ALL DEMOLITION OF AFFECTED SPACE SHALL BE PERFORMED AS IF INDICATED.
4. DELIVER DEMOLISHED EQUIPMENT, WIRING, ETC. TO OWNER OR DISPOSE OF, AS DIRECTED BY OWNER.
5. FIELD VERIFY EXACT LOCATION OF ALL EXISTING MECHANICAL AND ELECTRICAL EQUIPMENT INDICATED ON DRAWINGS.
6. ALL ITEMS TO BE RE-USED OR RELOCATED SHALL BE CLEANED, REPAIRED, AND RESTORED TO LIKE NEW CONDITION PRIOR TO RE-USE.

**GENERAL ELECTRICAL DEMOLITION NOTES**

1. REMOVE ALL NM, BX, MC, AC AND OTHER CABLE SYSTEMS AND WIRING FOR ALL ABANDONED CIRCUITS.
2. REMOVE ALL ABANDONED CONDUITS ABOVE LAY-IN CEILINGS, EXPOSED CONDUITS, FLEXIBLE CONDUITS, SURFACE RACEWAY, SURFACE MOUNTED OUTLET/JUNCTION BOXES AND EQUIPMENT UNLESS NOTED OTHERWISE.
3. WHERE ABANDONED FEEDERS AND BRANCH CIRCUITS ARE CONCEALED WITHIN WALLS, FLOORS AND HARD CEILINGS THAT ARE TO REMAIN, REMOVE ALL WIRING AND CAP CONDUITS AT BOTH ENDS.
4. WHERE ABANDONED OUTLET AND JUNCTION BOXES ARE RECESSED FLUSH IN WALLS, FLOORS AND HARD CEILINGS THAT ARE TO REMAIN, REMOVE ALL WIRING AND WIRING DEVICES AND PROVIDE BLANK STAINLESS STEEL COVERPLATES FOR BOXES 6"x6" AND SMALLER. REMOVE BOXES LARGER THAN 6"x6" AND PATCH SURFACE TO MATCH EXISTING. COORDINATE WITH ARCHITECT FOR FINAL DIRECTION.
5. ALL EQUIPMENT, FIXTURES, RACEWAY, WIRING AND DEVICES WHICH ARE REMOVED SHALL BE REMOVED FROM THE JOB SITE BY THIS CONTRACTOR, UNLESS DIRECTED OTHERWISE BY THE ARCHITECT OR OWNER'S REPRESENTATIVE. CONFORM TO ALL LAWS AND ORDINANCES IN EFFECT CONCERNING THE PROPER DISPOSAL OF LUMINAIRES AND LAMPS.
6. COORDINATE THE REMOVAL OF MECHANICAL EQUIPMENT WITH THE MECHANICAL CONTRACTOR. DISCONNECT AND REMOVE ELECTRICAL POWER AND CONTROL CIRCUITS FOR EQUIPMENT BEING REMOVED. REMOVE ALL ELECTRICAL EQUIPMENT ASSOCIATED WITH DEMOLISHED MECHANICAL EQUIPMENT (DISCONNECT SWITCHES, MOTOR STARTERS, RELAYS, ETC).

**ELECTRICAL DEMOLITION NOTES BY SYMBOL**

1. EXISTING LIGHT FIXTURE TO REMAIN. MODIFY CIRCUITRY AS REQUIRED TO ACCOMMODATE NEW WORK.
2. REMOVE EXISTING LIGHT FIXTURE AND RETAIN FOR USE IN NEW WORK, MODIFY CIRCUITRY AS REQUIRED TO ACCOMMODATE NEW WORK.
3. EXISTING LIGHT SWITCH TO REMAIN. MODIFY CIRCUITRY AS REQUIRED TO ACCOMMODATE NEW WORK.
4. EXISTING DUPLEX TO REMAIN.
5. REMOVE AND RELOCATE EXISTING DATA OUTLET. COORDINATE REQUIREMENTS WITH OWNER.
6. REMOVE AND RELOCATE EXISTING DUPLEX RECEPTACLE. MODIFY EXISTING CIRCUITRY AS REQUIRED.
7. REMOVE EXISTING LIGHT FIXTURE AND ALL ASSOCIATED CIRCUITRY.
8. EXISTING FIRE ALARM DEVICES TO REMAIN.

**ELECTRICAL PLAN NOTES BY SYMBOL**

1. CIRCUIT NEW LIGHT FIXTURE TO EXISTING CIRCUITRY SERVING LIGHTING IN HALLWAY AND EXISTING SWITCH USING (2)#12G, #12G, IN 1/2" C. MODIFY EXISTING WIRING AS REQUIRED. FIELD VERIFY EXACT REQUIREMENTS.
2. RE-INSTALL EXISTING FIXTURE RETAINED FROM DEMOLITION. CONNECT TO EXISTING SWITCHED LIGHTING CIRCUIT SERVING THIS AREA USING (2)#12G, #12G, IN 1/2" C. MODIFY EXISTING CIRCUITRY AS REQUIRED. CLEAN, AND RE-LAMP EXISTING FIXTURE PRIOR TO RE-USE.
3. CONNECT EMERGENCY/ EXIT LIGHT TO UNSWITCHED CIRCUIT SERVING LIGHTING IN THIS ROOM USING (2)#12, #12G, IN 1/2" C. MODIFY EXISTING CIRCUITRY AS REQUIRED. FIELD VERIFY EXACT REQUIREMENTS.
4. PROVIDE ADDITIONAL RECEPTACLE AT ACCESS CONTROL SYSTEM PANEL LOCATION. CONNECT TO EXISTING CIRCUIT SERVING EXISTING RECEPTACLE SERVING ACCESS CONTROL SYSTEM USING (2)#12, #12G, IN 1/2" C. MODIFY EXISTING CIRCUITRY AS REQUIRED. FIELD VERIFY EXACT AND REQUIREMENTS. FIELD VERIFY EXACT LOCATION OF NEW CONTROL SYSTEM PANEL WITH ACCESS CONTROL SYSTEM PROVIDER.
5. PROVIDE NEW RECEPTACLE AND CIRCUIT WITH (2)#12, #12G, IN 1/2" TO NEAREST EXISTING RECEPTACLE CIRCUIT. MODIFY EXISTING CIRCUITRY AS REQUIRED. FIELD VERIFY EXACT REQUIREMENTS AND LOCATION.
6. RE-LOCATE EXISTING RECEPTACLE AND DATA OUTLET TO ABOVE CEILING FOR RELOCATED MONITOR. COORDINATE EXACT LOCATION AND REQUIREMENTS WITH OWNER PRIOR TO ROUGH-IN. MODIFY EXISTING CIRCUITRY AS REQUIRED, FIELD VERIFY EXACT REQUIREMENTS.

**LIGHT FIXTURE SCHEDULE**

MARK	MANUF.	MODEL NUMBER	LAMP DATA	DRIVER	MOUNTING	FINISH	DESCRIPTION	NOTES
A	COLUMBIA	CFP24-55/41/3440	50W LED 6,140 LUMEN	0-10V DIMMING	LAY-IN	WHITE	4000K, LED 2'x4' SELECTABLE LUMENS EDGELIT FLAT PANEL	
XE	DUAL-LITE	EVCURWI	LED	N/A	UNIVERSAL	RED LETTERS WHITE HOUSING	COMBO EXIT/EMERGENCY LIGHTING UNIT	1,2
XER	DUAL-LITES	EVCURWD41 + EVOD8	LED + (2)1W REMOTE HEAD	N/A	UNIVERSAL	RED LETTERS WHITE HOUSING BLACK REMOTE	COMBO EXIT/EMERGENCY LIGHTING UNIT WITH DOUBLE REMOTE HEADS	1,2,3

- GENERAL:**
- All LED's shall be 4000 K correlated color temperature, minimum 80 CRI.
  - All light fixtures shall be provided with universal drivers capable of operating at 120V or 277V UNO.
- NOTES:**
1. Fixture shall be capable of wall or ceiling mount applications and shall have break-out directional chevrons.
  2. Provide with emergency battery integral charger and self-diagnostic/self-testing electronics.
  3. Install remote head on exterior wall above door and connect to unit per manufacturer's instructions.

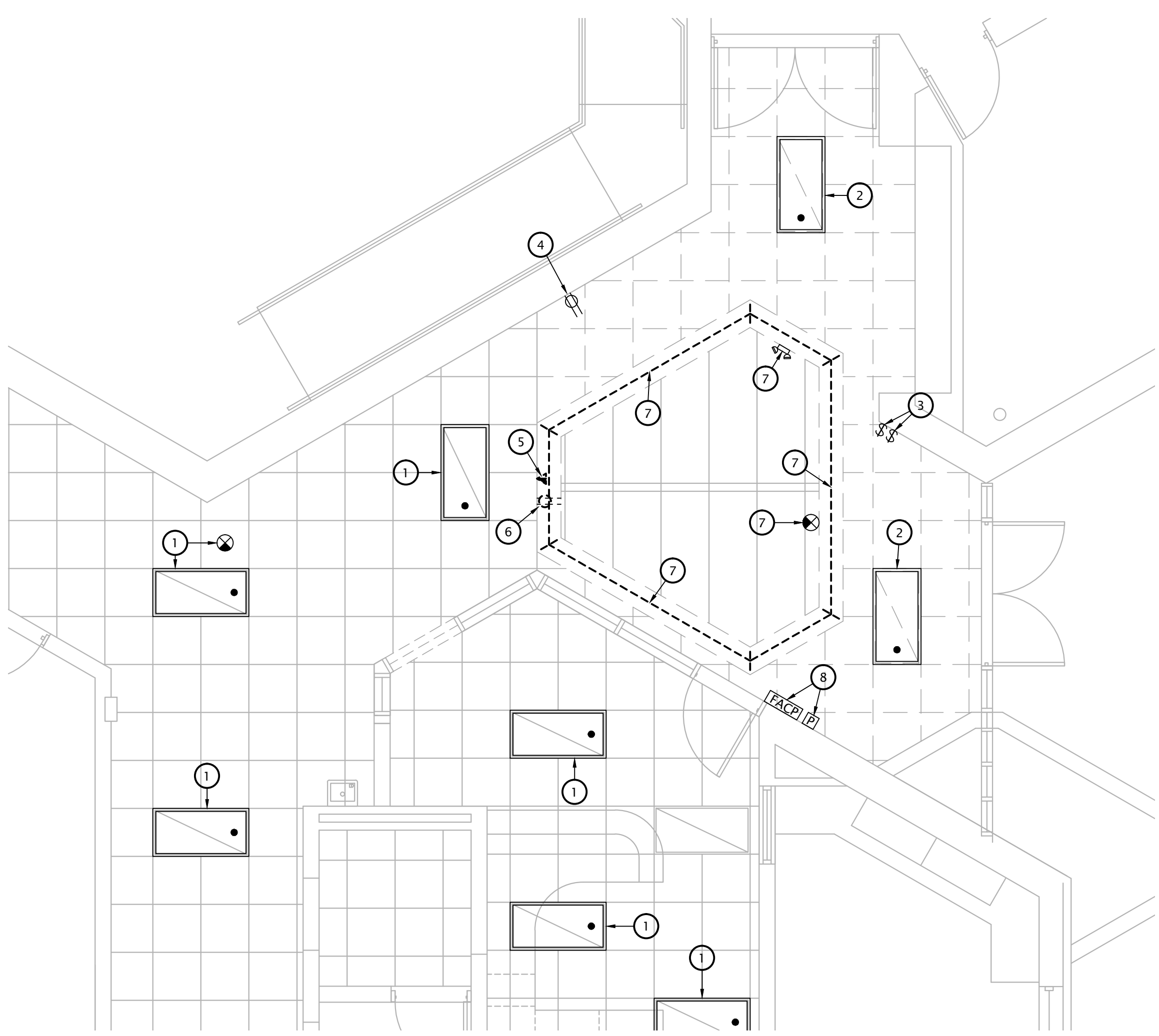

**1** ELEMENTARY SCHOOL ELECTRICAL DEMOLITION PLAN  
 1/4" = 1'-0"

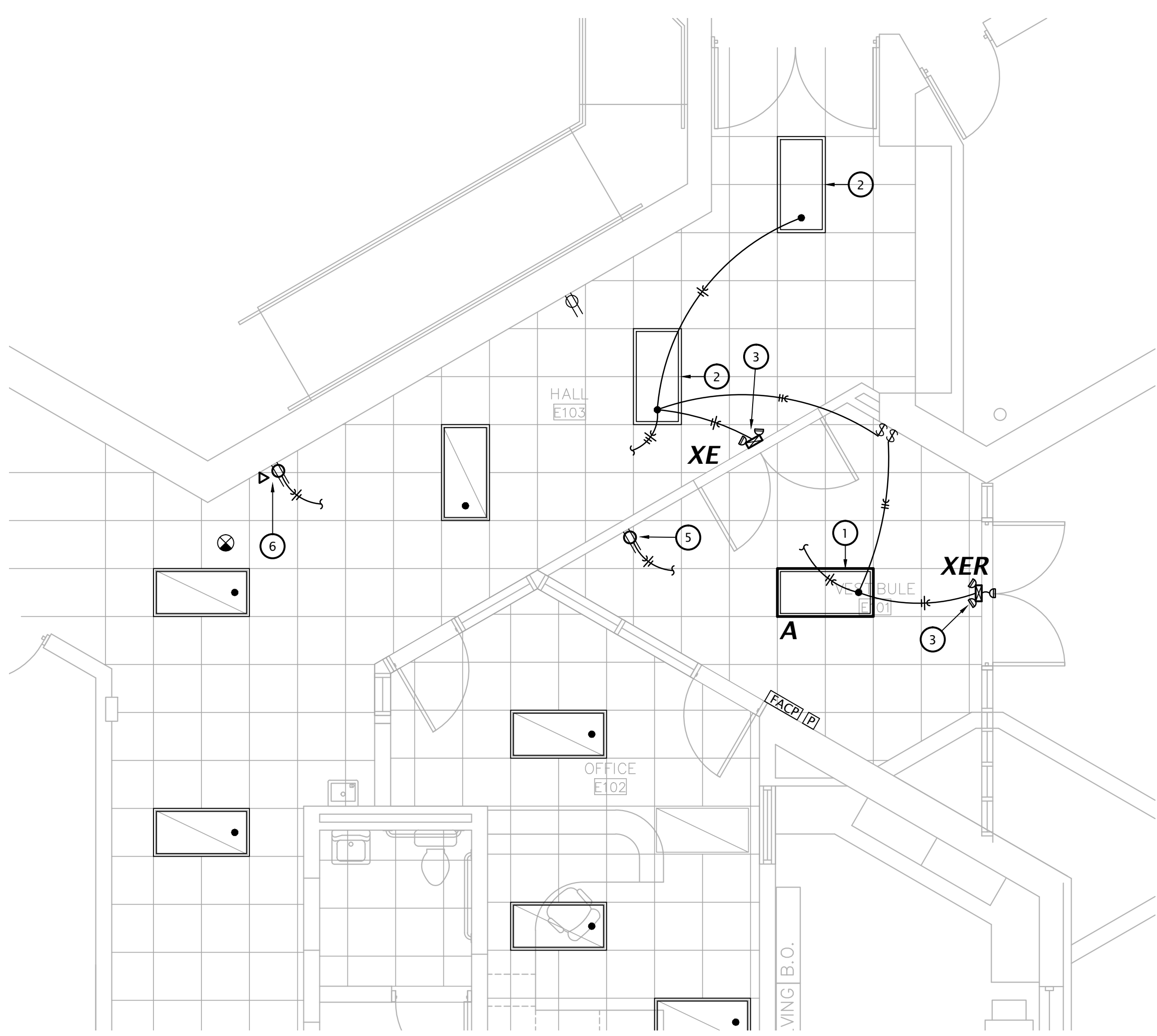

**2** ELEMENTARY SCHOOL ELECTRICAL NEW WORK PLAN  
 1/4" = 1'-0"

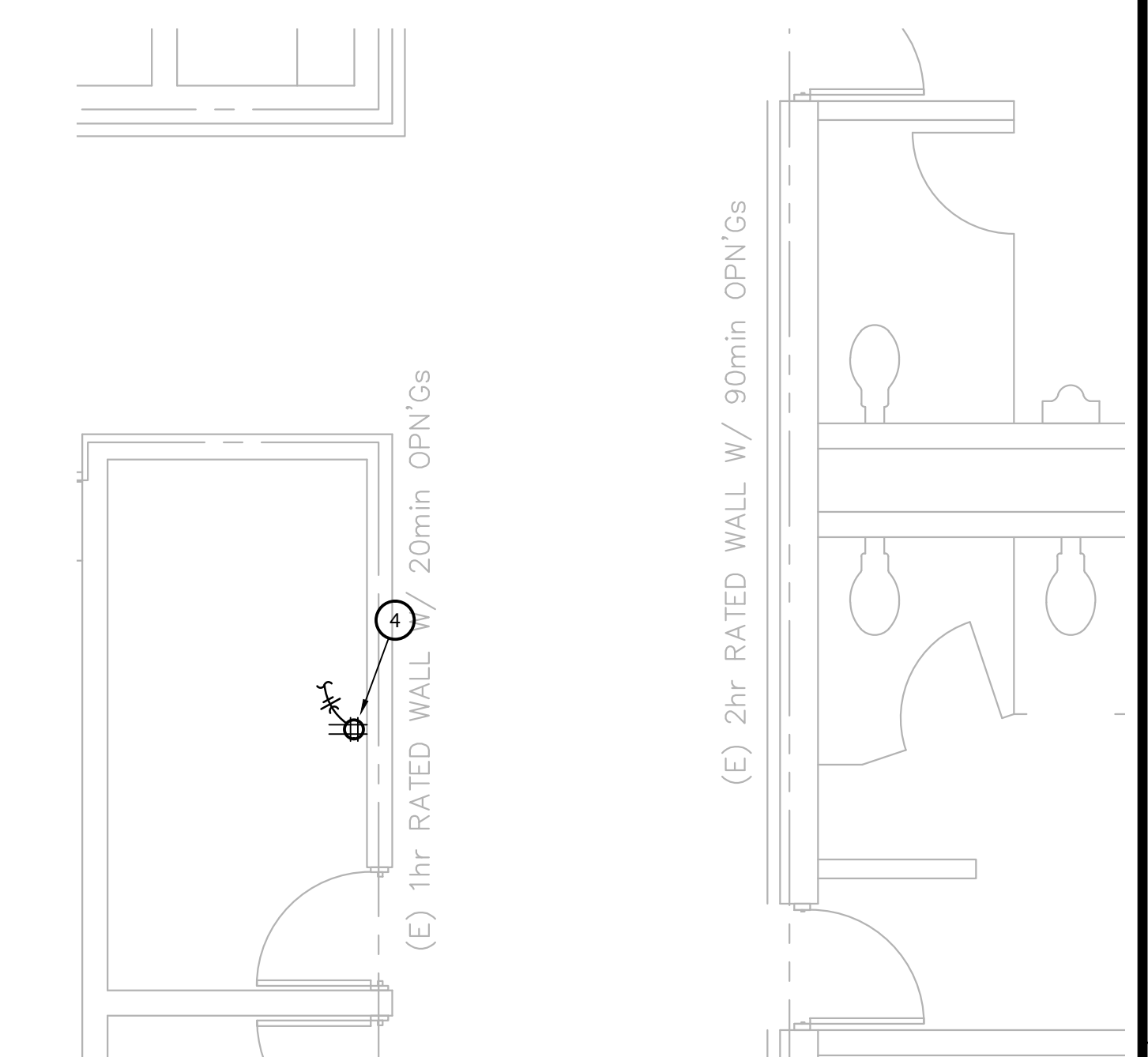

**ELEMENTARY SCHOOL ELECTRICAL  
 NEW WORK PLAN - ELECTRICAL ROOM**  
**3** 1/4" = 1'-0"

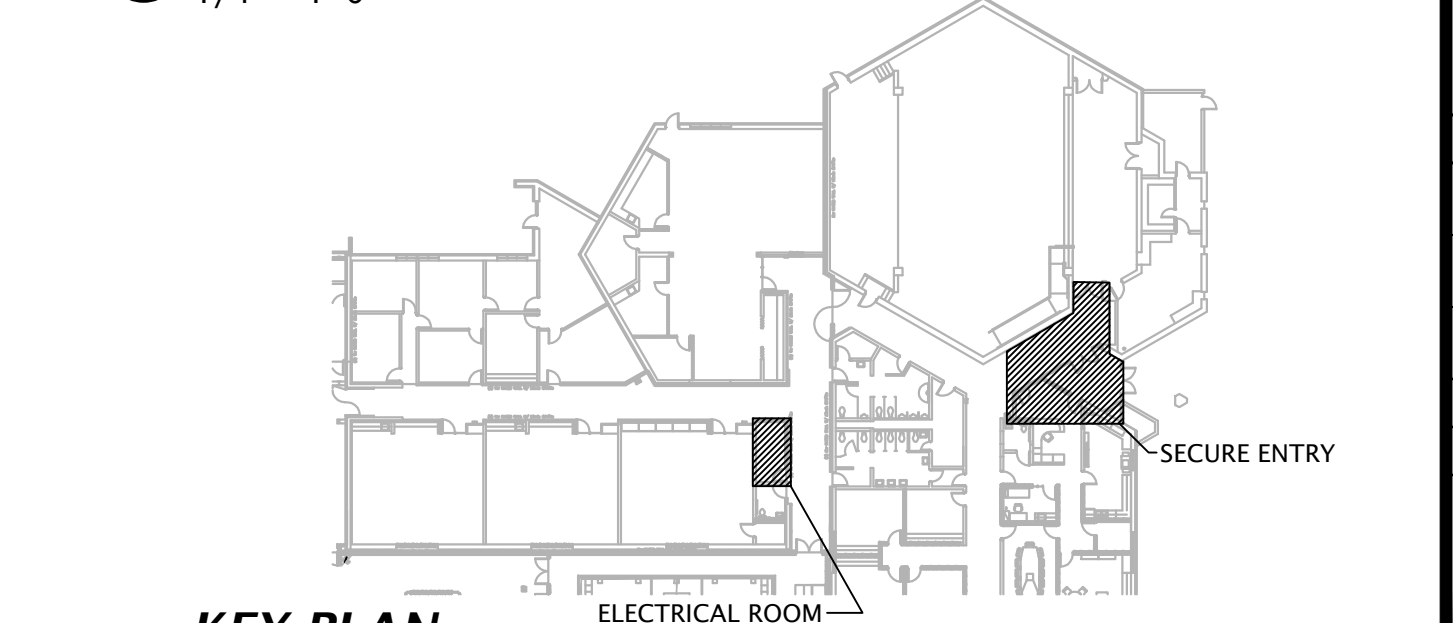

**KEY PLAN**  
 ELECTRICAL ROOM

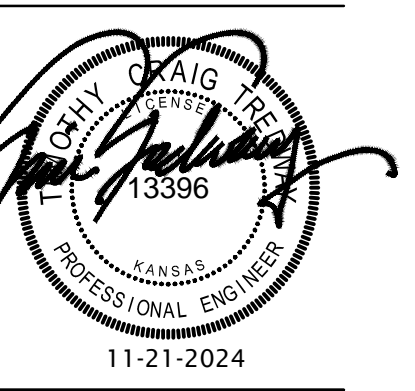

REVISION:

DATE: 11-21-2024  
 JOB: 24-3432  
 SHEET NO.: